

Use and Care Manual Gas Ranges

Familiarizing yourself with your appliance

Your appliance may vary slightly.



Range Parts Key

1	Oven Control Panel
2	Cooktop Control Knobs
3	Door Gasket
4	Door Latch
5	Probe Jack (some models)
6	Convection Fan

7	Rack Position Guides with 6 rack positions
8	Oven Bottom
9	Door Hinge
10	Warming Drawer

Range Features

Sealed Gas Burners

The cooktop has sealed gas burners. As a result, there are no parts under the cooktop to clean, disassemble or adjust. Spills stay on top of the cooktop where they are easier to wipe up.

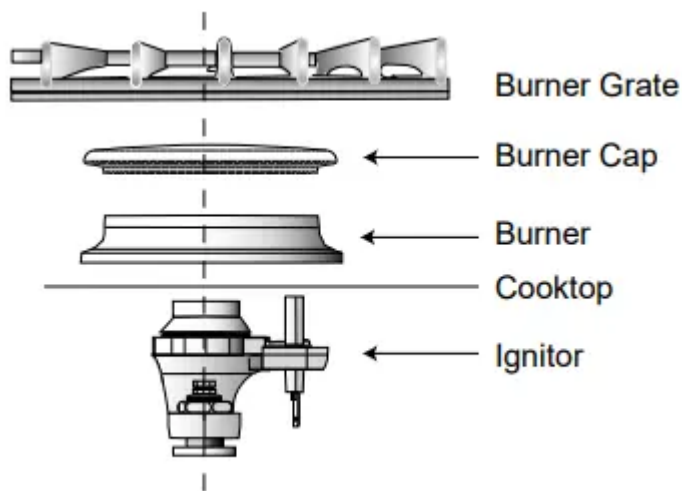

Burner Caps

The cooktop has three different burner sizes; small, medium, and large. Match the corresponding letters on the burner cap and burner base.

The burner cap is porcelainized steel. The burner caps must be properly placed for the cooktop to function properly. If the burner cap is not properly placed, one or more of the following problems may occur:

- Burner flames are too high.
- Flames shoot out of burners.
- Burners do not ignite.
- Burner flames light unevenly.
- Burner emits gas odor.

WARNING: To prevent flare-ups and avoid creation of harmful by-products, do not use the cooktop without all burner caps and all burner grates properly positioned. To prevent burns, do not touch burner caps or grates while hot. Turn the cooktop off and allow the burners to cool.

Placing Burner Caps

Each cap has a letter (A, D, or F) cast in the underside of the cap that corresponds to a letter (A, D, or F) cast in the burner base that is attached to the appliance.

Note: In some models the center burner does not have a letter designation on the burner base.

- Place each burner cap on its correct burner base per its corresponding letter designation. See figure “Placing Burner Caps” on page 7.

Place burner cap gently on top of base so that the prongs of the burner base fit snugly into the groove of the burner cap.

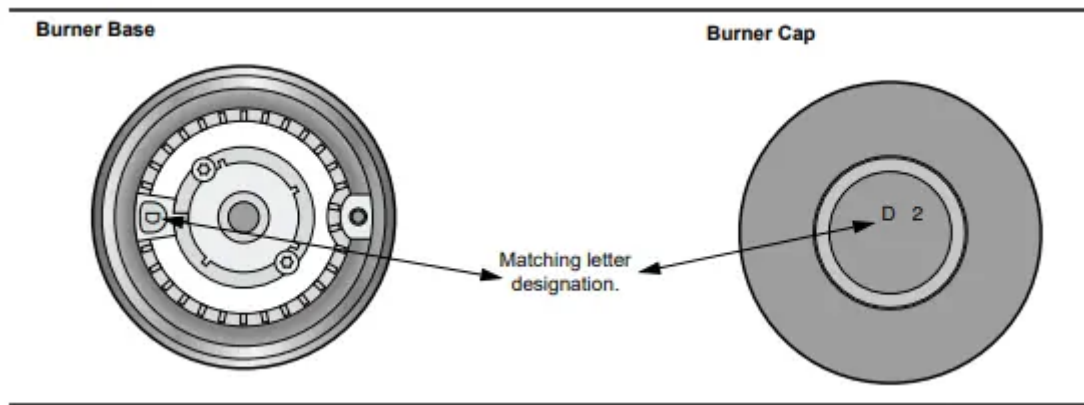

Checking Burner Cap Placement

- Check to make sure there is not a gap between the burner cap and burner base. See figure “Burner Cap Placement” on page 8 to see the correct and incorrect placements of the burner cap.
- You may gently try to move the burner cap from side to side to check if it is properly placed. If properly placed, the cap will click from side to side as the prongs hit the groove ridge.

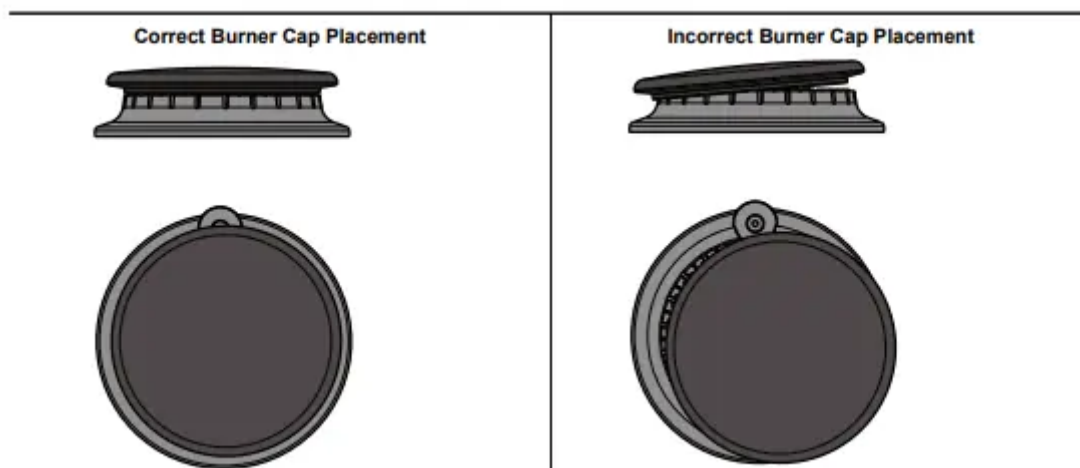
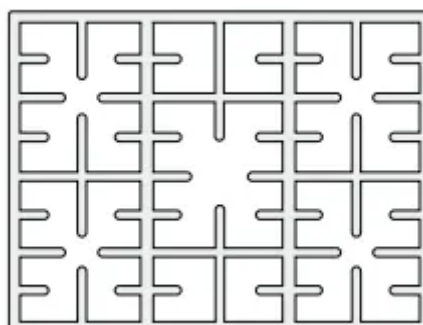

Figure 1: Burner Cap Placement

Burner Grates

Grates must be properly positioned before cooking.



WARNING To prevent flare-ups, properly support pots, and avoid spills, all grates must be properly positioned on the cooktop whenever the cooktop is in use. Do not use a grate if the rubber feet are missing or damaged.

To purchase replacement rubber feet: Part # 416438, contact your dealer or call the service number listed inside the cover.

Control Knobs

The cooktop has one control knob for each burner.

CAUTION: Failure to operate knobs properly may result in personal injury and damage to the appliance.

The cooktop has standard burner controls and rubber grommets.

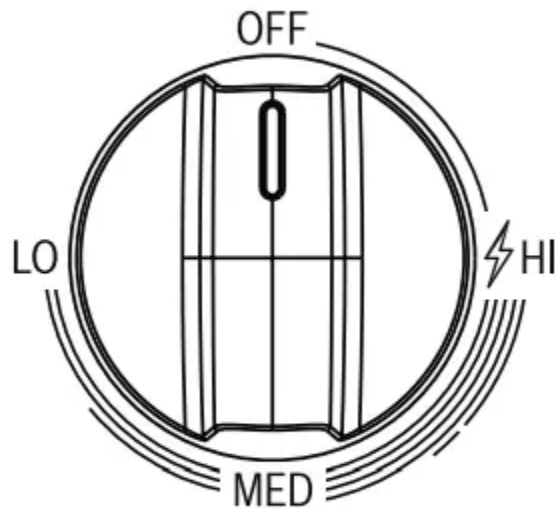

Figure 2: Standard Burner Control Knob

The standard burner controls have an infinite number of heat settings. These settings are located on the burner knob.

To operate: Select the appropriate control knob, push down and turn to the left to the ignition symbol until the burner ignites. Turn the knob to the desired setting. Turn burner off by turning the control knob clockwise to **OFF**.

Burner Control Knob Removal

To remove knob and grommet: With burner in the **OFF** position, gently lift knob up and off. Gently pull the grommet from the sides and lift out.

WARNING: To avoid possible electric shock, do not reach through control opening into rough-in box located under the cooktop.

To replace grommet and knob: Carefully insert the grommet into the opening, ensuring that the maintop is seated in the track around the entire perimeter of the grommet. Replace control knob by placing indicator line at the 12 o'clock position. Press down firmly.

Oven Features

Cooling Fan

The cooling fan runs during all cooking modes. The fan can be heard when it is running, and warm air may be felt as it is released from the oven vent. The fan may also run after the oven is off.

Convection Fan

The convection fan operates during any convection mode, but not during preheat. When the oven is operating in the convection mode, the fan will turn off automatically when the door is opened.

Oven Bottom

Note: Do not place food directly on the oven bottom.

Oven Vent

The oven vent is located at the top back of the range. Warm air may be released from the vent before, during and after cooking. It is normal to see steam escaping from the vent and condensation may collect in this area. This area may be hot when the oven is in use. Do not block the vent as it is important for air circulation.

CAUTION: Do not use aluminum foil or protective liners to line any part of an appliance, especially oven bottom. Installation of these liners may result in a risk of electric shock or fire.

Automatic Shutoff

The oven will automatically shut off after 24 hours.

Self-Cleaning

The oven features a self-cleaning function that eliminates the manual labor involved with cleaning your oven.

Indicators and Other Features

Default Settings - The cooking modes automatically select the default temperature. These can be changed when a different one is needed.

E Number Codes -These codes display when there is a problem with the range.

Stand By Mode

Stand by mode means that the oven has power, but no cooking mode or timer is running.

Accessories

Inserting Racks

CAUTION: To avoid burns, place oven racks in desired positions before turning oven on. Always use oven mitts when the oven is warm. If a rack must be moved while the oven is hot, do not let oven mitts contact hot heating elements.

Use caution when removing an oven rack from the lowest rack position to avoid contact with the hot oven door.

To avoid possible injury or damage to the appliance, ensure racks are installed exactly per installation instructions and not backwards or upside down.

Flat Rack

The rack is designed with a stop so it will stop before coming completely out of the oven and not tilt.

To insert the flat rack into the oven:

1. Grasp rack firmly on both sides.
2. Insert rack (see picture).

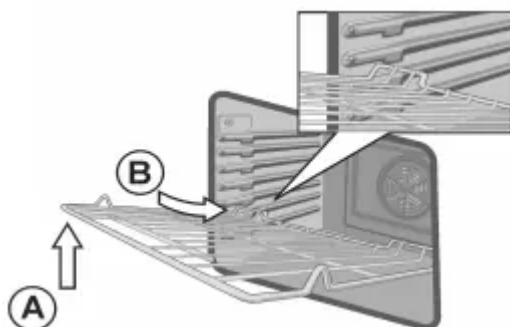

3. Tilt rack up (A) to allow the upwardly sloped rear of the rack to slide under the stop molded into the front portion of the rack guide above.
4. When the back of the rack is past this stop, lower the front of the rack to a horizontal position (B) and push it the rest of the way in. The rack should be straight and flat, not crooked.

To remove the flat rack from the oven:

1. Grasp rack firmly on both sides and pull rack toward you.
2. When the stop is reached, tilt rack up so that the upwardly sloped back of the rack can pass under the stop. Pull the rack the rest of the way out.

Telescopic Rack (some models)

To insert the telescopic rack into the oven:

1. Slide the rack in evenly until the rear of the rack is about 2 inches from the back of the oven.

2. Tilt the front of the rack up about 3/4 of an inch (A) and finish pushing the rack all the way back (B).

Note: Avoid striking the oven light cover glass when pushing the rack into position.

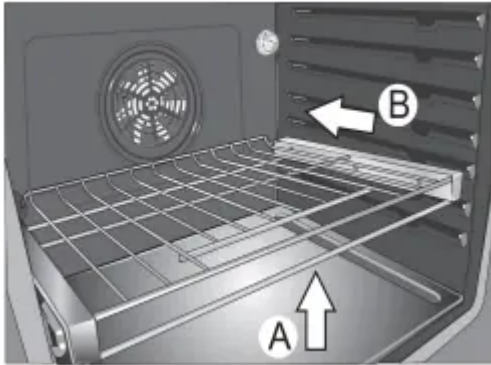

3. The back of the telescopic rack drops into place.
4. Pull the rack forward to engage the bottom of the rack onto the rear of the rack position guide.
5. Lower the front of the rack to finish seating it on the rack guide. The rack should feel stable when properly seated.
6. Slide the movable part of the telescopic rack in and out a few times to make sure it is able to move freely and that the non-moving part of the telescopic rack is securely anchored.

CAUTION: To avoid possible injury or damage to the appliance, ensure the telescopic rack is installed exactly per installation instructions and not backwards or upside down.

To remove the telescopic rack from the oven:

1. Lift the front of the telescopic rack assembly about 1/2 inch and push the rack to the rear about 3/4 inch. This allows the rack to disengage from the rack position guide.
2. Lift the rear of the telescopic rack assembly so it clears the rack position guide and gently pull the rack from the oven.

Note: Take care to avoid pulling the rack unevenly which will cause it to bind during removal, catching on the oven walls.

Before Using the Appliance for the First Time

- Remove all packing materials and labels from range. Remove packing materials from inside the oven and inside the drawer.
- While cool, wipe with a clean, damp sponge and dry.
- There may be a slight odor during first uses; this is normal and will disappear.
- Optimum cooking results depend on proper cookware and bakeware being used.

- Read and understand all safety precautions and Use and Care Manual information prior to operating.

Operation - Cooktop

This section explains how to operate the cooktop. See “Cooktop Cooking Guide” on page 22 for guidelines to improve cooktop results.

About the Cooktop

Use the cooktop for surface cooking applications such as boiling, frying, simmering, steaming and sautéing.

WARNING: To avoid risk of personal injury, while the self-clean cycle is operating, the cooktop will not operate.

When using the cooktop and the oven is set to self-clean, "Turn Off Cooktop" is shown in the display. The self-clean cycle does not come on. Turn off the cooktop to use selfclean.

The cooktop cannot be used when self-clean is running in the oven.

WARNING: To avoid risk of personal injury, while the self-clean cycle is operating, the cooktop will not operate. The burning of gas cooking fuel can create small amounts of Carbon Monoxide, Benzene and Formaldehyde. To minimize exposure to these substances, the burners should be adjusted by a certified installer or agency to ensure proper combustion. Ensure proper ventilation with an open window or use a ventilation fan or hood when cooking with Gas. Always operate the unit according to the instructions in this manual.

The cooktop has one control knob for each burner. Push down and turn to the desired heat setting.

Normal Operation (Electronic Ignition/Reignition)

The cooktop uses electronic igniters to light the burners. There is no pilot light. Each burner has its own igniter. If a burner flame blows out during use, the burner will automatically reignite.

CAUTION: To avoid possible injury or damage to the appliance, ensure grates are installed exactly per installation instructions and not backwards or upside down.

Typical Flame Characteristics

The burner flame should be blue in color and stable with no yellow tips, excessive noise or fluttering. It should burn completely around the burner cap.

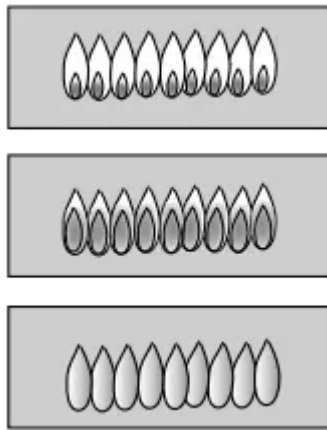

Figure 3: Checking Flame Characteristics

Yellow Flames: Further adjustment is required.

Yellow Tips on Outer Cones: Normal for LP Gas.

Soft Blue Flames: Normal for Natural Gas.

If the flame is completely or mostly yellow, verify that the regulator is set for the correct fuel. After adjustment, retest.

Some yellow streaking is normal during the initial startup. Allow unit to operate 4-5 minutes and re-evaluate before making adjustments.

Foreign particles in the gas line may cause an orange flame during initial use. This should disappear with use. Check burner to make sure port holes are not obstructed. If the ports are clogged, see “Self Help”.

NOTE: An audible “pop” may be heard when the burner is turned off manually. The “popping” may be louder with LP gas than with natural gas. This is normal.

Operation - Oven

Oven Control Panel

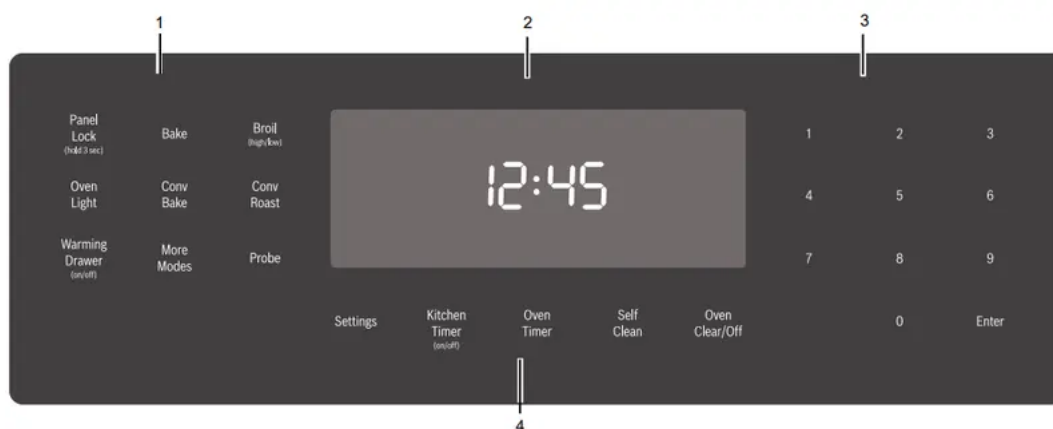

800 Series Oven Control Panel

1. Mode Selection Touchpads
2. Display
3. Numeric Keypad Touchpads
4. Special Function Touchpads

Touchpads

Note: You only need to press lightly on the touchpads to operate them.





Touchpad Descriptions

Panel Lock (hold 3 sec)	Turns Panel Lock mode on and off.
Oven Light	Turns the oven lights on or off.
Kitchen Timer (on/off)	Starts and stops the kitchen timer(s). Press to edit a timer.
Warming Drawer (on/off)	Turns the warming drawer on or off.
Oven Timer	Press to edit the oven timer for the oven. Turns off the oven at the end of the specified time.
Settings	Provides access to user settings to allow customization of basic display, language and other features. Use also to set the clock.
Probe	Sets probe target temperature. Probe allows monitoring of internal meat temperatures during cooking.
Self Clean	Activates Self Clean mode.
More Modes	Allows access to cooking/heating modes that do not have a direct access touchpad.

More Modes

Additional modes are available by pressing the **More Modes** touchpad. These modes include Warm, Pizza, Proof and Roast. These are discussed in the Getting the Most Out of Your Appliance section later in this manual.

Display Symbols

	Door Lock - Is displayed when the oven door is locked.
	Probe Symbol - Appears when a probe is detected.
	Panel Lock - Is displayed when the control panel is locked.
	Self Clean - Is displayed when Self Clean is active.

Before Using the Oven for the First Time

- Oven must be properly installed by a qualified technician before use.
- Remove all packing materials from inside and outside the oven.
- While cool, wipe with a clean, damp cloth and dry.
- There may be a slight odor during first uses; this is normal and will disappear.
- Optimum cooking results depend on proper bakeware being used.
- Read and understand all safety precautions and Use and Care Manual information prior to operating.

Operation

About the Appliance

Your new oven combines premium cooking results and simple operation.

The oven design has been optimized to improve heat distribution in the oven cavity. The result is even browning and shorter cooking times.

Thanks to the Self-Clean mode, hours of scrubbing into the darkest corners of the oven is a thing of the past. The oven burns off soil simply and easily. All that is left to do is to remove a few ashes from the oven when Self-Clean is done and the oven is cool enough to touch.

Clear labeling of the touch pads makes operating the oven very easy. This manual includes all instructions for operating the oven.

Basic Features

Setting the Clock

The oven includes time functions that require the current time to be set. It is therefore important to set the clock before beginning to use the oven. The oven cannot be operating to access the clock set mode.

To set the clock:

1. The oven must be in Stand-By mode (oven is powered on, but no cooking mode or timer in operation).
2. To access the clock set mode: Press the **Settings** touchpad. The display shows “SET CLOCK”. Press **Enter** to edit the clock.
3. Use the numeric keypad to enter the desired time. Each number pressed is entered at the right and moving previously entered digits to the left. To set “12:45 pm”, press 1, 2, 4, 5.
4. When the desired time is entered, set the time by pressing Enter. The clock is now set and running.

Setting the Cooking Mode and Temperature

There are two alternate methods to set cooking mode and temperature.

To set the Cooking Mode first, then the temperature:

1. Press the desired Cooking Mode Touchpad. The cooking mode and default temperature are displayed. The temperature flashes to show it can be edited.

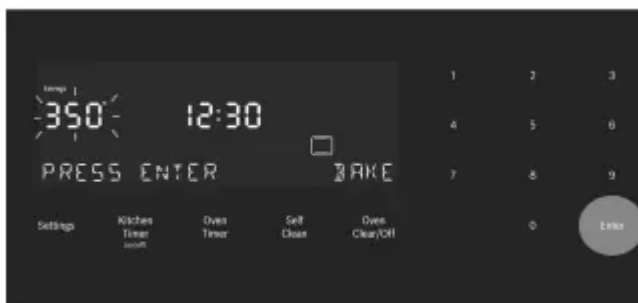

2. Press Enter to start the mode using the default temperature.
3. To change the temperature, enter the new temperature using the numeric touchpads. 375° is used for this example. Press Enter to set the updated temperature. Note: The new temperature is automatically set after 10 seconds if Enter is not pressed.
4. Preheating starts.

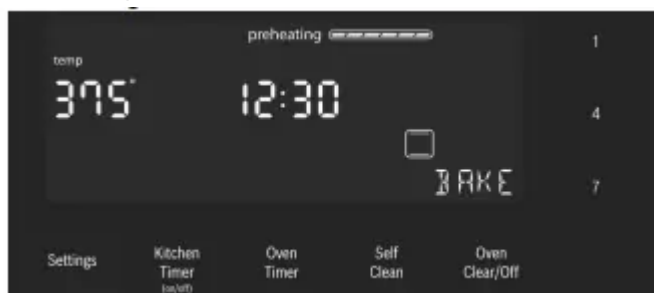

Note: If a temperature is entered that is not within the allowed range for the mode, an error tone will sound and the lower part of the screen will display “TEMP NOT ALLOWED”.

To set the Temperature first and then the Cooking Mode: (not for Broil)

1. Press the numeric keys to enter the desired temperature setting. The temperature entered is displayed beside the current time.
2. Select a cooking mode that is compatible with the temperature entered. If no cooking mode is selected within 5 seconds of setting the temperature, an error tone sounds and a SELECT MODE message is displayed and blinks.



3. Press a Mode Selection Touchpad to select a cooking mode. The new mode and temperature set automatically after 10 seconds if Enter is not pressed.

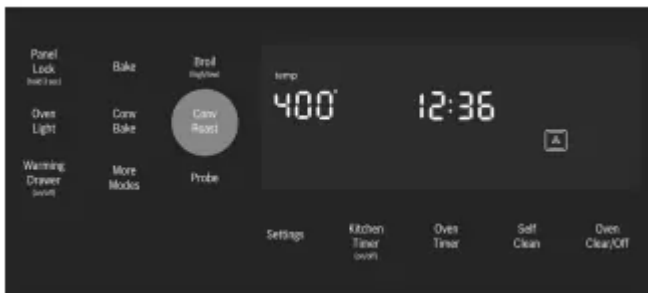

Note: If a temperature is entered that is not within the allowed range for the mode selected, an error tone will sound and the lower part of the screen will display “TEMP NOT ALLOWED”.

To change the Oven Temperature

1. Press the Cooking Mode Touchpad.
2. The current temperature flashes. Use the numeric touchpads to enter a new temperature. Press Enter.

Heating Time Limitation

The maximum heating time is limited. If you forget to turn off the oven, it turns off automatically after a set period of time.

The maximum time for Sabbath mode is 74 hours; for all other cooking modes the maximum allowed time is 24 hours.



Temperature in °F	Temperature in °C	Max. time allowed without activity
100–200	30–120	24 hours
201–550	121–300	12 hours

Timer

Your new oven is equipped with two types of timers.

Kitchen Timer - is a countdown timer that has no affect on oven heating. The kitchen timer is used for general kitchen timing needs.

Oven Timer - is a countdown timer which upon reaching 00:00 turns the oven off, stopping the current mode. The oven timer is used to set how long a mode will run (not for Broil).

To set a kitchen timer: (for general kitchen timer needs)

1. Press the **Kitchen Timer On/Off**.

0:00 is displayed and blinks in the display. Enter the desired timer value in H/MM format using the numeric keypad.

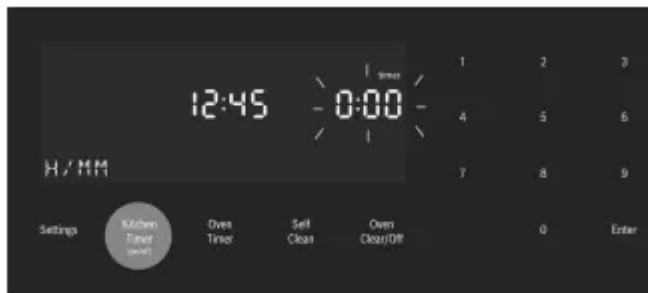

2. Press Enter.

The kitchen timer starts.

3. When the kitchen timer has counted down to zero an alarm tone sounds every 10 seconds for 2 minutes and the message "TIMER END" is displayed.

Cancel the kitchen timer - by pressing the Kitchen Timer On/Off button two times.

Note: The timer does not change when other settings are changed.

To edit a kitchen timer:

1. Press the **Kitchen Timer On/Off** button once.
2. The current time value blinks and can be edited.

To set an oven timer: (for setting a timer to turn the oven off)

Note: An oven timer cannot be run during Self Clean.

1. Press the **Oven Timer** touchpad.

2. Select mode, press Enter. 0:00 is displayed and blinks in the display. Enter the desired timer value in H/MM format using the numeric keypad.



Press the Enter touchpad. The oven timer counts down to 0:00.



3. When the timer reaches :00 the cooking mode ends and the message “OVEN TIMER FINISHED” is displayed. The oven alarm tone sounds every 10 seconds for 2 minutes.

Editing the oven timer

1. If the oven timer is running and the time remaining needs to be changed, enter the oven timer mode by pressing the Oven Timer touchpad.
2. The temperature blinks, indicating it can be edited. Input a new temperature or press Enter for no change.
3. The timer value blinks, indicating it can be edited. Input the new time and restart the timer by pressing the Enter touchpad.

The oven timer may be cleared by entering 0:00.

Special Features

The special features provide you with additional conveniences when cooking.

Learn more about these special features in the following sections:

- Probe (some models)
- Sabbath Mode
- Panel Lock

Probe (some models)

The probe measures the internal temperature of the food. The probe is available for Bake, Roast and all convection cooking modes.

Remove Safety Cap before Using Probe

Some models include a temperature probe used to sense internal temperature of meats during cooking.

The probe ships with a black plastic safety cap over the pointed metal end of the probe. The cap must be removed prior to use.



Inserting the probe:

Insert the tip of the probe in the middle and thickest part of the meat. Make sure the probe is not touching fat, bone, or parts of the oven or the pan.

Note: Food must be completely thawed before inserting the probe into the meat.

To use the probe:

1. Insert the probe into the meat as described above. The probe symbol is displayed.
2. Connect the probe to the oven. If the probe is not connected to the oven prior to starting Probe mode, an error tone sounds and the message "INSERT PROBE" is displayed.
3. Set the cooking mode and temperature.
4. The Set Probe Temp screen is displayed. A three digit input prompt "- - -" blinks in the lower right corner. Use the numeric keypad to enter the desired probe temperature and press Enter on the numeric keypad.

Note: The minimum probe temperature that can be set is 100° F (40° C) and the maximum is 200° F (100° C). If the probe temperature entered is outside this range, an

error is displayed.



5. The probe current temperature and target temperature are both displayed in the format “105 / 180” at the lower right corner of the display. The actual temperature will display < 80 until the food temperature reaches 80° F. The displayed probe temperature is updated in increments of 5° during the cooking process.



6. When the probe temperature reaches the set temperature, the cooking mode turns off. The current time is displayed and the message “COOKING COMPLETE” blinks at the bottom left of the display. An alarm tone sounds every 10 seconds for 2 minutes.



This screen remains in the display until it is cleared by pressing the **Oven Clear/Off** touchpad or until the probe is removed. The display then goes back to stand by mode.

Note:

- Probe is not available when an Oven Timer has been set.
- To change the probe temperature press the Probe touchpad. The display enters probe temperature editing mode and displays the message “SET PROBE TEMP”. Enter the new probe temperature and press Enter to accept the new value.
- Do not store the probe in the oven.
- Always use the handle of the probe for inserting and removing.
- Always use a potholder to remove the probe since it becomes hot.

- Since meat continues to cook after being removed from the oven, set the internal (probe) temperature 5 - 10 degrees below the desired final internal temperature (exception poultry).

Sabbath Mode

The Sabbath mode enables those of particular faiths to use their ovens on the Sabbath.

The Sabbath mode can be entered in a Bake mode only. The bake temperature must be within the Sabbath mode temperature range of 100° to 450° F. If the oven light is on during setup, it remains on throughout the Sabbath mode operation.

If the oven light is off during setup, it remains off throughout the Sabbath mode operation.

To set the Sabbath Mode:

No kitchen timers or oven timers may be running when Sabbath mode is entered.

1. Begin a Bake operation. While **Bake** is running, press and hold the Oven Timer touchpad for five seconds. If a timer is running when Sabbath mode attempts to start, the display blinks the message: "SABBATH NOT AVAILABLE".



If no timers are running, the Sabbath mode settings appear in the display. The Sabbath Mode timer blinks showing the value can be edited. The default value is 74:00 (the maximum number of hours for which Sabbath Mode can be set.)



2. Press **Enter** to accept the default 74:00 hours and start Sabbath Mode. Or use the numeric keypad to enter the desired Sabbath mode timer value. Timer values between 0:01 and 74:00 can be entered.

Note: If no changes are made within 10 seconds, Sabbath Mode auto starts.

3. Once Sabbath mode has begun, the display changes to show the message “SABBATH ON”.

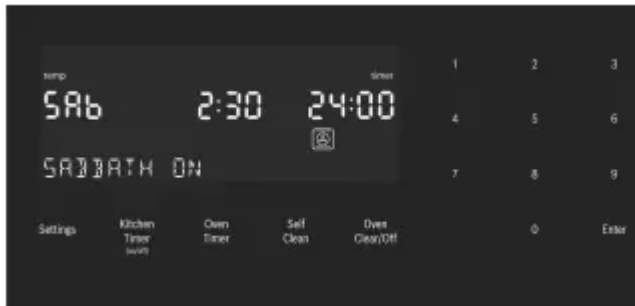

4. After the Sabbath mode countdown reaches zero, the oven displays the current time and the message “SABBATH”. No changes can be made at this point. To end the Sabbath Mode and return to normal function, press the **Oven Clear/Off** touchpad.

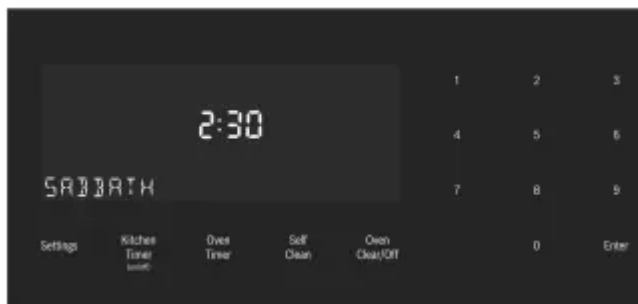

Note:

- The temperature range in Sabbath Mode is 100° F to 450° F.
- The Sabbath Mode timer can be set between 0:01 and 74 hours.

To edit the Sabbath Temperature:

While editing the temperature in Sabbath mode, there is no feedback from the control. If an invalid temperature is set, the oven will default back to the previous running temperature.

1. Press the Bake touchpad.
2. Enter the new desired set temperature.
3. Press Enter.

The oven will adjust its set temperature after a randomized delay.

Panel Lock

Allows the user to disable all buttons on the control panel. Panel Lock can only be enabled in stand by mode.

1. To enable Panel Lock, press and hold the **Panel Lock** touchpad for 3 seconds (in stand by mode).



2. To disable Panel Lock, press and hold the **Panel Lock** touchpad for 3 seconds. The display returns to stand by mode.

Settings

The oven settings menu is used to customize certain oven settings. The oven must be in Stand by mode (no cooking mode or timer running) in order to access the setup menu.

To make changes to Settings Menu Items:

1. Press the Settings touchpad.
2. The first setup item is displayed. The display shows "SET CLOCK". Press Settings again to access the settings menu.
3. To display a different setup item, press the number corresponding to that setting (see following table or press the Settings touchpad to cycle through available options).
4. To change the value for the displayed setting press the Enter touchpad to enter the edit mode. Use the numeric keypad to change the setting value. The corresponding setting value is shown in the following table.

For the temperature offset, with the item in edit mode, press "-" or "+" first, then the numeric offset value.

The new value is automatically accepted as the display reverts from edit mode back to display mode.

To exit the Settings menu:

Press the Clear On/Off touchpad.

Oven Temperature Offset

The oven is calibrated to provide accurate results. This feature is useful if you prefer your foods lighter or darker. When an offset temperature is selected, the actual oven temperature is raised or lowered by this value.

The oven must be turned off in order to set an offset value. Refer to "Temperature Offset" in "Settings Menu Options" for setting.

Settings Menu Options

Menu Item	Description	Default
1 Temperature Mode	Fahrenheit (° F) or Celsius (° C)	°F
2 Brightness	High, Medium, Low	MED
3 Volume	High, Medium, Low	High
4 Clock mode	12-hour or 24-hour display mode. 12HR, 24HR.	12HR
5 Auto Convection Conversion	Decreases oven temperature by 25 degrees set for convection cooking modes, Convection Bake. On, Off.	OFF
6 Button Beep	Tone when touchpad is pressed. On, Off.	ON
7 Stand by Clock Display	Clock displays when no cooking mode or timer is in use. ON, OFF.	ON
8 Language	Language setting: English, (EN), French, (FR)	EN
9 Temperature Offset	Sets the temperature offset value for Bake, Convection Bake, Roast, and Convection Roast. When an offset value is entered, the actual oven temperature is increased or decreased by this value. This feature is useful if food is consistently either too brown or too light. Note: Temperature offsets must always be entered as 2 digits. Example: 5° F is entered as 05. The range for changing the offset is between +/- 35° F (+/- 19° C) in 1° increments. The default value is 0.	0

Operation - Warming Drawer

About the Warming Drawer

The warming drawer will keep hot, cooked foods at serving temperature. Warming drawer settings are Low, Medium, and High.

Warming Drawer Specifications

Drawer Interior: 25" W x 17" D x 5" H

Dish sizes:

- 2 -9 x 13" Pyrex 3-quart dishes, side by side
- 2 -9 1/2 x 15" Pyrex 4-quart dishes, side by side
- 4 -10 1/2" plates, single or stacked
- 3 -11" plates, single or stacked

Operation

CAUTION - To maintain food safety, follow these guidelines:

- DO NOT use the warming drawer to heat cold food (exception: it is safe to use the drawer to crisp crackers, chips or dry cereal and to warm plates).
- Be sure to maintain proper food temperature. The USDA recommends holding hot food at 140°F or warmer.
- DO NOT warm food for longer than one hour.
- Plastic containers, plastic wrap or aluminum foil can melt if in direct contact with the drawer or a hot cooking container. If it melts onto the drawer, it may not be removable.

Preheating

For best results, preheat the warming drawer when warming food.

Preheat Times:

- Low: 10 minutes
- Medium: 15 minutes
- High: 20 minutes

Turning Warming Drawer On and Off

1. Press the Warming Drawer touchpad.
2. WARMING DRAWER will be displayed with the default setting "MED". The warming drawer amber icon is displayed below the clock.
3. To accept the "MED" setting, press the "Enter" touchpad on the numeric keypad. The setting is accepted and the warming drawer icon remains illuminated. If enter is not pressed, the warming drawer setting is not accepted and the warming drawer turns off.
4. To change the setting, when "MED" is displayed, press the warming drawer touchpad again. The setting changes to "HIGH". Press the warming drawer touchpad again to change the setting to "LOW". To accept a setting, press the Enter key on the numeric keypad. The displayed setting will be accepted and the warming drawer icon is illuminated below the clock, indicating that the warming drawer is active.
5. To turn the warming drawer off, press the warming drawer touchpad and the warming drawer will turn off and the warming drawer icon will no longer appear under the clock.

Warming Empty Serving Bowls and Plates

- Use only heat-safe dishes.
- Warm on setting appropriate for cooking container.
- Check dish temperature during warming period.
- Place empty plates or dishes in a cold warming drawer. Do not preheat drawer prior to placing dishes.

Getting the Most Out of Your Cooktop

Cooktop Cooking Guide

Boiling Water

Time to boil can vary greatly depending on environmental conditions. Try the following tips to decrease boil time:

- Use a lid.
- Use a pan that is appropriately sized for the amount of water and the size of the element.
 - Select a pan with a flat base (See “Cookware Selection Guide” in the next column for details).
- Choose a medium-weight pan (rather than a heavyweight one).
- Make sure that the pan is positioned so that the entire base is in contact with the burner grate.
- Start with water that is already warm.
- Boil the smallest amount of water necessary. Smaller volumes will boil faster than larger volumes.

Recommended Settings

Use this chart as a guide for heat settings. A range of heat settings are listed because the actual setting depends on:

- type and quality of pan (See “Cookware Selection Guide”),
- type, quantity and temperature of the food,
- element used and
- the cook’s preference.

Uses	Heat Setting
Bringing water to a boil	High
Pan frying, sauteing, browning meat, deep fat frying	Medium High
Most frying, eggs, pancakes, slow boil	Medium
Finish cooking covered foods, steaming	Medium Low
Melting chocolate and butter, simmering tomato sauces, soups, stews	Low



Cookware Selection Guide

Cookware Characteristics

- Aluminum or copper bottomed pans conduct heat evenly.
- Steel pans, if not combined with other metals, may cook unevenly.
- Cast-iron cookware absorbs heat slowly and cooks more evenly at low-to-medium settings.
- Flat, heavy bottom pans provide even heat and stability.
- DO NOT USE pans that are thin, warped, dented or ridged as they heat unevenly.

Tight Fitting Lids – A lid shortens cooking/boiling time by holding heat inside the pot.

Cookware Tips

- Use of pots and pans with rounded (either concave or convex) warped or dented bottoms should be avoided.
- Make sure the bottom of the pot or pan being used is clean and dry.
- Use pots and pans with thick, smooth metal bottoms.

Specialty Pans

Pan Bottom Diameter

- The flame should be the same size as the bottom of the pan or smaller. Do not use small pans with high flame settings as the flames can lick up the sides of the pan.
- Oversize pans that span two burners are placed front to back, not side to side.
- For best cooking results, large pans should not extend over the sides of the grates.



Use Balanced Pans

- Balance is important for stability and even cooking.
- Pans must sit level on the cooktop grate without rocking or wobbling.
- Center pan over burner.



Use a Lid That Fits Properly

A well-fitting lid helps shorten the cooking time.



Getting the Most Out of Your Oven

General Tips

Pan Placement

Baking results are better if pans are placed in the center of the oven. If baking more than one pan on a rack, allow at least 1" to 1 ½" of air space around the pan. When baking four cake layers at the same time, stagger pans on two racks so that one pan is not directly above the other.

Rack Position

Rack positions are numbered from 1 to 6, from bottom to top. Consult the food cooking charts at the back of this manual for recommended rack positions.

The rail at the top of the oven is used as the guide for the top rack (position 6). Use rack positions 1 through 6 only. DO NOT attempt to use the top guide to support an oven rack.



Rack Position & Best For

- 6: (highest position)
- 5: hamburgers, steaks, melting cheese, browning toppings, broiling most meats and fish
- 4: broiling poultry and thicker meats, toasting bread
- 3: most baked goods on a cookie sheet or baking pan using a single rack, includes frozen convenience foods, cakes, casseroles, frozen pizza
- 2: small roasts or poultry, bundt cakes, pies, breads
- 1 (lowest position): large roasts, turkey, angel food cake.

Aluminum Foil

Do not use aluminum foil or protective liners to line any part of the appliance, especially the oven bottom. Installing these liners may result in risk of electric shock or fire.

Preheating the Oven

- Place oven racks in desired position before heating the oven.
- Preheat the oven when using the Bake, Convection Bake, Pizza, Broil, and Warm modes.
- Preheat is not used for Roast, Convection Roast and Proof modes.
- Allow oven to preheat while preparing recipe ingredients or food items.
- Setting a higher temperature does not shorten preheat time.
- Once oven is preheated, place food in the oven as quickly as possible to minimize the loss of heat and reduction of oven temperature.

Preheat Reminders

- Preheating is not necessary for meats, poultry, casseroles and some frozen foods.
- Increasing the oven temperature will require a longer preheat time. For example, the preheat time for 425° F is longer than the preheat time for 350° F.

When broiling, preheat the oven 3-4 minutes. Do not preheat for more than 5 minutes.

For Best Results

- Use the cooking recommendations as a guide.
- Open the door as briefly as possible to avoid temperature reduction.
- Use the interior oven light to view the food through the oven window rather than opening the door frequently.
- Use the Kitchen Timer to keep track of cooking times.

Baking Pans and Dishes

- Glass baking dishes absorb heat. Reduce oven temperature 25° F when baking using glass dishes.
- Preheat the oven before adding glass baking dishes.
- Use pans that provide the desired browning. For tender, light, golden-brown crusts, use light, anodized or shiny metal bakeware.
- Dark, rough or dull pans (nonstick or anodized) will absorb heat and result in a browner, crisper crust. Some manufacturers recommend reducing the temperature 25 °F when using this type of pan. Follow manufacturers' recommendations.
- Insulated cookie sheets or bakeware will increase the length of cooking time.
- Do not set any heavy object on the open oven door.
- Do not keep empty pans or pizza stones in the oven during cooking as this could change the cooking performance. Store pans outside the oven.

Opening the Oven Door

- Open and close the appliance door only by holding the door handle. To avoid risk of burns, do not touch any other parts of the door.

High Altitude Baking

- When cooking at high altitudes, recipes and cooking times will vary.
- It is normal for a certain amount of moisture to evaporate from the food during any cooking process. The amount depends on the moisture content of the food. The moisture may condense on any surface cooler than the inside of the oven, such as the control panel.

Temperature Range by Cooking Mode

Temperatures shown are in Fahrenheit.

Mode	Lowest	Highest
Bake	100	550
Roast	100	550
Broil (Low, High)	450	550
Warm	150	225
Proof	85	125
Convection Bake	100	550
Convection Roast	100	550
Pizza	100	550

Cooking Modes

Bake

Bake is cooking with dry heated air. Heat comes from the lower burner and cycles to maintain the oven temperature. The Bake mode can be used to prepare a variety of food items, from pastries to casseroles. Refer to recipe or package directions for oven temperature and baking time.

Tips

- When using the Bake mode, preheat the oven if the recipe recommends it.
- Baking time will vary with the size, shape and finish of the bakeware. Dark metal pans or nonstick coatings will cook faster with darker results. Insulated bakeware will lengthen the cook time for most foods.
- For best results, bake food on a single rack with at least 1 1/2" space between pans or dishes and oven walls.

- Eliminate heat loss from the oven by using the window to periodically check food for doneness instead of opening the door.
- If multiple racks are used, use a maximum of 2 racks. For cookies and cakes use positions 2 and 5. Stagger pans so that one is not directly above the other

Convection Bake

Convection Bake is similar to Bake. Heat comes from the lower burner that is circulated throughout the oven by the convection fan. The Convection Bake mode is well suited for cakes, bar cookies and breads to take advantage of the bottom heat, yielding a better crust on baked items. It is also best for baking cookies, biscuits, cream puffs, on multiple racks (2 or 3) at the same time. The benefits of Convection Bake include: -- Slight decrease in cook time. -- Higher volume (yeast items rise higher).

Tips

- Place food in shallow, uncovered pans such as cookie sheet without sides.
- For cakes and cookies use rack positions 3 and 5.
- If baking more than one pan on a rack, allow at least 1" to 1 1/2" of air space around the pan. Stagger pans so that one is not directly above the other (see graphic).

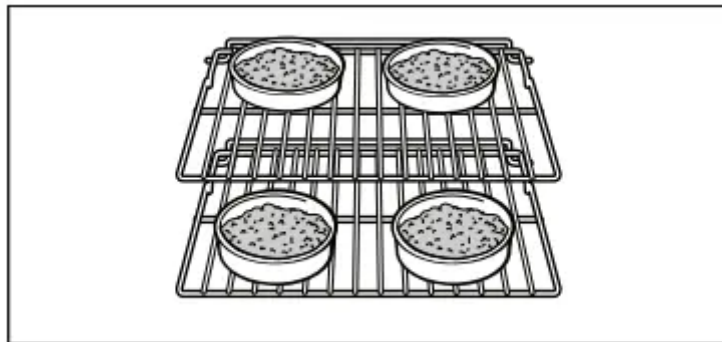

Auto Convection Conversion

The Convection Bake mode requires a 25° F reduction in temperature. Auto Convection Conversion reduces the temperature you enter automatically. Simply enter the package or recipe temperature when setting the mode. The control calculates the correct temperature and it is shown in the display.

The Auto Convection Conversion feature can be turned on to allow for automatic temperature adjustments.

Pizza In the Pizza mode, heat from the lower burner is circulated throughout the oven by the convection fan. Use the Pizza mode for fresh or frozen pizza.

Tips

- When baking a frozen pizza: For a crispy crust, place pizza directly on the rack. For a softer crust, use a pizza pan.
- When proofing pizza dough, coat dough with olive oil and cover it in a bowl tightly with plastic wrap to prevent crust formation.
- Sprinkle cornmeal on the pizza pan to prevent sticking.
- If using a pizza paddle, sprinkle the paddle liberally with cornmeal for ease in transferring the dough to the pan.
- If par baking handmade pizza dough, prick the dough with a fork before baking.
- If using a pizza pan, choose a dark, perforated pan for a more crisp crust and a non-perforated pan for a softer crust.
- Preheat baking stones following manufacturer's recommendations while the oven is preheating.
- Bake homemade pizzas on rack position 2 in the center of the rack.
- Follow manufacturer's directions for frozen pizza.

Roast

Roast uses the lower burner to maintain the oven temperature. Roast is best suited for meat and poultry and less tender cuts of meat.

Tips:

- Preheating the oven is not necessary.
- Use a high-sided broil pan or roasting pan. Cover dish with a lid or foil for less tender cuts of meat.
- For less tender cuts of meat, add liquids such as water, juice, wine, bouillon or stock for flavor and moisture.
- Roasting bags and using a lid are suitable for use in this mode.
- When roasting whole chicken or turkey, tuck wings behind back and loosely tie legs with kitchen string.

Convection Roast

Convection Roast uses heat from the lower burner as well as heat circulated by the convection fan. The Convection Roast mode is well suited for preparing tender cuts of meat and poultry. It is also suitable for roasting vegetables.

The benefits of Convection Roast include:

- As much as 25% faster cooking than non-convection modes.
- Rich, golden browning.

Tips:

- Preheating the oven is not necessary.
- Use the same temperature as indicated in the recipe.
- Check doneness early, since roasting time may decrease. Refer to the Meat/Poultry cooking chart for examples.
- Do not cover meat or use cooking bags.
- Use a broil pan with a rack and grid or a shallow, uncovered pan with a rack for roasting.
- Use a meat thermometer to determine the internal temperature of the meat.
- If the meat is browned to your liking, but is not yet done, a small strip of foil can be placed over the meat to prevent overbrowning.
- Let meat stand covered with foil for 10 to 15 minutes after removing it from the oven.
- Refer to the Meat/Poultry Cooking Chart for recommended rack positions.

Broil

Broil uses intense heat radiated from the upper burner. The Broil mode is best suited for cooking thin, tender cuts of meat (1" or less), poultry and fish. It can also be used to brown breads and casseroles. Always broil with the door closed. The benefits of broiling include:

- Fast and efficient cooking.
- Cooking without the addition of fats or liquids.

Tips:

- Preheat oven 3–4 minutes. Do not preheat for more than 5 minutes.
- Steaks and chops should be at least $\frac{3}{4}$ " thick.
- Brush fish and poultry with butter or oil to prevent sticking.
- Use a broil pan and grid, or a deep pan with a metal rack, for broiling.
- Do not cover the broil grid with foil. It is designed to drain fats and oils away from the cooking surface to prevent smoking and spattering.
- Turn meats (other than fish) once during the recommended cook time. Fish does not need to be turned.
- When top browning casseroles, use only metal or glass ceramic dishes such as CorningWare .
- Never use heat-proof glass (Pyrex); it cannot tolerate the high temperature.
- For broil times, refer to the Meat/Poultry Cooking Chart.

Proof

Proof is using the lower burner to maintain a low temperature to proof bread, pizza dough or other yeast doughs.

- No preheat is necessary.
- Proofing is the rising of yeast dough.
- The Proof Dough mode temperature range is 85° F to 125° F.
- The default temperature in the Proof Dough mode is 100° F.
- Loosely cover the bowl or pan and use any rack that accommodates the size of the container.
- Keep the oven door closed and use the oven light to check the rising of the dough.

Warm

Warm is cooking with dry, heated air. The lower burner cycles to maintain the oven temperature.

- Use the Warm mode to keep cooked foods hot until ready to serve for up to one hour.
- Warm mode temperatures are 150° F to 225° F.
- The default temperature in the Warm mode is 170° F.
- Foods that must be kept moist should be covered with a lid or aluminum foil.

Getting the Most Out of Your Warming Drawer

General Tips

Refer to the Warming Drawer Chart for recommended settings.

- To keep several different foods hot, set the temperature for the food needing the highest setting.
- Place items needing the highest setting toward the side of the drawer and items needing less heat in the center of the drawer.
- Food should be at serving temperature (above 140° F) before being placed in the warming drawer.
- Preheat empty serving dish while preheating drawer if desired.
- Place cooked, hot food in warming drawer in its original cooking container or in a heat-safe serving dish.
- Aluminum foil may be used to cover food; However, DO NOT line the warming drawer with aluminum foil.
- Do not use the warming drawer for storage.

Preheating the Warming Drawer

Preheat the warming drawer when warming food. For best results, preheat for the following times:

Setting & Preheat Time

- LOW: 10 minutes
- MED: 15 minutes
- HIGH: 20 minutes

Warming Food

1. Preheat warming drawer.
2. Place cooked, hot food in the drawer. It is okay to leave food in the cookware it was prepared. Alternatively, you can transfer food to a heat-safe serving dish before placing it in the warming drawer. Aluminum foil or lid may be used to cover food.

Warming Plates and Bowls

Use only heat-safe dishes. Place empty dishes or plates in a cold warming drawer. No need to preheat.

Select **LOW**.

Crisping Stale Items

Place food in low sided dishes or pans.

1. Press LOW.
2. Preheat for 5 minutes, then place dish in drawer.
3. Set the warming timer.
4. Check crispness after 45 minutes. Add time as needed.

Food/Cookware	Setting	Cover Dish
Bacon	HIGH	No
Beef, medium and well done	MED	No
Beef, medium rare	LOW	No
Bread, hard rolls	MED	No
Bread, soft rolls, coffe cakes	MED	Yes
Biscuits	MED	Yes
Casseroles	MED	Yes
Eggs	MED	Yes
Fish, seafood	MED	Yes
Fried foods	HIGH	No
Gravy, cream sauces	MED	Yes
Ham	MED	Yes
Pancakes	HIGH	Yes
Pies, one crust	MED	Yes
Pies, two crusts	MED	No
Pizza	HIGH	No
Pork	MED	Yes
Potatoes, baked	HIGH	Yes
Potatoes, mashed	MED	Yes
Poultry, roasted	MED	Yes
Vegetables	MED	Yes
Plates	LOW	No
Plate of food	MED	Yes

Cleaning and Maintenance

Cooktop

Daily Cleaning

The entire Cooktop can be safely cleaned by wiping with a soapy sponge, then rinsing and drying. If stubborn soil remains, follow the recommended cleaning methods below.

- Always use the mildest cleaner that will do the job. Use clean, soft cloths, sponges or paper towels.
- Rub stainless steel finishes in the direction of the grain. Wipe area dry to avoid water marks.
- Before cleaning, be certain the burners are turned off and the grates and burners are cool.
- Do not clean removable cooktop parts in any selfcleaning oven.
- After cleaning, place all parts in their proper positions before using cooktop.
- For proper burner performance, keep igniters clean and dry.
- Keep the ignitor ports clean for proper lighting performance of the burners. It is necessary to clean these when there is a boilover or when the burner does not light even though the electronic igniters click.
- Do not use flammable cleansers such as lighter fluid or WD-40.

CAUTION: All igniters spark when any single burner is turned on. Do not touch any of the burners when the cooktop is in use.

Cleaning Guidelines

The cleaners recommended below and on the following page indicate a type and do not constitute an endorsement of a particular brand. Use all products according to package directions.

Cooktop Part / Material	Suggested Cleaners	Important Reminders
Burner Base Aluminum Alloy	<ul style="list-style-type: none"> • Detergent and hot water; rinse and dry. • Stiff nylon bristle toothbrush to clean port openings. • Abrasive Cleaners: Brillo or S.O.S. pads. Rinse and dry. 	<ul style="list-style-type: none"> • Do not scratch or gouge the port openings. • Clean ports with a wire or straightened paper clip. • Do not use a toothpick that may break off.
Burner Cap Porcelain Enamel	<ul style="list-style-type: none"> • Hot sudsy water; rinse and dry thoroughly. • Nonabrasive Cleaners: Fantastic®, Formula 409®. • Mild Abrasive Cleaners: Bon Ami®, Ajax®, Comet®. • Liquid cleaners: Kleen King®, Soft Scrub®. • For food stains, use an abrasive cleanser such as, Zud® or Bar Keepers Friend®. • Reassemble. Make sure that the cap is seated on the base. 	<ul style="list-style-type: none"> • Acidic and sugar-laden spills deteriorate the porcelain enamel. Remove soil immediately. • Do not use wet sponge or towel on hot porcelain. • Do not soak burner caps. • Always apply minimal pressure with abrasive cleaners. • Dry thoroughly after cleaning.
Exterior Finish Stainless Steel	<ul style="list-style-type: none"> • Nonabrasive Cleaners: Hot water and detergent, Fantastic®, Formula 409®. Rinse and dry immediately. • Cleaner Polish: Stainless Steel Magic® to protect the finish from staining and pitting; enhances appearance. 	<ul style="list-style-type: none"> • Do not use steel wool pads. They will scratch the surface. • Stainless steel resists most food stains and pit marks providing the surface is kept clean and protected. • Never allow food stains or salt to remain on stainless steel for any length of time.



	<ul style="list-style-type: none"> • Hard water spots: Household white vinegar. • Mild Abrasive Cleaners: Kleen King Stainless Steel liquid cleaner, Bon Ami®. • Heat discoloration: Bar Keepers Friend® 	<ul style="list-style-type: none"> • Rub lightly in the direction of the grain. • Chlorine or chlorine compounds in some cleaners are corrosive to stainless steel. Check ingredients on label before using. Grates Porcelain Enamel on Cast Iron • Nonabrasive cleaners: Hot water and detergent, Fantastic®, Formula 409®. Rinse and dry immediately. • Mild abrasive cleaners: Bon Ami® and Soft Scrub®. • Abrasive cleaners for stubborn stains: soap-filled steel wool pad. • The grates are heavy;
<p>Grates Porcelain Enamel on Cast Iron</p>	<ul style="list-style-type: none"> • Nonabrasive cleaners: Hot water and detergent, Fantastic®, Formula 409®. Rinse and dry immediately. • Mild abrasive cleaners: Bon Ami® and Soft Scrub®. • Abrasive cleaners for stubborn stains: soap-filled steel wool pad. 	<ul style="list-style-type: none"> • The grates are heavy; use care when lifting. Place on a protected surface for cleaning. • Blisters/ crazing/ chips are common due to the extreme temperatures on grate fingers and rapid temperature changes. • Acidic and sugar-laden spills deteriorate the enamel. Remove soil immediately. • Abrasive cleaners, used too vigorously or too often, can eventually mar the enamel. • Do not clean in a self-clean oven.
<p>Igniters Ceramic</p>	<ul style="list-style-type: none"> • Carefully wipe with a cotton swab dampened with water, ammonia or Formula 409®. • Gently scrape soil off with a toothpick 	<ul style="list-style-type: none"> • Avoid excess water on the igniter. A damp igniter will prevent burner from lighting. • Remove any lint that may remain after cleaning.



Cleaning the Oven

WARNING: Children should not be left alone or unattended in an area where appliances are in use. During the self clean cycle, parts of the appliance may become potentially harmful to persons who lack adult knowledge of appliances and adult reactions to potentially harmful conditions. During the elimination of soil during self-cleaning, small amounts of carbon monoxide can be created. Fiberglass insulation could give off very small amounts of formaldehyde during the first several cleaning cycles. To minimize exposure to these substances, provide good ventilation with an open window, or use a ventilation fan or hood.

Self Clean

During self-clean, the oven is heated to a very high temperature. Soil is burned off at this temperature.

NOTICE: Wipe out excessive spillage before self-cleaning the oven. Do not clean parts or accessories in the self-clean oven. Remove all baking dishes and oven racks from the oven prior to running self-clean.

To set the self-clean mode:

1. Remove all accessories and racks from the oven.
2. If there is a cooking mode on, press **Oven Clear/Off** to end the running mode. If self-clean is set and the cooktop is turned on, the burner will light and "TURN OFF COOKTOP" flashes in the display. After a short time, "SELF CLEAN FINISHED" is displayed and the cooktop continues to operate.
3. Press the Self Clean touchpad below the display. The self-clean icon  appears in the display. The selfclean timer default (4:00) hours blinks to indicate it can be accepted or changed.
To accept the 4:00 hour default self-clean time, press **Enter** on the numeric keypad.
To enter a different number of hours use the numeric keypad. The value entered must be within the range of 2:00 to 4:00 hours. Entering a value less than 2:00 or greater than 4:00 results in an error tone and message.

Use a longer setting for a heavily soiled oven.



4. When the desired self-clean time is displayed, press **Enter** on the numeric keypad.
The oven door locks prior to starting Self Clean.

The door lock symbol L is displayed and blinks while the door is being locked. Once locked, the door lock symbol is continuously illuminated (not blinking).

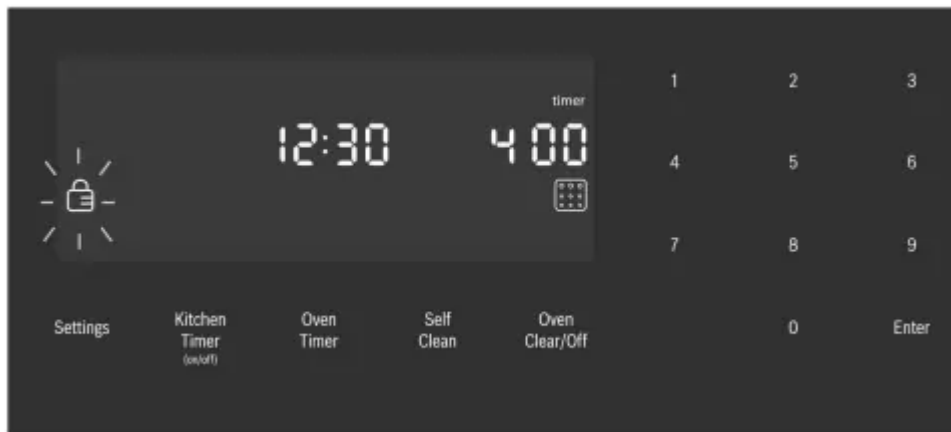

The door lock symbol remains illuminated as long as the self-clean mode is running.

Note: The door remains locked until the oven has cooled down after self-cleaning. The door can be opened again only after “**Self Clean**” disappears from the display.

5. **Self Clean** starts and the oven self-clean timer begins its countdown.

To cancel Self Clean

Press the Oven Clear/Off touchpad to cancel self clean.

When the self-clean timer ends, for safety the unit must cool down before the door can

unlock. During this period the message “COOLING DOWN” is displayed.

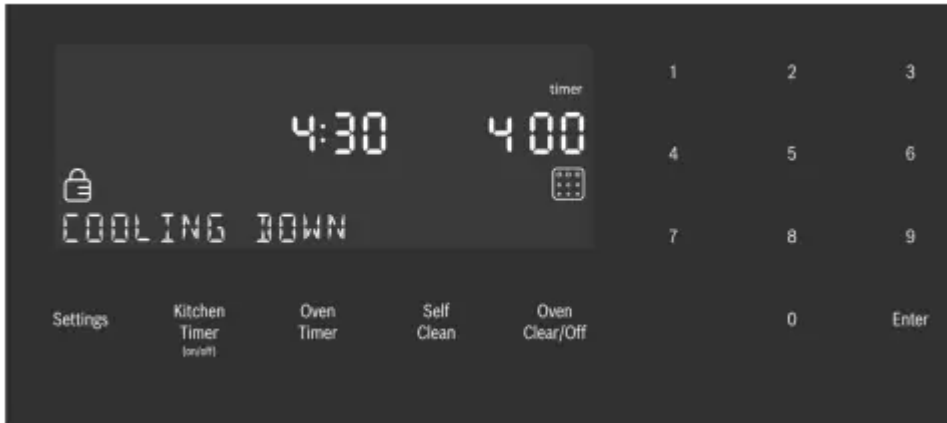

6. When the cool down is complete, the message “SELF CLEAN FINISHED” is displayed. Continue to use caution when opening the oven door.



7. Press Oven Clear/Off to clear the display when self-clean is finished.
8. After the oven has cooled down and the door is unlocked, wipe remaining ash from the oven using a moist cloth.

Note:

- The oven light cannot be turned on during self cleaning.
- The special heat-resistant enamel and the polished components in the oven can become discolored over time. This is normal and does not affect operation. Do not use scouring pads or abrasive cleaners to treat discolorations.

Avoid These Cleaners

Do not use commercial oven cleaners such as Easy Off. They may damage the oven finish or parts.

Chlorine or chlorine compounds in some cleansers are corrosive to stainless steel.

Check ingredients on label. Never use scouring pads or abrasive cleaners.



Oven Cleaning Guide



Part Recommendations	Part Recommendations
Flat Rack	<p>Wash with hot soapy water. Rinse thoroughly and dry, or gently rub with cleansing powder or soap-filled pads as directed. DO NOT clean the rack in the self-cleaning oven.</p> <p>If flat racks are cleaned in the oven during the self clean mode, they will lose their shiny finish and may not glide smoothly. If this happens wipe the rack edges with a small amount of vegetable oil. Then wipe off excess.</p>
Telescopic	<p>Wash with soapy water. Rinse thoroughly and dry, or gently rub with cleansing powder or soap-filled pads as directed. Avoid getting cleansing powder in the telescopic slides. Relubrication may become necessary. Use only high-temperature foodgrade lubricants to re-lubricate slides.</p> <p>DO NOT clean the rack in the selfcleaning oven. DO NOT leave the rack in the oven during self clean. If the telescopic rack is cleaned in the oven during the self clean mode it will lose its shiny finish and will not glide smoothly.</p>
Fiberglass Gasket	DO NOT CLEAN GASKET.
Glass	Wash with soap and water or glass cleaner. Use Fantastik or Formula 409® to remove grease spatters and stubborn stains.
Painted Surfaces	Clean with hot soapy water or apply Fantastik or Formula 409 to a clean sponge or paper towel and wipe clean. Avoid using powder cleaning agents, steel wool pads and oven cleaners.
	<p>Immediately wipe up acid spills like fruit juice, milk and tomatoes with a dry cloth. Do not use a moistened sponge/cloth on hot porcelain. When cool, clean with hot soapy water or apply Bon-Ami or Soft Scrub to a damp sponge. Rinse and dry. For stubborn stains, use soap-filled pads. It is normal for porcelain to show fine lines with age due to exposure to heat and food soil.</p>
Stainless Steel Surfaces	<p>Always wipe or rub in the direction of the grain. Clean with a soapy sponge, then rinse and dry, or wipe with Fantastik or Formula 409® sprayed on a paper towel. Protect and polish with Stainless Steel Magic and a soft cloth. Remove water spots with a cloth dampened with white vinegar.</p>

	<p>Do not use any abrasives such as steel wool pads, Softscrub®, or BonAmi.</p> <p>Chlorine or chlorine compounds in some cleaners are corrosive to stainless steel. Check ingredients on label before using</p>
Black Stainless Surfaces	For black stainless steel and antifingerprint surfaces, use a soft, dry towel. For stubborn dirt, use warm water diluted with a non-abrasive, mild cleansing soap. Never use stainless steel polish.
Probe	Wipe with soapy water. Do not submerge. Do not wash in the dishwasher.
Printed Areas (Words and Numbers)	Do not use abrasive cleansers. When cool, clean with soapy water, rinse, dry.
Plastic & Controls	<p>When cool, clean with soapy water, rinse and dry.</p> <p>Do not use any abrasives such as steel wool pads, Softscrub, or BonAmi</p>
Drawer interior (polished stainless steel)	Use dish detergent. Wash, rinse well and dry. For hard water spots or scale, use white vinegar. Apply with a sponge or cloth, rinse, and dry. Chlorine or chlorine compounds in some cleansers are corrosive to stainless steel. Check ingredients on label.
Painted surfaces	Use hot soapy water or mild cleaners such as Fantastik or Formula 409. Wash, rinse well and dry. Avoid using abrasive cleaning agents, steel wool pads and oven cleaners.
Drawer exterior frame (brushed stainless steel)	<p>Always wipe or rub in the direction of the grain. Clean with a soapy sponge, then rinse and dry, or wipe with Fantastik or Formula 409 sprayed on a paper towel. Protect and polish with Stainless Steel Magic and a soft cloth. Remove water spots with a cloth dampened with white vinegar. Use Bar Keeper's Friend® to remove heat discoloration.</p> <p>Chlorine or chlorine compounds in some cleansers are corrosive to stainless steel. Check ingredients on label.</p>

Maintenance

Cooktop Maintenance

The appliance requires only regular cleaning for proper operation. No other maintenance is required.

Oven Maintenance

Replacing an Oven Light

WARNING

- Make sure the appliance and lights are cool and power to the appliance has been turned off before replacing the light bulb(s). Failure to do so could result in electrical shock or burns. The lenses must be in place when using the appliance.
- The lenses serve to protect the light bulb from breaking.
- The lenses are made of glass. Handle carefully to avoid breaking. Broken glass could cause an injury.
- Light socket is live when door is open.

Bulb specifications:

Bulb Description	Bulb Image
40 watt, appliance bulb, standard Edison base	

To change the bulb:

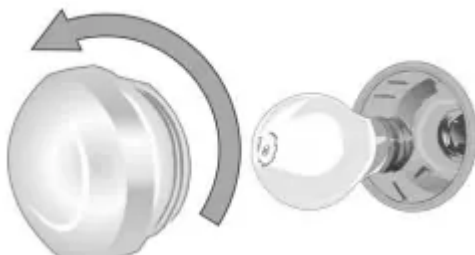

1. Turn off power to the oven at the main power supply (fuse or breaker box).
2. Remove the glass cover by unscrewing it. Turn the glass counterclockwise to remove it.
3. Remove the bulb. The bulb unscrews counterclockwise.

4. Grasp the new bulb with a clean, dry cloth to prevent depositing skin oils on the glass which could lead to premature bulb failure. Replace the bulb by screwing it in turning the bulb clockwise.
5. Screw the glass cover back on.
6. Turn power back on at the main power supply (fuse or breaker box).

Removing the Oven Door

WARNING - When removing the door:

- Make sure oven is cool and power to the oven has been turned off before removing the door. Failure to do so could result in electrical shock or burns.
- The oven door is heavy and parts of it are fragile. Use both hands to remove the oven door. The door front is glass. Handle carefully to avoid breakage.
- Grasp only the sides of the oven door. Do not grasp the handle as it may swing in your hand and cause damage or injury.
- Failure to grasp the oven door firmly and properly could result in personal injury or product damage.
- To avoid injury from hinge bracket snapping closed, be sure that both levers are securely in place before removing the door. Also, do not force door open or closed—the hinge could be damaged and injury could result.
- Do not lay removed door on sharp or pointed objects as this could break the glass. Lay on a flat, smooth surface, positioned so that the door cannot fall over.

To remove the oven door:

To help avoid injury or damage be sure to read the above WARNING before attempting to remove the oven door.

1. Open the oven door to its fully open, horizontal position.
2. Flip levers on hinges toward you.

Note: It may be necessary to use a tool, such as a screwdriver, to gently pry the upper

part of the lever away from the housing. Take care to avoid scratching the housing.

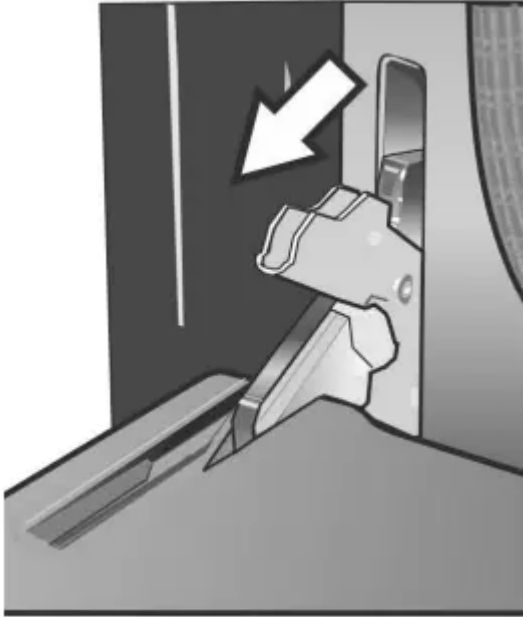

3. Bring both door hinge levers to their fullest down position as shown in the illustration. The left and right door hinge levers may differ slightly but operate in the same manner.
4. Close the oven door until it catches on the hinge stop levers, locking the hinges at the proper angle for door removal. The door will be open about 7 inches at the top. This takes the spring tension off the hinges so the door can be easily lifted out.



5. The door is heavy. Use both hands to firmly grip it by the sides. Do not grip the door by the handle. Maintaining the door angle, lift the door straight up approximately 3/4" to unhook the hinges from the slots and then pull it out towards you until the hinges are

clear of the oven housing.

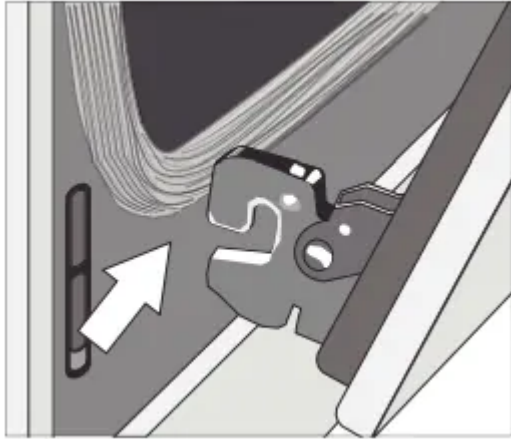

6. Place the door in a convenient and stable location for cleaning.

To replace the oven door:

1. Holding the door firmly in both hands, grip it on either side, not by the handle.
2. Tilt the door back slightly towards you until it opens about 7" at the top.
3. Slide the hinges into the slots as far as they will go and then lower the door straight down. The angle of the door may need to be adjusted slightly to allow the hinges to engage properly and the door to lower into place. The door should lower about 3/4" and stop. If not, the hinges have not engaged properly and the door could fall if it is released.
4. Once both hinges are fully engaged as described in Step 3, gently open the door until it is fully open.

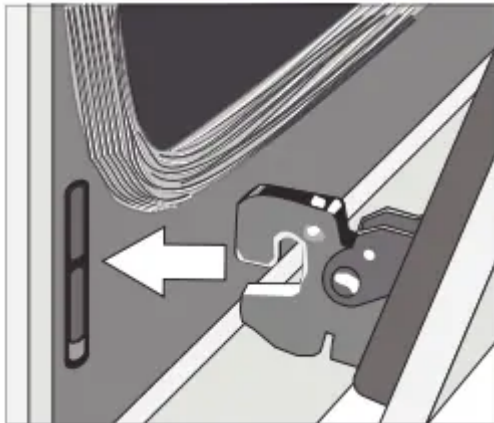

5. Push the levers on both the hinges up and forward until they are locked into the slot, flush with the front of the oven body.

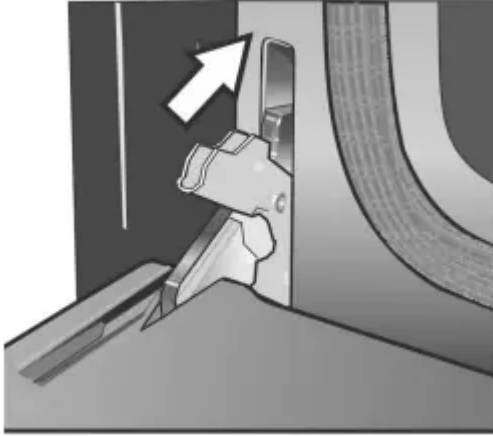

6. Close and open door slowly to be sure it is correctly and securely in place.

Warming Drawer Maintenance

Removing the Drawer

CAUTION: To prevent burns, do not remove drawer while hot. Be sure drawer is empty before removing.

Removing Drawer from Housing

NOTICE: The following is the manufacturer's recommendations for removing and installing the drawer to minimize the risk of damage to the PTO mechanism.

1. Remove the drawer from the drawer housing.
 - Pull drawer to fully open position.
 - Press down right drawer release lever.
 - Lift up left drawer release lever.
 - Firmly pull the drawer straight out.

- Retract cabinet rails while drawer is removed.

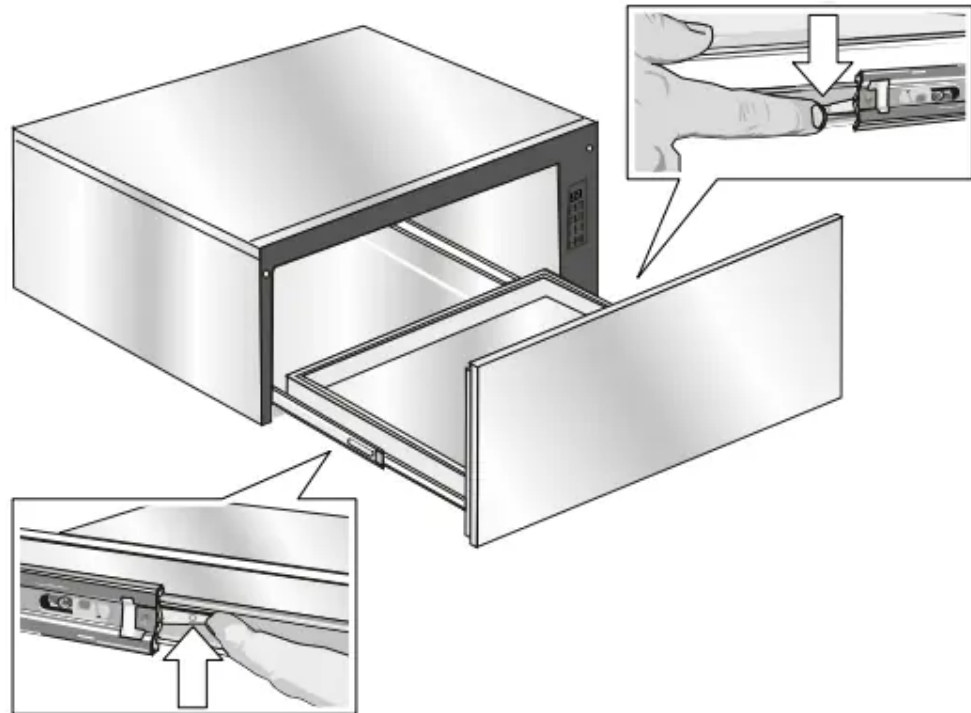

2. Grasp both sides of the drawer and pulling straight and level, carefully remove the drawer housing. This step may require light to moderate force to completely remove drawer.

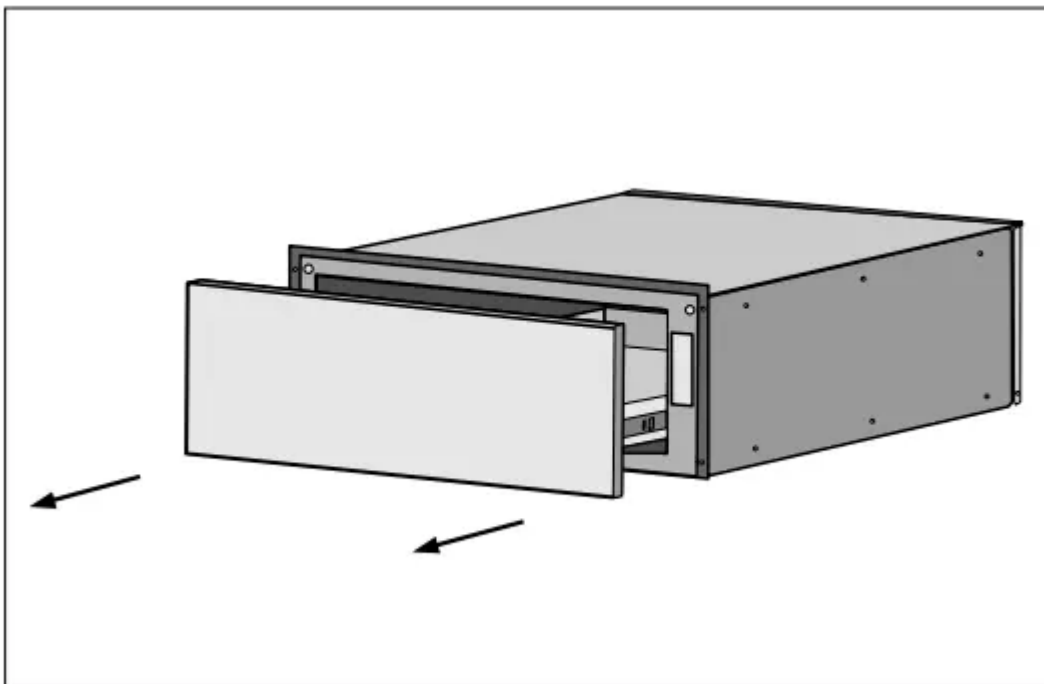

3. Install or service (clean) housing with drawer removed.

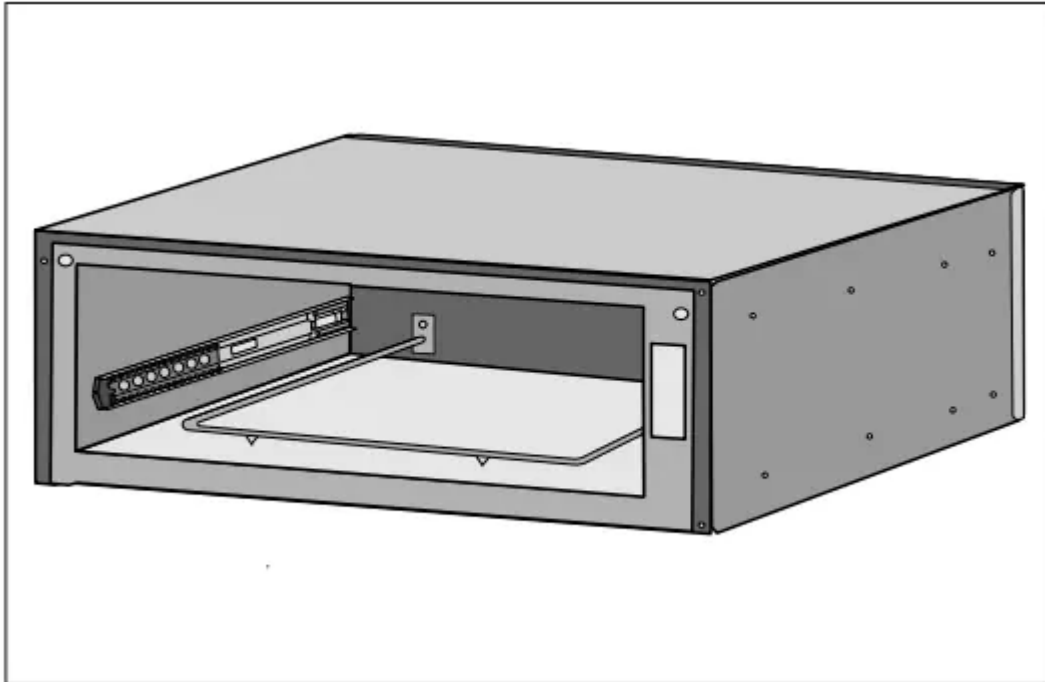

Installing Drawer to Housing

The slides mounted to each side of the housing wall have two moving components, an inner rail and a ball bearing carrier which need to be in the proper orientation for accurate installation and alignment.

There is also a visible locking mechanism located at the rear of each slide.

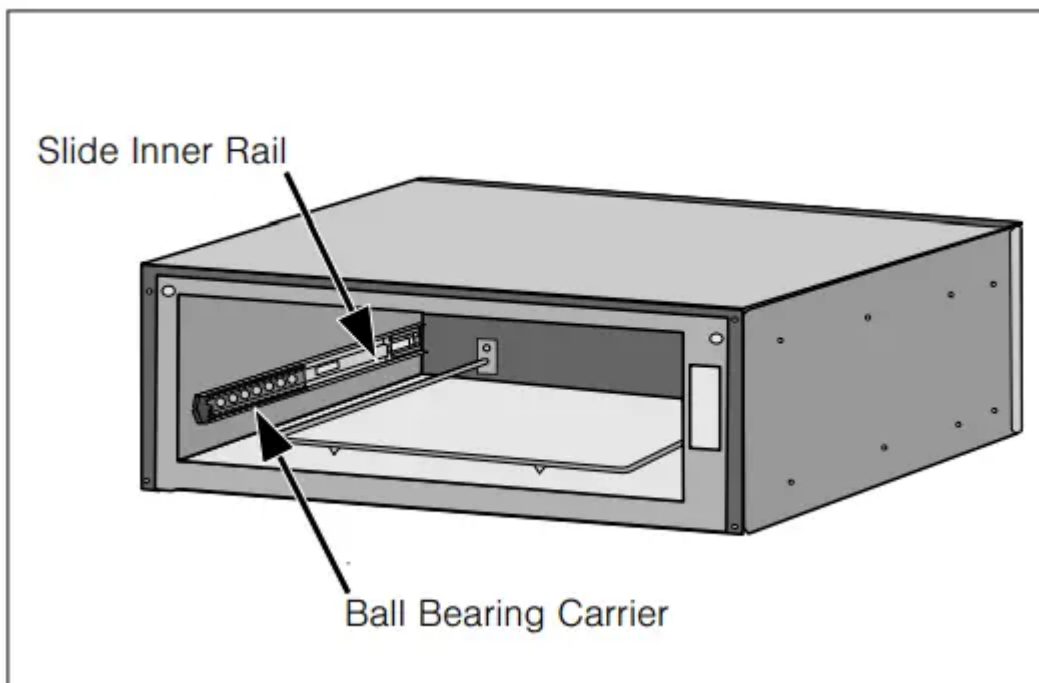

Note: The housing of your warming drawer should match the image below identically before starting your installation. The ball bearing carrier should be locked in to the inner rail's black plastic

rail tip at the front of the inner rail.

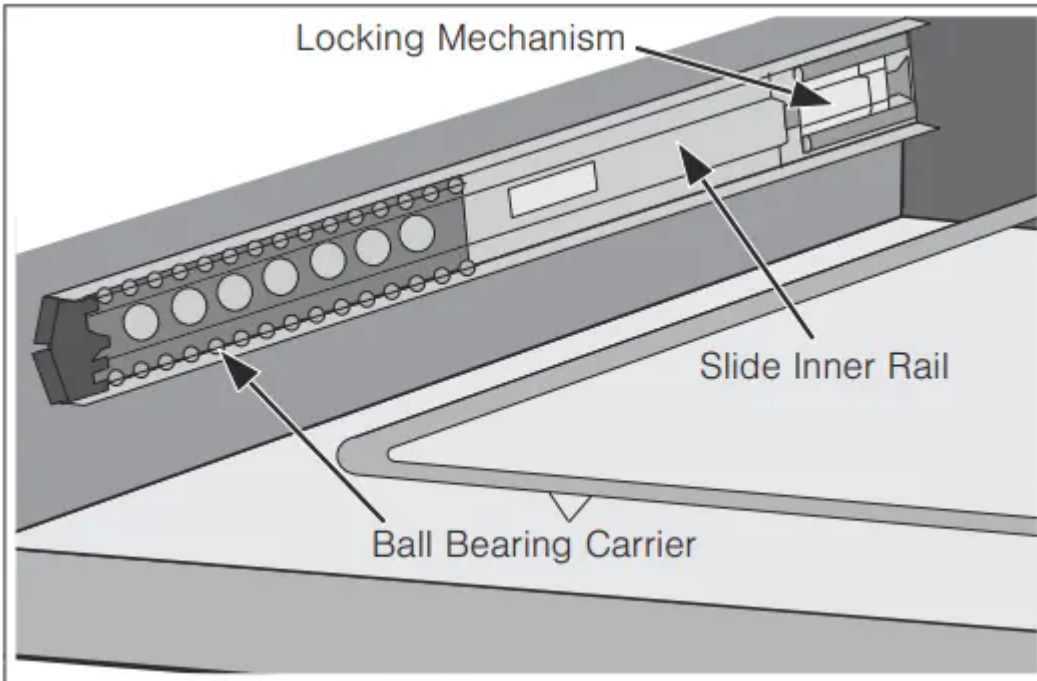

1. With the drawer removed, set the slide inner rail to the drawer locked position by pushing the slide inner rail toward the rear of the housing until it locks in place.

Note: A moderate force pushing on the black plastic ball carrier locking mechanism is required to set the slide to the drawer locked position. The drawer is locked when it remains in place and does not spring back to the open position.

2. Position the drawer assembly in front of the housing assembly and align the rail (plastic rail tip) to the slide ball carrier assembly. Keeping the drawer assembly level and square to the housing, gently insert the drawer to the housing assembly.

Notes: A slight side-to-side wobble motion may be required to properly get the ball bearings to accurately align. Remember: You are attempting to align two sets of ball bearings at this point. If more than a moderate force is required to insert the drawer at this time, remove the drawer and repeat the installation procedure to this point.

3. Continue to insert the drawer keeping the drawer level and square to the housing until a slight increase in resistance is felt at the approximate position shown below.

NOTICES: At this position, a slight increase in closure force is required with several small increments of force applied to the drawer to accurately align and set the drawer for proper operation. An audible “click” should be heard when the drawer is properly closed causing the drawer to lock in the closed position.

4. Test the operation of the PTO drawer by pushing on the center lower portion of the drawer front (optimum location for function).

Note: It should be noted the recommended and optimum location for opening the drawer is the lower center front. The drawer will operate with an opening force applied to any location on the drawer front, however a slight increase in opening force may be required.

Self Help

Cooktop Troubleshooting

Use these suggestions before calling for service to avoid service charges.

Cooktop Problem	Possible Causes and Suggested Solutions
Burner(s) do not light / Igniters do not spark	<ul style="list-style-type: none"> • Make sure that the gas shut off valve is in the ON position and the gas supply to the house is not shut off. • Make sure the burner caps are properly positioned and the burner ports are not clogged. Clear ports with a wire or straightened paper clip if clogged. • Make sure the igniters are clean and dry. • Check the power supply. It should be properly grounded with the correct polarity. Make sure the unit is plugged in and the circuit breaker is not tripped.
Burner flame goes out unexpectedly	<ul style="list-style-type: none"> • Make sure that there is no draft in the room.
Igniters spark even though knobs are in the off position	<ul style="list-style-type: none"> • When the electrical power connection has been activated at the first power up or reconnected after an outage, the igniters may spark once or twice even though all burner knobs are in the off position.
Cooking results are not what was expected	<ul style="list-style-type: none"> • The cooktop is not level. • Cooking pan does not fit the surface being used. • Cookware is not the type or size recommended.
Water takes too long to boil	Time to boil can vary greatly depending on environmental conditions. See “Boiling Water” in this manual for tips to decrease time to boil.

Oven Troubleshooting

Use these suggestions before calling for service to avoid service charges.



Cooktop Problem	Possible Causes and Suggested Solutions
The oven mode or temperature selected or the numbers selected do not appear in the display	Review manual instructions when setting clock, timer, or Self-Clean.
Oven door is locked and will not release, even after cooling	Turn the oven off at the circuit breaker and wait 5 minutes. Turn breaker back on. The oven should reset itself and will be operable.
Oven is not heating	Be sure oven temperature has been selected. Check regulator switch as it may be off.
Oven is not cooking evenly	Adjust oven calibration if necessary (see “Change the Oven Temperature Offset” in this manual). Refer to cooking charts for recommended rack position.
Baking results are not as expected	Refer to cooking charts for recommended rack position. Check “Getting the Most Out of Your Oven” on page 24 for tips and suggestions. Adjust oven calibration if necessary (see “Change the Oven Temperature Offset” in this manual).
Food takes longer to cook than expected	The oven is carefully calibrated to provide accurate results. However, the temperature can be offset if food is consistently too brown or too light. See “Oven Temperature Offset”.
Food is overcooked	The oven is carefully calibrated to provide accurate results. However, the temperature can be offset if food is consistently too brown or too light. See “Oven Temperature Offset”.
Convection Bake Results are not as Expected	If the Automatic Convection Conversion Feature is turned off, the temperature must be manually reduced by 25° F. If the feature is active, the temperature is automatically adjusted. See “Turn Automatic Convection Conversion ON or OFF” for more information. Refer to cooking charts and tips for rack positions, cooking times and pan selection. Adjust oven calibration if necessary. See “Oven Temperature Offset”.



Oven temperature is too hot or too cold	The oven thermostat needs adjustment. See “Oven Temperature Offset”.
Oven light is not working properly	Replace or reinsert the light bulb if loose or defective. Touching the bulb with fingers may cause the bulb to burn out.
Oven light will not turn off	Check for obstruction in oven door. Check to see if hinge is bent. When the Sabbath feature is activated, the oven light will stay on or off (as selected during set-up) during the entire Sabbath mode.
Cannot remove lens cover on light	There may be soil build-up around the lens cover. Wipe lens cover area with a clean dry towel prior to attempting to remove the lens cover.
Oven will not Self-Clean properly	Allow the oven to cool before running Self-Clean. Always wipe out loose soils or heavy spillovers before running Self-Clean. If oven is badly soiled, set oven for a four-hour Self-Clean. See Preparing the Oven to Self-Clean.
Clock and timer are not working properly	Make sure there is electrical power to oven. See Clock and Timer sections.
Porcelain chips	When oven racks are removed and replaced, always tilt racks upward and do not force them to avoid chipping the porcelain. “
“E” and a number appears in display and control beeps	This is a fault code. Press Off to clear the display and stop beeping. Reset oven if necessary. If fault code remains and beep continues, record fault code, cancel oven and call authorized service technician.
With a new range there is a strong odor when oven is turned on	This is normal with a new range and will disappear after a few uses. Operating the self-clean cycle will also “burn-off” the smell more quickly.
Control does not react when the pad is touched	Be sure that pad is clean. Touch the center of the touchpad. Use the flat part of your finger.
Fan is running during modes that don’t use convection	On some models, the convection fan will run while the oven is preheating for the bake mode. This is normal.



	Slide-in models also have a cooling fan that runs during every cooking mode.
Warm air or steam escapes from oven vent	It is normal to see or feel steam or warm air escaping from the oven vent. Do not block the vent.
Cooling fan runs after oven is turned off (Slide-in ranges only)	This is normal. When the oven has cooled to a pre-determined temperature, the cooling fan turns off.

Warning

This content is compiled from multiple sources and is provided for reference purposes only. It may not be complete or fully applicable to all situations. If you are unable to resolve your issue, please contact the product manufacturer or an authorized service provider for official support.