

Equipment Description

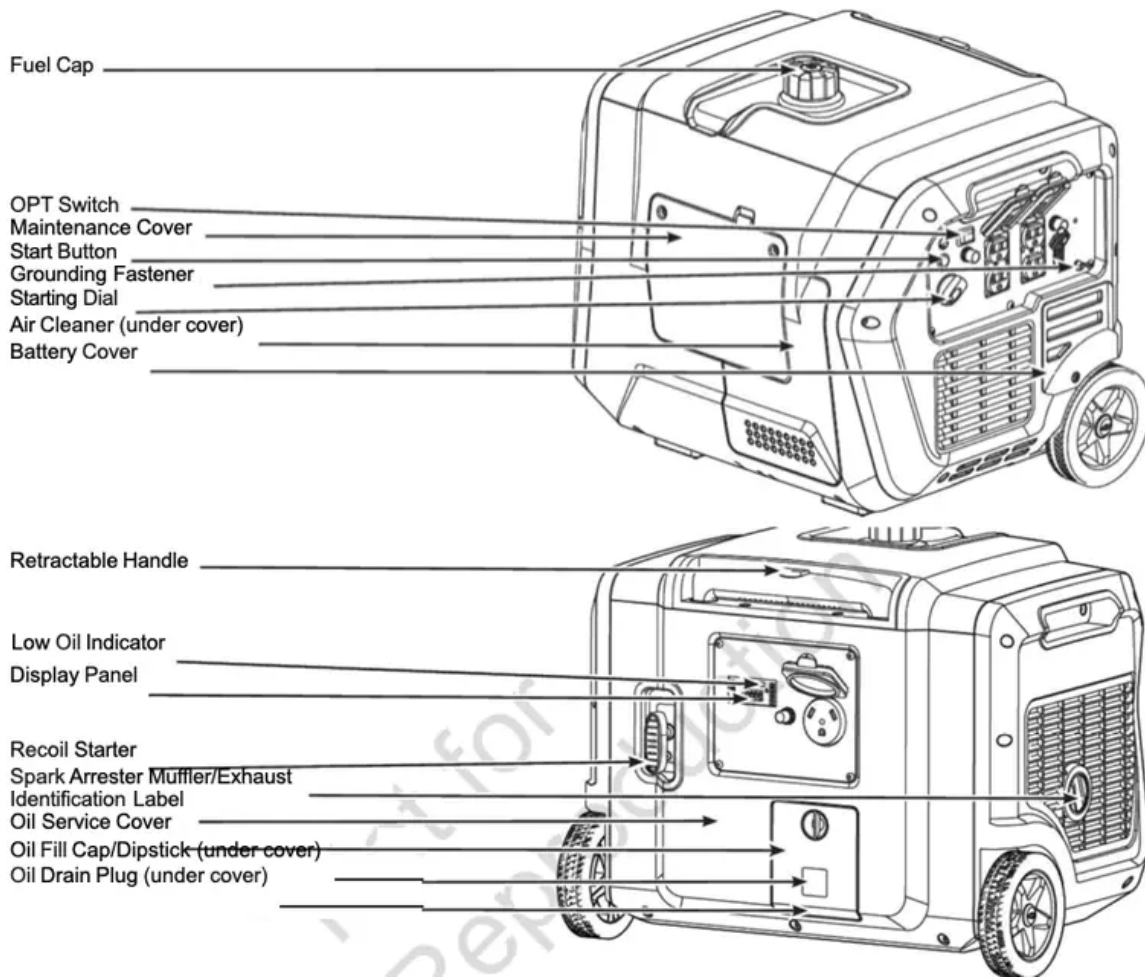

Air Cleaner — Filters engine intake air.

Battery Cover — Remove to gain access to the battery. Fuel Cap — Add unleaded fuel here.

Grounding Fastener — Consult your local agency having jurisdiction for grounding requirements in your area.

Display Panel — The LED displays voltage, frequency and records how many hours your generator has run (up to 999.9). It also has a built in maintenance reminder that displays every 50 hours.

Identification Label — Provides model and serial number of generator.

Low Oil Indicator — This unit is equipped with a low oil protection device. Oil must be at proper level for engine to run. If the engine oil drops below a preset level, an oil switch will stop the engine. Check oil level with dipstick.

Maintenance Cover — Remove to gain access to the choke lever, spark plug and air cleaner.

Oil Drain Plug — Drain engine oil here.

Oil Fill Cap/Dipstick — Check and add engine oil here.

Oil Service Cover — Remove to gain access to the oil fill and drain.

QPT (QUIET POWER TECHNOLOGY) Switch — Use this switch to turn the QPT on or off.

Recoil Starter — Used to start the engine manually.

Retractable Handle — Press button and pull handle out to move generator. Press button to push handle back in.

Spark Arrester Muffler/Exhaust — Lowers engine noise and is equipped with a spark arrested screen.

Start Button — Push and hold for one second to start generator.

Starting Dial — Move dial to COLD START when starting a cold engine. Move dial to RUN when restarting a warm engine or after engine starts. Move dial to OFF to stop engine, during storage and transporting.

Features and Controls

Compare the illustrations with your generator to familiarize yourself with the locations of various controls and product warnings.

⚠ WARNING

Fuel is flammable which could cause burns resulting in death or serious injury.

- Turn engine off and let it cool at least 2 minutes before refueling.
- Do not fill fuel above fuel level indicator.
- Never add fuel to a hot or running generator.

80081784

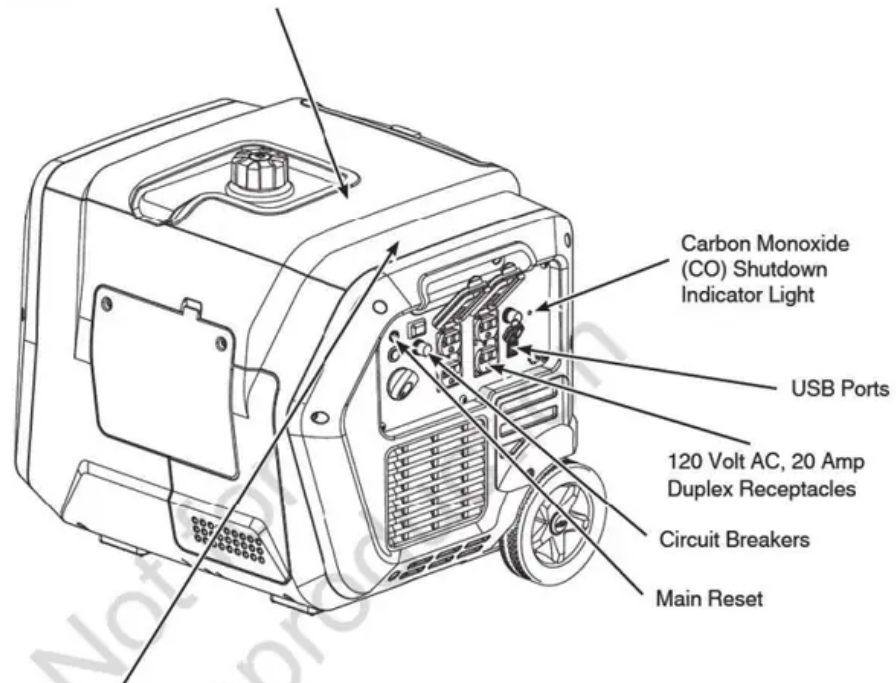
AUTOMATIC SHUTOFF- YOU MUST:

Move generator to an open, outdoor area. Point exhaust away from homes. Don't run generator in enclosed areas (e.g. not in house or garage). Air out premises (e.g. open windows and doors) before reoccupying.

20 FT. (6.1 m) MIN.

Move to fresh air and get medical help if sick, dizzy or weak.

80086224

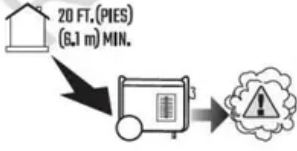

120 Volt AC, 20 Amp, Duplex Receptacle — Used to supply 120 Volt AC, single phase, 60 Hz power for electrical lighting, appliance, tool and motor loads.

120 Volt AC, 30 Amp Travel Trailer Receptacle (see page 5) — May be used to supply electrical power for the operation of 120 Volt AC, 30 Amp, single phase, 60 Hz electrical, travel trailer loads.

Circuit Breakers (AC) — Push-to-reset circuit breakers are provided to protect the generator against electrical overload.

Carbon Monoxide (CO) Shutdown Indicator Light — Indicates the engine shutdown due to carbon monoxide accumulation around the generator or a CO system fault occurred.

Main Reset — Push to reset generator if overloaded.

USB Ports — Use ports to recharge most USB powered devices.

↑ **Point engine exhaust away from all homes.** ↑
 ↑ **Apunte el escape del motor lejos de las casas.** ↑

⚠ DANGER

 Failure to follow warnings, instructions and operator's manual will result in death or serious injury.

 Tampering with the CO Shutdown System will cause Carbon Monoxide poisoning. Install Carbon Monoxide alarms inside home.

 Generator could cause electrical shock.

- Do not run indoors to avoid wet conditions.
- Do not run in rain or wet weather.
- Do not connect to a home's electrical system.

 Hot exhaust gases could cause fires. Keep at least 5 ft. (1.5 m) clearance from any combustibles or structures, including overhead.

⚠ DANGER

Using a generator indoors **CAN KILL YOU IN MINUTES.** Generator exhaust contains carbon monoxide. This is a poison you cannot see or smell.



NEVER use inside a home or garage, EVEN IF doors and windows are open.



Only use OUTSIDE and far away from windows, doors, and vents.

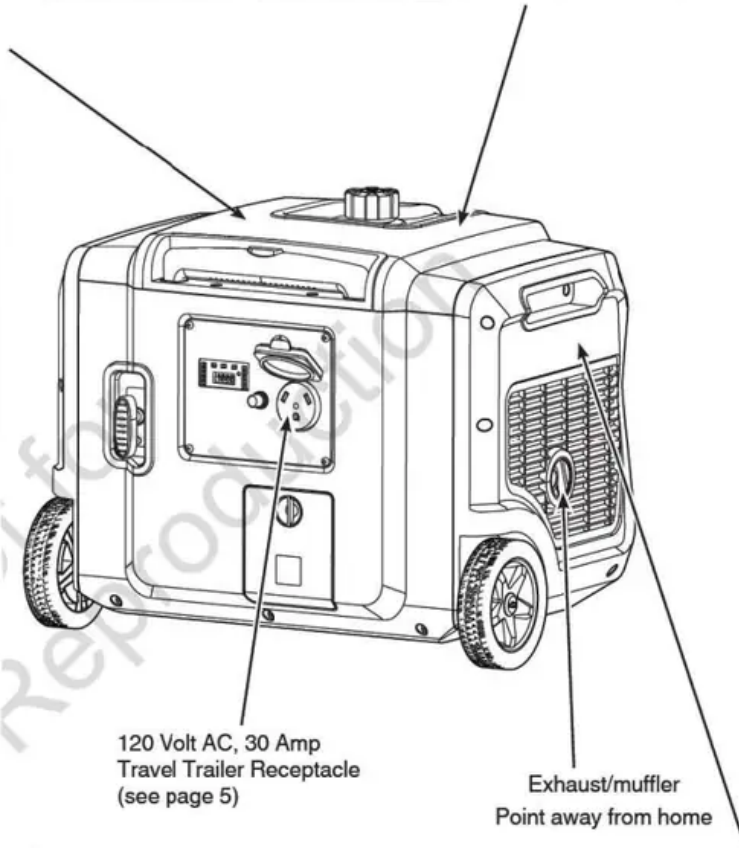

⚠ WARNING

Muffler could cause burns resulting in serious injury.

- Do not touch hot parts
- Avoid hot exhaust gases



Operation

Step 1: Safe Location

Before starting the portable generator there are two equally important safety concerns regarding carbon monoxide poisoning and fire that must be addressed.

Operation Location to Reduce the Risk of Carbon Monoxide Poisoning



The engine exhaust of all fossil fuel burning equipment, such as a portable generator, contains carbon monoxide, a poisonous gas that will kill you in minutes. You cannot smell it, see it, or taste it. Even if you do not smell exhaust fumes, you could still be exposed to carbon monoxide gas.

By law it is required in many states to have a carbon monoxide alarm in operating condition in your home. A carbon monoxide alarm is an electronic device that detects hazardous levels of carbon monoxide. When there is a buildup of carbon monoxide, the alarm will alert the occupants by flashing visual indicator light and alarm. Smoke alarms cannot detect carbon monoxide gas.

Carbon Monoxide Alarm(s)

Install carbon monoxide alarms warning carbon monoxide alarms, you will not realize you are getting sick and dying from carbon monoxide poisoning.

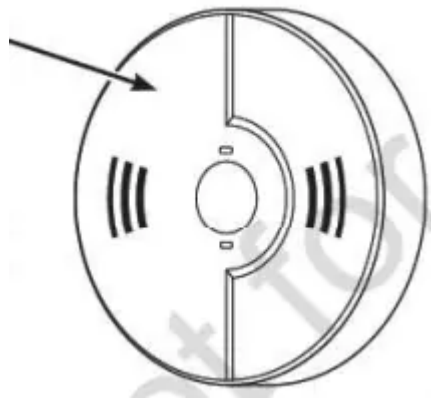

DANGER! Engine exhaust contains carbon monoxide, a poisonous gas that will kill you in minutes. You cannot smell it, see it, or taste it. Even if you do not smell exhaust fumes, you could still be exposed to carbon monoxide gas.

- Operate portable generator only outdoors, at least 20 ft. (6.1 m) from occupied spaces with exhaust pointed away to reduce the risk of carbon monoxide accumulating.
- Install battery-operated carbon monoxide alarms or plug-in carbon monoxide alarms with battery back-up according to the manufacturer's instructions. Smoke alarms cannot detect carbon monoxide gas.
- Do not run portable generator inside homes, garages, basements, crawlspaces, sheds, or other partially- enclosed spaces even if using fans or opening doors and windows for ventilation. Carbon monoxide can quickly build up in these spaces and can linger for hours, even after this product has shut off.

If you start to feel sick, dizzy, weak, or your homes carbon monoxide alarm sounds while using this product, get to fresh air right away. Call emergency services. You may have carbon monoxide poisoning.

Prevent Carbon Monoxide (CO) Poisoning

- Use outdoor at least 20 ft (6.1m) from any home.
- Point exhaust away from all homes and occupied spaces

- Install CO alarms inside your home.

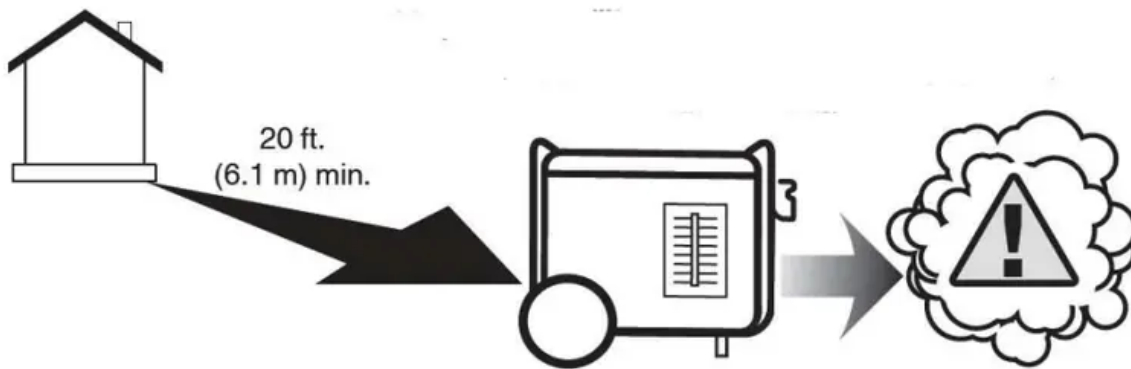

Operation Location to Reduce the Risk of Fire

WARNING! Exhaust heat/gases could ignite combustibles, structures or damage fuel tank causing a fire, resulting in death or serious injury.

- Portable generator must be at least 5 ft. (1.5 m) from any structure, overhang, trees, shrubs, or vegetation over 12 in. (30.5 cm) in height.
- Do not place portable generator under a deck or other type of structure that may confine airflow. Smoke alarm(s) must be installed and maintained indoors according to the manufacturer's instructions/recommendations.
- carbon monoxide alarms cannot detect smoke.
- Do not place portable generator in manner other than shown

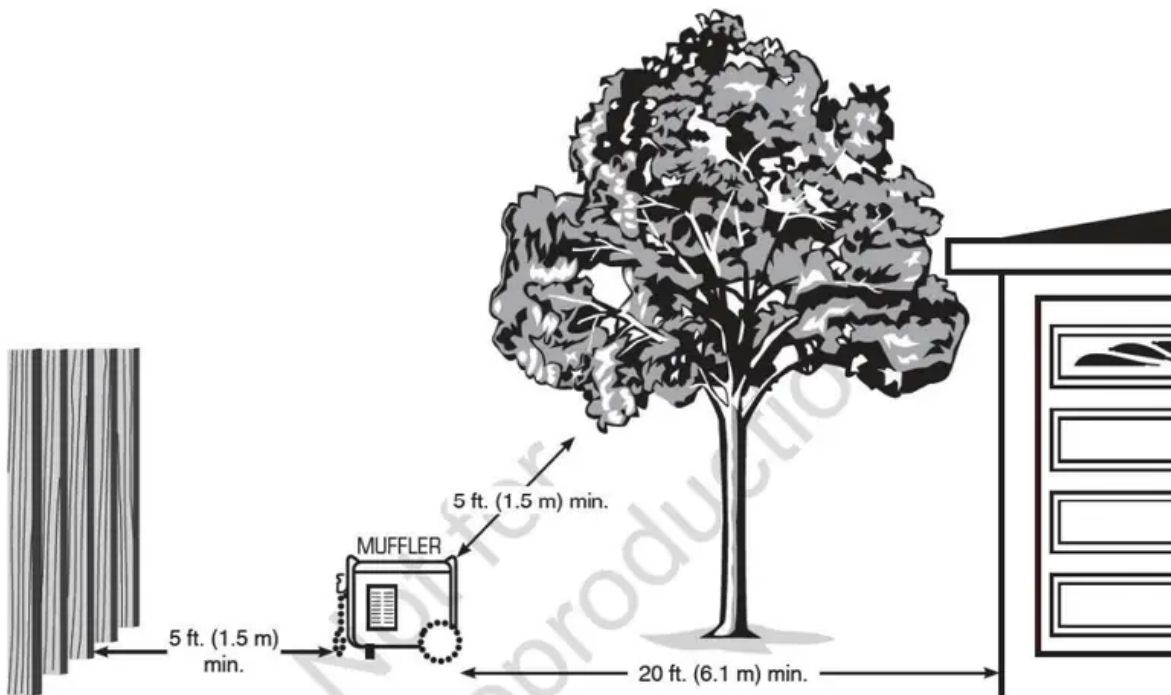

Step 2: Oil and Fuel

1. Move generator outdoors to a flat, level surface.
2. Turn dial and open cover over oil fill area.

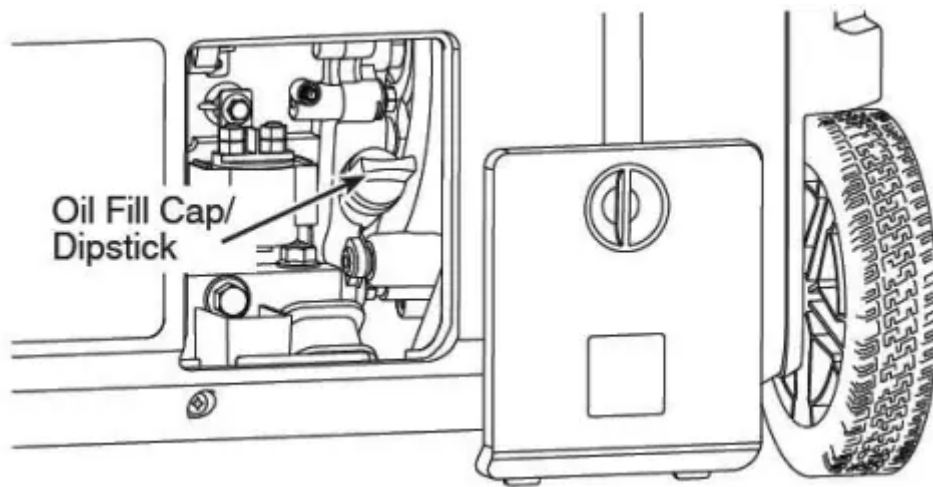

3. Clean area around oil fill and remove oil fill cap/dipstick.
4. Using an oil funnel, slowly pour contents of oil bottle into oil fill opening. Checking oil level frequently, fill to point of overflowing.

NOTICE Do not screw in dipstick when checking oil level.

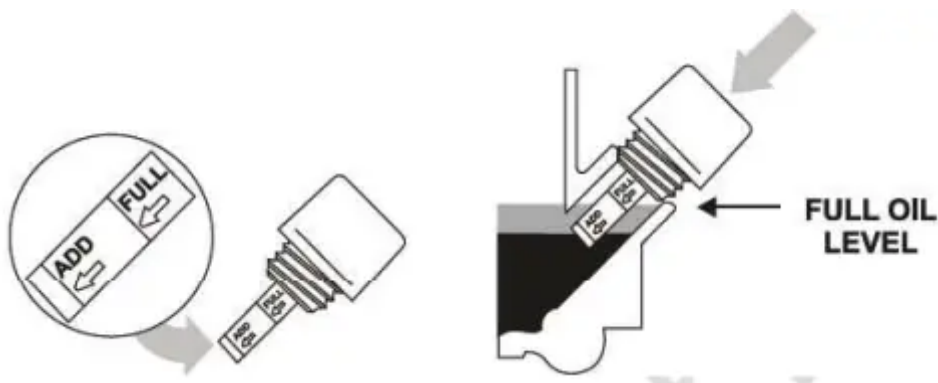

NOTICE Pause to permit oil to settle. Wipe dipstick clean each time oil level is checked. DO NOT overkill.

5. Replace and fully tighten oil fill cap/dipstick.
6. Replace cover over oil fill area.

Low Oil Indicator

The low oil indicator system is designed to prevent engine damage caused by not enough engine oil. If engine oil level drops below a preset level, the yellow LED low oil indicator light comes on and an oil level switch will stop the engine. If engine stops or the yellow LED low oil indicator light comes on when you try to start the generator, check the engine oil level.

Fuel Level Monitor

There are 5 LED's to indicate the level of fuel in the fuel tank. The yellow bottom LED indicates your fuel tank is empty or near empty. The remaining 4 green LED's indicate the fuel level in 25% increments from the bottom to the top; 25%, 50%, 75% and 100%.

Fuel must meet these requirements:

- Clean, fresh, unleaded fuel with a minimum of 87 octane.
- Gasoline with an ethanol content up to 10% is acceptable.



NOTICE Do not mix oil in fuel or modify engine to run on alternate fuels. Use of unapproved fuels could damage engine and will not be covered under warranty.

See *High Altitude* for 5,000 ft. and above.

WARNING! Fuel and its vapors are extremely flammable which could cause burns or fire resulting in death or serious injury.

- Do not refuel during operation.
- Do not smoke during refueling.
- Turn engine off and let it cool at least 2 minutes before removing fuel cap.
- Fill fuel tank outdoors. Keep fuel away from sparks, open flames, pilot lights, heat, and other ignition sources. Check fuel lines, tank, cap and fittings frequently for cracks or leaks. Replace if necessary.

7. Slowly remove fuel cap to relieve pressure in tank.

8. Slowly add unleaded fuel to red max fill indicator in fuel tank. Be careful not to fill above the indicator. This allows adequate space for fuel expansion.

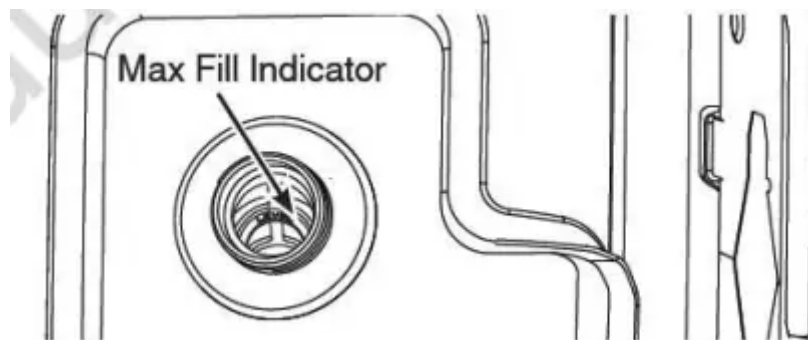

9. Install fuel cap and let any spilled fuel evaporate before starting engine.

High Altitude

At altitudes over 5,000 ft. (1524 m), a minimum 85 octane fuel is acceptable. To remain emissions compliant, high altitude adjustment is required. Operation without this adjustment will cause decreased performance, increased fuel consumption, and increased emissions.

See an authorized Briggs & Stratton dealer for high altitude adjustment information. Operation of the engine at altitudes below 2,500 ft. (762 m) with the high altitude kit is not recommended.

Transporting

When transporting equipment, turn starting dial to off position. Do not tip engine or equipment at an angle which causes fuel to spill.

Step 3: Generator Start Up

Disconnect all electrical loads from the generator. Use the following start instructions:

1. Make sure unit is outdoors on a level surface. **NOTICE** Failure to operate the unit on a level surface may cause the unit to shut down.
2. Turn starting dial to the cold start position.

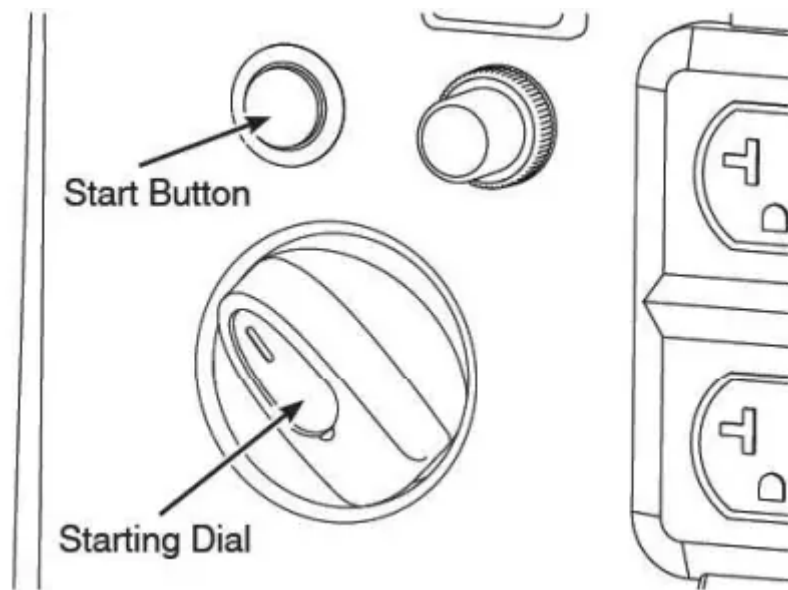

NOTICE For a warm engine, turn starting dial to the run position.

3. Press and hold the start button until generator starts. DO NOT press and hold start button for more than 5 seconds. Pause for at least 30 seconds between starting attempts.

NOTICE If battery is discharged, grasp recoil handle and pull slowly until slight resistance is felt. Then pull rapidly one time only to start engine.

4. Slowly turn starting dial to run position. If engine falters, turn starting dial halfway between cold start and run position until engine runs smoothly, and then to run position.

NOTICE If engine starts but fails to run, see *Low Oil Indicator*.

Step 4: Connecting Electrical Loads

Using Extension Cords

1. Only use grounded cords marked for outdoor use rated for your loads.

To provide power using extension cords		
Total Amperage	Minimum Gauge, Outdoor Rated	
	Up to 50 FT (15 M)	Up to 100 FT (30 M)
Up to 13A	16	14
Up to 15A	14	12
Up to 20A	12	10
Up to 30A	10	8

2. Follow cord safety instructions.
3. Install carbon monoxide alarm(s).
4. When operating generator with extension cords, make sure it is located in an open, outdoor area, at least 20 ft. (6.1 m.) from occupied spaces with exhaust pointed away.
5. Extension cords running directly into home, powering indoor items IS NOT RECOMMENDED.

DANGER! Engine exhaust contains carbon monoxide, a poisonous gas that will kill you in minutes. You cannot smell it, see it, or taste it.

Even if you do not smell exhaust fumes, you could still be exposed to carbon monoxide gas.

- Extension cords running directly into the home increase your risk of carbon monoxide poisoning through openings.
- If an extension cord running directly into the home is used to power indoor items, the operator recognizes that this increases the risk of CO poisoning to people inside the home and assumes that risk.

WARNING! Damaged or overloaded extension cords could overheat, arc, and burn resulting in death or serious injury.

NOTICE For generator output required see *Generator Capacity*. Connect electrical loads in off position then turn on for operation.

5 Volt DC USB Ports

The maximum current available for the USB ports is 2.1 Amps at 5 Volts. The USB port allows you to recharge most USB powered devices with a USB charging cable (not included).

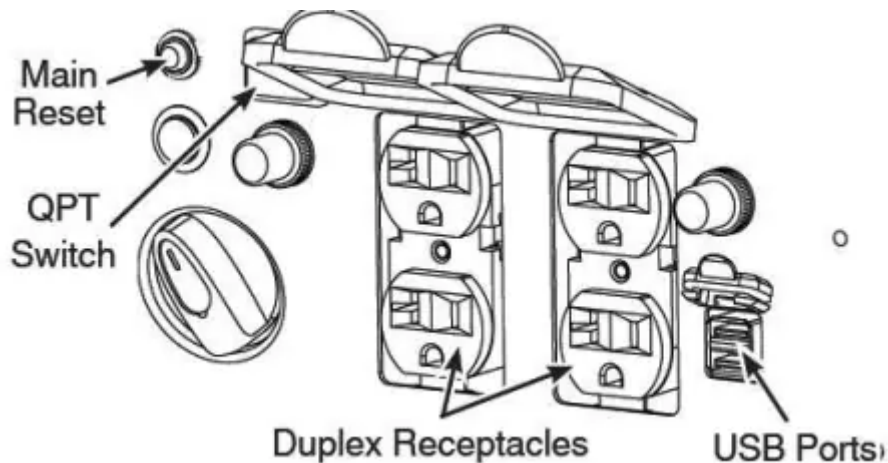

NOTICE For maximum output, use the bottom USB port.

NOTICE For charging ITE (Information Technology Equipment) only.

120 Volt AC, 20 Amp, Duplex Receptacle

Use this receptacle to operate 120 Volt AC, single-phase, 60 Hz electrical loads requiring up to 2,400 Watts (2.4 kW) at 20 Amps of current.

120 Volt AC, 30 Amp, Travel Trailer Receptacle

Use a NEMA TT—30 plug with this receptacle. Connect a 3—wire travel trailer cord set rated for 125 Volt AC loads at 30 Amps to the plug.

This receptacle powers 120 Volt AC, 60 Hz, single phase travel trailer loads requiring up to 3,600 watts (3.6 kW) of power at 30 Amps.

Power Use

The power use monitor indicates percentage of total generator load using LED's. The first green LED indicates generator is operating normally or producing more than 5% load. The second green LED comes on after 25% load is reached, the third green LED comes on after 50% is reached, the fourth green LED comes on after 75% load is reached and the last green LED comes on after 100% load is reached.

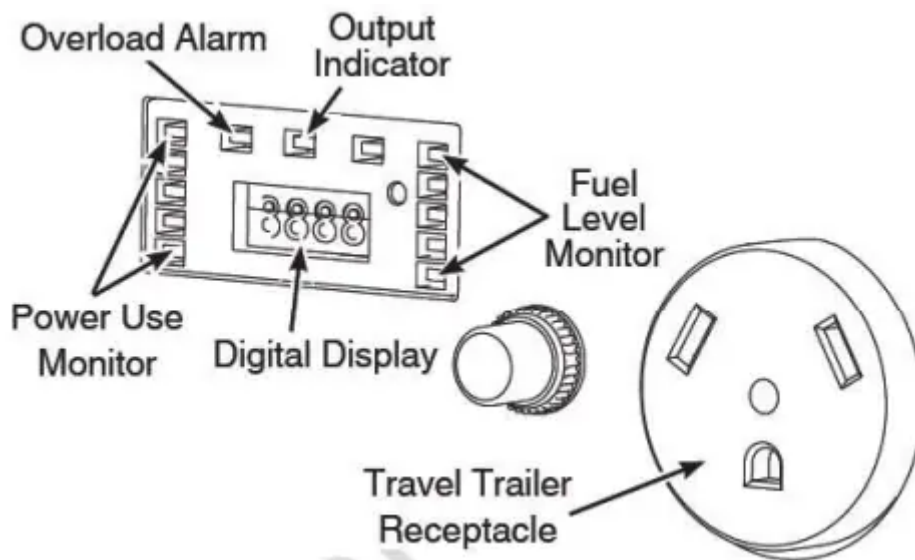

Output Indicator OK!

The green LED output indicator light comes on when the generator is operating normally.

Overload Alarm

The red LED overload alarm light flashes when near an overload and is steady if you overload the generator. The green output indicator light will also go off. If the generator was overloaded, you must turn off all electrical loads, then push the generator main reset button to continue operating.

Digital Display

The digital display will scroll through the voltage, frequency and generator total run time every 5 seconds.

OPT (QUIET POWER TECHNOLOGY)

This feature is designed to greatly improve fuel economy. When QPT is on, engine speed increases as loads are connected, and decreases as loads are removed. When QPT is off, engine will run at full governed speed.

Generator Capacity

To make sure your generator can supply enough running watts and starting watts for the items you will power at the same time, follow these three simple steps:

1. Select the items you will power at the same time. See following list for typical wattages.

Tool or Appliance	Running Watts*	Starting Watts**
Light Bulb - 75 Watt	75	-
Refrigerator/Freezer	550	1350
Window AC - 10,000 BTU	1000	2100
Microwave Oven - 1000 Watt	1000	-
Plasma Television - 50"	500	-
Laptop	250	-

* Typical wattages listed are approximate only. Check tool or appliance for actual wattage.

** The momentary electrical current the generator can provide to start electric motors, per Briggs & Stratton standard 628K. It does not represent the power required to continuously run electrical loads. It is the maximum current that can momentarily be supplied when starting a motor, multiplied by the generator's rated voltage.

2. Total the running watts. This is the amount of power your generator must produce to keep your items running. See following example:

Tool or Appliance	Running Watts	Starting Watts
Window AC - 10000 BTU	1000	2100
Refrigerator/Freezer	550	1350
Plasma Television	500	—
Light (75 Watts)	75	—
	2125 Total Running Watts	2100 Highest Starting Watts

3. Estimate the starting watts you will need. Because not all motors start at the same time, total starting wattage can be estimated by adding only the item with the highest additional starting watts requirements to the total running watts from step 2.

Power Management

To manage generator power, sequentially add loads as follows:

1. With nothing connected to generator, start the engine outdoors.
2. Plug in and turn on the first load, preferably the largest load you have.
3. Permit the generator output to stabilize (engine runs smoothly and attached device operates properly).
4. Plug in and turn on the next load.
5. Again, permit the generator to stabilize.
6. Repeat steps 4 and 5 for each additional load.



Never add more loads than the generator capacity. Take special care to consider starting watts in generator capacity.

Carbon Monoxide (CO) Shutdown System

Automatically shuts down the engine when harmful levels of carbon monoxide accumulate around the generator or a CO shutdown system fault occurs. After shutdown, the indicator light will blink for at least five minutes per the chart below.

The CO shutdown system DOES NOT replace carbon monoxide alarms. Install battery-powered carbon monoxide alarm(s) in your home. Do not run generator in enclosed areas

Color/Pattern	Description
Red 	Carbon monoxide accumulated around generator. Move generator to an open, outdoor area 20 ft. (6.1 m) from occupied spaces with exhaust pointed away. Automatic shutoff is an indication generator was improperly located. Air out premises (e.g. open windows and doors) before reoccupying. If you start to feel sick, dizzy, weak, or your homes carbon monoxide alarm sounds while using this product, get to fresh air right away. Call emergency services. You may have carbon monoxide poisoning.
Blue	CO shutdown system fault occurred*. See Briggs & Stratton authorized service dealer.

*Blue light will blink for five seconds at the startup of generator to show the CO shutdown system is functioning properly.

Step 5: Generator Shutdown

1. Turn off and unplug all electrical loads from generator panel receptacles. Never stop engine with electrical devices plugged in and turned on.
2. Let engine run at no-load for one minute to stabilize internal temperatures of engine and generator.
3. Turn starting dial counterclockwise to the off position.



Maintenance

Maintenance Schedule

Follow the hourly or calendar intervals, whichever occurs first. More frequent service is required when operating in adverse conditions noted below.

First 5 Hours
<ul style="list-style-type: none">• Change engine oil
Every 8 Hours or Daily
<ul style="list-style-type: none">• Clean debris
<ul style="list-style-type: none">• Check engine oil level
Every 50 Hours or Yearly
<ul style="list-style-type: none">• Clean engine air cleaner'
Every 100 Hours or Yearly
<ul style="list-style-type: none">• Change engine oil
<ul style="list-style-type: none">• Service spark plug
<ul style="list-style-type: none">• Inspect muffler and spark arrester
<ul style="list-style-type: none">• Check/Adjust valve clearance
<ul style="list-style-type: none">• Clean fuel tank and filter
Every 250 Hours
<ul style="list-style-type: none">• Clean combustion chamber

Service more often under dirty or dusty conditions.

See any authorized dealer for service.

General Recommendations

Regular maintenance will improve the performance and extend the life of the generator. See any Briggs & Stratton Authorized Service Dealer for maintenance and service.

The generator's warranty does not cover items that have been subjected to operator abuse or negligence. To receive full value from the warranty, the operator must maintain the generator as instructed in this manual.

All service and adjustments should be made at least once each season. A new spark plug and clean air filter assure proper fuel-air mixture and help your engine run better and last longer. Follow requirements in Maintenance *Schedule*.

Maintenance Reminder

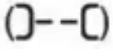
The digital display will flash a maintenance prompt  every 50 hours of run time. It will flash every one second for 6 minutes before it resets automatically. It will also automatically reset if the generator is shut down during the 6 minutes.

Emissions Control

Maintenance, replacement, or repair of the emissions control devices and systems may be performed by any non-road engine repair establishment or individual.

However, to obtain "no charge" emissions control service, the work must be performed by a factory authorized dealer. See *Emissions Warranty*.

The emissions control system for carbureted engines is EM (Engine Modifications). The emissions control systems for engines with electronic fuel injection are ECM (Engine Control Module), MPI (Multi Port Injection), and if equipped an O2S (Oxygen Sensor).

- Generator is equipped with a G-trim engine.

Cleaning

Daily or before use, look around and underneath the generator for signs of oil or fuel leaks. Clean any accumulated debris. Keep area around muffler free from any debris.

- Use a soft bristle brush to loosen caked on dirt or oil.
- Use a damp cloth to wipe exterior surfaces clean.

NOTICE Improper treatment of generator could damage it and shorten its life. Do not expose generator to excessive moisture, dust, dirt, or corrosive vapors. Do not insert any objects through cooling slots.

Battery Maintenance

The generator is equipped with an automatic battery charging circuit that charges the battery while the engine is running. If the generator isn't used frequently, the battery should be connected to a trickle charger or battery maintainer (not included) to keep it properly charged.

1. Remove panel from in front of the battery.

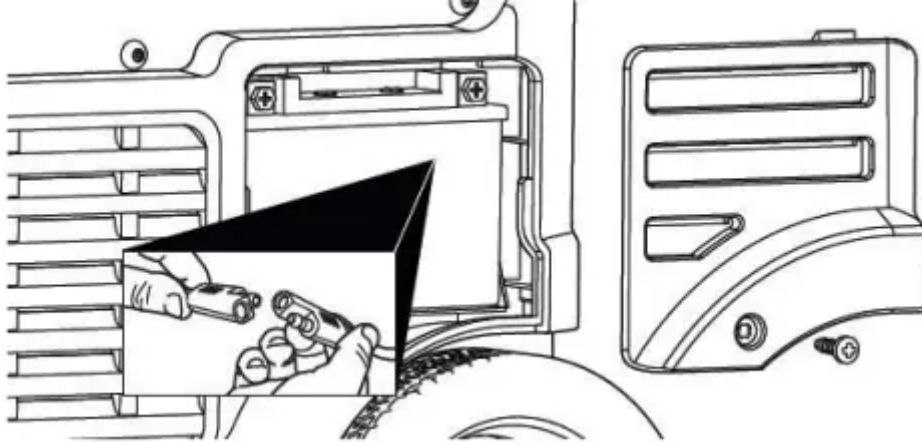

2. Disconnect the two pin connector from the battery to the generator.

NOTICE Do not exceed 1.5 Amp charging rate.

3. Follow the instructions included with the trickle charger or battery maintainer.

Engine Maintenance

Oil Recommendations

We recommend the use of Briggs & Stratton Warranty Certified oils for best performance. Other high-quality detergent oils are acceptable if classified for service SF or higher. Do not use special additives. See *Common Service Parts*.

Outdoor temperatures determine the proper oil viscosity for the engine. Use the chart to select the best viscosity for the outdoor temperature range expected.

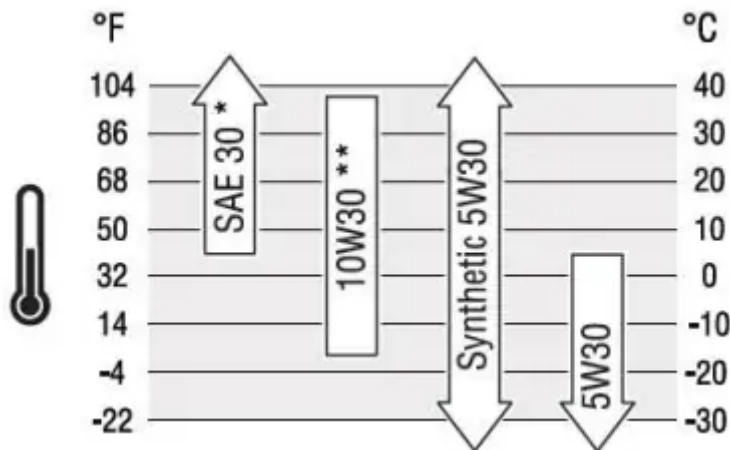

* Below 4°C (40°F) the use of SAE 30 will result in hard starting.

** Above 27°C (80°F) the use of 10W30 may cause increased oil consumption. Check oil level more frequently.

Checking/Adding Engine Oil

Oil level should be checked prior to each use or at least every 8 hours of operation. Keep oil level maintained.

1. Make sure generator is on a level surface.
2. Remove cover over the oil fill area.
3. Clean area around oil fill, remove dipstick and wipe with clean cloth. Replace dipstick. Remove and check oil level.

NOTICE Do not screw in dipstick when checking oil level.

4. Verify oil is at full mark on dipstick.

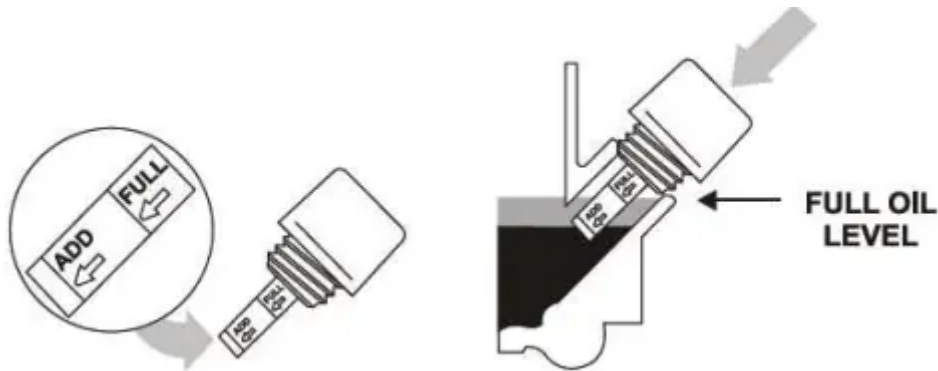

5. If needed, slowly pour oil into oil fill opening to the point of overflowing.
6. Replace and tighten dipstick.

NOTICE Do not attempt to crank or start engine before it has been properly serviced with recommended oil. This could result in an engine failure.

7. Replace cover over oil fill area.

CAUTION Avoid prolonged or repeated skin contact with used motor oil. Used motor oil has been shown to cause skin cancer in certain laboratory animals. Thoroughly wash exposed areas with soap and water.



KEEP OUT OF REACH OF CHILDREN. DON'T POLLUTE. CONSERVE RESOURCES.
RETURN USED OIL TO COLLECTION CENTERS.

Changing Engine Oil

If you are using your generator under extremely dirty or dusty conditions, or in extremely hot weather, change the oil more often.

Change the oil while the engine is still warm from running, as follows:

1. Make sure unit is on a level surface.
2. Remove cover over the oil fill area.
3. Remove oil drain plug and drain oil completely into a suitable container.

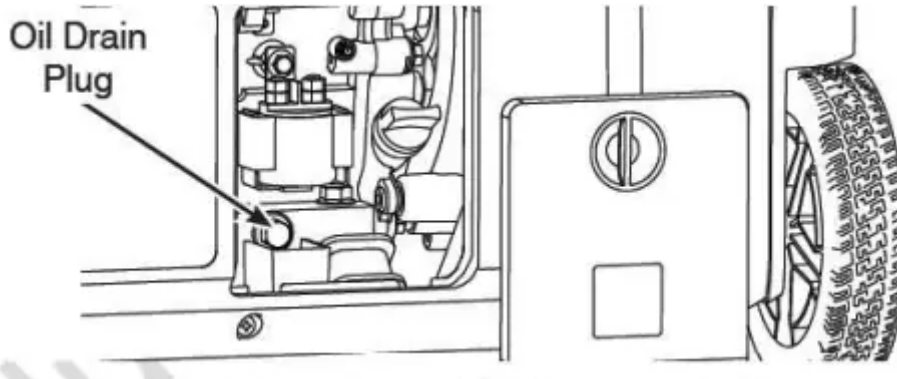

4. Reinstall oil drain plug and tighten securely. Remove dipstick.
5. Slowly pour recommended oil (about 20 oz. (0.6 l)) into oil fill opening. Pause to permit oil to settle. Fill to Full mark on dipstick.
6. Wipe dipstick clean each time oil level is checked. Do not overfill.
7. Reinstall dipstick. Tighten cap securely.
8. Wipe up any spilled oil.
9. Replace cover over oil fill area.

Service Air Cleaner

WARNING! Fuel and its vapors are extremely flammable which could cause burns or fire resulting in death or serious injury.

Do not start and run engine with air filter removed.

Your engine will not run properly and may be damaged if you run it with a dirty air filter. Clean or replace more often if operating under dusty or dirty conditions.

NOTICE Do not use pressurized air to clean the filter. Pressurized air can damage the filter.

To service the air cleaner, follow these steps:

1. Loosen the two maintenance cover screws and remove the maintenance cover.

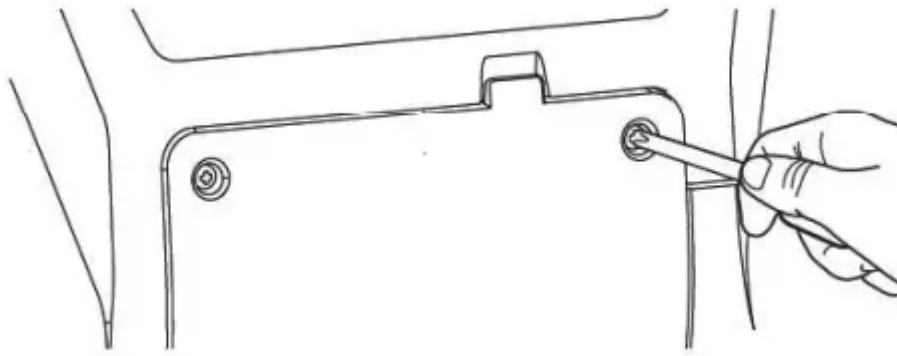

2. Remove three air cleaner cover screws and slide air cleaner assembly out.

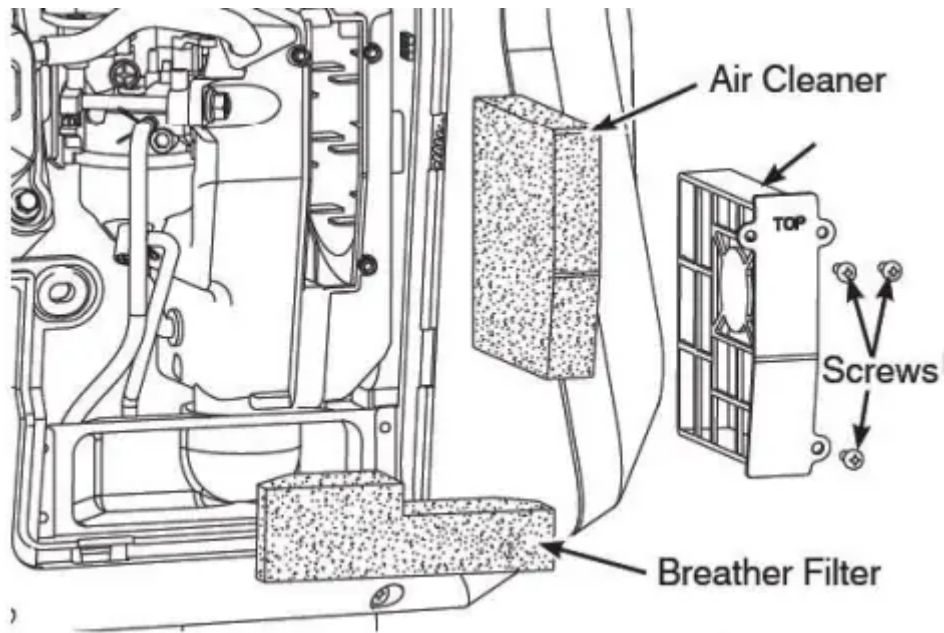

3. Carefully remove foam air cleaner from the assembly.

4. Carefully remove breather filter from the base by pulling it out towards you.

5. Wash foam air cleaner and breather filter in liquid detergent and water only. Squeeze dry in a clean cloth.

6. SATURATE foam air cleaner in clean engine oil and squeeze in a clean cloth to remove excess oil.

7. Reinstall clean or new foam air cleaner inside assembly.

8. Reinstall clean or new breather filter inside base.

9. Slide air cleaner assembly into base and tighten screws.

10. Reinstall the maintenance cover and hand tighten the cover screws.

Service Spark Plug

Changing the spark plug will help your engine to start easier and run better.

1. Loosen the two maintenance cover screws and remove the maintenance cover.

2. Clean area around spark plug and remove spark plug boot.

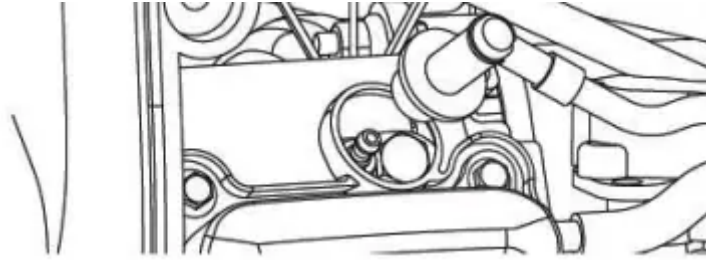

3. Remove spark plug and inspect spark plug.
4. Replace spark plug if electrodes are pitted, burned or porcelain is cracked. Use the recommended replacement spark plug. See Common Service Parts.
5. Check electrode gap with wire feeler gauge and reset spark plug gap to recommended gap if necessary (see Specifications).

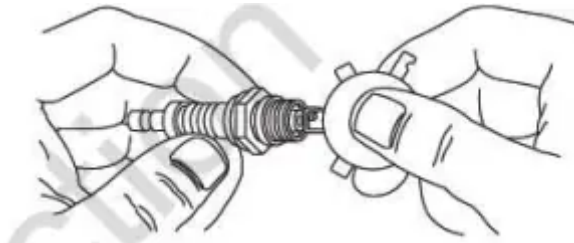

6. Install spark plug and tighten firmly. Reinstall spark plug boot.
7. Reinstall maintenance cover and hand tighten screws.

Inspect Spark Arrester

Inspect spark arrester for damage or carbon blockage. If damage is found or cleaning is needed, see a Briggs & Stratton Authorized Service Dealer.

WARNING! Contact with muffler area could cause burns resulting in serious injury.

- Do not touch hot parts.
- It is a violation of California Public Resource Code, Section 4442, to use or operate the engine on any forest-covered, brush-covered, or grass-covered land unless the exhaust system is equipped with a spark arrester, as defined in Section 4442, maintained in effective working order. Other states or federal jurisdictions may have similar laws, reference Federal Regulation 36 CFR Part 261.52.

Storage

If storing the unit for more than 30 days, use the following guidelines to prepare it for storage.

Long Term Storage Instructions

1. Clean the generator as outlined in *Cleaning*.

2. Change engine oil while engine is still warm, drain oil from crankcase. Refill with recommended grade. See *Changing Engine Oil*.
3. Treat or drain fuel from generator as fuel can become stale when stored over 30 days.

Each time you fill the container with fuel, add STA-BIL 360° PROTECTION^M to the fuel as specified by the manufacturer's instructions. This keeps fuel fresh and decreases fuel-related problems or contamination in the fuel system.

It is not necessary to drain fuel from the engine when STA-BIL 360° PROTECTION is added as instructed. Before storage, turn the engine ON for 2 minutes to move the fuel and stabilizer through the fuel system.

If fuel in the engine has not been treated with STABIL 360° PROTECTION, it must be drained into an approved container. Then run the engine until it stops from back of fuel.

WARNING! Fuel and its vapors are extremely flammable and explosive which could cause burns, fire or explosion resulting in death or serious injury.

- When storing fuel or equipment with fuel in tank, store away from furnaces, stoves, water heaters, clothes dryers or other appliances that have pilot light or other ignition source because they could ignite fuel vapors.
- When draining fuel, turn generator engine off and let it cool at least 2 minutes before removing fuel cap. Loosen cap slowly to relieve pressure in tank. Drain fuel tank outdoors. Keep fuel away from sparks, open flames, pilot lights, heat, and other ignition sources.
- Check fuel lines, tank, cap and fittings frequently for cracks or leaks. Replace if necessary.

4. Charge battery as outlined in *Battery Maintenance*.

5. Store generator in clean, dry area and cover with a suitable protective cover that does not retain moisture.

WARNING! Storage covers could cause a fire resulting in death or serious injury.

- Do not place a storage cover over a hot or running generator. Let equipment cool for a sufficient time before placing the cover on the equipment.

Troubleshooting



Problem	Cause	Correction
<p>Engine is running, but no AC output is available.</p>	<ol style="list-style-type: none"> 1. One of the circuit breakers is open. 2. Poor connection or defective cord set. 3. Connected device is bad. 4. Red LED light is steady. Generator is overloaded or overheated. 	<ol style="list-style-type: none"> 1. Reset circuit breaker. 2. Check and repair. 3. Connect another device that is in good condition. 4. See <i>Generator Capacity</i>. Press Main Reset button on control panel.
<p>Engine runs well at no-load but “bogs down” when loads are connected.</p>	<ol style="list-style-type: none"> 1. Generator is overloaded. 	<ol style="list-style-type: none"> 1. See <i>Generator Capacity</i>.
<p>Engine will not start; starts and runs rough or shuts down when running.</p>	<ol style="list-style-type: none"> 1. Starting dial is in off position. 2. Low oil indicator light comes on. Low oil level. 3. Dirty air cleaner. 4. Out of fuel. 5. Spark plug wire not connected to spark plug. 6. Flooded with fuel. 	<ol style="list-style-type: none"> 1. Turn starting dial to run position. 2. Fill crankcase to proper level or place generator on level surface. 3. Clean or replace air cleaner. 4. Fill fuel tank. 5. Connect wire to spark plug. 6. Wait 5 minutes and re-crank engine.
<p>Engine shuts down and CO shutdown LED blinks red (••••).</p>	<ol style="list-style-type: none"> 1. Generator improperly located. 	<ol style="list-style-type: none"> 1. Move generator to an open, outdoor area. Air out premises (e.g. open windows and doors) before reoccupying. See



		<i>Carbon Monoxide (CO) Shutdown System.</i>
--	--	--

For all other issues, see a Briggs & Stratton authorized dealer.

Warning

This content is compiled from multiple sources and is provided for reference purposes only. It may not be complete or fully applicable to all situations. If you are unable to resolve your issue, please contact the product manufacturer or an authorized service provider for official support.

Document generated by [ManualsFile](#)

