

## USE AND CARE

### LP Cylinder Removal, Transport and Storage

- Turn OFF all control knobs and LP cylinder valve. Turn coupling nut counterclockwise by hand only - do not use tools to disconnect. Loosen cylinder screw beneath bottom shelf or disconnect other retention means, then lift LP cylinder up and out of cart. Install safety cap onto LP cylinder valve. Always use cap and strap supplied with valve. Failure to use safety cap as directed may result in serious personal injury and/or property damage.
- A disconnected LP cylinder in storage or being transported must have a safety cap installed (as shown). Do not store an LP cylinder in enclosed spaces such as a carport, garage, porch, covered patio or other building. Never leave an LP cylinder inside a vehicle which may become overheated by the sun.
- Do not store an LP cylinder in an area where children play.

### LP Cylinder Valve

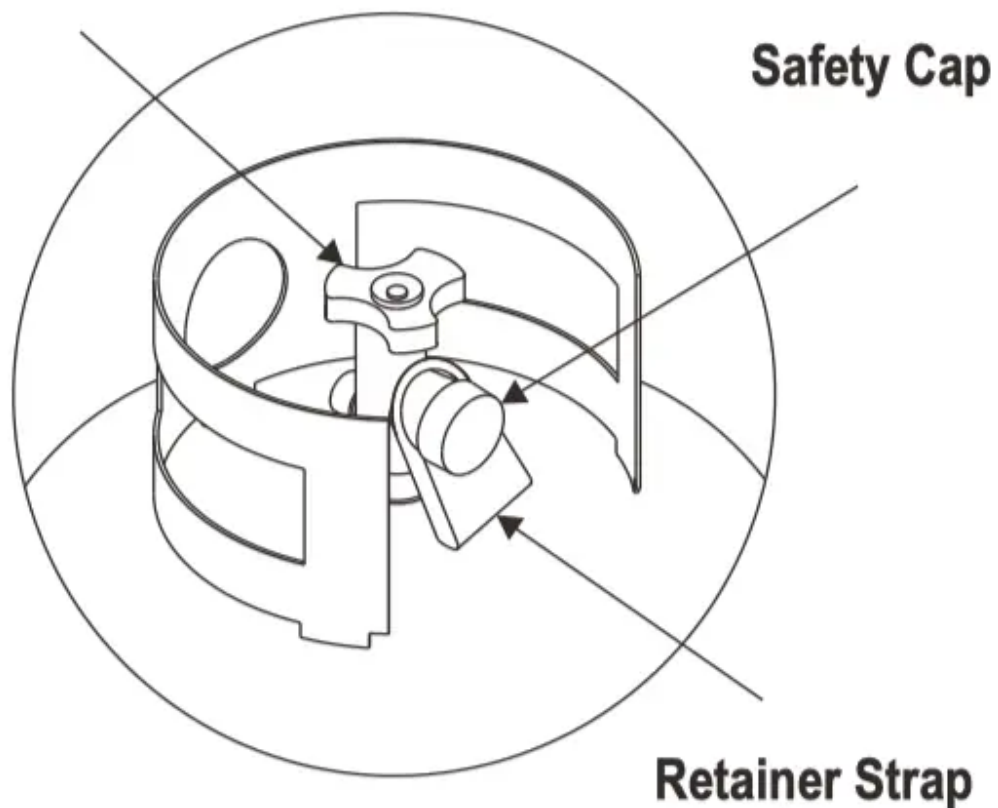

## LP Cylinder

- The LP cylinder used with your grill must meet the following requirements:
- Use LP cylinders only with these required measurements: 12" (30.5cm) (diameter) x 18" (45.7 cm) (tall) with 20 lb. (9 kg.) capacity maximum.
- LP cylinders must be constructed and marked in accordance with specifications for LP cylinders of the U.S. Department of Transportation (DOT) or for Canada, CAN/CSA-B339, cylinders, spheres and tubes for transportation of dangerous goods, Transport Canada (TC). See LP cylinder collar for marking.
- LP cylinder valve must have:
- Type 1 outlet compatible with regulator or grill.
- Safety relief valve.
- UL listed Overfill Protection Device (OPD). This OPD safety feature is identified by a unique triangular hand wheel. Use only LP cylinders equipped with this type of valve.



**OPD Hand Wheel**

- LP cylinder must be upright for vapor withdrawal and include collar to protect LP cylinder valve. Always keep LP cylinders in upright position during use, transit or storage.

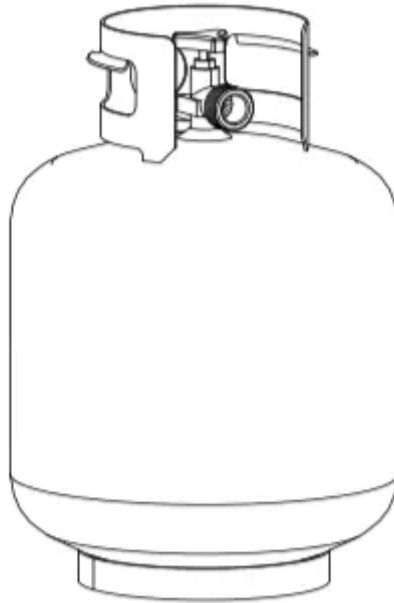

*LP cylinder in upright position for vapor withdrawal*

## **LP (Liquefied Petroleum Gas)**

- LP gas is nontoxic, odorless and colorless when produced. For Your Safety, LP gas has been given an odor (similar to rotten cabbage) so that it can be smelled.
- LP gas is highly flammable and may ignite unexpectedly when mixed with air.

## **LP Cylinder Filling**

- Use only licensed and experienced dealers.
- LP dealer must purge new cylinder before filling.
- Dealer should NEVER fill LP cylinder more than 80% of LP cylinder volume. Volume of propane in cylinder will vary by temperature.
- A frosty regulator indicates gas overfill. Immediately close LP cylinder valve and call local LP gas dealer for assistance.
- Do not release liquid propane (LP) gas into the atmosphere. This is a hazardous practice.
- To remove gas from LP cylinder, contact an LP dealer or call a local fire department for assistance. Check the telephone directory under “Gas Companies” for nearest certified LP dealers.

## **LP Cylinder Exchange**

- Many retailers that sell grills offer you the option of replacing your empty LP cylinder through an exchange service. Use only those reputable exchange companies that inspect,

precision fill, test and certify their cylinders. Exchange your cylinder only for an OPD safety feature-equipped cylinder as described in the "LP Cylinder" section of this manual.

- Always keep new and exchanged LP cylinders in upright position during use, transit or storage.
- Leak test new and exchanged LP cylinders BEFORE connecting to grill.
- Place safety cap on cylinder valve outlet whenever the cylinder is not in use. Only install the type of safety cap on the cylinder valve outlet that is provided with the cylinder valve. Other types of caps or plugs may result in leakage of propane.

## LP Cylinder Leak Test

### For your safety

- Leak test must be repeated each time LP cylinder is exchanged or refilled.
- Do not smoke during leak test.
- Do not use an open flame to check for gas leaks.
- Grill must be leak tested outdoors in a well-ventilated area, away from ignition sources such as gas fired or electrical appliances. During leak test, keep grill away from open flames or sparks.
- Use a clean paintbrush and a 50/50 mild soap and water solution. Brush soapy solution onto areas indicated by arrows in figure below.
- Do not use household cleaning agents. Damage to gas train components can result.

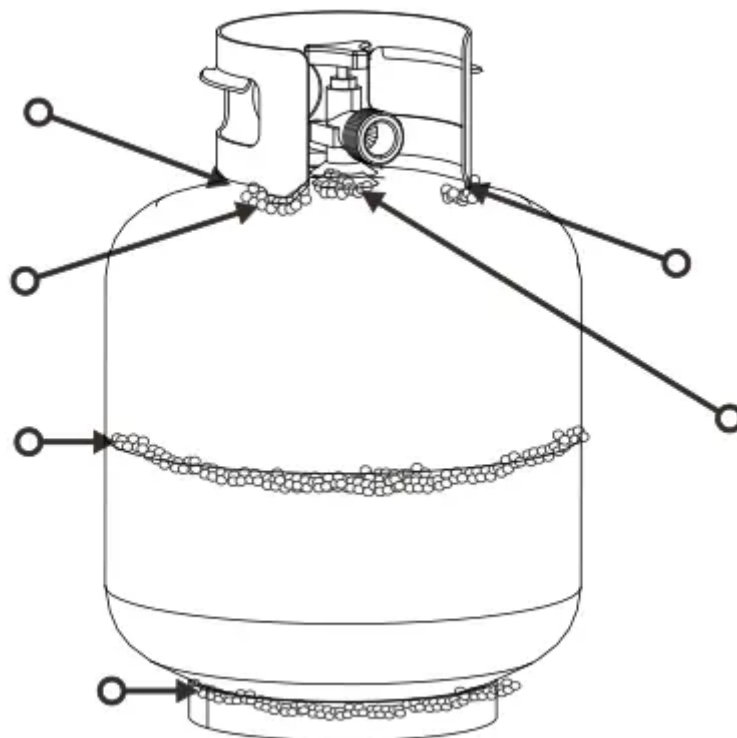

## WARNING

If “growing” bubbles appear, do not use or move the LP cylinder. Contact an LP gas supplier or your fire department!

### Connecting Regulator to the LP Cylinder

- 1.LP cylinder must be properly secured onto grill. (Refer to assembly section.)
- 2.Turn all control knobs to the OFF position.
- 3.Turn LP cylinder OFF by turning hand-wheel clockwise to a full stop.
- 4.Remove the safety cap from LP cylinder valve. Always use cap and strap if supplied with valve.



**Safety Relief Valve**

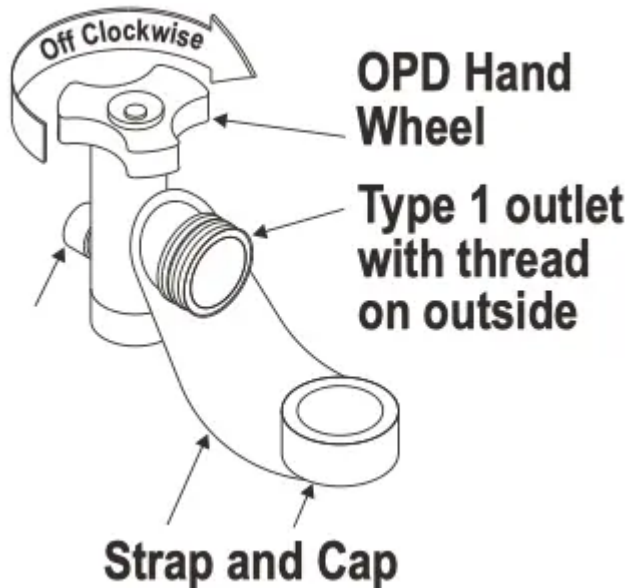

**Do not use a POL transport plug (plastic part with external threads)! It will defeat the safety feature of the valve.**

- 5.Hold regulator and insert nipple into LP cylinder valve. Hand-tighten the coupling nut, holding regulator in a straight line with LP cylinder valve so as not to cross-thread the connection.

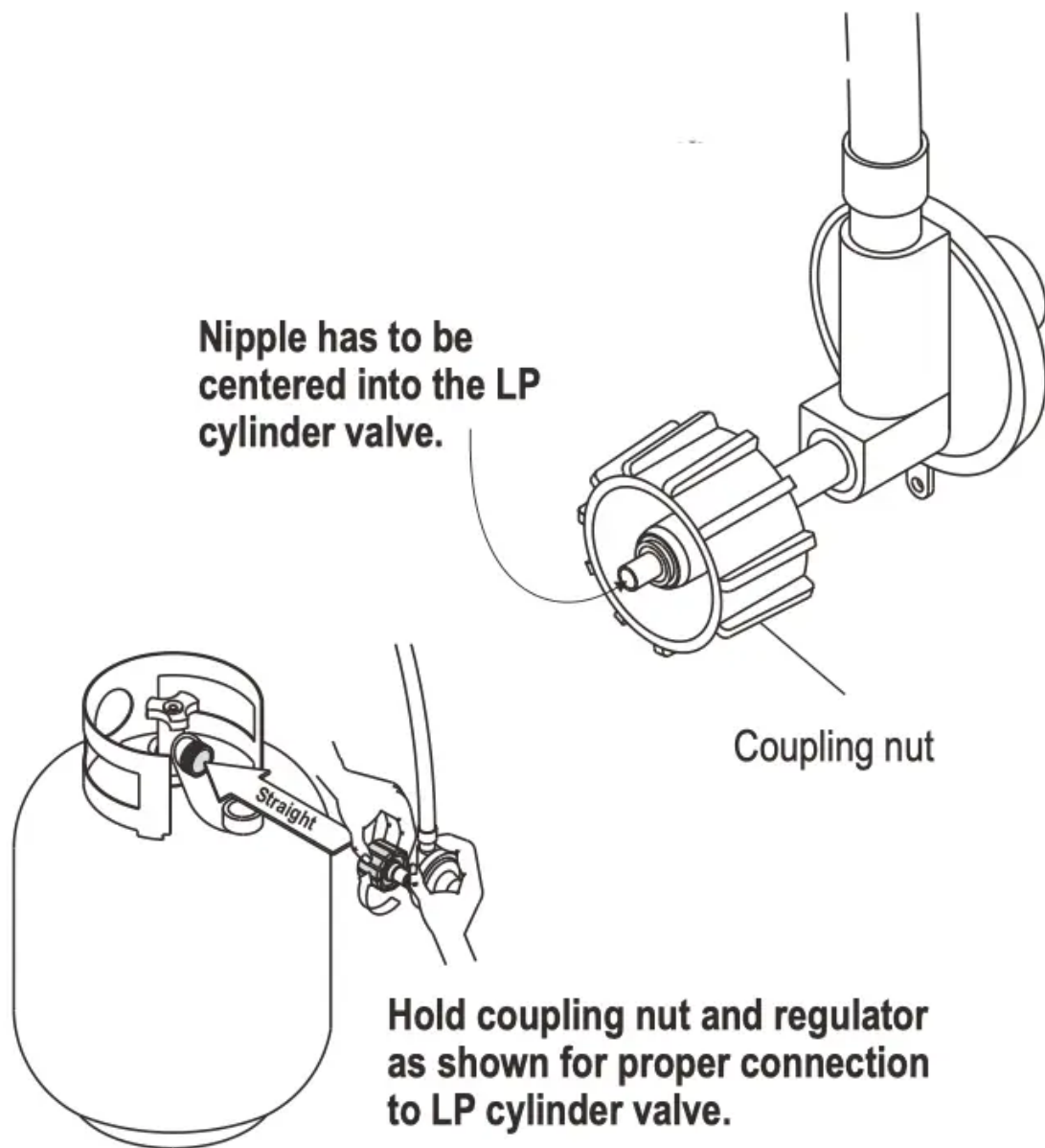

6. Turn the coupling nut clockwise and tighten to a full stop. The regulator will seal on the back-check feature in the LP cylinder valve, resulting in some resistance. An additional one-half to three-quarters turn is required to complete the connection. Tighten by hand only – do not use tools.

**NOTE:**

If you cannot complete the connection, disconnect regulator and repeat steps 5 and 6. If you are still unable to complete the connection, do not use this regulator!

**DANGER**

- Do not insert any tool or foreign object into the valve outlet or safety relief valve. You may damage the valve and cause a leak. Leaking propane may result in explosion, fire, severe personal injury, or death.

**WARNING**

- Do not use grill until leak-tested.
- If a leak is detected at any time, STOP! Turn off gas at source and correct leak.
- If you cannot stop a gas leak by closing the LP cylinder valve leave area and call your fire department!

### **Leak Testing Valves, Hose and Regulator**

1. Turn all grill control knobs to OFF.
2. Be sure regulator is tightly connected to LP cylinder.
3. Completely open LP cylinder valve by turning hand wheel counterclockwise. If you hear a rushing sound, turn gas off immediately. There is a major leak at the connection. Correct before proceeding.
4. Brush soapy solution onto areas circled below, or other similar fittings on your grill.

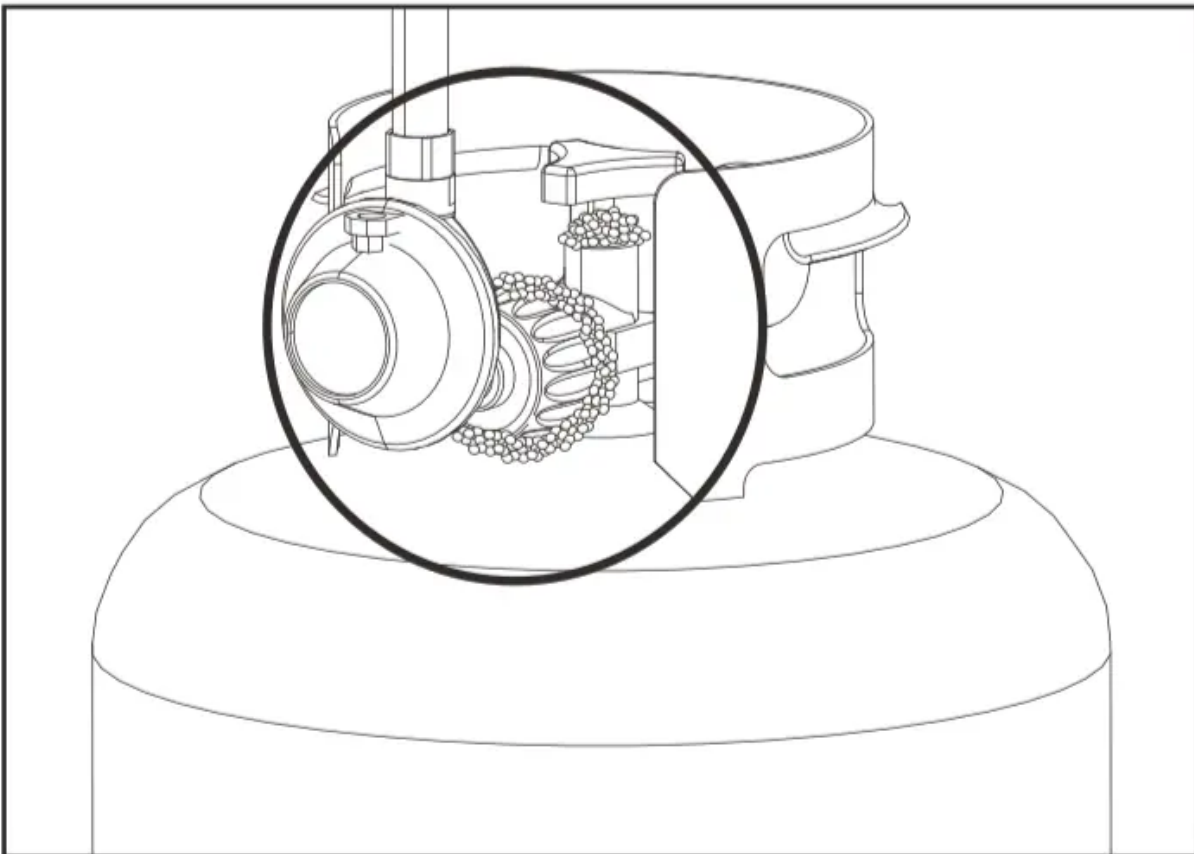

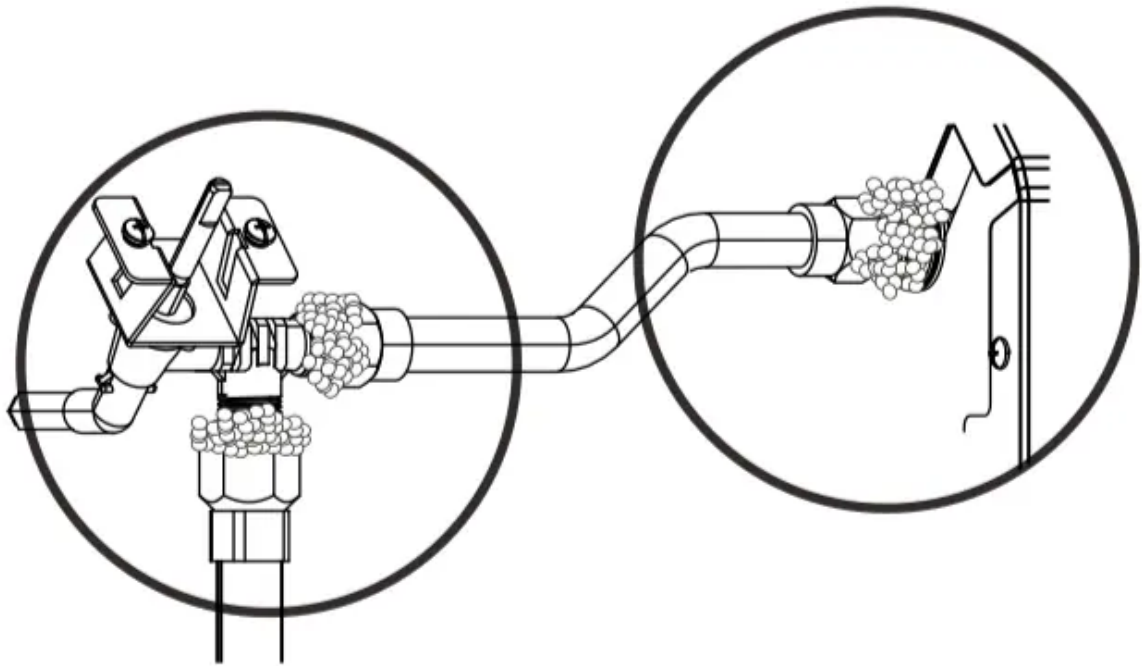

**NOTE:** Sideburner shelf fascia and other parts not shown for clarity.

**NOTE:** Your grill may NOT be equipped with a sideburner.

5.If “growing” bubbles appear, there is a leak. Close LP cylinder valve immediately and retighten connections. If leaks cannot be stopped do not try to repair. Call for replacement parts.

6.Always close LP cylinder valve after performing leak test by turning hand wheel clockwise.

### **WARNING**

- Outdoor gas appliance is not intended to be installed in or on a boat.
- Outdoor gas appliance is not intended to be installed in or on an RV.
- Never attempt to attach this grill to the self-contained LP gas system of a camper trailer or motor home.

### **Safety Tips**

- Before opening LP cylinder valve, check the coupling nut for tightness.
- When grill is not in use, turn off all control knobs and LP cylinder valve.
- Never move grill while in operation or still hot.
- Some surfaces will be hot during use. Use long-handled barbecue utensils and oven mitts to avoid burns and splatters.
- Maximum load for sideburner and side shelf is 10 lbs.
- The grease tray or cup must be installed during use and emptied after each use. Do not remove grease tray or cup until grill has completely cooled.

- Clean grill often, preferably after each cookout. If a bristle brush is used to clean any of the grill cooking surfaces, ensure no loose bristles remain on cooking surfaces prior to grilling. It is not recommended to clean cooking surfaces while grill is hot.
- If you notice grease or other hot material dripping from grill onto valve, hose or regulator, turn off gas supply at once. Determine the cause, correct it, then clean and inspect valve, hose and regulator before continuing. Perform a leak test.
- Keep ventilation openings in cylinder enclosure (grill cart) free and clear of debris.
- Do not store objects or materials inside the grill cart enclosure that would block the flow of combustion air to the underside of either the control panel or the firebox bowl.
- The regulator may make a humming or whistling noise during operation. This will not affect safety or use of grill.
- If you have a grill problem see the "Troubleshooting" Section.
- If the regulator frosts, turn off grill and LP cylinder valve immediately. This indicates a problem with the cylinder and it should not be used on any product. Return to supplier!

**WARNING CHOKING HAZARD**-Small parts. Not for children under 3 years.

### **Battery**

- a. Size of battery/ type/ designation: AAA
- b. Nominal Voltage: 1.5v
- c. Number of battery required: 1PC
- d. Battery included or not: Yes

Non-rechargeable batteries are not to be recharged. Batteries are to be inserted with the correct polarity. Exhausted batteries are to be removed from the product. Do not dispose of the batteries in fire. Batteries may explode or leak.

### **WARNING**

#### **LP GAS CYLINDER RUBBER SEAL INSPECTION.**

- Inspect the LP gas cylinder valve rubber seal for cracks, wear or deterioration prior to each use. A damaged rubber seal can cause a gas leak, possibly resulting in an explosion, fire, or severe bodily harm.
- It is recommended that you inspect the rubber seal each time the LP gas cylinder is connected to the appliance, each time it has been refilled, or if it has not been used for more than 60 days.
- DO NOT use a LP gas cylinder with a damaged rubber seal. The rubber seal CANNOT be repaired or replaced. Purchase a new cylinder or exchange the cylinder. You should inspect the seal before accepting a new or exchanged cylinder. DO NOT insert tools or foreign objects into the cylinder valve opening as this could damage the rubber seal.

- The leak check procedure outlined in the product guide/assembly manual **MUST** be followed each time the LP gas cylinder is connected to the appliance. Consult the product guide/assembly manual for the proper procedure and locations for leak checking.

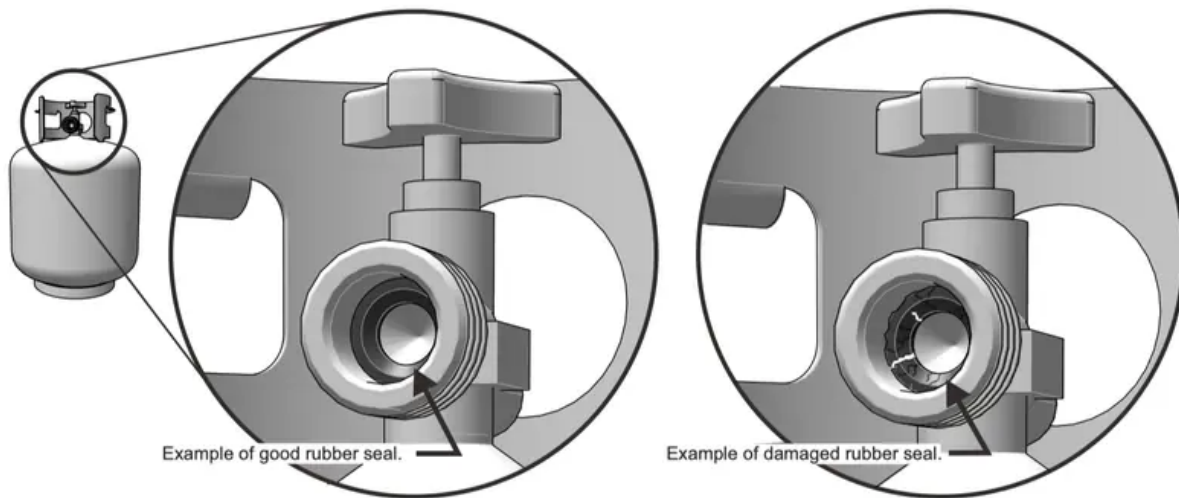

## WARNING

### For Safe Use of Your Grill and to Avoid Serious Injury:

- Do not let children operate or play near grill.
- Keep grill area clear and free from materials that burn.
- Do not block holes in sides or back of grill.
- Check burner flames regularly.
- Use grill only in well-ventilated space. **NEVER** use in enclosed space such as carport, garage, porch, covered patio, or under an overhead structure of any kind.
- Do not use charcoal or ceramic briquets in a gas grill.
- Do not cover grates with aluminum foil or any other material. This will block burner ventilation and create a potentially dangerous condition resulting in property damage and/or personal injury.
- Use grill at least 3 ft. from any wall or surface. Maintain 10 ft. clearance to objects that can catch fire or sources of ignition such as pilot lights on water heaters, live electrical appliances, etc.

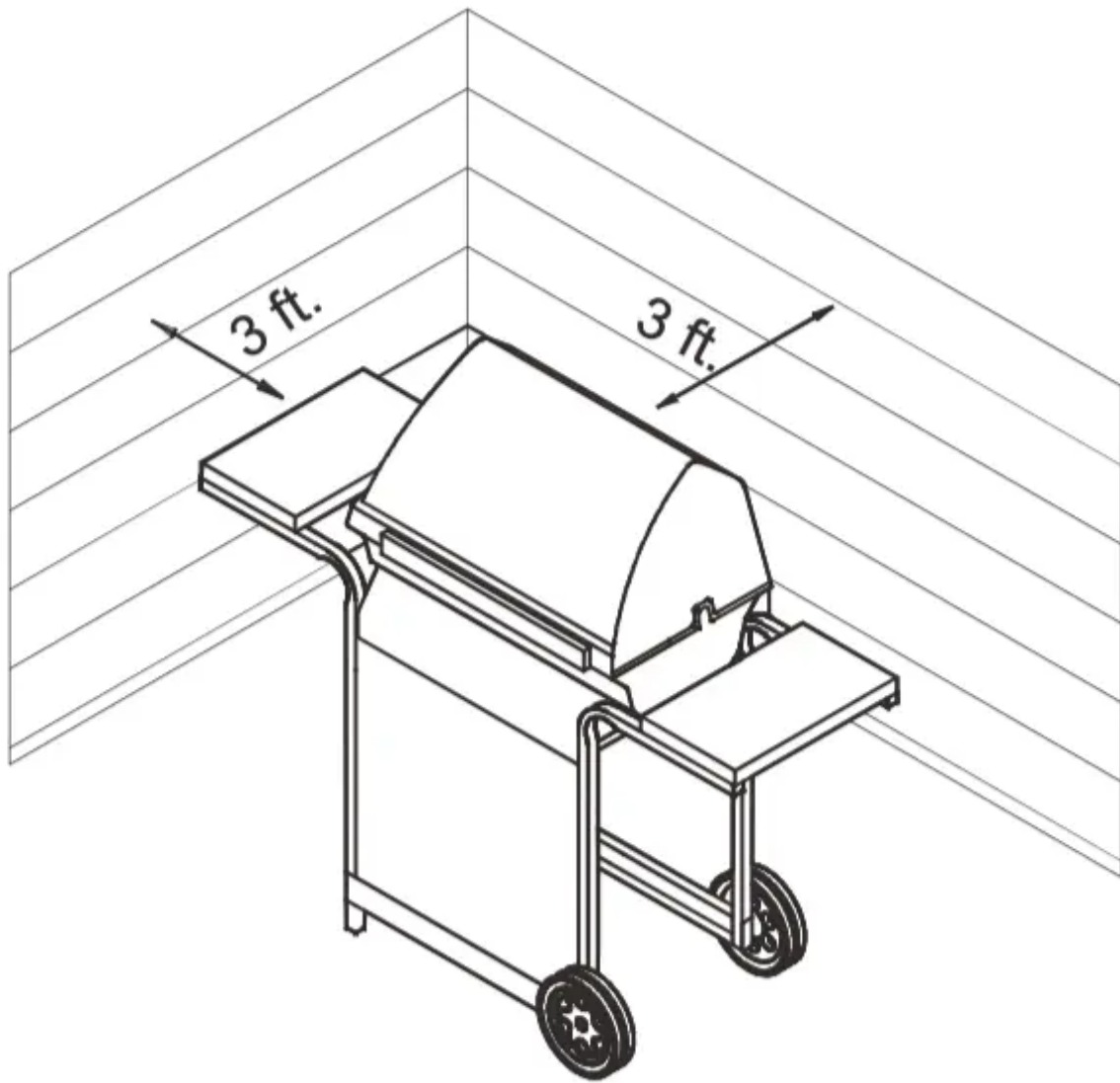

- NEVER attempt to light or re-light burner with lid closed. A buildup of non-ignited gas inside a closed grill is hazardous.
- Never operate grill with LP cylinder out of correct position specified in assembly instructions.
- Always close LP cylinder valve and remove coupling nut before moving LP cylinder from specified operation position.
- Apartment Dwellers:

Check with management to learn the requirements and fire codes for using an LP gas grill in your apartment complex. If allowed, use outside on the ground floor with a three (3) foot clearance from walls or rails. Do not use on or under balconies.

## Ignitor Lighting

- **Do not lean over grill while lighting.**

1. Turn gas burner control valves to  (off).

2. Open lid during lighting or re-lighting.

3. Turn ON gas at LP cylinder.

4. To ignite, push and turn IGNITION BURNER knob to  HIGH. Immediately, push and hold ELECTRONIC IGNITOR button until the burner lights.

5. If ignition does NOT occur in 5 seconds, turn the burner controls off , wait 5 minutes and repeat the lighting procedure.

6. To ignite remaining burners, push and turn knob to the  HIGH position starting with the burners closest to the IGNITION BURNER first.

### **WARNING**

Turn controls and gas source or tank OFF when not in use.

### **CAUTION**

If ignition does NOT occur in 5 seconds, turn the burner controls  off, wait 5 minutes and repeat the lighting procedure. If the burner does not ignite with the valve open, gas will continue to flow out of the burner and could accidentally ignite with risk of injury.

### **Match-Lighting**

- **Do not lean over grill while lighting.**

1. Turn gas burner control valves to  (off).

2. Open lid during lighting or re-lighting.

3. Turn ON gas at LP cylinder.

4. Place match into match holder (hanging from side panel of grill). Light match; then light burner by placing match through the match light hole on side of grill. Immediately push in and turn burner knob to the  HIGH position. Be sure burner lights and stays lit.

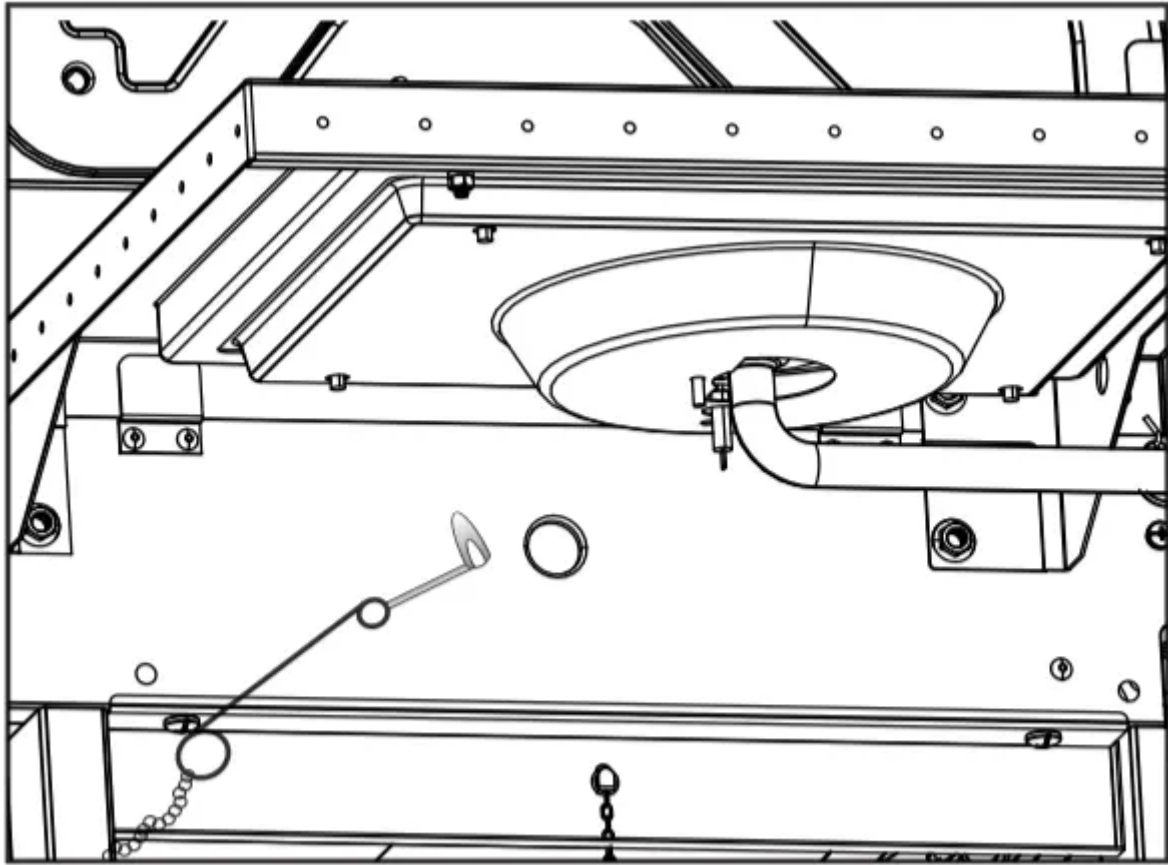

5. Light adjacent burners in sequence by pushing knobs in and turning to the  HIGH position.



**NOTE:** Your grill may NOT be equipped with a Sideburner!

### Sideburner Ignitor Lighting

- **Do not lean over grill while lighting.**

1. Turn gas burner control valves to  (off).
2. Open lid during lighting or re-lighting.
3. Turn ON gas at LP cylinder.
4. Turn sideburner knob to the  HIGH position, push and hold ELECTRONIC IGNITOR button.
5. If sideburner does NOT light within 5 seconds, turn knob to  off, wait 5 minutes, then repeat lighting procedure.

### Sideburner Match Lighting

- **Do not lean over grill while lighting.**

1. Turn gas burner control valves to  (off).
2. Open lid during lighting or re-lighting.

3. Turn ON gas at LP cylinder.

4. Place lit match near burner. Immediately turn sideburner knob to the  HIGH position. Be sure burner lights and stays lit.

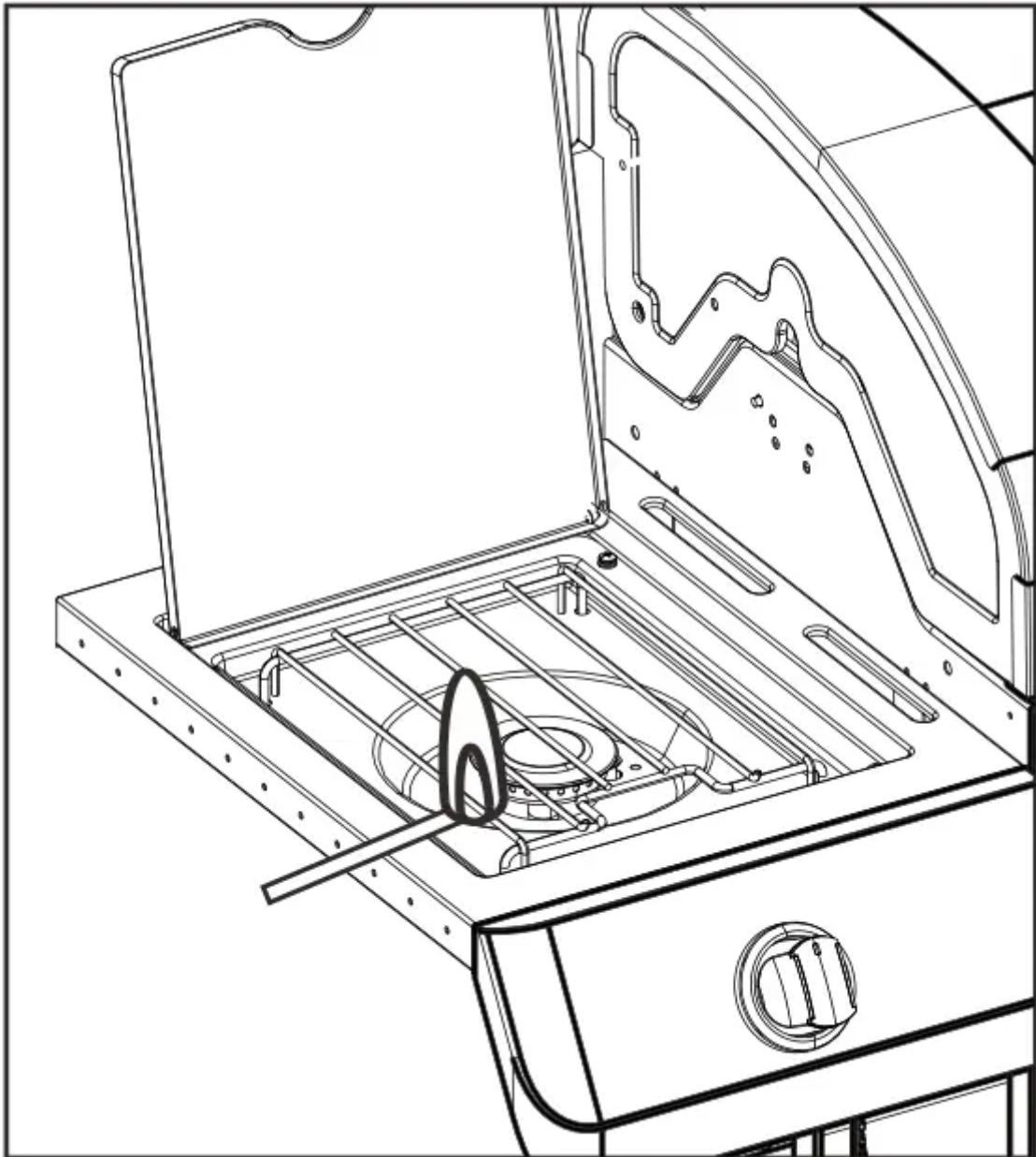

### CAUTION

- Putting out grease fires by closing the lid is not possible. Grills are well ventilated for safety reasons.
- Do not use water on a grease fire. Personal injury may result. If a grease fire develops, turn knobs and LP cylinder off.
- Do not leave grill unattended while preheating or burning off food residue on HI. If grill has not been regularly cleaned, a grease fire can occur that may damage the product.

## Burner Flame Check

- Remove cooking grates and heat tents. Light burners, rotate knobs from HIGH to LOW. You should see a smaller flame in LOW position than seen on HIGH. Perform burner flame check on side burner, also. Always check flame prior to each use. If only low flame is seen refer to "Sudden drop or low flame" in the Troubleshooting Section.

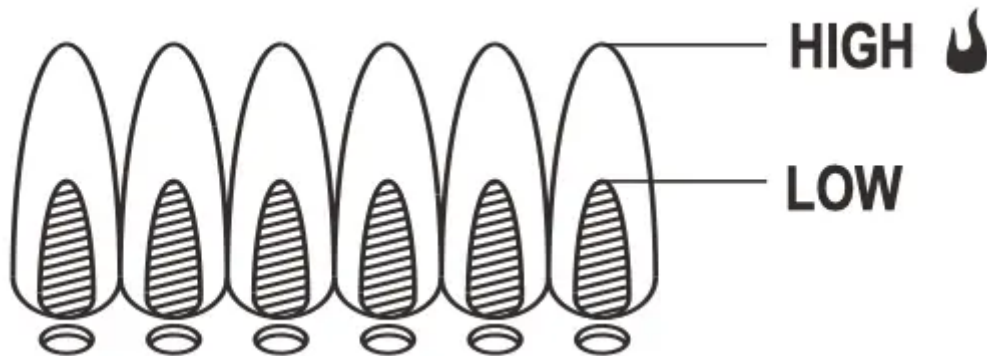

## Turning Grill Off

- Turn all knobs to the off position. Turn LP cylinder off by turning hand-wheel clockwise to a full stop.

## Ignitor Check

- Turn gas off at LP cylinder. Press and hold electronic ignitor button. "Click" should be heard and spark seen each time in each collector box or between burner and electrode. See "Troubleshooting" if no click or spark.

## Valve Check

- **Important:** Make sure gas is off at LP cylinder before checking valves. Knobs lock in off position. To check valves, first push in knobs and release, knobs should spring back. If knobs do not spring back, replace valve assembly before using grill. Turn knobs to LOW position then turn back to off position. Valves should turn smoothly.

## Hose Check

- Before each use, check to see if hoses are cut or worn or kinked. Replace damaged hoses before using grill. Use only valve/hose/regulator specified by manufacturer.

## Storing Your Grill

- Clean cooking grates.
- Store in dry location.

- When LP cylinder is connected to grill, store outdoors in a well-ventilated space and out of reach of children.
- Cover grill if stored outdoors. Choose from a variety of grill covers offered by Char-Broil at [charbroil.com](http://charbroil.com).
- Store grill indoors ONLY if LP cylinder is turned off and disconnected, removed from grill and stored outdoors.
- When removing grill from storage, follow “Cleaning the Burner Assembly” instructions before starting grill.

## CAUTION

### SPIDER ALERT!

# SPIDER AND WEBS INSIDE BURNER

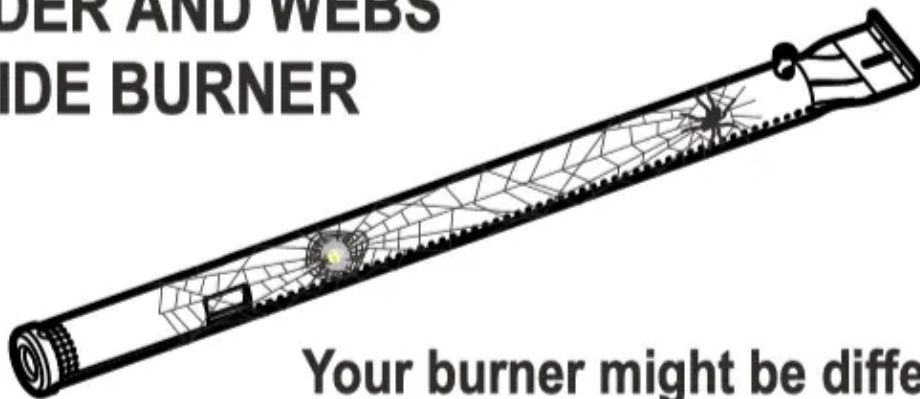

**Your burner might be different**

If your grill is getting hard to light or the flame is weak, check and clean the venturis and burners.

Spiders or small insects are known to create “flashback” problems by building nests and laying eggs in the grill’s venturi or burner, obstructing the flow of gas. The backup gas can ignite behind the control panel. This flashback can damage your grill and cause injury. To prevent flashbacks and ensure good performance the burner and venturi tube assembly should be removed and cleaned when ever the grill has been idle for an extended period of time.

## General Grill Cleaning

- Do not mistake brown or black accumulation of grease and smoke for paint. Interiors of gas grills are not painted at the factory (and should never be painted). Apply a strong solution of detergent and water or use a grill cleaner with scrub brush on insides of grill lid and bottom. Rinse and allow to completely air dry. Do not apply a caustic grill/oven cleaner to painted surfaces.
- Plastic parts: Wash with warm soapy water and wipe dry.

- Do not use citrisol, abrasive cleaners, degreasers or a concentrated grill cleaner on plastic parts. Damage to and failure of parts can result.
- Porcelain surfaces: Because of glass-like composition, most residue can be wiped away with baking soda/water solution or specially formulated cleaner. Use nonabrasive scouring powder for stubborn stains.
- Painted surfaces: Wash with mild detergent or nonabrasive cleaner and warm soapy water. Wipe dry with a soft nonabrasive cloth.
- Stainless steel surfaces: To maintain your grill's high quality appearance, wash with mild detergent and warm soapy water and wipe dry with a soft cloth after each use. Baked-on grease deposits may require the use of an abrasive plastic cleaning pad. Use only in direction of brushed finish to avoid damage. Do not use abrasive pad on areas with graphics.
- Cooking surfaces: If a bristle brush is used to clean any of the grill cooking surfaces, ensure no loose bristles remain on cooking surfaces prior to grilling. It is NOT recommended to clean cooking surfaces while grill is hot.

## Cleaning the Burner Assembly

Follow these instructions to clean and/or replace parts of burner assembly or if you have trouble igniting grill.

1. Turn gas off at control knobs and LP cylinder.
2. Remove cooking grates and heat tents.
3. Remove carryover tubes and hardware securing burners.
4. Detach electrode from burner.

**NOTE:** Removal/Detachment method will depend on the burner configuration. See different configurations in illustrations below.

5. Carefully lift each burner up and away from valve openings.

We suggest three ways to clean the burner tubes. Use the one easiest for you.

(A) Bend a stiff wire (a light weight coat hanger works well) into a small hook. Run the hook through each burner tube several times.



(B) Use a narrow bottle brush with a flexible handle (do not use a brass wire brush). Run the brush through each burner tube several times.

(C) Wear eye protection: Use an air hose to force air into the burner tube and out the burner ports. Check each port to make sure air comes out each hole.

6. Wire brush entire outer surface of burner to remove food residue and dirt.
7. Clean any blocked ports with a stiff wire such as an open paper clip.
8. Check burner for damage due to normal wear and corrosion, some holes may become enlarged. If any large cracks or holes are found, replace burner.

**VERY IMPORTANT:** Burner tubes must reengage valve openings. See illustrations at right.

**Correct burner-to-valve engagement**

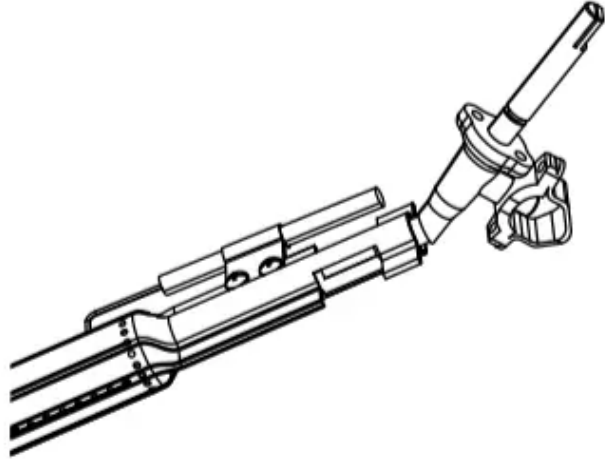

9. Attach electrode to burner.
10. Carefully replace burners.
11. Attach burners to brackets on firebox.
12. Reposition carryover tubes and attach to burners. Replace heat tents and cooking grates.
13. Before cooking again on grill, perform a “Leak Test” and “Burner Flame Check”.

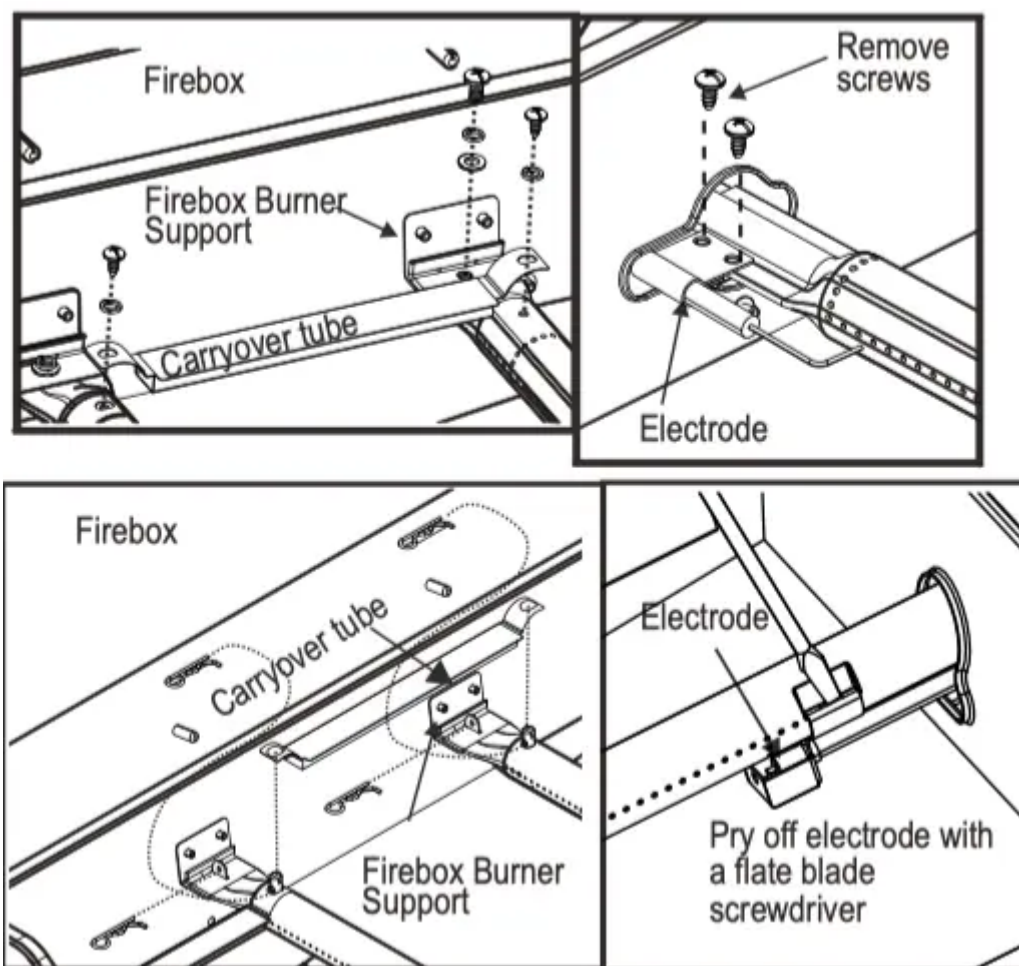

## GRILLING GUIDE – Getting Started

### First Time Use

Read your Assembly Manual and ensure the grill is put together properly. Remove all Point-of-Purchase advertising material from all grill surfaces before first use. We recommend operating your grill on its highest setting for 15-20 minutes prior to your first use. This aids in removing the oils used during manufacturing.

### Lava Rock / Briquettes

This gas grill has been designed, engineered, and tested to be used with heat tents to provide more even heating, improve the cleaning process, and reduce flare-ups. The addition of after market lava rocks, charcoal, or briquettes of any type will cause poor combustion and increase the likelihood of a grease fire, and is not recommended. Using briquettes, lava rock, or charcoal in this grill will void your warranty. For extra smoke flavor, we recommend using a smoker box with wood chips.



## Temperature

The temperature gauge in the hood of your new grill is calibrated to give a close indication of the grate temperature.

**Note:** Since 1995, all regulators (the part that attaches to the gas tank to regulate the flow of gas) have included a safety feature that restricts gas flow in the event of a gas leak. You can inadvertently activate this safety feature without having a gas leak. This typically occurs when you turn on the gas using the grill control knob before you turn on the LP tank valve. If the gas regulator safety feature activates, the grill will only reach temperatures between 250°F and 300°F even with all burners on the high setting.

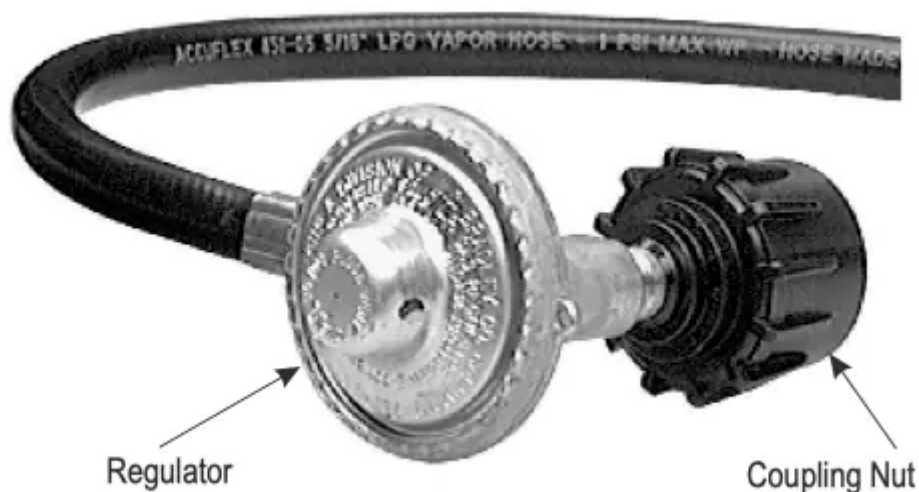

If your grill is not getting hotter than 250°F to 300°F these steps should be taken first to reset the gas regulator safety device:

1. Open the grill lid.

2. Turn off all knobs on the control panel in front.
3. Turn off the tank knob.
4. Disconnect the regulator from the LP tank.
5. Wait 30 seconds.
6. Reconnect the regulator to the LP tank.
7. Slowly open the LP tank knob all the way. Do not put excessive force on the valve at the full open position to avoid damaging the valve.
8. Turn on the appropriate control knob and light the grill per the instructions.

An illustration of this process is included in this Product Guide. See Troubleshooting section for additional information.

## Pre-Heating Your Grill

Just like your home oven, your grill should be pre-heated to provide optimum performance. Pre-heat the grill on high for 10-15 minutes – longer if weather conditions require. Please refer to the lighting instructions inside the Product Guide if you have questions about how to light your grill. A match-light chain and hole is provided for your convenience.

Outdoor grilling is really quite simple. You'll succeed with burgers, dogs, or steaks usually on your very first try. With experience, you will learn how to work with your grill, creating more imaginative meals all the time. This knowledge makes up the art of grilling. Before you start grilling, organize your food according to cooking technique and required cooking time, and optimize the use of your grilling area.

## Direct Cooking

Direct cooking involves grilling your meat directly over high heat. It is perfect for searing steaks, chops, and other smaller pieces of meat and vegetables that quickly make their way to the table.

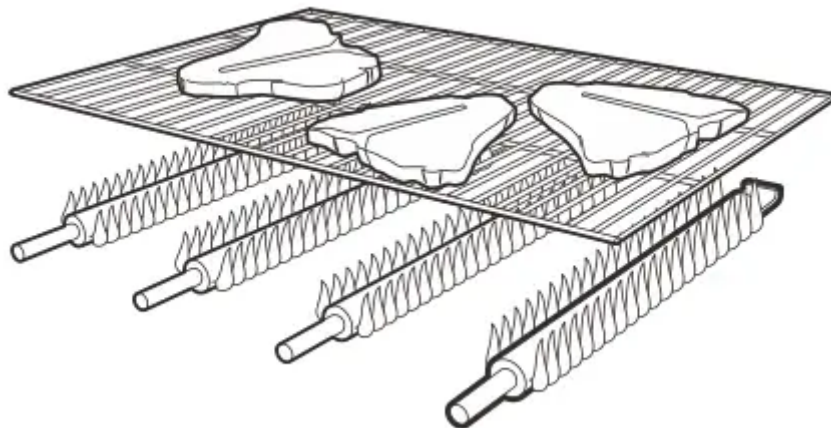

## Indirect Cooking

Indirect cooking utilizes select burners to circulate heat throughout the grill, without direct contact between the meat and the flame. The meat is placed over the burner that is 'off'. This method is generally used to slow cook large cuts of meat and poultry. A pan can be placed underneath the meat to catch grease and food drippings, and helps minimize clean-up.

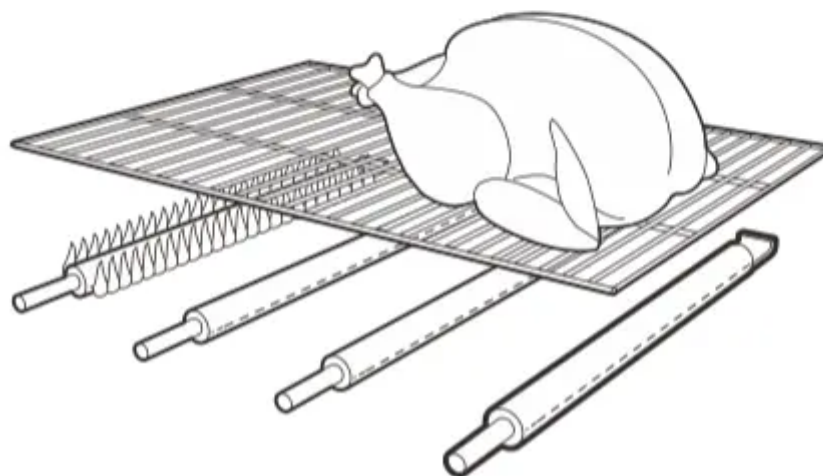
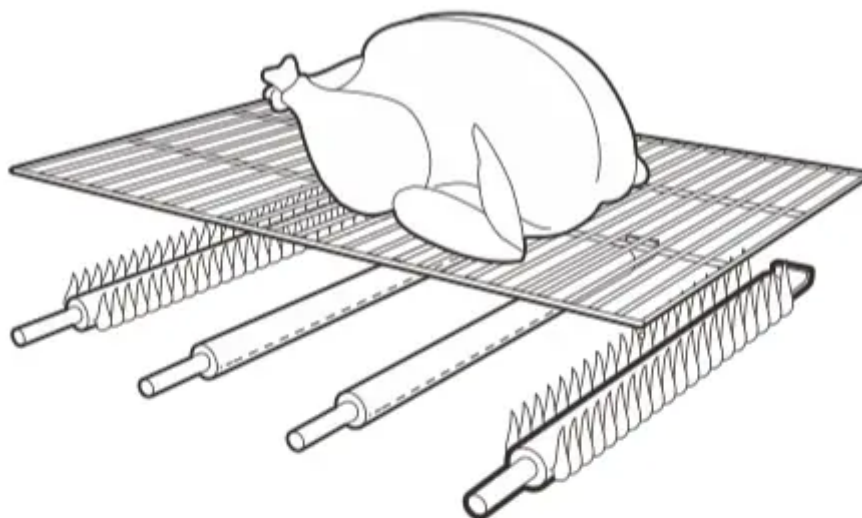

## Rotisserie Cooking

Rotisserie cooking is best for 'round' meat, such as large roasts, whole poultry, and pork. It generally requires an accessory motor and spit rod that allows the meat to be turned at a constant speed. Rotisserie cooking is best done in front of a special rotisserie burner, or utilizing an indirect cooking burner arrangement. A pan can be placed underneath the meat to catch grease and food drippings, and helps minimize clean-up.

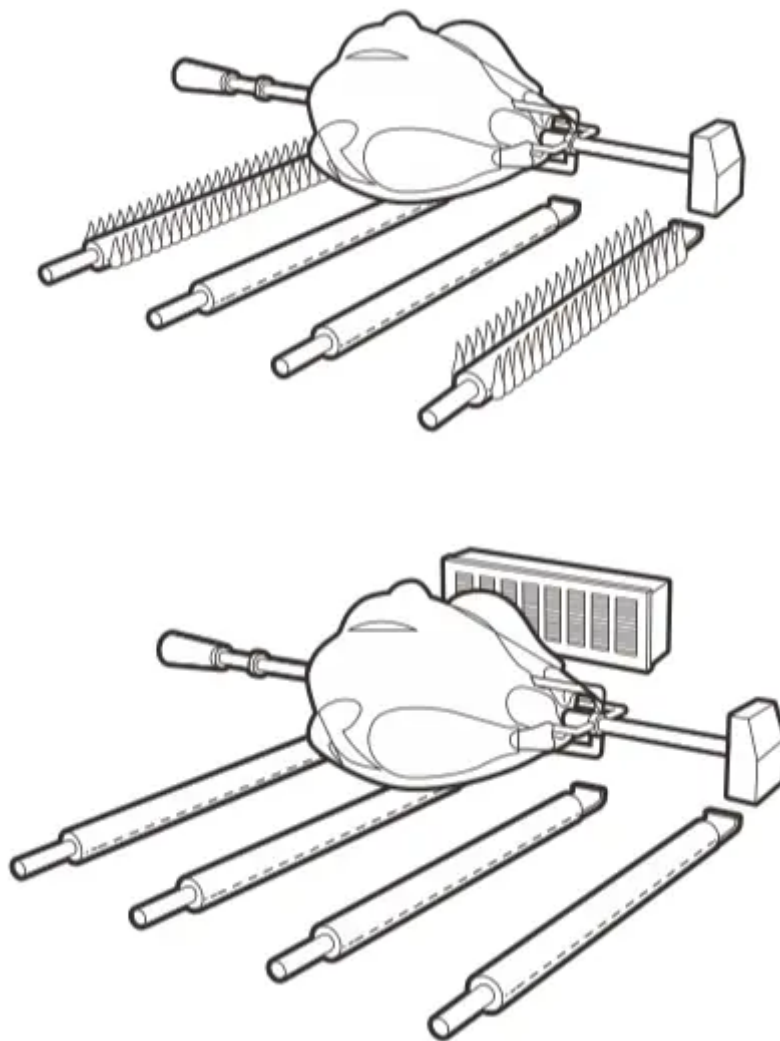

## Food Safety

Food safety is a very important part of enjoying the outdoor cooking experience. To keep food safe from harmful bacteria, follow these four basic steps:

Clean: Wash hands, utensils, and surfaces with hot soapy water before and after handling raw meat.

Separate: Separate raw meats from ready-to-eat foods to avoid cross contamination. Use a clean platter and utensils when removing cooked foods.

Cook: Cook meat and poultry thoroughly to kill bacteria. Use a thermometer to ensure proper internal food temperatures.

Chill: Refrigerate prepared foods and leftovers promptly.

Cooking on your new grill is a hands-on experience, and it is recommended to remain outside with your grill while cooking. Grilling can be affected by many external conditions. In cold weather, you will need more heat to reach an ideal cooking temperature, and grilling may take longer. The meat's internal temperature and thickness can also affect cooking times. Cold and thicker meats will take longer to cook.

## Internal Meat Temperatures

Meat cooked on a grill often browns very fast on the outside. Therefore, use a meat thermometer to ensure it has reached safe internal temperatures.

<b>USDA Recommended Safe Minimum Internal Temperatures</b>	
Beef, Veal, Lamb, Steak, Roasts, & Whole Pork (with a 3 minute rest time)	145° F
Fish	145° F
Beef, Veal, Lamb, and Pork - Ground	160° F
Egg Dishes	160° F
Turkey, Chicken & Duck Whole, Pieces & Ground	165° F

Please refer to the USDA for complete, up-to-date information. Our internal temperature chart is based on USDA standards for meat doneness.

## GRILLING GUIDE – Tips & Tricks

### Sauces

Sauces containing sugars and fats can cause flare-ups, and your food may burn. In general, apply these sauces during the final 5 minutes of cooking. Keep in mind, use of excessive sauces or glazes will also require extra cleaning afterwards.

### Marinades and Rubs

To enhance the flavor of grilled foods, a liquid marinade or dry rub can be used prior to cooking. Meat can be either soaked or injected with liquid marinade up to 24 hours prior to grilling. Dry rubs can be applied directly to the meat immediately before grilling.



## Wood Chips

For extra smoke flavor when grilling, try adding wood chips. Place smoke box or pan on top of the cooking grate above the flame. Turn grill on high until the wood starts to smoke. Reduce heat to desired temperature for cooking, and place food on cooking grate as desired. Close lid to retain more smoke. Hardwood varieties that work particularly well with grilled foods include Alder, Apple, Cherry, Hickory, Mesquite, and Pecan.



## Skewers

Metal skewers should be flat, with long handles. Round skewers allow food to roll when turned, so it may not cook as evenly. Use metal skewers when cooking meat kabobs. Wooden skewers should be soaked in water for an hour before use, and are best used for quick cooking foods such as vegetables and fruits.



## Utensils

Use tongs or a spatula to handle the food instead of a fork, and don't turn the food too often. Piercing the food with a fork will release juices that you want in the meat, and may cause flareups.



# GRILLING GUIDE – Cleaning Your Grill

## Why Clean?

We've all heard the saying 'An ounce of prevention is worth a pound of cure'. This is great advice when it comes to keeping your grill clean.

## Routine Care

Periodic cleaning of this grill is necessary, as grill fires can occur when grease and food debris collect in the bottom of the grill. After each use, remove any remaining food particles from the cooking grate and inside of the grill using a grill brush. Do this after the grill has cooled down. This grill is not designed to be 'burned off' by closing the lid and turning the burners on High for an extended time. The excessive heat generated can cause leftover grease to catch fire, and can cause permanent damage to your grill.

## General Cleaning

Plastic parts: Wash with warm soapy water and wipe dry. Do not use abrasive cleaners, degreasers or a concentrated grill cleaner on plastic parts. Damage to and failure of parts can result.

Porcelain surfaces: Because of glass-like composition, most residue can be wiped away with baking soda/water solution or glass cleaner. Use non-abrasive scouring powder for stubborn stains.

Painted surfaces: Wash with mild detergent or non-abrasive cleaner and warm water. Wipe dry with a soft non-abrasive cloth.

Stainless steel surfaces: Stainless steel can rust under certain conditions. This can be caused by environmental conditions such as chlorine or salt water, or improper cleaning tools such as wire or steel wool. It can also discolor due to heat, chemicals, or grease build-up. To maintain your grill's high quality appearance, wash with mild detergent and warm water, or use a stainless steel grill cleaner. Baked-on grease deposits may require the use of an abrasive plastic cleaning pad. Use only in direction of brushed finish to avoid damage. Do not use abrasive pad on areas with graphics.

Cooking surfaces: Ensure no loose bristles remain on cooking surfaces prior to grilling. It is not recommended to clean cooking surfaces while grill is hot.



## Storing Your Grill

- Clean cooking grates.
- Store grill in dry location.
- When LP cylinder is connected to grill, store outdoors in a well ventilated space and out of reach of children.
- Cover grill if stored outdoors. Choose from a variety of grill covers offered by Char-Broil
- Store grill indoors ONLY if LP cylinder is turned off, disconnected, and removed from grill. Never store LP cylinder indoors.
- When removing grill from storage, follow the 'Cleaning the Burner Assembly' instructions in the Use and Care section of the Product Guide.

## Critters

Spiders like to make their homes in the venturi tubes of grills. These must be inspected and cleaned regularly to ensure there are no blockages. Refer to the Use and Care portion of this Product Guide for complete information.

**EMERGENCIES:** If a gas leak cannot be stopped, or a fire occurs due to gas leakage, call the fire department.

Emergencies	Possible Cause	Prevention/Solution
<b>Gas leaking from cracked/cut/burned hose.</b>	<ul style="list-style-type: none"> <li>• Damaged hose.</li> </ul>	<ul style="list-style-type: none"> <li>• Turn off gas at LP cylinder or at source on natural gas systems. Discontinue use of product and replace valve/hose/regulator. Once valve/hose/regulator replaced conduct complete leak check per manual.</li> </ul>
<b>Gas leaking from LP cylinder.</b>	<ul style="list-style-type: none"> <li>• Mechanical failure due to rusting or mishandling.</li> </ul>	<ul style="list-style-type: none"> <li>• Replace LP cylinder.</li> </ul>
<b>Gas leaking from LP cylinder valve.</b>	<ul style="list-style-type: none"> <li>• Failure of cylinder valve from mishandling or mechanical failure.</li> </ul>	<ul style="list-style-type: none"> <li>• Turn off LP cylinder valve. Return LP cylinder to gas supplier.</li> </ul>
<b>Gas leaking between LP cylinder and regulator connection.</b>	<ul style="list-style-type: none"> <li>• Improper installation, connection not tight, and/or failure of rubber seal in cylinder valve.</li> </ul>	<ul style="list-style-type: none"> <li>• Turn off LP cylinder valve. Remove regulator from cylinder and visually inspect rubber seal in cylinder valve for damage. If damage or cannot correct leak replace cylinder. See LP Cylinder Leak Test and Connecting Regulator to the LP Cylinder.</li> </ul>
<b>Fire coming through control panel.</b>	<ul style="list-style-type: none"> <li>• Fire in burner tube section of burner due to blockage.</li> </ul>	<ul style="list-style-type: none"> <li>• Turn off control knobs and LP cylinder valve. Leave lid open to allow flames to die down. After fire is out and grill is cold, remove burner and inspect for spider nests or rust. See Natural Hazard and Cleaning the Burner Assembly pages.</li> </ul>
<b>Grease fire or continuous excessive flames above cooking surface.</b>	<ul style="list-style-type: none"> <li>• Too much grease buildup in burner area.</li> </ul>	<ul style="list-style-type: none"> <li>• Turn off control knobs and LP cylinder valve. Leave lid open to allow flames to die down. After cooling, clean food particles and excess grease from inside firebox area, grease tray, and other surfaces.</li> </ul>



# Troubleshooting



Problem	Possible Cause	Prevention/Solution
<p><b>Burner(s) will not light using ignitor.</b></p> <p><b>(See Electronic Ignition Troubleshooting also)</b></p> <p><b>Continued on next page.</b></p>	<p><b>GAS ISSUES:</b></p> <ul style="list-style-type: none"> <li>• Trying to light wrong burner.</li> <li>• Burner not engaged with control valve.</li> <li>• Obstruction in burner.</li> <li>• No gas flow.</li> <li>• Coupling nut and LP cylinder valve not fully connected.</li> </ul> <p><b>ELECTRICAL ISSUES:</b></p> <ul style="list-style-type: none"> <li>• Electrode cracked or broken; “sparks at crack.”</li> <li>• Electrode tip not in proper position. (Does not apply to SUREFIRE.)</li> <li>• Wire and/or electrode covered with cooking residue.</li> <li>• Wires are loose or disconnected.</li> <li>• Wires are shorting (sparking) between ignitor and electrode.</li> <li>• Dead battery.</li> </ul> <p><b>ELECTRONIC IGNITION:</b></p> <ul style="list-style-type: none"> <li>• No spark, no ignition noise.</li> <li>• No spark, some ignition noise.</li> <li>• Sparks, but not at electrode or at full strength.</li> </ul>	<ul style="list-style-type: none"> <li>• See instructions on control panel and in Use and Care section.</li> <li>• Make sure valves are positioned inside of burner tubes.</li> <li>• Ensure burner tubes are not obstructed with spider webs or other matter. See cleaning section of Use and Care.</li> <li>• Make sure LP cylinder is not empty. If LP cylinder is not empty, refer to “Sudden drop in gas flow.”</li> <li>• Turn the coupling nut approximately one-half to three-quarters additional turn until solid stop. Tighten by hand only - do not use tools.</li> <li>• Replace electrode(s).</li> </ul> <p>Main Burners:</p> <ul style="list-style-type: none"> <li>• Tip of electrode should be pointing toward gas port opening on burner. The distance should be 1/8” to 1/4”. Adjust if necessary.</li> </ul> <p>Sideburner:</p> <ul style="list-style-type: none"> <li>• Tip of electrode should be pointing toward gas port opening on burner. the distance should be 1/8” to 3/16”. Adjust if necessary.</li> <li>• Clean wire and/or electrode with rubbing alcohol and clean swab.</li> <li>• Reconnect wires or replace electrode/wire assembly.</li> <li>• Replace ignitor wire/electrode assembly.</li> <li>• Replace with a new alkaline battery.</li> <li>• See Section I of Electronic Ignition System.</li> </ul>



		<ul style="list-style-type: none"> <li>• See Section II of Electronic Ignition System.</li> <li>• See Section III of Electronic Ignition System.</li> </ul>
<p><b>Burner(s) will not match light.</b></p>	<ul style="list-style-type: none"> <li>• See “GAS ISSUES:” .</li> <li>• Match will not reach.</li> <li>• Improper method of match-lighting.</li> </ul>	<ul style="list-style-type: none"> <li>• Use long-stem match (fireplace match).</li> <li>• See “Match-Lighting” section of Use and Care.</li> </ul>



Problem	Possible Cause	Prevention/Solution
<b>Sudden drop in gas flow or low flame.</b>	<ul style="list-style-type: none"> <li>• Out of gas.</li> <li>• Excess flow valve tripped.</li> <li>• Vapor lock at coupling nut/LP cylinder connection.</li> </ul>	<ul style="list-style-type: none"> <li>• Check for gas in LP cylinder.</li> <li>• Turn off knobs, wait 30 seconds and light grill. If flames are still low, turn off knobs and LP cylinder valve. Disconnect regulator. Reconnect regulator and leak-test. Turn on LP cylinder valve, wait 30 seconds and then light grill.</li> <li>• Turn off knobs and LP cylinder valve. Disconnect coupling nut from cylinder. Reconnect and retry.</li> </ul>
<b>Flames blow out.</b>	<ul style="list-style-type: none"> <li>• High or gusting winds.</li> <li>• Low on LP gas.</li> <li>• Excess flow valve tripped.</li> </ul>	<ul style="list-style-type: none"> <li>• Turn front of grill to face wind or increase flame height by turning gas valve to a higher position.</li> <li>• Refill LP cylinder.</li> <li>• Refer to “Sudden drop in gas flow” above.</li> </ul>
<b>Flare-up.</b>	<ul style="list-style-type: none"> <li>• Grease buildup.</li> <li>• Excessive fat in meat.</li> <li>• Excessive cooking temperature.</li> </ul>	<ul style="list-style-type: none"> <li>• Clean burners and inside of grill/firebox.</li> <li>• Trim fat from meat before grilling.</li> <li>• Adjust (lower) temperature accordingly.</li> </ul>
<b>Persistent grease fire.</b>	<ul style="list-style-type: none"> <li>• Grease trapped by food buildup around burner system.</li> </ul>	<ul style="list-style-type: none"> <li>• Turn knobs to OFF. Turn gas off at LP cylinder. Leave lid in position and let fire burn out. After grill cools, remove and clean all parts.</li> </ul>
<b>Flashback (fire in burner tube(s)).</b>	<ul style="list-style-type: none"> <li>• Burner and/or burner tubes are blocked.</li> </ul>	<ul style="list-style-type: none"> <li>• Turn knobs to OFF. Clean burner and/or burner tubes. See burner cleaning section of Use and Care.</li> </ul>
<b>One burner does not light from other burner(s).</b>	<ul style="list-style-type: none"> <li>• Grease buildup or food particles in end(s) of carryover tube(s).</li> </ul>	<ul style="list-style-type: none"> <li>• Clean carry-over tube(s) with wire brush.</li> </ul>



## Troubleshooting - Electronic Ignition



Problem (Ignition)	Possible Cause	Check Procedure	Prevention/Solution
<p><b>SECTION I</b></p> <p><b>No sparks appear at any electrodes when Electronic Ignition Button is pressed; no noise can be heard from spark module.</b></p>	<ul style="list-style-type: none"> <li>• Battery not installed properly.</li> <li>• Dead battery.</li> <li>• Button assembly not installed properly.</li> <li>• Faulty spark module.</li> </ul>	<ul style="list-style-type: none"> <li>• Check battery orientation.</li> <li>• Has battery been used previously?</li> <li>• Check to insure threads are properly engaged. Button should travel up and down without binding.</li> <li>• If no sparks are generated with new battery and good wire connections, module is faulty.</li> </ul>	<ul style="list-style-type: none"> <li>• Install battery (make sure that “+” and “-” connectors are oriented correctly, with “+” on cap end.)</li> <li>• Replace battery with new alkaline battery.</li> <li>• Unscrew button cap assembly and reinstall, making sure threads are aligned and engaged fully.</li> <li>• Replace spark module assembly.</li> </ul>
<p><b>SECTION II</b></p> <p><b>No sparks appear at any electrodes when Electronic Ignition Button is pressed; noise can be heard from spark module.</b></p>	<ul style="list-style-type: none"> <li>• Output lead connections not connected.</li> </ul>	<ul style="list-style-type: none"> <li>• Are output connections on and tight?</li> </ul>	<ul style="list-style-type: none"> <li>• Remove and reconnect all output connections at module and electrodes.</li> </ul>
<p><b>SECTION III</b></p> <p><b>Sparks are present but not at all electrodes and/or not at full strength</b></p>	<ul style="list-style-type: none"> <li>• Output lead connections not connected.</li> <li>• Arcing to grill away from burner(s).</li> <li>• Weak battery.</li> <li>• Electrodes are wet.</li> <li>• Electrodes cracked or</li> </ul>	<ul style="list-style-type: none"> <li>• Are output connections on and tight?</li> <li>• If possible, observe grill in dark location. Operate ignition system and look for arcing between output wires and grill frame.</li> <li>• All sparks present but weak or at slow rate.</li> <li>• Has moisture accumulated on</li> </ul>	<ul style="list-style-type: none"> <li>• Remove and reconnect all output connections at module and electrodes.</li> <li>• If sparks are observed other than from burner(s), wire insulation may be damaged. Replace wires.</li> </ul>



	<p>broken “sparks at crack”.</p>	<p>electrode and/or in burner ports?</p> <ul style="list-style-type: none"> <li>• Inspect electrodes for cracks.</li> </ul>	<ul style="list-style-type: none"> <li>• Replace battery with a new alkaline battery.</li> <li>• Use paper towel to remove moisture.</li> <li>• Replace cracked or broken electrodes.</li> </ul>
--	----------------------------------	---	--

## ASSEMBLY

**NOTE:** DO NOT over tighten screws and washers that come into contact with porcelain coated surfaces. Over tightening may cause the porcelain coating to crack and break, resulting in exposed metal that will be prone to rust.

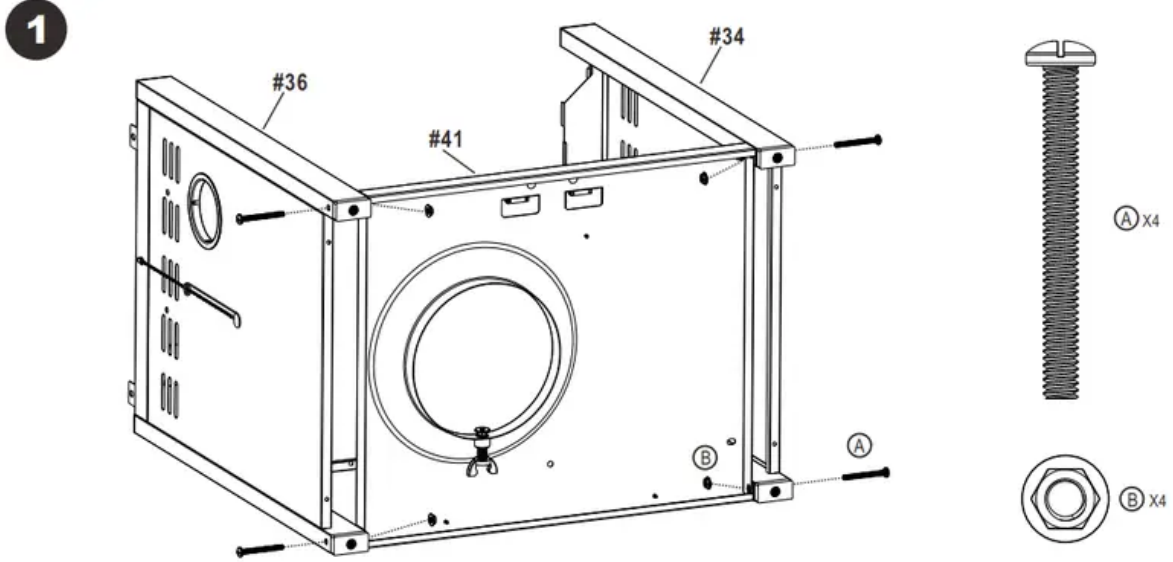

**2**

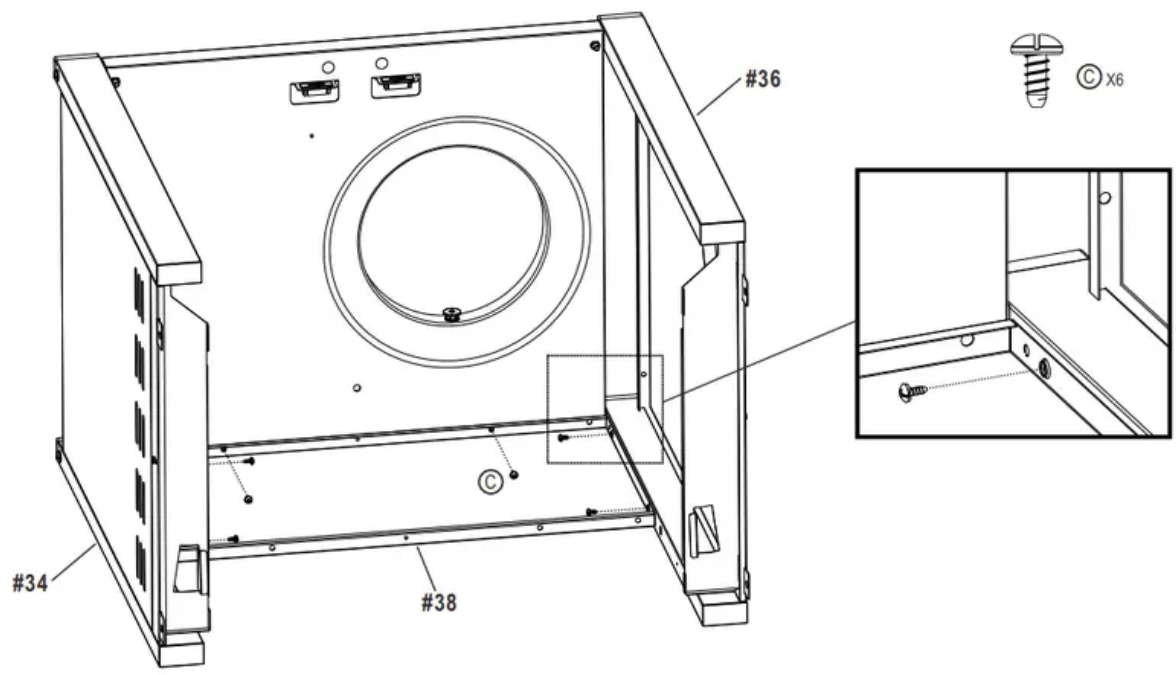

**3**

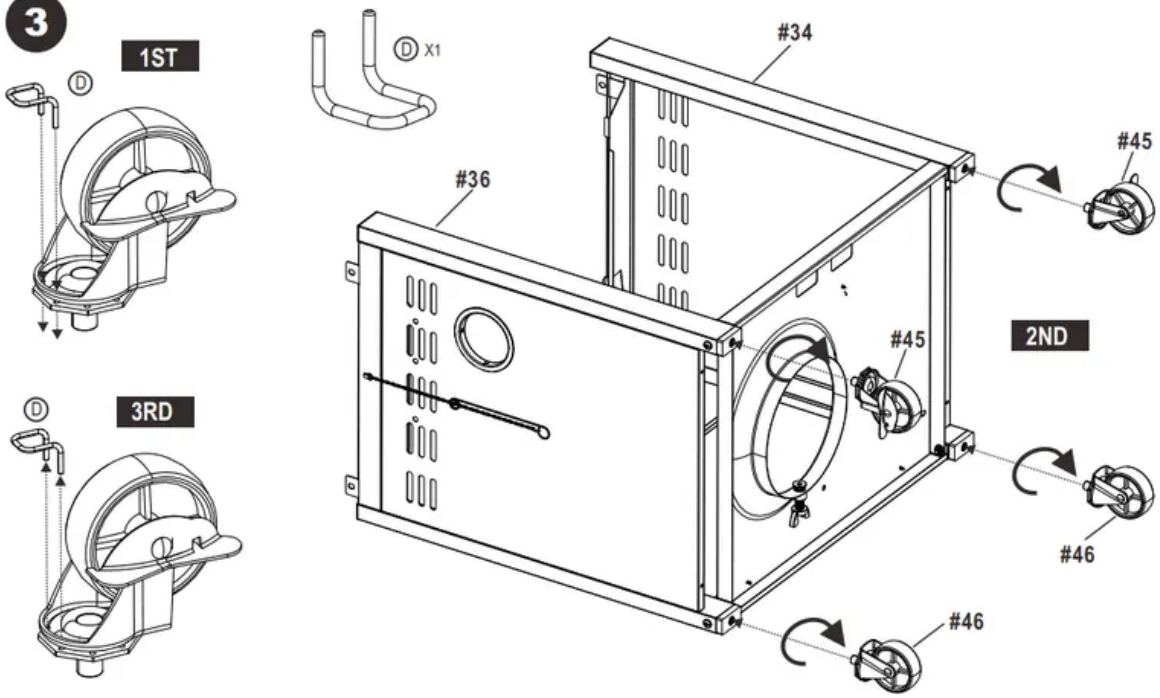

After all 4 casters are secure remove the Caster Pin (D) and save for future maintenance



4

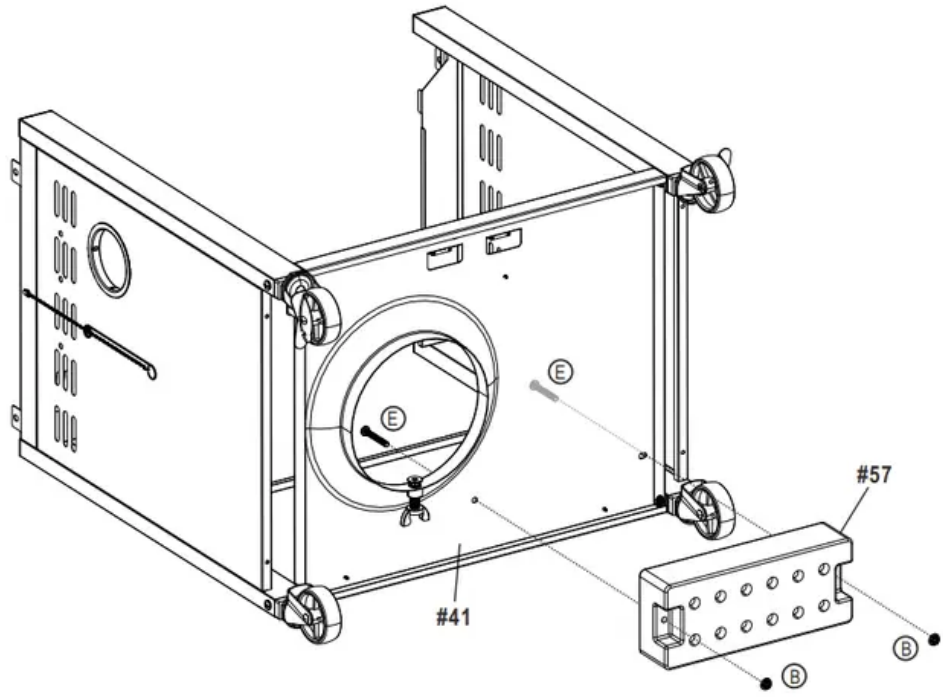
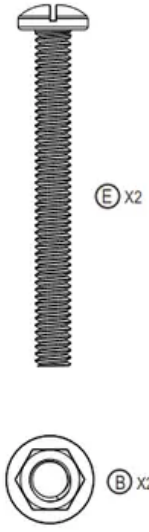

5

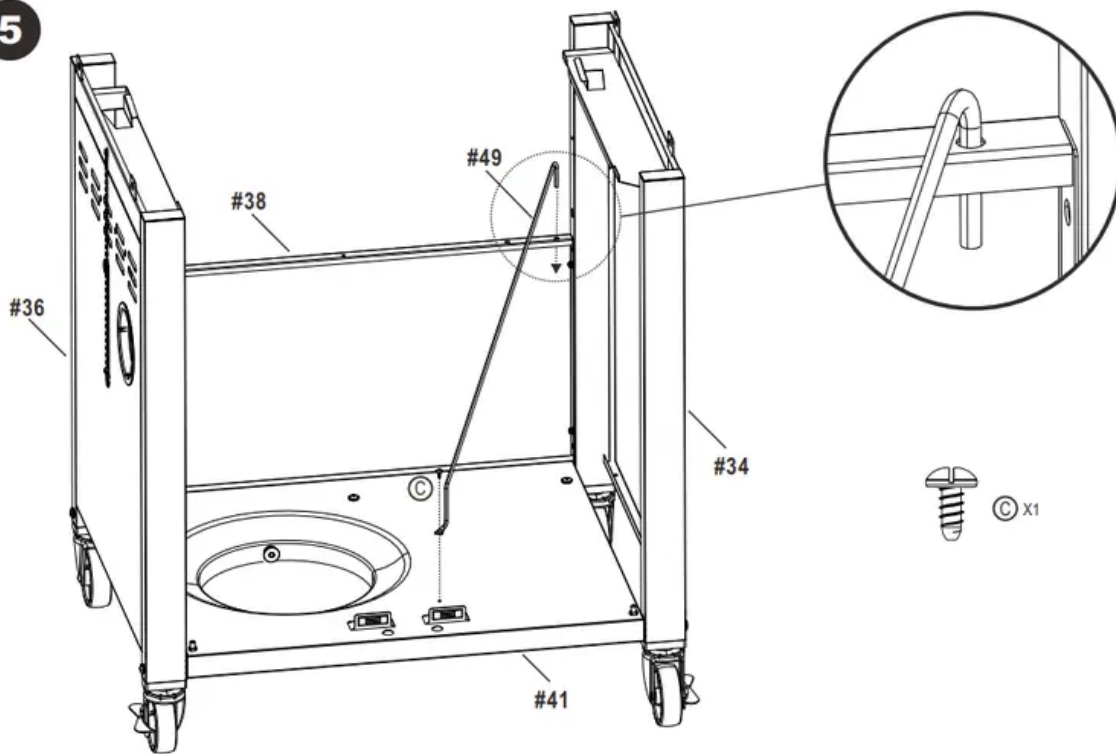

6

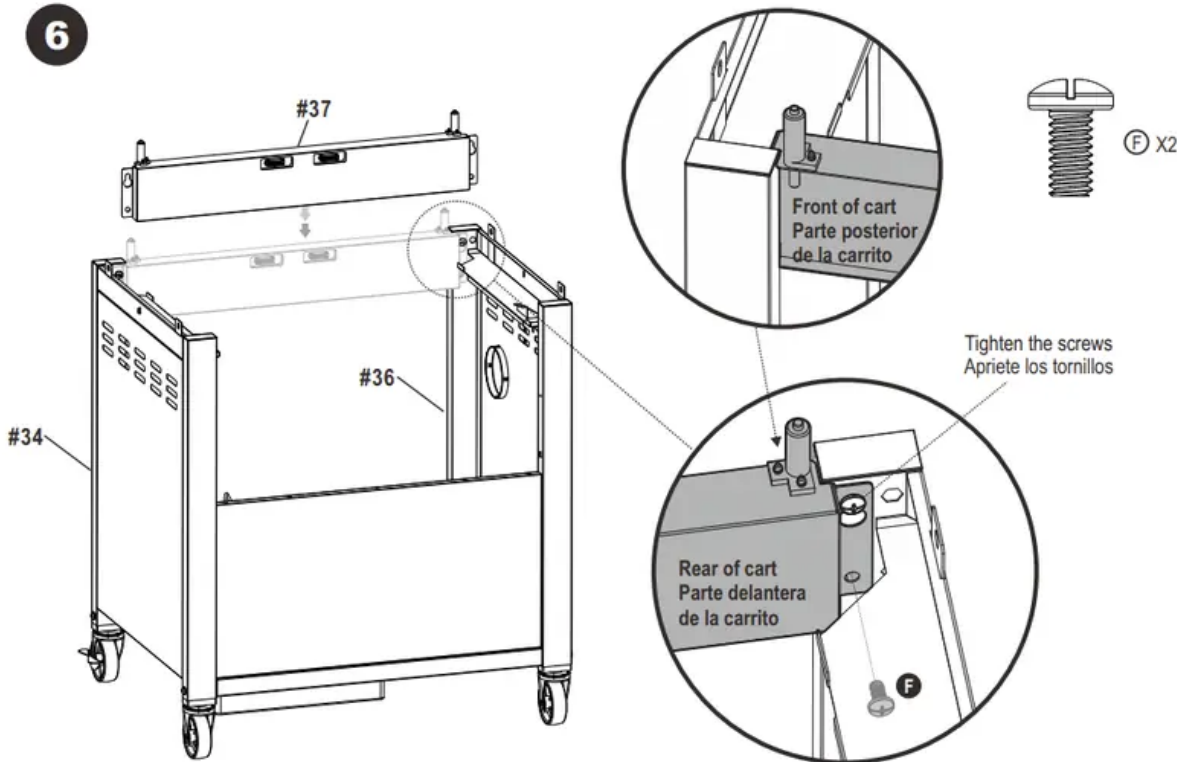

7

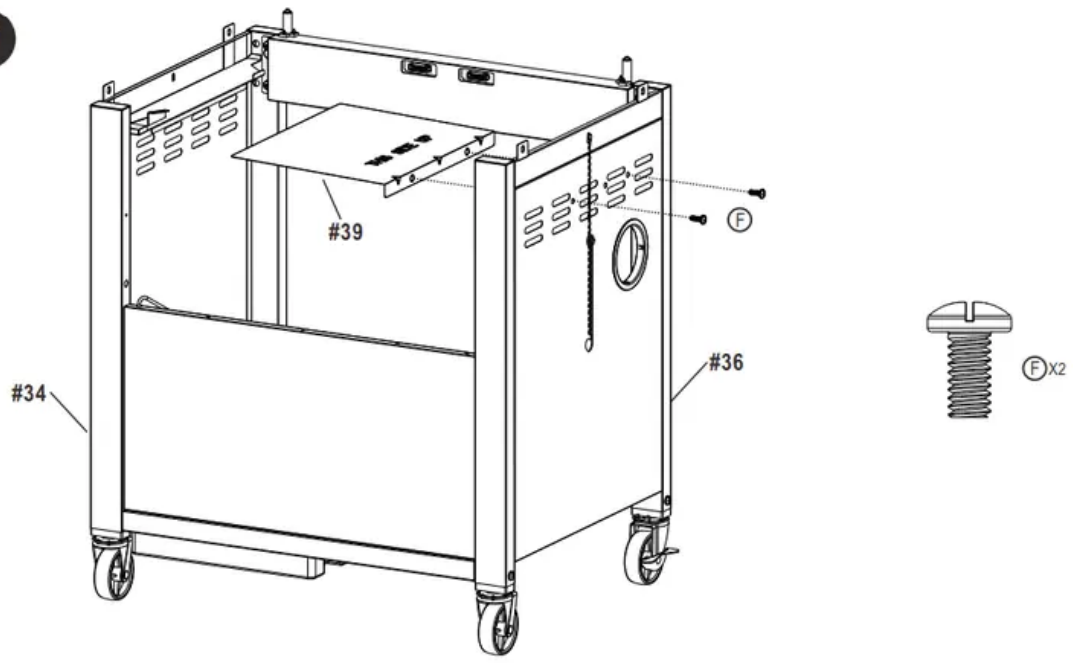

8

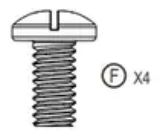

2ND

1ST

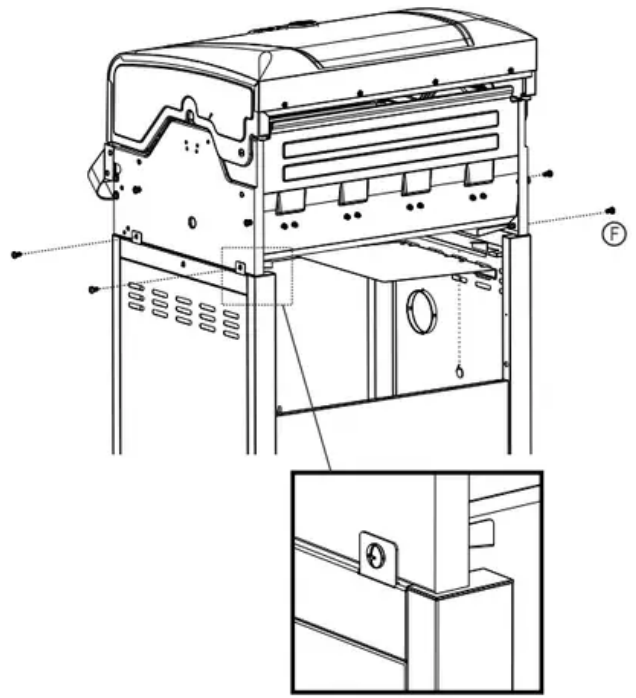
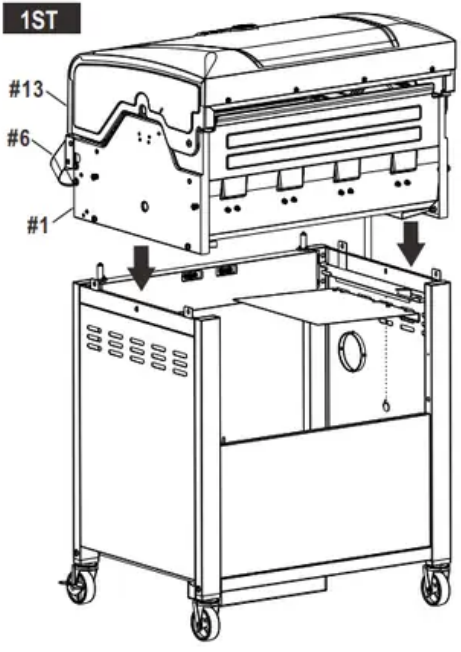

9

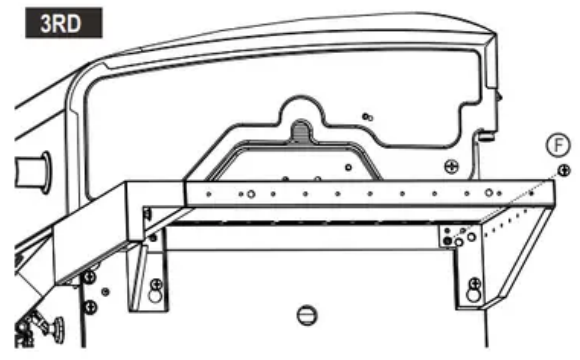
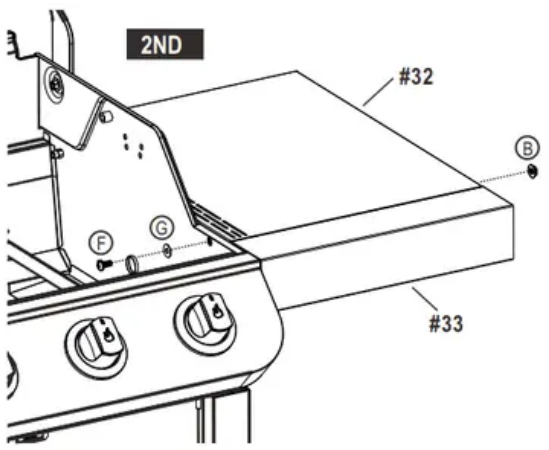
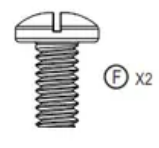
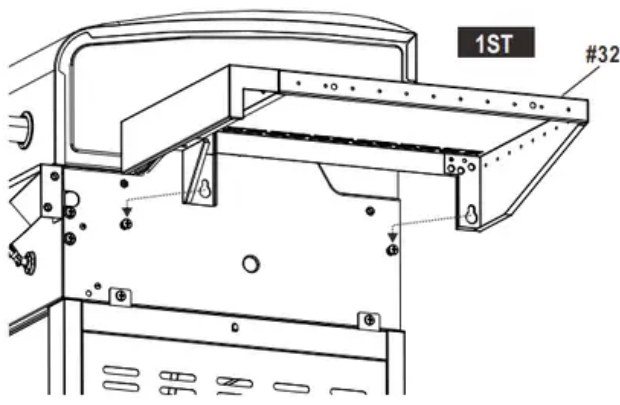

10

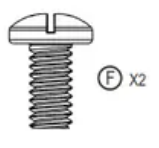
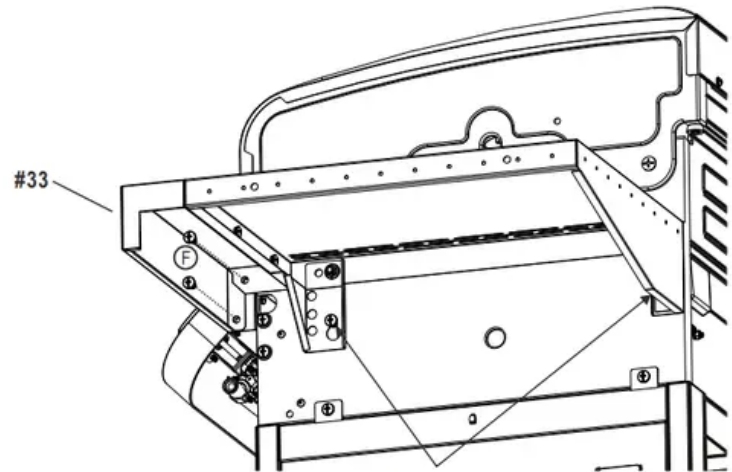

Tighten the screws  
Apriete los tornillos



11

1ST

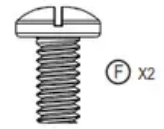
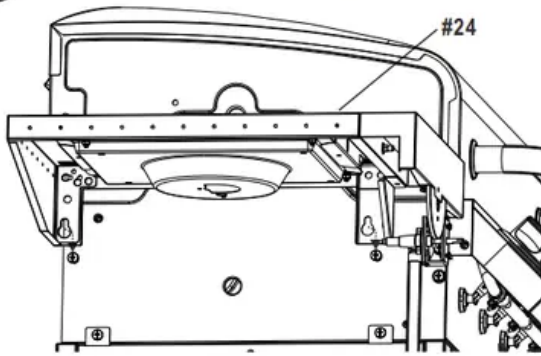

2ND

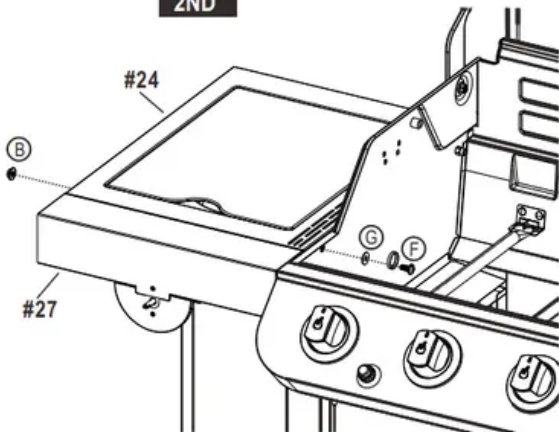

3RD

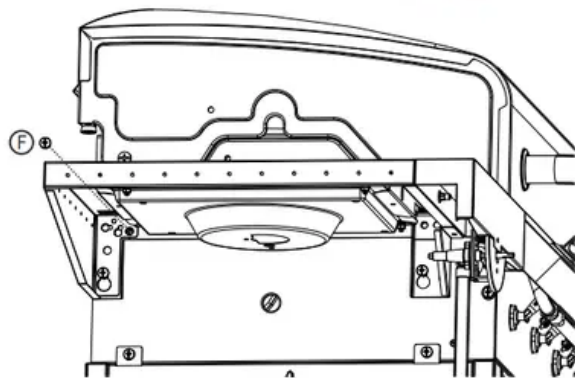

12

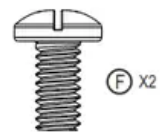
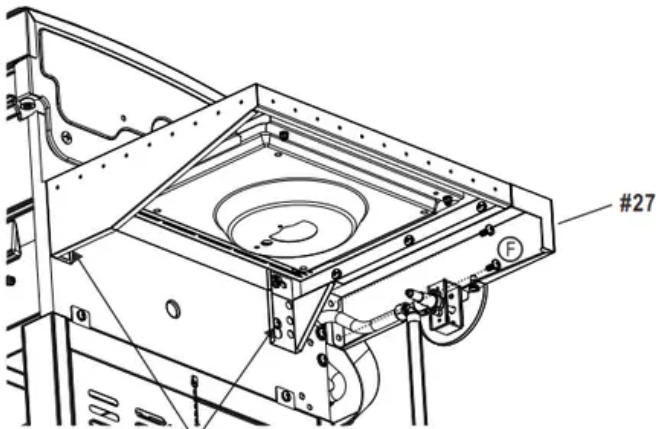

Tighten the screws  
Apriete los tornillos





15

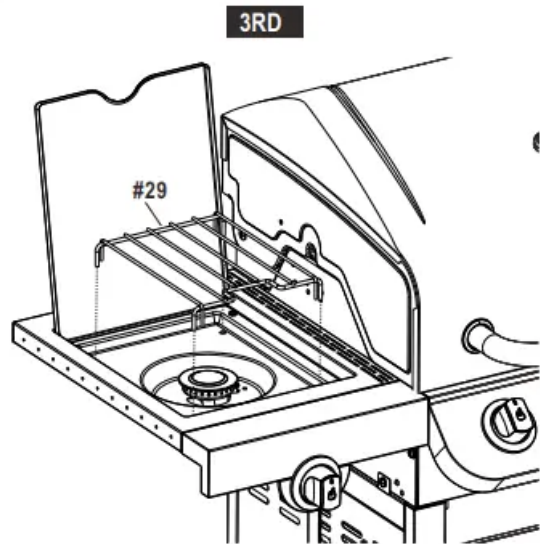
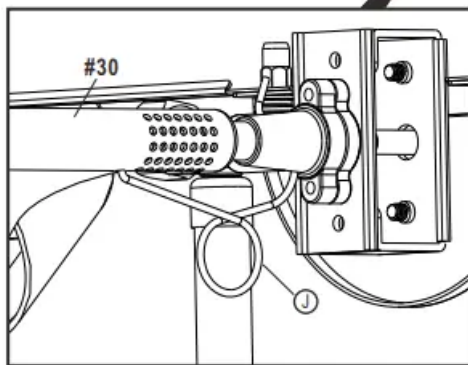
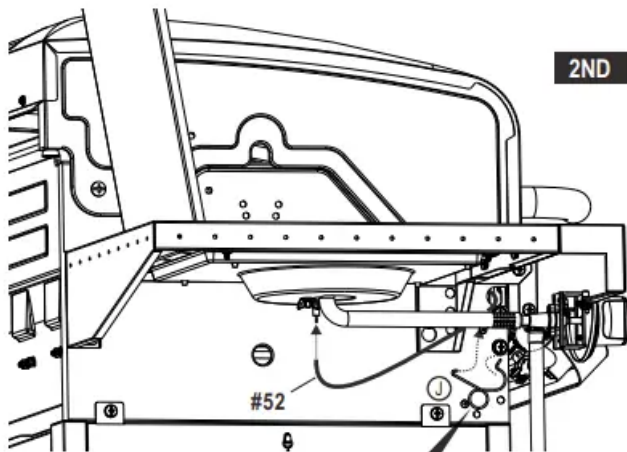
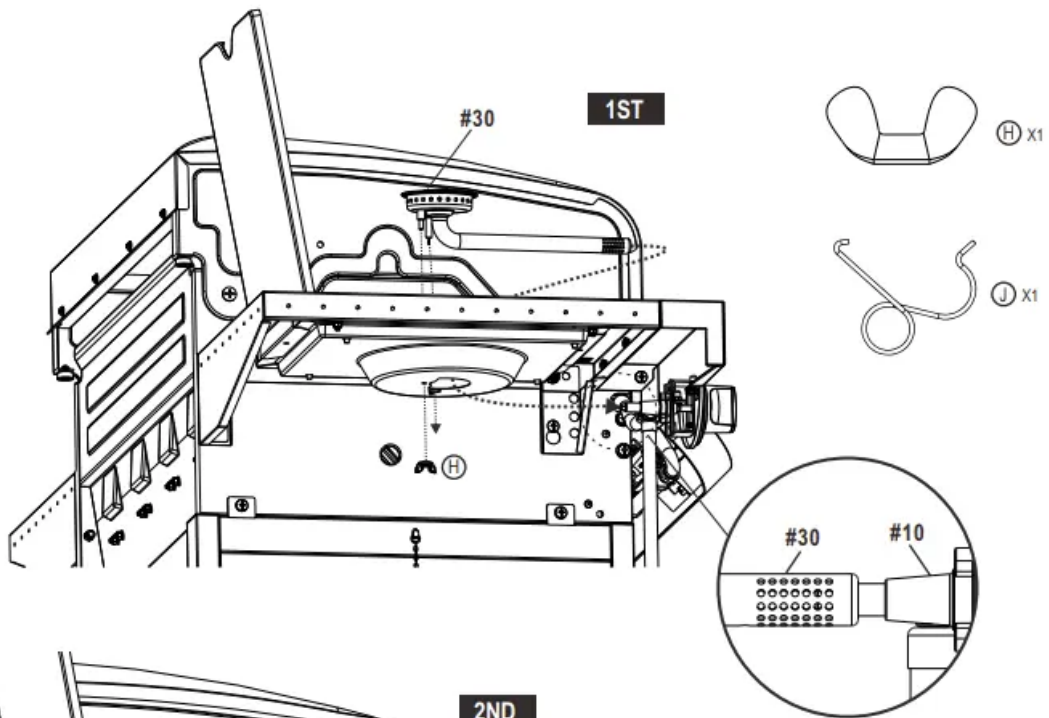

16

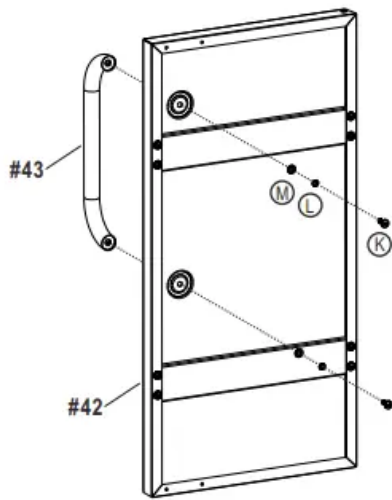

1ST

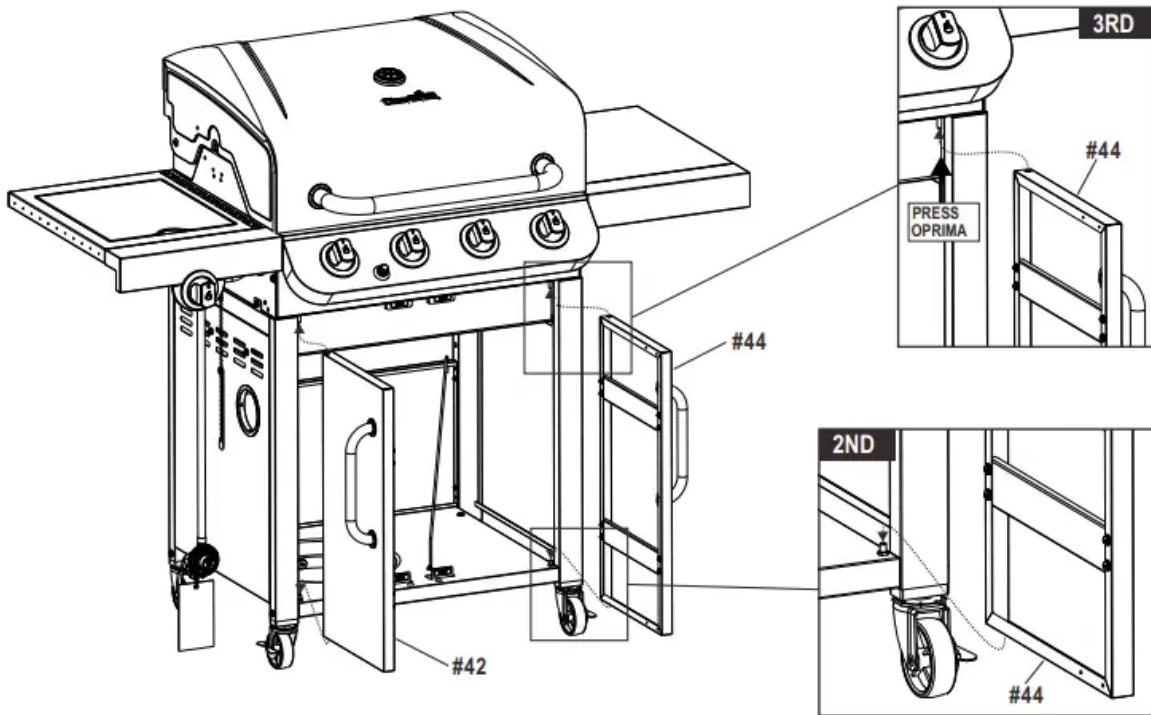
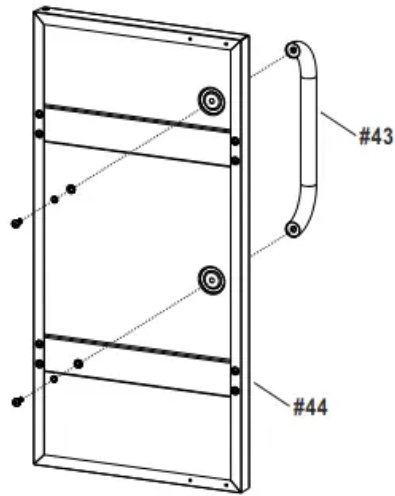

17

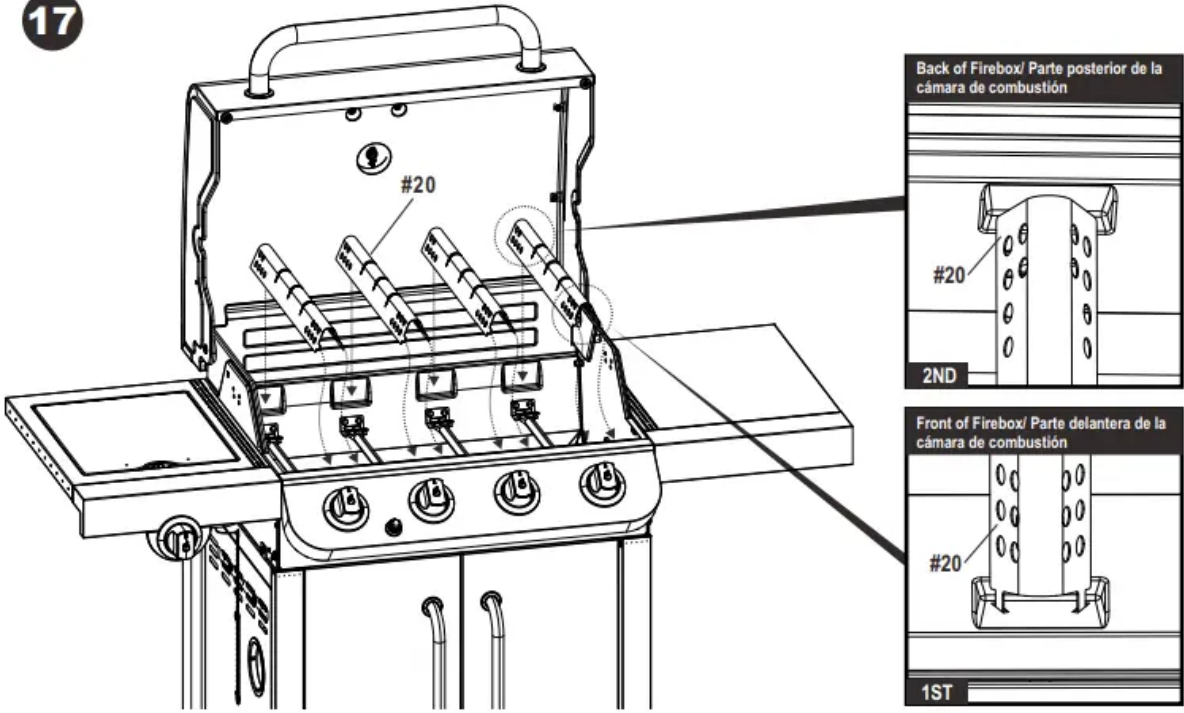

18

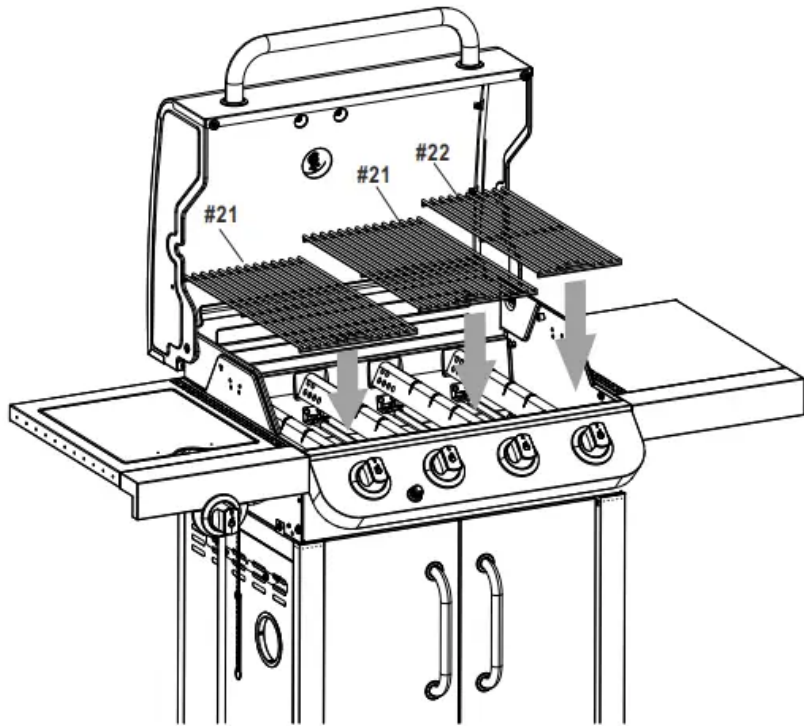

19

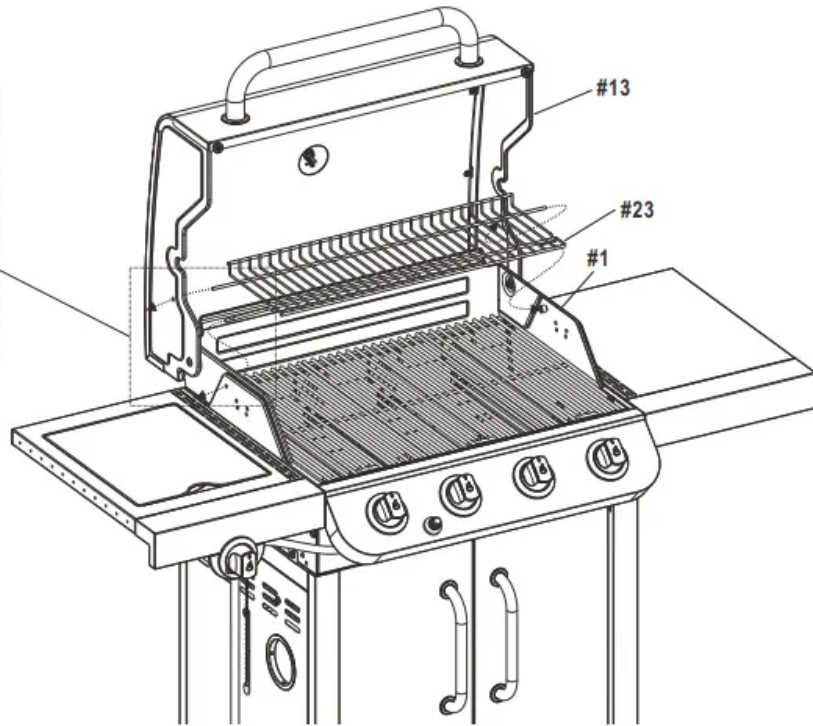
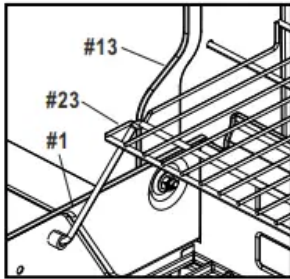

20

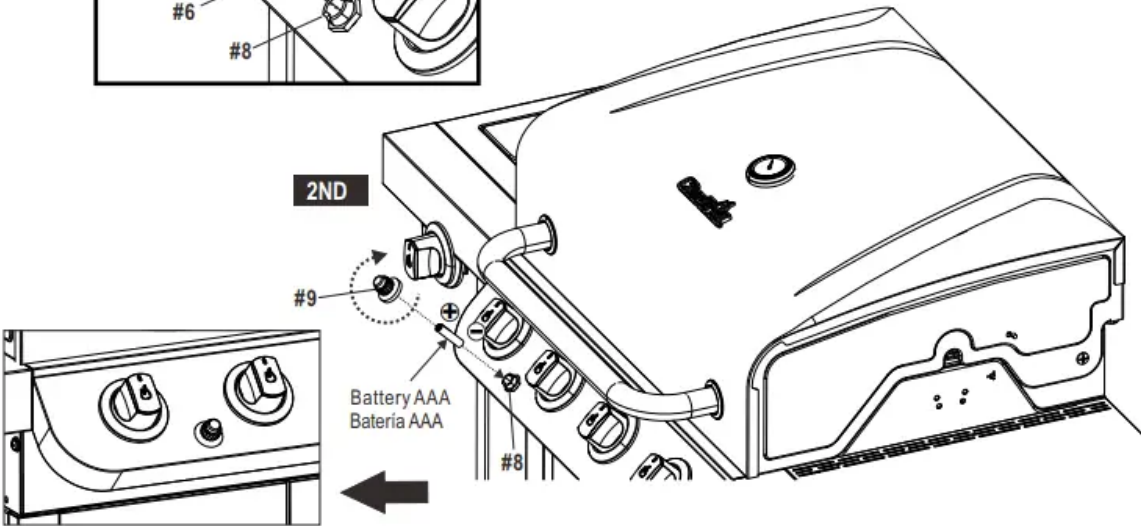
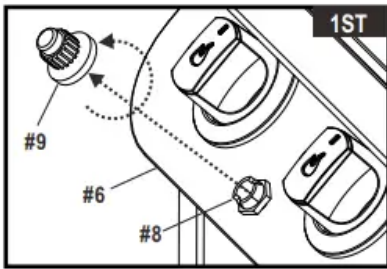

21

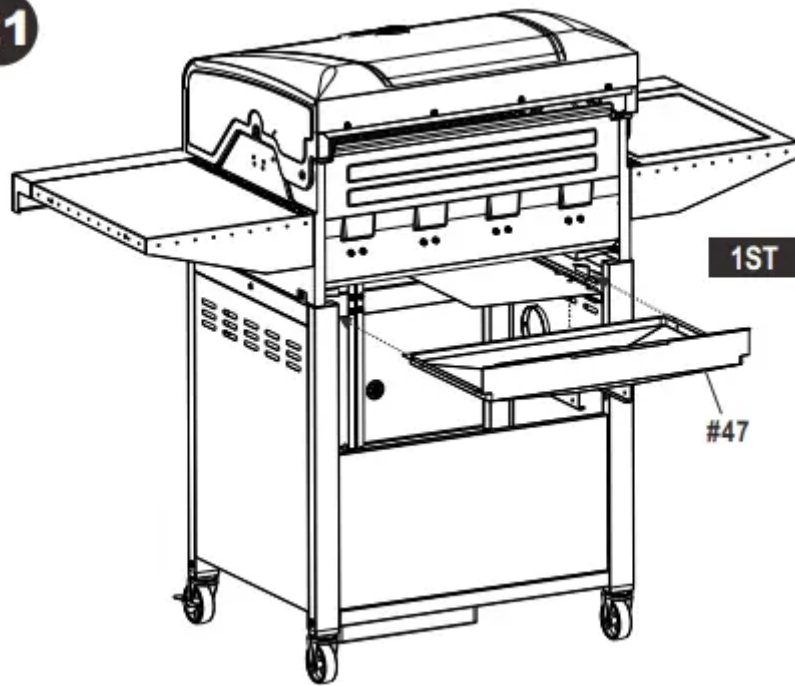

**CAUTION** Failure to install grease tray and grease pan will cause hot grease to drip from bottom of grill with risk of fire or property damage.

2ND

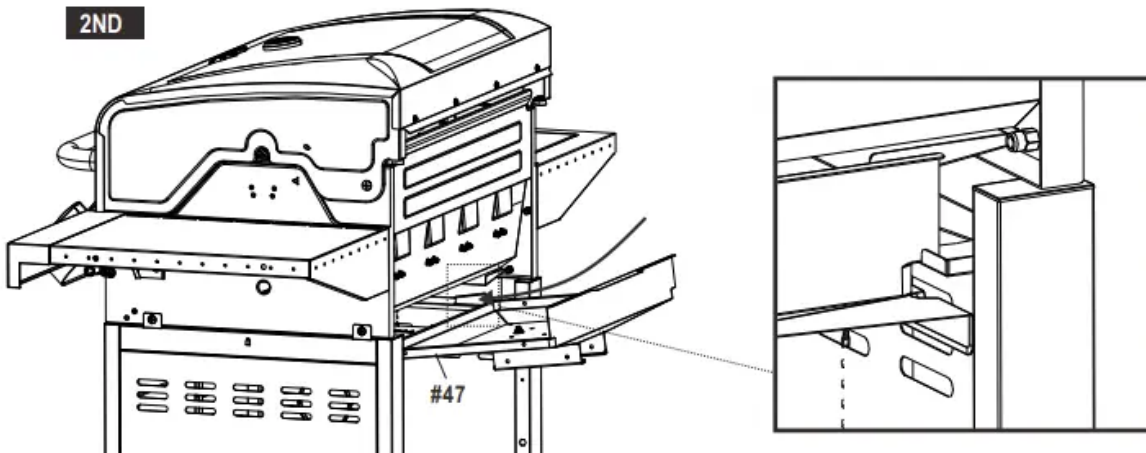

3RD

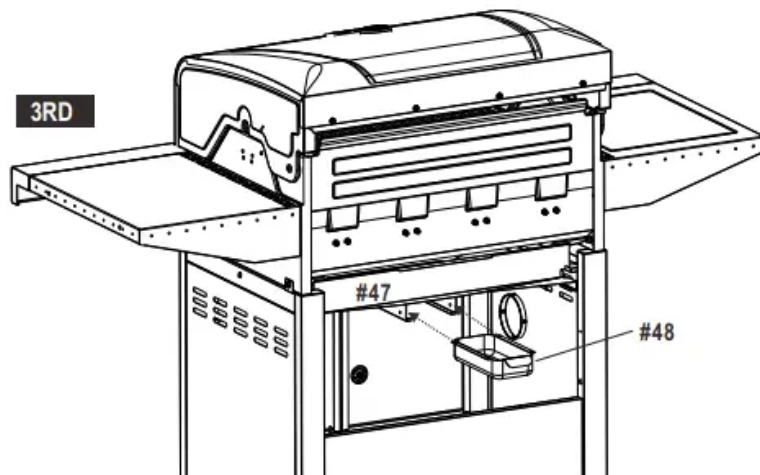

22

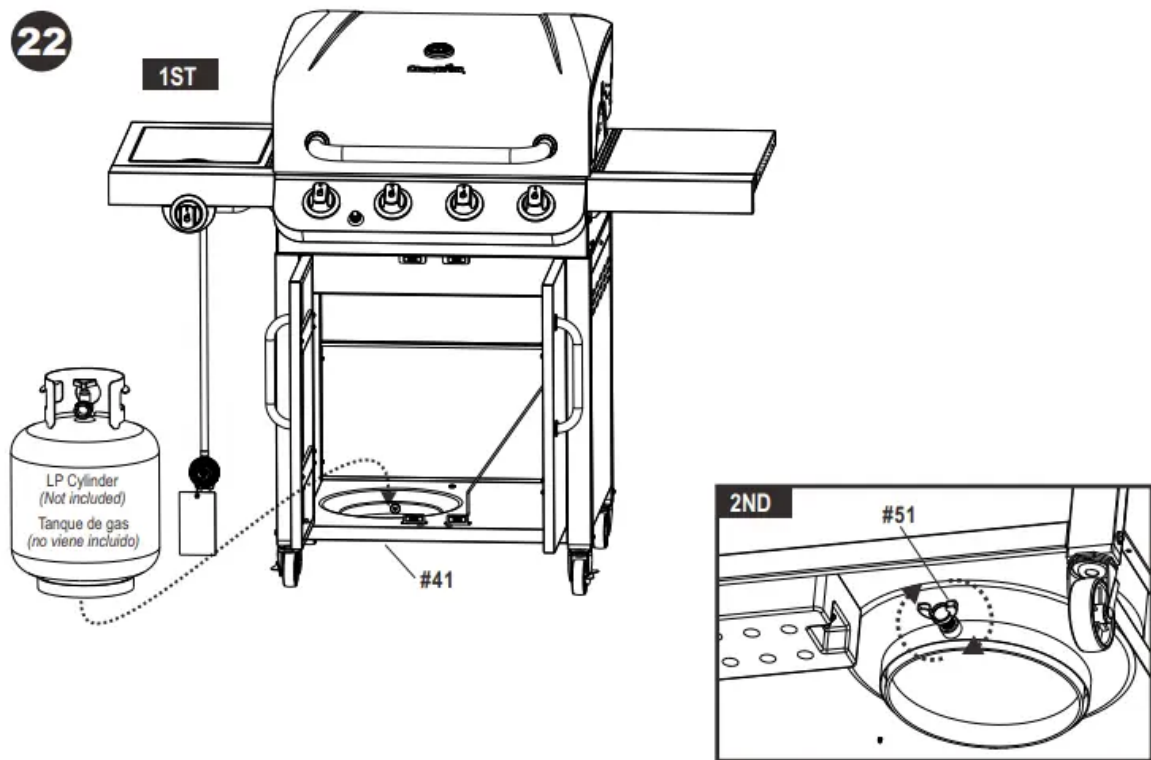

**CAUTION** Cylinder valve must face to front of cart once tank is attached. Failure to install cylinder correctly may allow gas hose to be damaged in operation, resulting in the risk of fire.

3RD

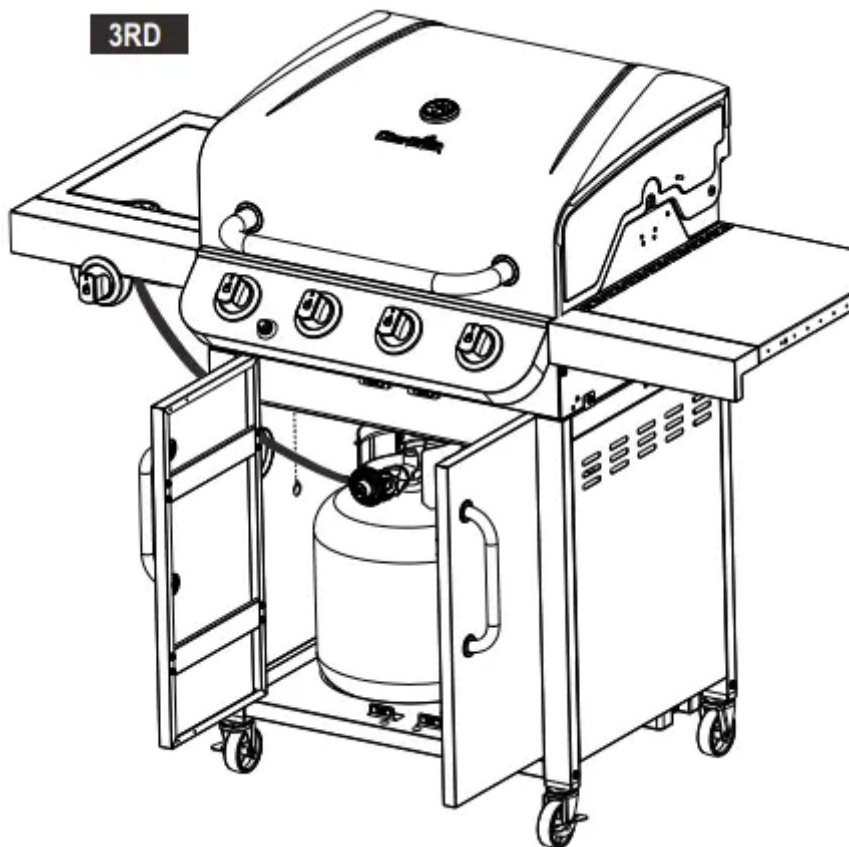

**Warning**

This content is compiled from multiple sources and is provided for reference purposes only. It may not be complete or fully applicable to all situations. If you are unable to resolve your issue, please contact the product manufacturer or an authorized service provider for official support.

---

Document generated by [ManualsFile](#)