

Getting to Know Your Hoover® SmartWash™



1. Triggerless Handle Design
2. Clean Water Tank
3. Filter
4. Dirty Water/Recovery Tank
5. Hose Connection
6. Removable Recovery Nozzle
7. Automatic Wash/ Dry LED Display
8. Removable FlexDuo™ PowerBrushes
9. Solution Tank
10. Carry Handle
11. Cord Wrap
12. Handle release Pedal
13. On/Off Pedal

Tools & Accessories:



2-in-1 Antimicrobial Tool*:

Antimicrobial tool that helps prevent bacteria growth and odors allows you to choose between two inserts.

- A. The rubber nub insert is for unpleasant stain removal and hygienic clean ups
- B. The bristle insert is for tough scrubbing power

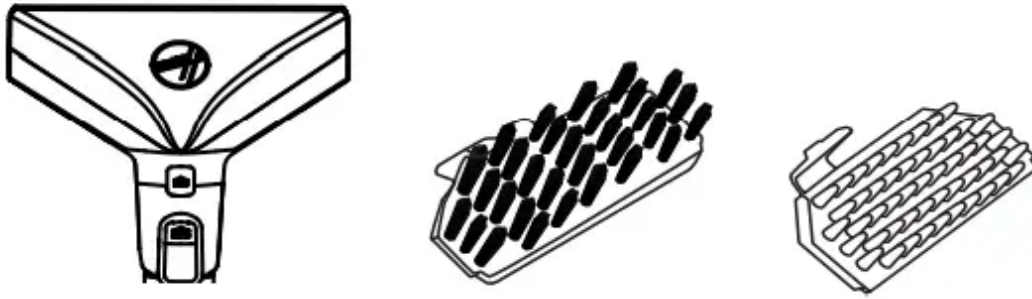

Before You Begin Cleaning

Vacuum carpet and upholstery thoroughly with a Hoover vacuum before use.

Don't use the carpet cleaner as a traditional vacuum cleaner.

Use your Hoover carpet cleaner only if upholstery fabric is marked with a "W" (for "wet" clean) or "S/W" (for "solvent/dry" or "wet" clean). Don't clean fabric marked "S" ("solvent/dry" clean only).

Test for colorfastness in a small, hidden area. Gently rub surface with a dampened white cloth. Wait ten minutes and check for color removal or bleed with a white paper towel.

Move furniture out of area to be cleaned. Place aluminum foil or wax paper under legs of furniture too heavy to move to prevent wood finishes from staining carpet. Pin up furniture skirts and draperies.

Pretreat spots and heavy traffic areas with a Hoover® Cleaning Solution*. See the "Cleaning Solutions" section.

*Available at additional cost if not included with your model.

Pretreating:

For best results, pretreat stains with a Hoover spot treatment (see Hoover Cleaning Solution Guide, pg. 18) to help loosen and remove even the most stubborn stains.

NOTE: To prevent staining, use plastic or aluminum foil to protect wood or metal surfaces from possible water spray.

NOTE: To avoid damage to wood floors underneath area rugs or carpet, place waterproof material (ex: plastic) underneath them before cleaning

CAUTION Do not clean over floor electrical outlets. Water will drip from the brushes and underside of the product after use and may puddle. To avoid damage to wood and laminate flooring and to avoid potential slip hazard, after use (a) do not leave the product on wood and laminate surfaces and move to a hard surface and (b) place unit on an absorbent material (such as a towel) to soak up drips.

IMPORTANT For full suction, it is important that the Dirty Water Tank is properly secured before cleaning.

Continue using dry strokes until little water is visible passing through the nozzle. For best results, Hoover recommends rinsing carpet with water only. This removes residual carpet cleaning solution. Remove Solution Tank and repeat. For heavily soiled areas, repeat. Avoid saturating carpet.

NOTE: Empty Dirty Water Tank when the motor sound becomes higher pitched and there is a loss in suction (see "Automatic shut-off"). You will also see the float rise and shut off suction at the same time.

Getting Started With Your SmartWash™ Carpet Cleaner

Assembly

1 Insert the handle into the base until you hear a "click".

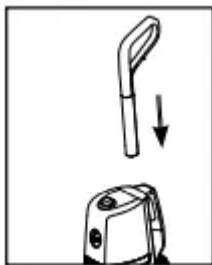

2 Wrap the power cord around the cord hooks for convenient storage.

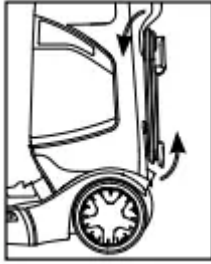

Fill the Clean Water Tank

1 Lift up to remove the Clean Water Tank.

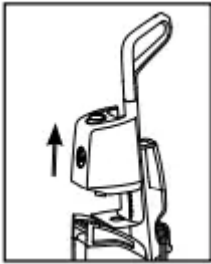

2 Remove the cap and add warm water to the top of tank. Replace cap.



3 Align Clean Water Tank with the body of the unit and press FIRMLY into place.

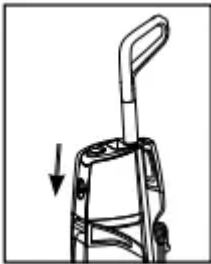

Fill the Solution Tank

1 Remove the Solution Tank from the back of the unit.

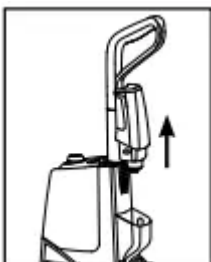

2 Remove the cap and fill with Hoover® Cleaning Solution to the top of the tank. Replace cap.

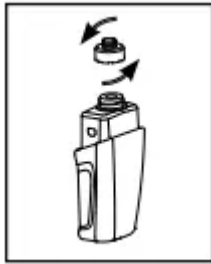

3 Place the Solution Tank back into the unit and press FIRMLY into place.

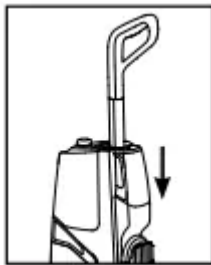

Using Your SmartWash™ Carpet Cleaner

1 Unwrap the power cord and plug unit in an electrical outlet.

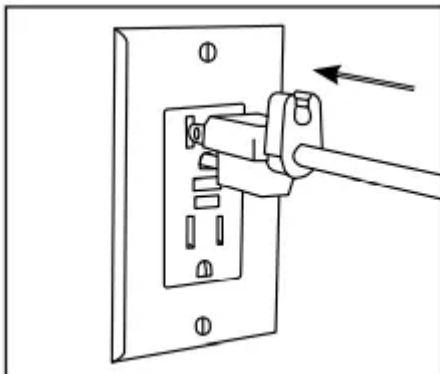

2 Step on the Handle Release Pedal to recline the unit for cleaning position.

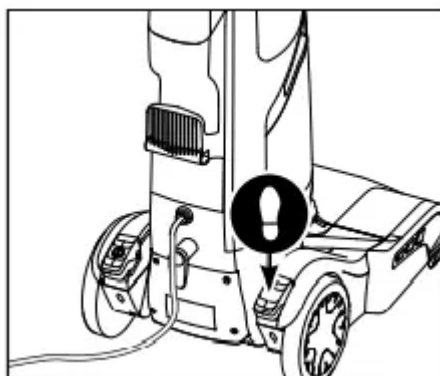

3 Step on the Power Pedal to turn ON

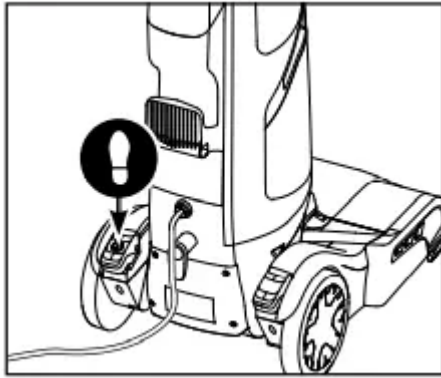

4 Slowly move forward. The unit will automatically dispense the optimal amount of water and cleaning solution.



5 Slowly pull backward. The unit will automatically dry your carpets by extracting the water



6 When your cleaning is complete and you want to reduce the dry time, press the Dry Only button. The Dry Only mode will extract remaining water from your carpet. Continue in this mode until little water is visibly passing through the nozzle.

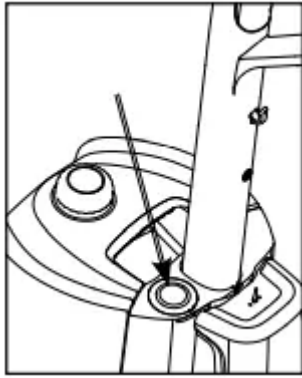

7 For best results, Hoover recommends rinsing the carpet with clean water only. This will remove residual carpet cleaning solution from your carpets. To Rinse with clean water only, remove the Solution Tank and then repeat steps 4 through 6.

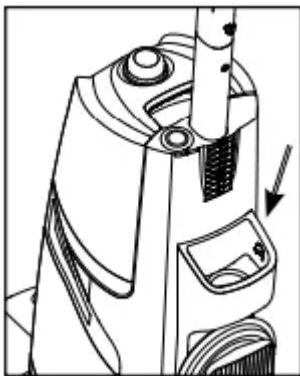

Maintenance

How to Empty

1 Turn the cleaner off and unplug from electrical outlet

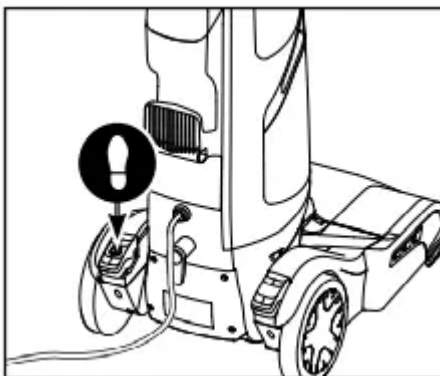

2 Grab the Dirty Water Tank handle and pull up to release. Remove Tank from carpet cleaner base at an angle

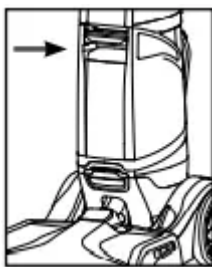

3 Place on a flat surface and unlatch Dirty Water Tank lid to remove top of tank.

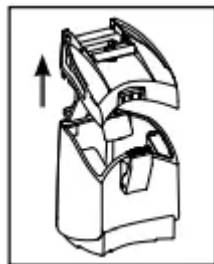

4 Empty tank, rinse, wipe filter clean and allow to air dry.

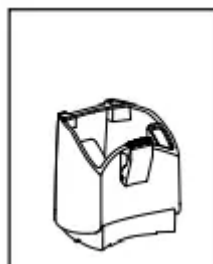

Dirty Water Tank: Your carpet cleaner is equipped with a shut off float within your dirty water tank. When the dirty water tank becomes full, the float will rise, shutting off the air flow through the nozzle. Once the float is activated, empty the dirty water tank.

How to Remove and Clean Nozzle

1 To prevent possible leaking, remove and empty Clean Water Tank, Dirty Water Tank and Solution Tank.



2 With handle in upright position, lift up on the Nozzle release then pull Nozzle forward to remove from carpet cleaner. BE CAREFUL not to instantly pull nozzle straight up

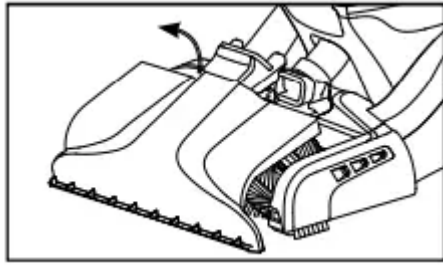

3 Rinse debris from Nozzle.

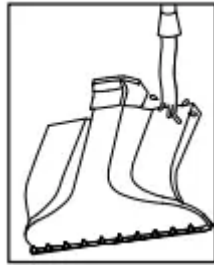

4 Position Nozzle onto foot, making sure to align the tabs at the top of the Nozzle with the notches inside the foot.

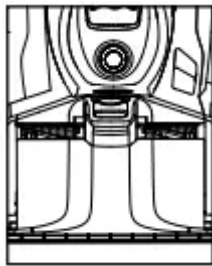

5 Slide Nozzle forward to snap into position

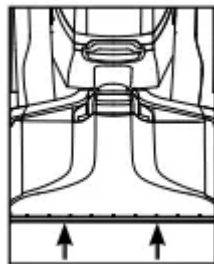

How to Change and Clean Brushes

HOW TO REMOVE

1 To prevent possible leaking, remove Clean Water Tank, Dirty Water Tank and Solution Tank



2 With handle in upright position, follow “Nozzle: How to Remove and Clean” instructions.

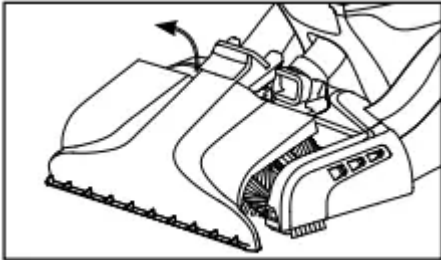

3 Grab Side A and pull up to remove. Repeat on the other brush.

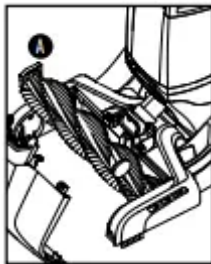

4 The brushes can be cleaned under running water.

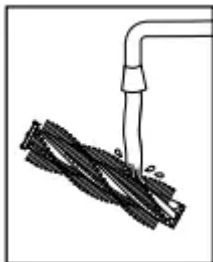

HOW TO REPLACE

1 At an angle, align side B on the brush to the drive gear.

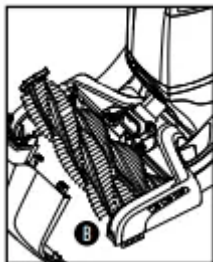

2 Press Tab A down until brush snaps in place.

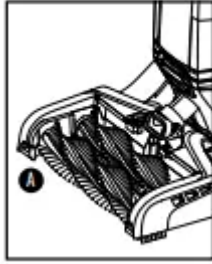

STORAGE

Before storing: Empty Clean Water Tank and let air dry. Replace on cleaner. Empty Dirty Water Tank, rinse tank and lid thoroughly with clean water and let air dry. Empty Solution Tank, rinse tank with clean water.

Allow brushes and underside of carpet cleaner to air dry thoroughly before storing carpet cleaner on a carpeted or wood surface.

LUBRICATION

The motor is equipped with bearings that contain sufficient lubrication for the life of the motor. The addition of lubricant could cause damage. Therefore, do not add lubricant to motor bearings or brushrolls.

Tools and Accessories

HOW TO ATTACH HOSE

1 Open Hose Connection Port. Insert hose end by inserting **FIRMLY** into Hose Solution Port

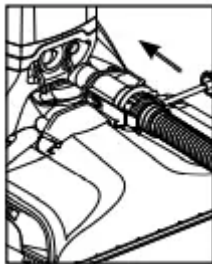

HOW TO REMOVE HOSE

1 Press trigger on tool to ensure all fluid has discharged from the hose. Press button on end of hose and pull to remove hose and solution connection from unit.

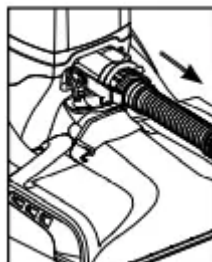

2 Close the Hose Port Door back into place. Make sure to close door to ensure proper suction. Unit may lose suction if not closed properly.



How to Attach Tools

1 To ensure maximum performance and to protect your carpet, be sure to place the handle in the upright position while using the hose. Placing the handle in the upright position shuts off the FlexForce™ PowerBrushes



2 Connect tool to hose by sliding it onto the connector until it securely locks into place.



3 Using your thumb, push forward and up on the latch to remove tool.

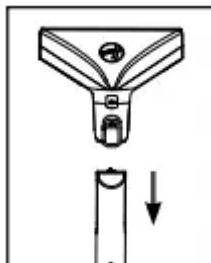

NOTE: Do not place unit at top of stairway to avoid falling down stairs. Place unit at bottom of stairs and work up.

Cleaning Carpeted Stairs and Upholstery

1. Read “Before you Begin Cleaning” instruction
2. Attach hose as instructed
3. Place handle in upright position. FlexForce™ PowerBrushes will not rotate while handle is in upright position.
4. Fill Clean Water Tank according to instructions.
5. Fill Solution Tank with Hoover® solution according to instructions.
6. Attach tool to end of hose.
7. Dry hands and plug cleaner into a properly grounded outlet.
8. Turn cleaner ON.
9. Pre-spray the area by holding the tool about one inch above the carpet and push it forward while pressing the trigger
10. Slightly press the tool it into area cleaning. Press the trigger and pull the tool slowly over the carpet. Release trigger at end of stroke.
11. Lift tool, and position it against Nozzle. Pull tool slowly over carpet without pressing trigger.
12. Overlap strokes by ½ inch to help prevent streaking.
13. It is best to alternate wet and dry strokes as described in steps.

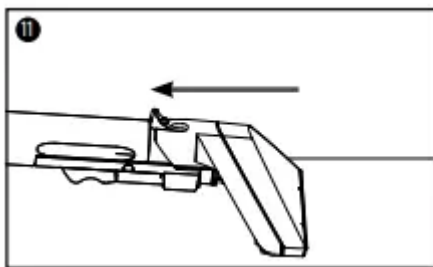
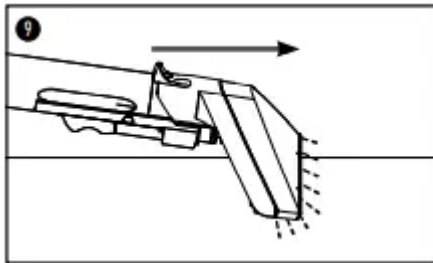

Tips

To avoid saturating carpet, do not use more than 4 wet strokes over any one area. Always end with dry strokes.

If additional cleaning is necessary, wait until the carpet is completely dry before using the tool again.

Empty Dirty Water Tank when the motor sound becomes higher pitched and there is a loss of suction. You will also see the float rise and shut off suction at the same time.

When finished cleaning, follow “after Cleaning” and “After Using Tool” instructions.

Hoover® Cleaning Solution Guide

Use only Hoover cleaning solutions to prevent potential harm to your carpet cleaner and keep your warranty.

For best results, use your Carpet Cleaner + Spot Treatment + Solutions.

Hoover has a full line of Detergents and Spot Treatments to complement your Hoover carpet cleaner and the specific condition of your carpet. To prevent project interruption, keep Detergent on hand and store with your carpet cleaner. Spot Treatment may be used as a pretreatment immediately before you clean your carpets, or as an independent treatment between cleaning your carpets.

EXPERT CARPET SOLUTIONS: PROFESSIONAL GRADE

EXPERT CLEAN™ CARPET WASHER DETERGENT - Powerful, professional strength cleaner lifts dirt and removes allergens for our deepest, extreme clean



EXPERT CLEAN™ SPOT TREATMENT GEL - Professional grade targeted gel removes tough stains like ground-in dirt, allergens, chocolate and wine.



EXPERT PET™ CARPET WASHER DETERGENT - Powerful, professional strength enzymes break down biological stains, dirt and odor for a truly deep clean



EXPERT PET™ SPOT TREATMENT SPRAY - Professional grade targeted enzyme spray removes tough stains like dirt, oils, urine and residual odor.



PLUS CARPET SOLUTIONS

CLEAN PLUS™ CARPET WASHER DETERGENT - Powerful cleaner for everyday dirt and grime.



CLEAN PLUS™ SPOT SPRAY - Powerful spot spray for everyday dirt and grime.



PET PLUS™ CARPET WASHER DETERGENT - Powerful cleaner enhanced with enzymes to tackle pet messes and eliminate odor.



PET PLUS™ SPOT SPRAY - Powerful spot spray enhanced with enzymes to tackle pet messes and eliminate odor



PRO PLUS™ CARPET WASHER DETERGENT - Professional strength carpet & upholstery solution removes stubborn stains and odors



HARD FLOOR SOLUTIONS

MULTI-FLOOR PLUS™ HARD FLOOR SOLUTION - Powerful hard floor cleaning solution removes everyday dirt and grime.



TILE & GROUT PLUS™ HARD FLOOR SOLUTION - Powerful hard floor cleaning solution cleans and revitalizes tile and grout surfaces



STEAM PLUS™ HARD FLOOR SOLUTION - Powerful hard floor cleaning solution combines with steam to safely wash hard floors.



Troubleshooting:

Any other servicing should be done by an authorized service representative.

USE TROUBLESHOOTING GUIDE AS A FIRST STEP TO RESOLVE ANY PROBLEMS YOU MAY BE EXPERIENCING.

If appliance is not working as it should, has been dropped, damaged, left outdoors, or dropped into water, call Customer Service at 1-800-944-9200 for further instruction before continuing use

Cleaner won't run

1. Not firmly plugged in
 - Plug unit in firmly.
2. No voltage in wall plug
 - Check fuse or breaker in home.
3. Blown fuse or tripped breaker
 - Replace fuse or reset breaker in home.

4. Fuse in cleaner blown
 - Take to service center.
5. On/Off pedal not depressed
 - Press pedal.

Low suction

1. Dirty Water Tank full/automatic shut off engaged
 - Remove and empty Dirty Water Tank. See "How to Empty"
2. Blockage in tool on end of hose
 - Remove tool and clear blockage.
3. Dirty Water Lid not on correctly
 - Make sure lid is on securely. See "How to Clean"
4. Dirty Water Tank Debris Filter clogged
 - See "How to Clean"
5. Blockage in nozzle
 - See "How to Clean"
6. Recovery Tank not properly secured
 - Replace Recovery Tank and secure recovery tank latch.
7. Recovery Nozzle not on correctly
 - Remove and replace Recovery Nozzle. See "How to Clean & Remove Nozzle"
8. Blockage in hose
 - Drop a coin through, clear with broom handle.

Hose Nozzle stops spraying liquid during use

1. Clean Water Tank or Detergent Container is empty
 - Turn off Cleaner and fill Clean Water tank & Detergent Container.
2. Loose connection to solution port on foot of cleaner
 - Check for secure connection to solution port on foot of Cleaner.

Accessory Tool will not spray after filling the Clean Water Tank or Solution Tank

1. Air is trapped in the hose & pump
 - Turn on the Cleaner. If hose does not spray, prime the pump by lowering the hose down to the floor and hold the trigger for up to one minute.
 - 2. Aim downward & squeeze trigger.

Hose will not spray after priming pump

1. Pump is defective
 - Call for service: 1-800-944-9200.
2. Not connected properly
 - Check connection.

Clean water won't dispense

1. Clean Water Tank or Solution Tank not firmly in place
 - Make sure tank is securely locked in position.
2. Clean Water Tank or Solution Tank empty
 - Refill container according to cleaning instructions.

Solution won't dispense

1. Unit is not moving in forward direction
 - Ensure unit is moving in forward direction.

Brushes won't rotate during floor cleaning

1. Brushroll stall protection activated
 - Turn the unit off and back on, then inspect and clean for jams.
2. Unit in upright position
 - Brushes will not rotate in upright position. Step on handle release to start cleaning.

Water is Leaking out of Carpet Cleaner

1. Clean Water Tank, Solution Tank or Dirty Water Tank not FIRMLY in place
 - Make sure the tank is secure.

Warning

This content is compiled from multiple sources and is provided for reference purposes only. It may not be complete or fully applicable to all situations. If you are unable to resolve your issue, please contact the product manufacturer or an authorized service provider for official support.