

TV components

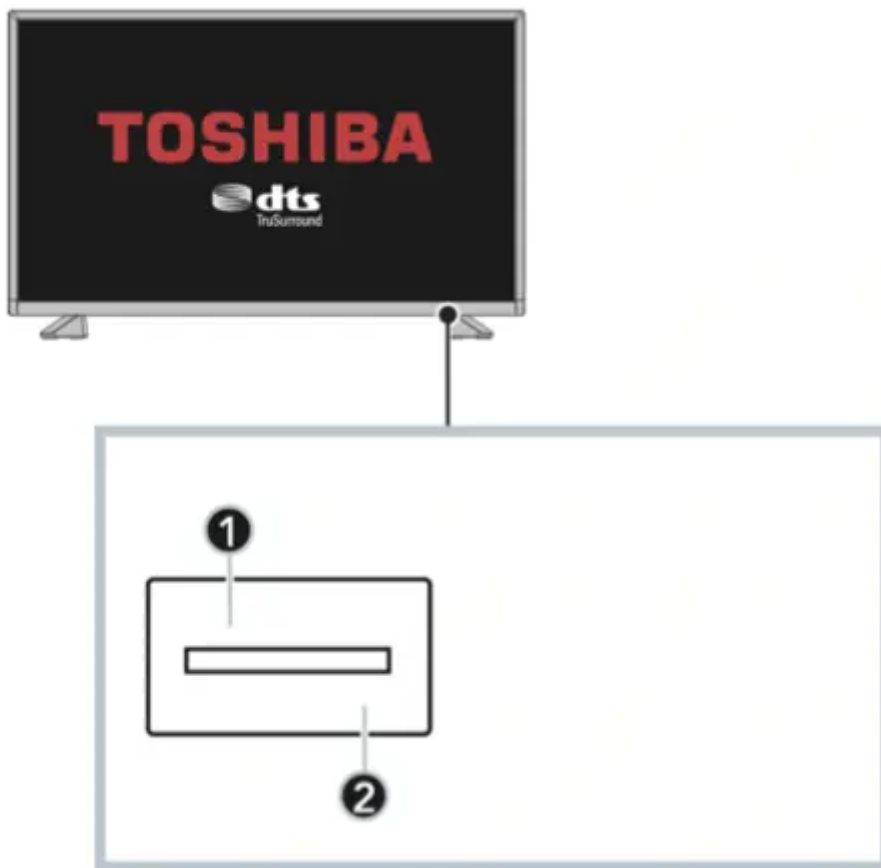

Front

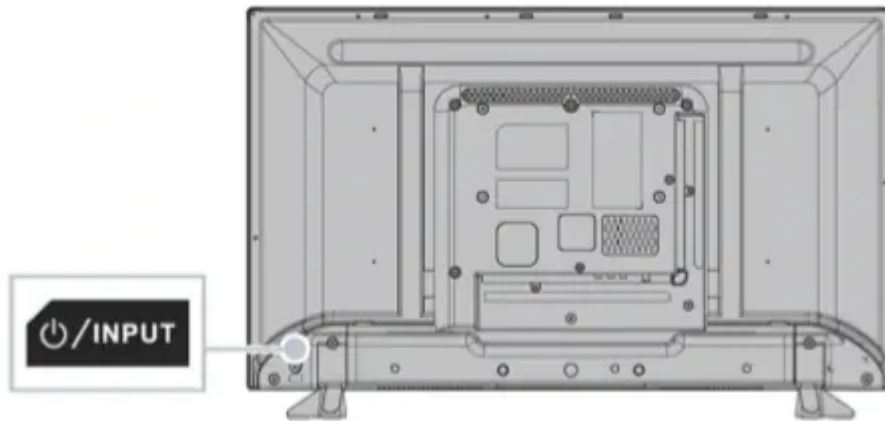

#	Item	Description
1	Remote control sensor	Receives signals from the remote control. Do not block.
2	Power indicator	Turns off when your TV is on. Lights red when your TV is off (standby mode).

Power/INPUT button



Item	Description
<p> / INPUT</p>	<p>—Press to turn on your TV when your TV is off (in standby mode). Press and hold to turn off your TV when your TV is on. Warning: When your TV is off, power still flows through it. To completely disconnect power, unplug the power cord.</p> <p>INPUT—When your TV is on, quickly press and release to open the Input Selection list, press one or more times to select a video input source, then wait a few seconds. Your TV switches to the source you selected. For more information, see Selecting the video input source on page 40.</p>

Side jacks

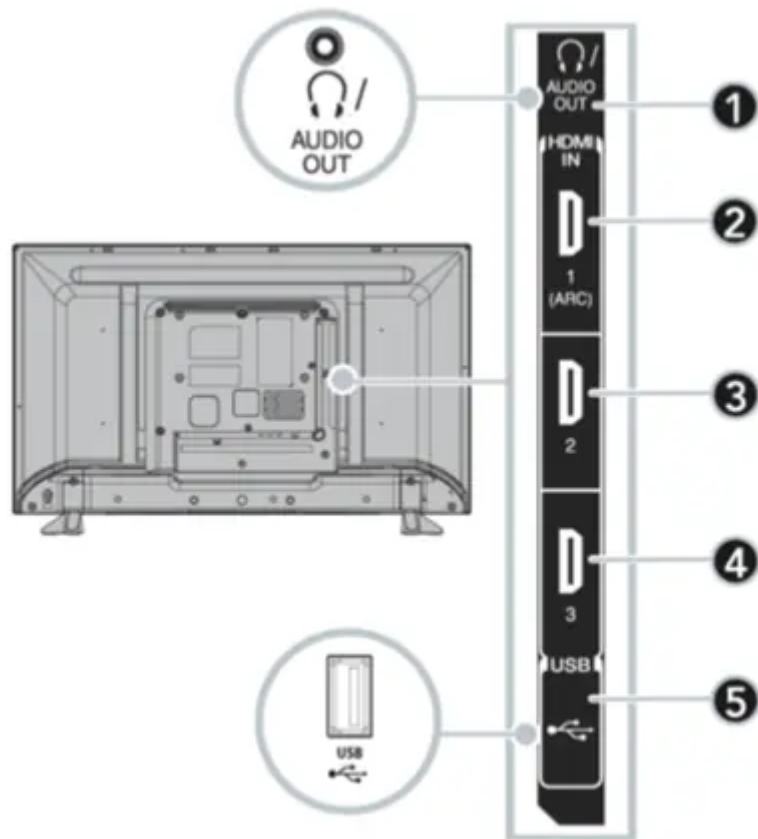

#	Item	Description
1	 / AUDIO OUT	<p>Connect headphones to this jack. See Connecting headphones on page 31.</p> <p>OR Connect an analog soundbar, speaker system, or home theater system to this jack to listen to TV audio through external speakers. For more information, see Analog audio on page 33.</p>
2	HDMI IN 1 (ARC)	<p>Connect an HDMI device to this jack. For more information, see HDMI (best) on page 19, 24, 26, or 28.</p> <p>OR Connect an ARC-enabled home theater receiver to this jack.</p>
3	HDMI IN 2	<p>Connect an HDMI device to this jack. For more information, see HDMI (best) on page 19, 24, 26, or 28.</p>
4	HDMI IN 3	<p>49" and 55" models Connect an HDMI device to this jack. For more information, see HDMI (best) on page 19, 24, 26, or 28.</p>
5	USB	<p>Connect a USB flash drive to this jack to view compatible JPEG picture files. For more information, see Connecting a USB flash drive on page 30 and Viewing photos on a USB flash drive on page 47.</p>

Back jacks

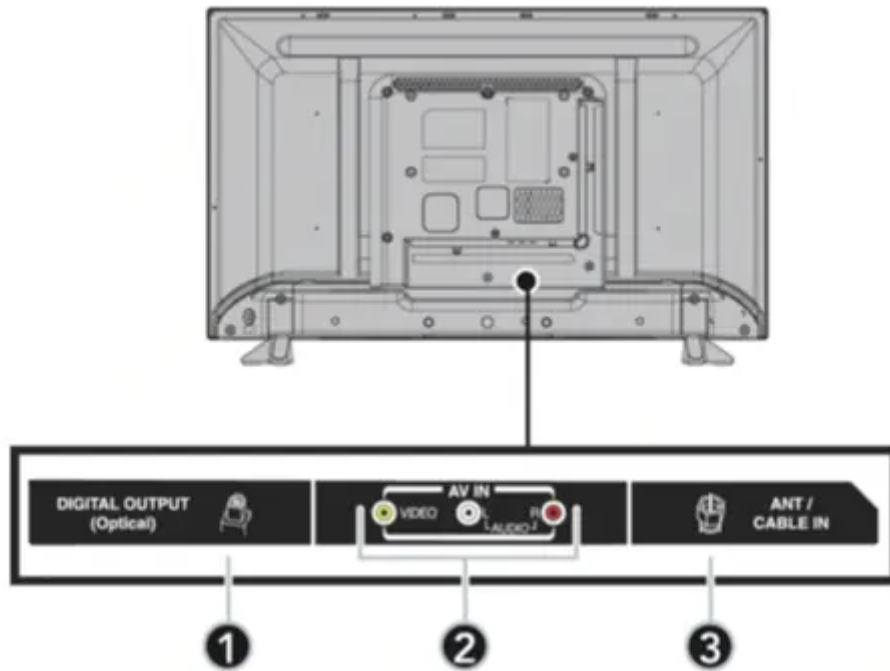



#	Item	Description
1	DIGITAL OUTPUT (Optical)	Connect a soundbar, digital speaker system, or home theater system to this jack to listen to TV audio through external speakers. For more information, see Connecting external speakers or a soundbar on page 32.
2	VIDEO and AUDIO L and R	Connect the video and audio for an AV device to this jack. For more information, see AV (good) on page 21, 25, or 27.
3	ANT/CABLE IN	Connect an antenna or cable TV to this jack. For more information, see Coaxial (good) on page 22 or Connecting an antenna or cable TV (no box) on page 23.

Remote control



Button	Press to...
INPUT	Open the Input Selection list. Press ▲ or ▼ to select the video input source, then press ENTER. See Selecting the video input source on page 40.
SLEEP	Set the sleep timer. You can select 5, 10, 15, 30, 60, 90, 120, 150, 180, and 240 min. See Setting the sleep timer on page 66.
FREEZE	Freeze the picture. Press again to un-freeze the picture. See Freezing the picture on page 54.
Numbers	Enter channel numbers and PINs.
—	Enter a digital sub-channel number. See Selecting a channel on page 43.

MUTE	Mute the sound or un-mute the sound. See Adjusting the volume on page 43.
VOL+/-	Increase or decrease the volume.
	TV—Navigate in on-screen TV menus and to adjust settings. USB—Control a photo slideshow.
MENU	Open the on-screen menu.
BACK	Return to the previous menu level.
INFO	Display TV status information, such as the channel number, channel name (if available), or signal source. See Viewing channel information on page 43.
 (power)	Turn your TV on or off (standby mode). When your TV is off, the power indicator lights red. Warning: When your TV is off, power still flows through it. To disconnect power, unplug the power cord.
PIC SIZE	Change how the picture looks on the screen (aspect ratio). See Adjusting the picture size on page 51.
PIC MODE	Select the picture mode. You can select Dynamic, Standard, Natural, Movie, Game, or PC. See the Picture Mode option in Adjusting the TV picture on page 49.
FAV	Open the Favorite channel list. See Setting up the Favorites list on page 58 and Tuning to a favorite channel on page 58.
SAP	Select a secondary audio program, if available
CH▲/CH▼	Change TV channels. See Selecting a channel on page 43.
ACC	Open the Accessibility menu. See Adjusting accessibility settings on page 49.

ENTER	Confirm selections or changes in on-screen menus.
EXIT	Close the on-screen TV menu.
C.CAPTION	Turn closed captioning on or off. Select the language (like English) to turn on closed captioning or Off to turn off closed captioning. See Turning closed captioning on or off on page 63.
CH RTN	Return to the previous channel or source.
Media Controls	Control HDMI CEC-compatible devices. See Controlling CEC-compatible devices on page 44.

What connection should I use?

Your TV has several connection types for connecting devices to your TV.

For the best video quality, you should connect a device to the best available connection.

Use the following tables to identify cables:

Video quality	Connection type and jack	Cable connector
----------------------	---------------------------------	------------------------

Best (use this if your devices have HDMI)

HDMI video/audio



Good

AV (requires an audio connection)



Good

Coaxial video/audio



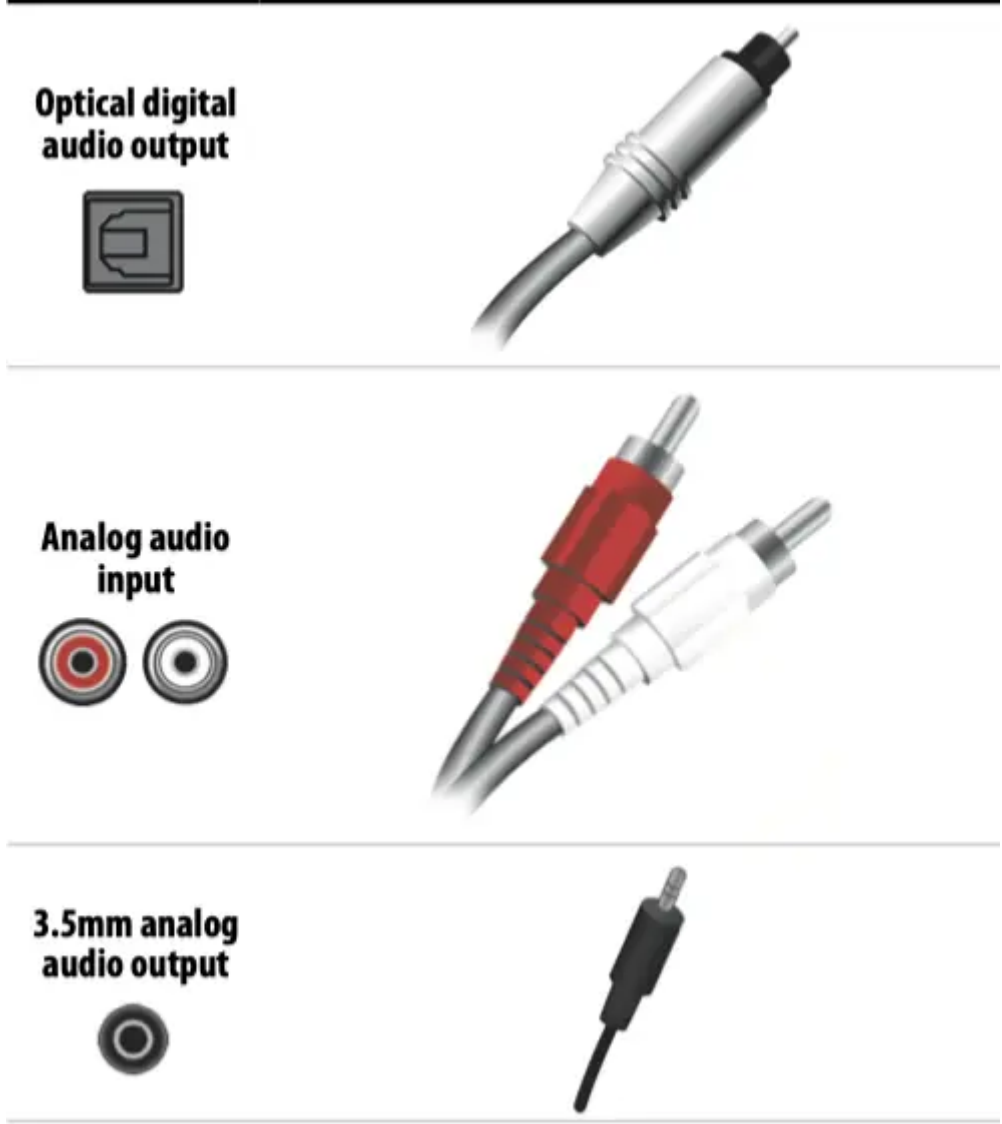

You can use an HDMI IN jack on your TV to connect a DVI device to your TV. For more information, see DVI (same as HDMI but requires an audio connection) on page 20 or 29.

Cautions

- Check the jacks for position and type before making any connections.
- Loose connections can cause poor audio or video quality. Make sure that all connections are tight and secure.
- The external audio/video equipment shown may be different from your equipment. If you have questions, refer to the documentation that came with your equipment.
- Always unplug the power cord when connecting external equipment.

Connecting a cable or satellite box

Many cable or satellite TV boxes have more than one connection type. To get the best video, you should use the best connection type available. For more information, see What connection should I use? on page 18.



HDMI (best)

Note

The 32" model does not have an HDMI IN 3 jack.

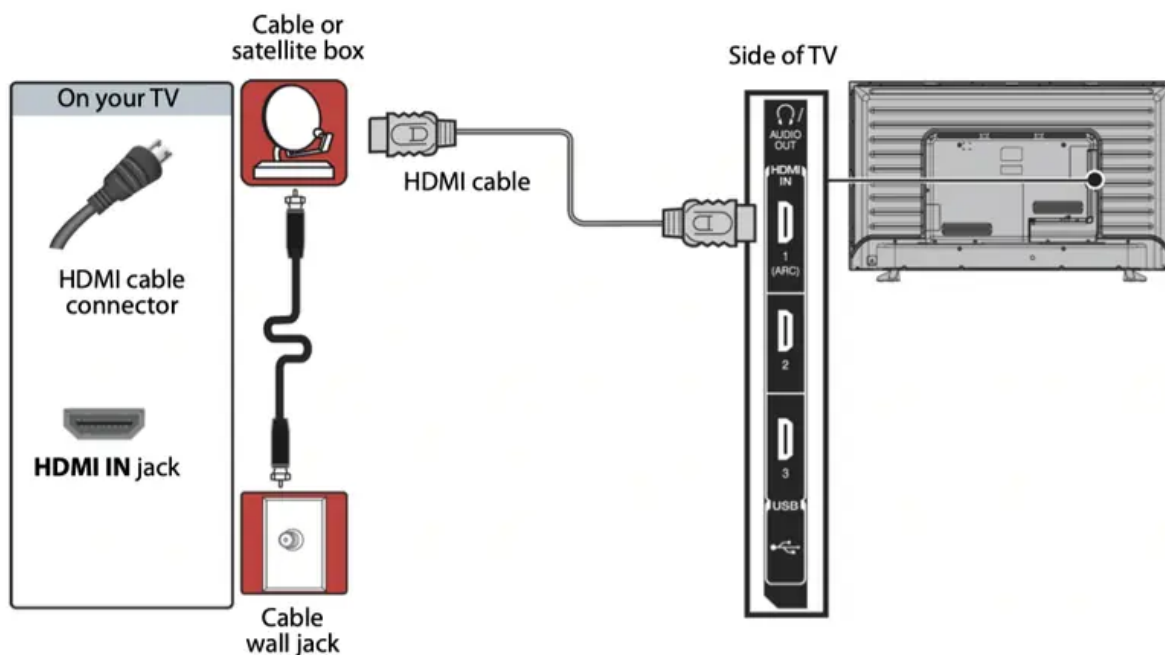

1. Make sure that your TV's power cord is unplugged and all connected equipment is turned off.
2. Connect the incoming cable from the cable wall jack to the cable-in jack on the cable or satellite box.
3. Connect an HDMI cable (not provided) to one of the HDMI IN jacks on the side of your TV and to the HDMI OUT jack on the cable or satellite box.
4. Plug your TV's power cord into a power outlet, turn on your TV, then turn on the cable or satellite box.
5. Press INPUT to open the Input Selection list.
6. Press ▲ or ▼ to highlight HDMI 1, HDMI 2, or HDMI 3, then press ENTER.

Notes

- An HDMI cable carries both audio and video. You do not need to use any audio cables.
- The 32" model does not have the HDMI 3 option.

DVI (same as HDMI but requires an audio connection)

Note

- Your TV supports DVI video only. To add sound for a DVI connection, connect external speakers or a soundbar to the cable or satellite box.

- The 32" model does not have an HDMI IN 3 jack.

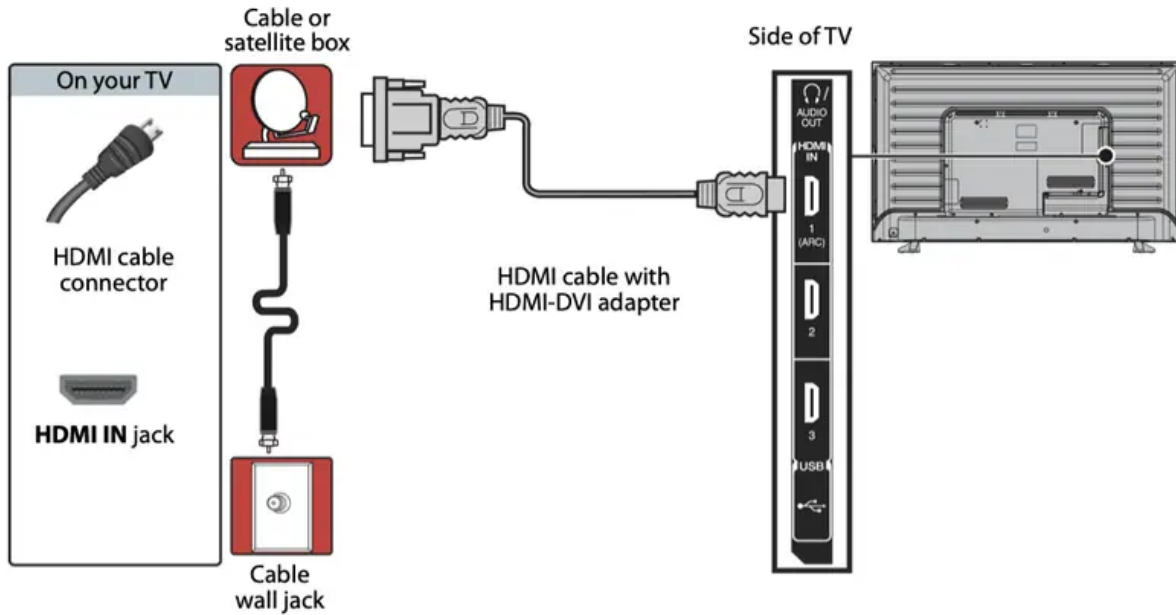

1. Make sure that your TV's power cord is unplugged and all connected equipment is turned off.
2. Connect the incoming cable from the cable wall jack to the cable-in jack on the cable or satellite box.
3. Connect an HDMI-DVI adapter (not provided) to one end of an HDMI cable (not provided), then connect the adapter to the DVI OUT jack on the cable or satellite box.
4. Connect the other end of the cable to one of the HDMI IN jacks on the side of your TV.
5. Plug your TV's power cord into a power outlet, turn on your TV, then turn on the cable or satellite box.
6. Press INPUT to open the Input Selection list.
7. Press ▲ or ▼ to highlight HDMI 1, HDMI 2, or HDMI 3, then press ENTER.

Note

The 32" model does not have the HDMI 3 option.

AV (good)

Notes

Cables are often color-coded to match color-coded jacks.



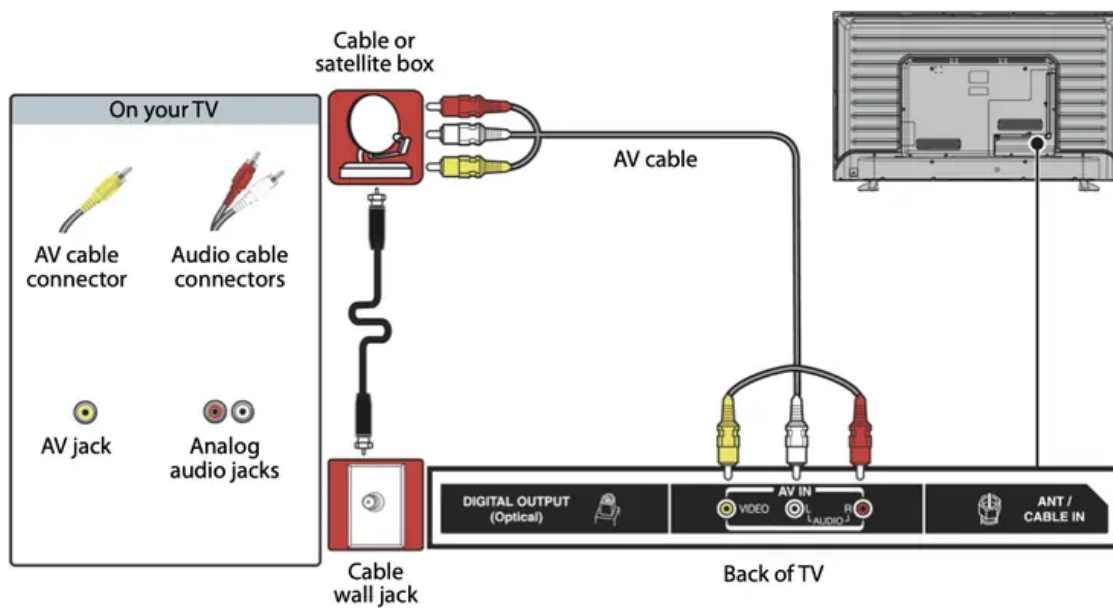

1. Make sure that your TV's power cord is unplugged and all connected equipment is turned off.
2. Connect the incoming cable from the cable wall jack to the cable-in jack on the cable or satellite box.
3. Connect an AV cable (not provided) to the VIDEO jack and AUDIO L and R jacks on the back of your TV and to the AV and audio out jacks on the cable or satellite box.

Important

When you connect the audio using the AUDIO L and R jacks, the audio output is analog.

4. Plug your TV's power cord into a power outlet, turn on your TV, then turn on the cable or satellite box.
5. Press INPUT to open the Input Selection list.
6. Press ▲ or ▼ to highlight AV, then press ENTER.

Coaxial (good)

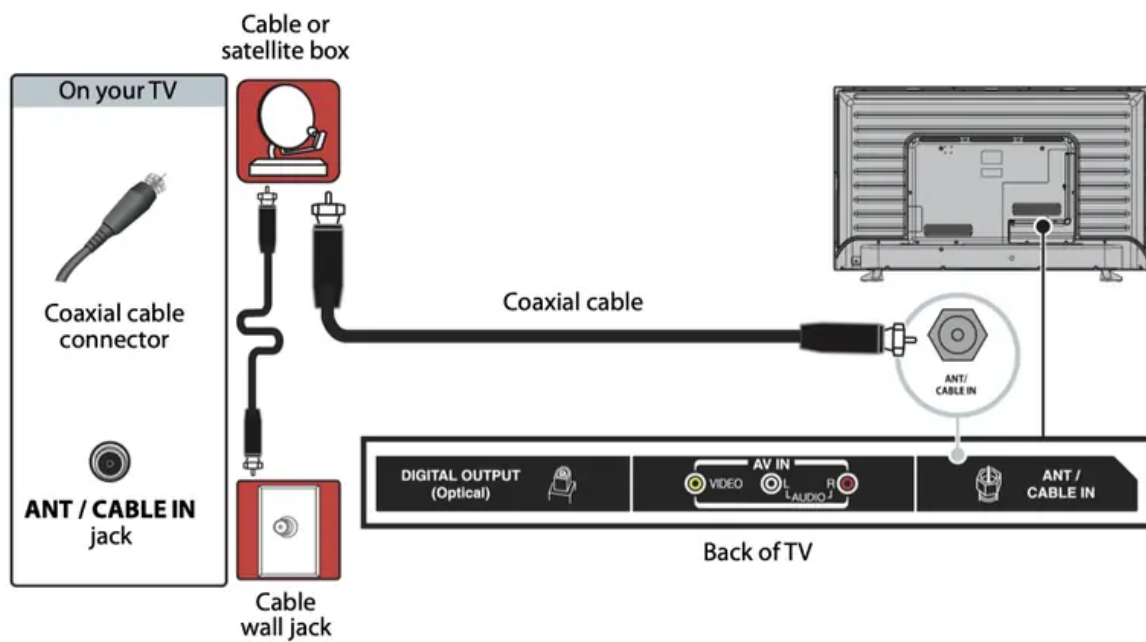

1. Make sure that your TV's power cord is unplugged and all connected equipment is turned off.
2. Connect the incoming cable from the cable wall jack to the cable-in jack on the cable or satellite box.
3. Connect a coaxial cable (not provided) to the ANT / CABLE IN jack on the back of your TV and to the coaxial out jack on the cable or satellite box.
4. Plug your TV's power cord into a power outlet, turn on your TV, then turn on the cable or satellite box.
5. Press INPUT to open the Input Selection list.
6. Press ▲ or ▼ to highlight ANT / CABLE, then press ENTER.
7. If you cannot tune to channels you know exist, scan for channels. See Automatically scanning for channels on page 56.

Notes

- Use a coaxial cable to eliminate interference and noise from radio waves.
- Do not bundle the coaxial cable with the power cord or other cables.

Connecting an antenna or cable TV (no box)

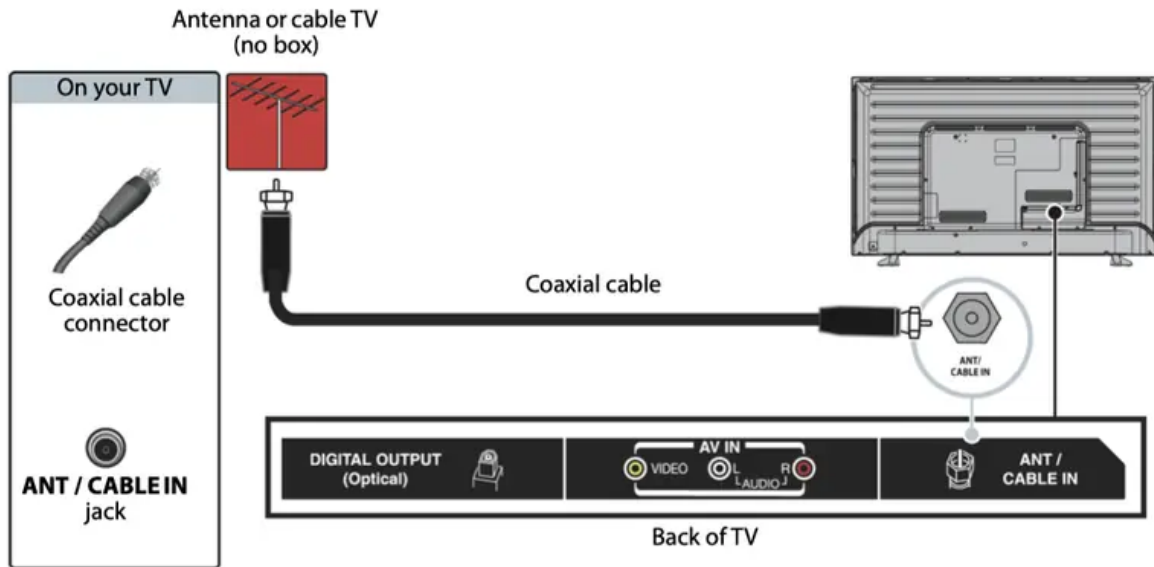

1. Make sure that your TV's power cord is unplugged and all connected equipment is turned off.
2. Connect a coaxial cable (not provided) to the ANT / CABLE IN jack on the back of your TV and to the antenna or cable TV wall jack.
3. Plug your TV's power cord into a power outlet, then turn on your TV.
4. Press INPUT to open the Input Selection list.
5. Press ▲ or ▼ to highlight ANT / CABLE, then press ENTER.
6. If you cannot tune to channels you know exist, scan for channels. See Automatically scanning for channels on page 56.

Notes

- Use a coaxial cable to eliminate interference and noise from radio waves.
- Do not bundle the coaxial cable with the power cord or other cables.
- If the antenna is not installed correctly, contact qualified service personnel to correct the problem.
- If the signal level for a channel is weak, the picture may be distorted. Adjust the antenna or use a highly directional outdoor or set-top antenna with a built-in amplifier.
- If the picture quality is good on some channels and poor on others, the problem may be caused by a poor or weak signal from the broadcaster or cable TV provider.
- If you connect to cable TV without a set-top box and experience poor picture quality, you may need to install a set-top box to improve signal reception and picture quality. Contact your cable TV provider about upgrading to a set-top box.

- Many high-definition (HD) channels upscale standard-definition (SD) content. The picture displayed on your TV is still displayed as SD, thus the picture quality will not be as clear or crisp as it would be if the content was originally recorded in HD.

Connecting a DVD or Blu-ray player

Many DVD or Blu-ray players have more than one connection type. To get the best video, you should use the best connection type available. For more information, see What connection should I use? on page 18.

HDMI (best)

Note

The 32" model does not have an HDMI IN 3 jack.

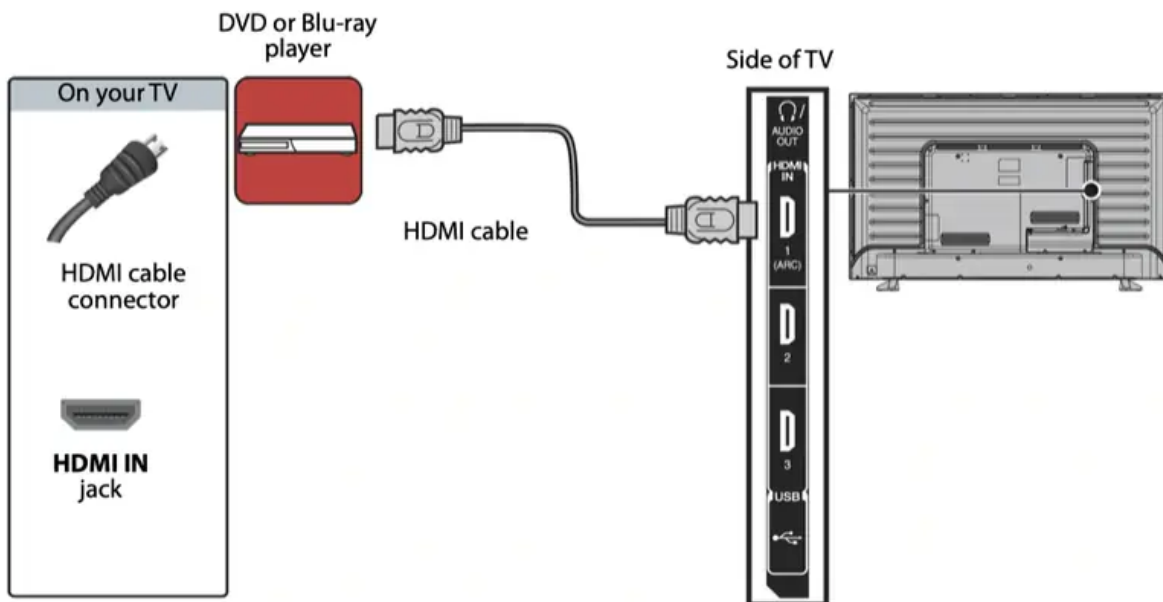

1. Make sure that your TV's power cord is unplugged and the DVD or Blu-ray player is turned off.
2. Connect an HDMI cable (not provided) to one of the HDMI IN jacks on the side of your TV and to the HDMI OUT jack on the DVD or Blu-ray player.
3. Plug your TV's power cord into a power outlet, then turn on your TV and DVD or Blu-ray player.
4. Press INPUT to open the Input Selection list.
5. Press ▲ or ▼ to highlight HDMI 1, HDMI 2, or HDMI 3, then press ENTER.

Notes

- An HDMI cable carries both audio and video. You do not need to use any audio cables.
- The 32" model does not have the HDMI 3 option.

AV (good)

Note

Cables are often color-coded to match color-coded jacks.

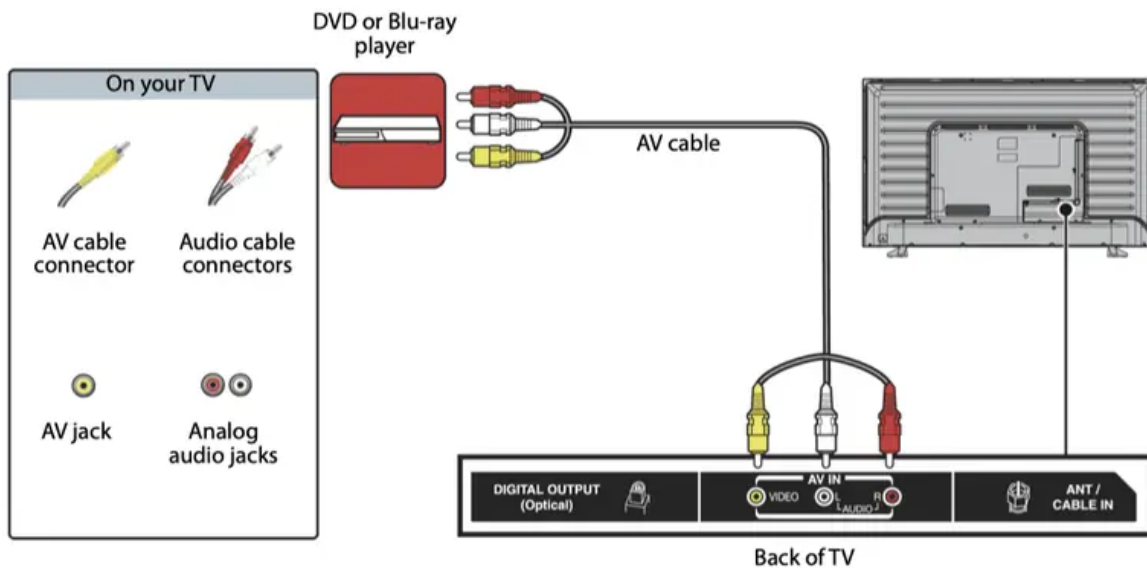

1. Make sure that your TV's power cord is unplugged and the DVD or Blu-ray player is turned off.
2. Connect an AV cable (not provided) to the VIDEO jack and AUDIO L and R jacks on the back of your TV and to the AV OUT jacks on the DVD or Blu-ray player.

Important

When you connect the audio using the AUDIO L and R jacks, the audio output is analog.

3. Plug your TV's power cord into a power outlet, then turn on your TV and DVD or Blu-ray player.
4. Press INPUT to open the Input Selection list.
5. Press ▲ or ▼ to highlight AV, then press ENTER.

Connecting a game console

HDMI (best)

Note

The 32" model does not have the HDMI IN 3 jack.

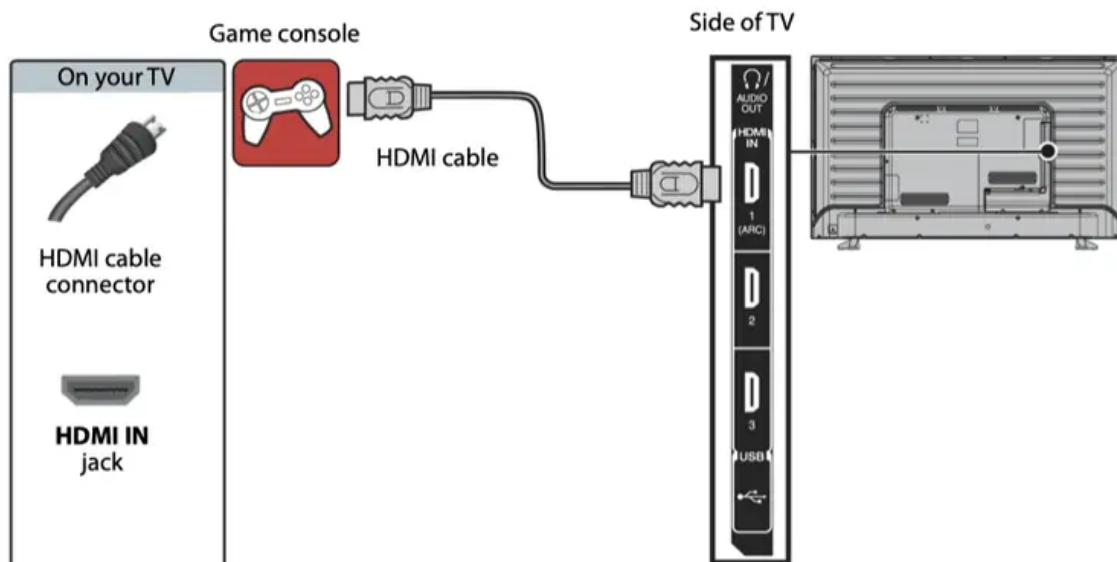

1. Make sure that your TV's power cord is unplugged and the game console is turned off.
2. Connect an HDMI cable (not provided) to one of the HDMI IN jacks on the side of your TV and to the HDMI OUT jack on the game console.
3. Plug your TV's power cord into a power outlet, then turn on your TV.
4. Turn on the game console, then set it to the correct output mode. For more information, see the documentation that came with the console.
5. Press INPUT to open the Input Selection list.
6. Press ▲ or ▼ to highlight HDMI 1, HDMI 2, or HDMI 3, then press ENTER.

Note

- An HDMI cable carries both audio and video. You do not need to use any audio cables.
- The 32" model does not have the HDMI 3 option.

AV (good)

Notes

Cables are often color-coded to match color-coded jacks.

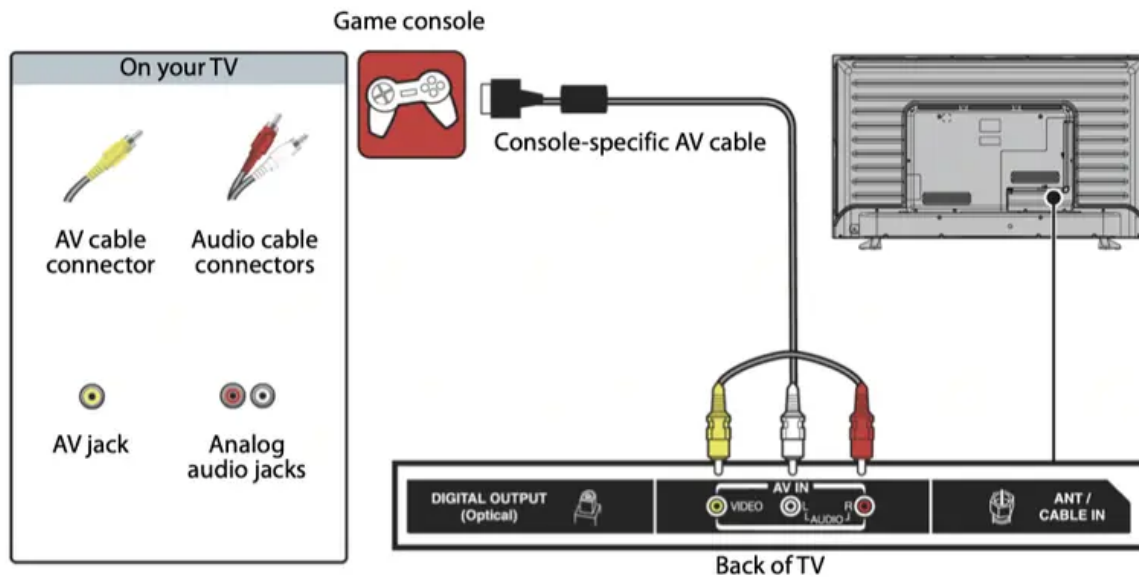

1. Make sure that your TV's power cord is unplugged and the game console is turned off.
2. Connect the video and audio connectors on the game console's AV cable (not provided) to the VIDEO jack and AUDIO L and R jacks on the back of your TV and to the composite jack(s) on the game console.

Important

- Some older game consoles come with a special AV cable. See the documentation that came with your game console or check the manufacturer's website.
 - When you connect the audio using the AUDIO L and R jacks, the audio output is analog.
3. Plug your TV's power cord into a power outlet, then turn on your TV.
 4. Turn on the game console, then set it to the correct output mode. For more information, see the documentation that came with the console.
 5. Press INPUT to open the Input Selection list.
 6. Press ▲ or ▼ to highlight AV, then press ENTER.

Connecting a computer

HDMI (best)

Note

The 32" model does not have the HDMI IN 3 jack.

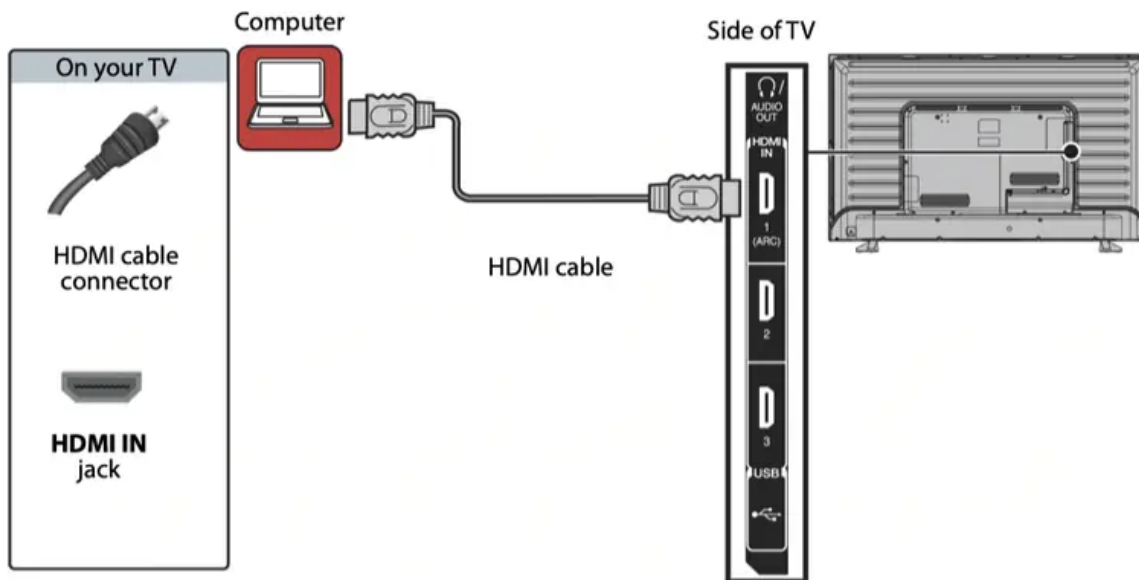

1. Make sure that your TV's power cord is unplugged and the computer is turned off.
2. Connect an HDMI cable (not provided) to one of the HDMI IN jacks on the side of your TV and to the HDMI OUT jack on the computer.
3. Plug your TV's power cord into a power outlet, then turn on your TV and the computer.
4. Press INPUT to open the Input Selection list.
5. Press ▲ or ▼ to highlight HDMI 1, HDMI 2, or HDMI 3, then press ENTER.

Note

The 32" model does not have the HDMI 3 option.

6. Adjust the display properties on the computer, if necessary.

DVI (same as HDMI but requires an audio connection)

Notes

- Your TV supports DVI video only. To add sound for a DVI connection, connect external speakers or a soundbar to the computer.
- The 32" model does not have an HDMI IN 3 jack.



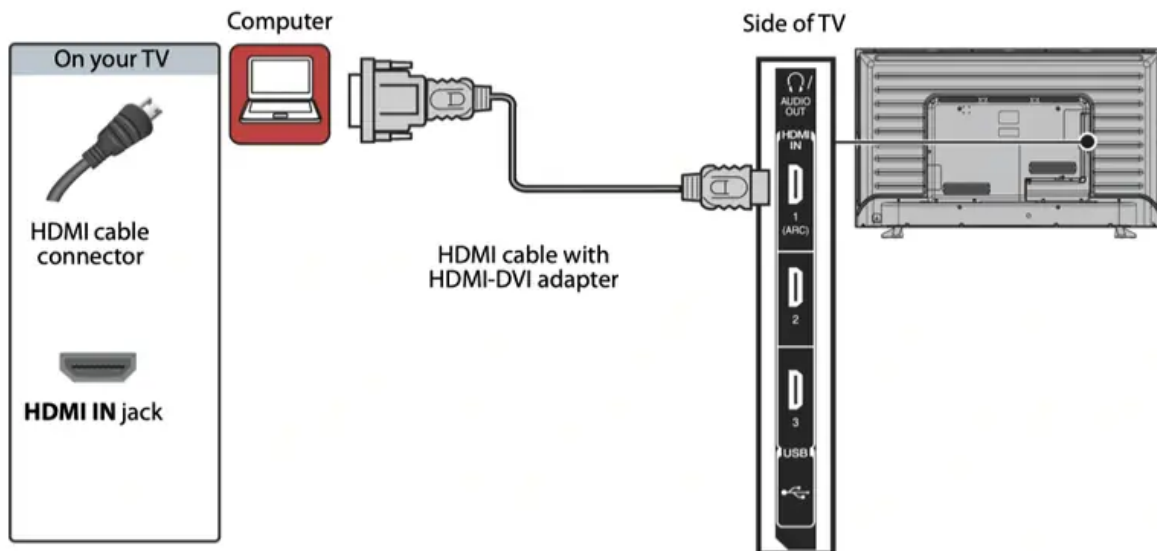

1. Make sure that your TV's power cord is unplugged and the computer is turned off.
2. Connect an HDMI-DVI adapter (not provided) to one end of an HDMI cable (not provided), then connect the adapter to the DVI OUT jack on the computer.
3. Connect the other end of the cable to one of the HDMI IN jacks on the side of your TV.
4. Plug your TV's power cord into a power outlet, then turn on your TV and the computer.
5. Press INPUT to open the Input Selection list.
6. Press ▲ or ▼ to highlight HDMI 1, HDMI 2, or HDMI 3, then press ENTER.

Note

The 32" model does not have the HDMI 3 option.

7. Adjust the display properties on the computer, if necessary.

Connecting a USB flash drive

Note

The 32" model does not have an HDMI IN 3 jack.



Side of TV

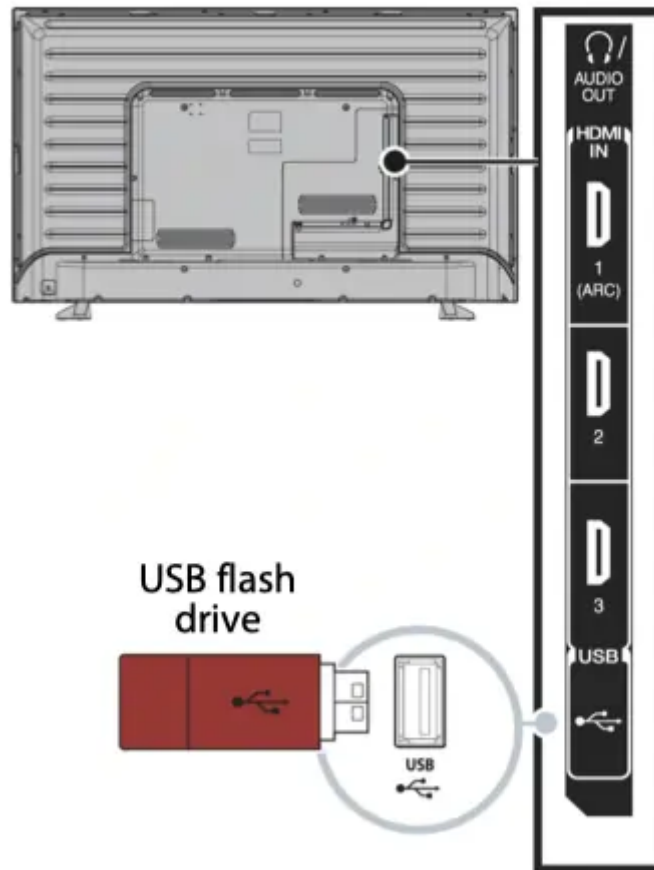

- Plug a USB flash drive into the USB port on the side of your TV.

Caution

Do not remove the USB flash drive or turn off the TV while using the USB flash drive. You may lose data or damage the USB flash drive.

Note

For information about supported file types, see Supported photo file formats on page 47.

Connecting headphones

If the TV Speakers option on the Sound menu is set to Auto or Off, the TV speakers are muted when you connect headphones.

Warning

Loud noise can damage your hearing. When using headphones, use the lowest volume setting on your headphones that still lets you hear the sound.

Note

The 32" model does not have an HDMI IN 3 jack.

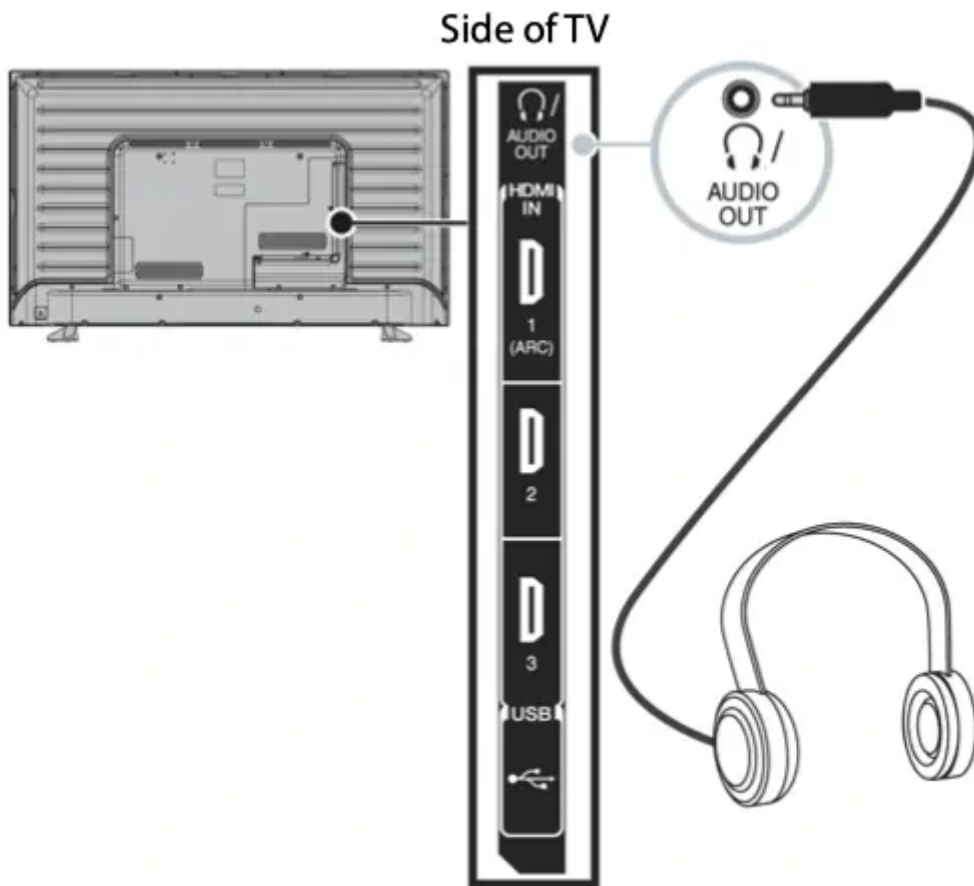

1. Make sure that your TV is turned on, then connect the headphones to the /AUDIO OUT jack on the side of your TV.

2. In the screen that opens, press ◀ or ▶ to highlight Headphones / Audio Out Variable, then press ENTER.

Connecting external speakers or a soundbar

Digital audio

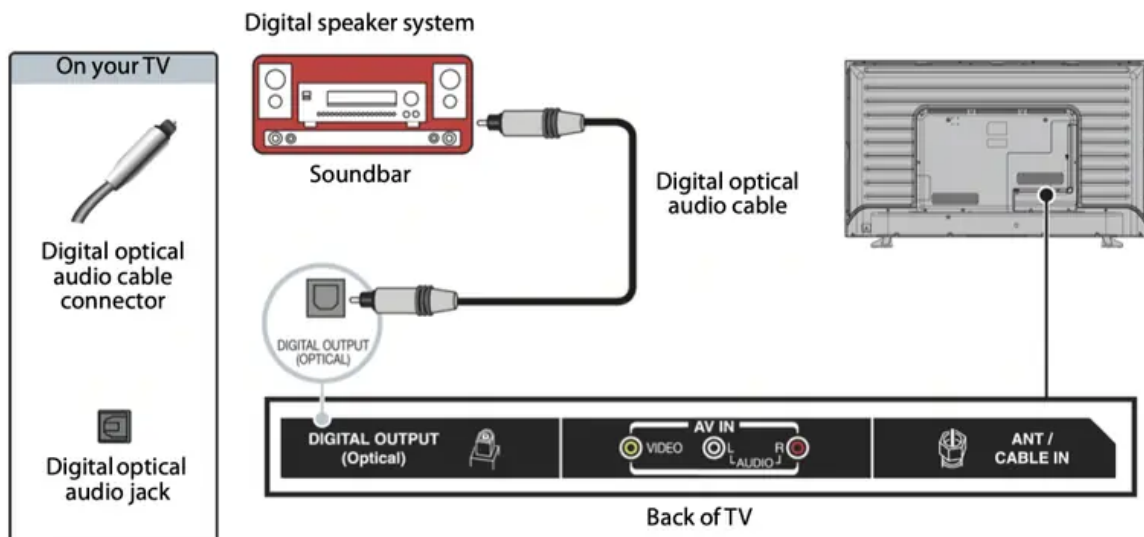

1. Make sure that your TV's power cord is unplugged and the digital speaker system or soundbar is turned off.
2. Connect a digital optical audio cable (not provided) to the DIGITAL OUTPUT (Optical) jack on the back of your TV and to the optical AUDIO IN jack on the digital speaker system or soundbar.
3. Plug your TV's power cord into a power outlet, then turn on your TV.
4. Turn on the digital speaker system or soundbar, then set it to the correct source. For more information, see the documentation that came with the digital speaker system or soundbar.
5. On your TV's Sound menu, highlight Digital Audio Output, then press ENTER. Highlight Audio Format, then press ENTER. Press ▲ or ▼ to select PCM or Auto, then press ENTER. See the Digital Audio Output option in Adjusting sound settings on page 54.

Important

If the Voice Guide is turned on, the TV Speakers option can only be set to Auto and the Audio Format option can only be set to PCM.

Analog audio

Notes

- If the TV Speakers option on the Sound menu is set to Auto or Off, the TV speakers are muted when you connect an analog sound system or soundbar.
- The 32" model does not have an HDMI IN 3 jack.

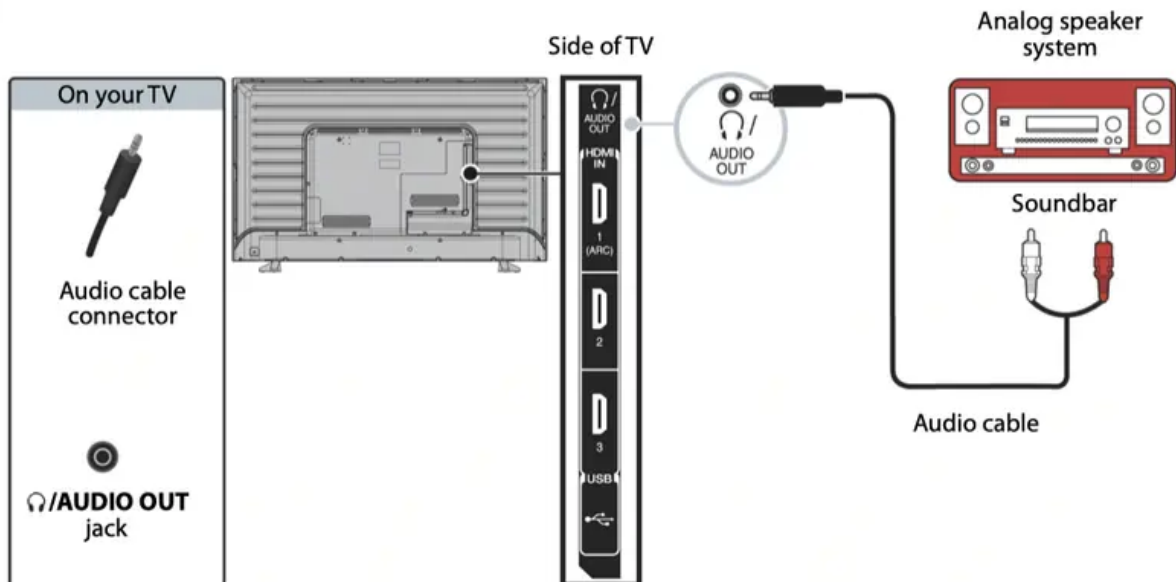

1. Make sure that your TV is turned on and the analog speaker system or soundbar is turned off.
2. Connect an audio cable (not provided) to the /AUDIO OUT jack on the side of your TV and to the AUDIO IN jacks on the analog speaker system or soundbar.

3. In the screen that opens, press ◀ or ▶ to highlight Audio Output Fixed, then press ENTER.

Note

If you want to mute the TV speakers, set the TV Speakers option on the Sound menu to Off or Auto.

4. Turn on the analog speaker system or soundbar, then set it to the correct source. For more information, see the documentation that came with the analog speaker system or soundbar.

Connecting a home theater system with multiple devices

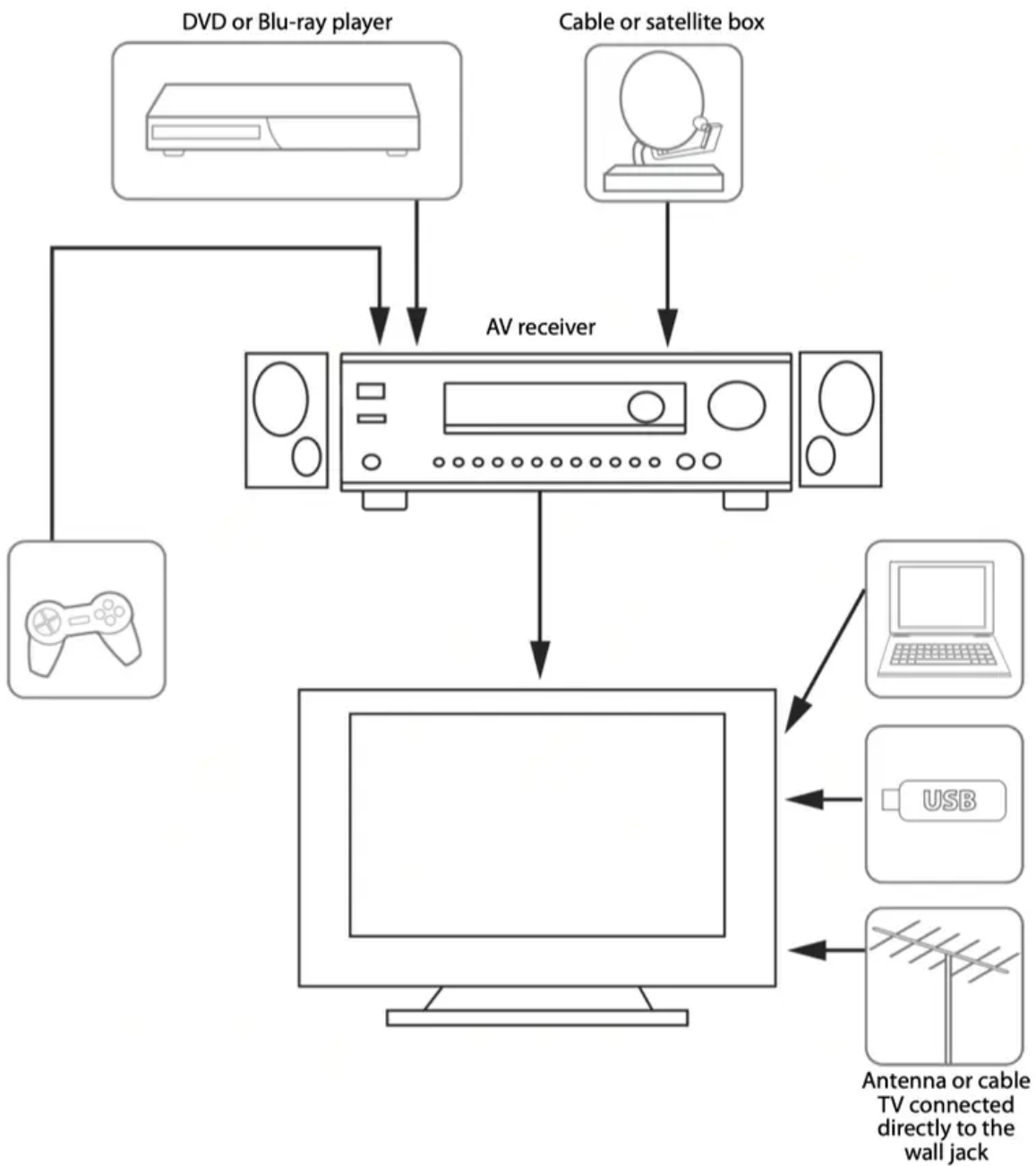

The connections you make depend on the video and audio jacks available on your devices. Refer to the documentation that came with your devices for connection information.

Just remember to use the best connection types available for the best picture and sound. For information about connection types, see *What connection should I use?* on page 18.

Connecting power

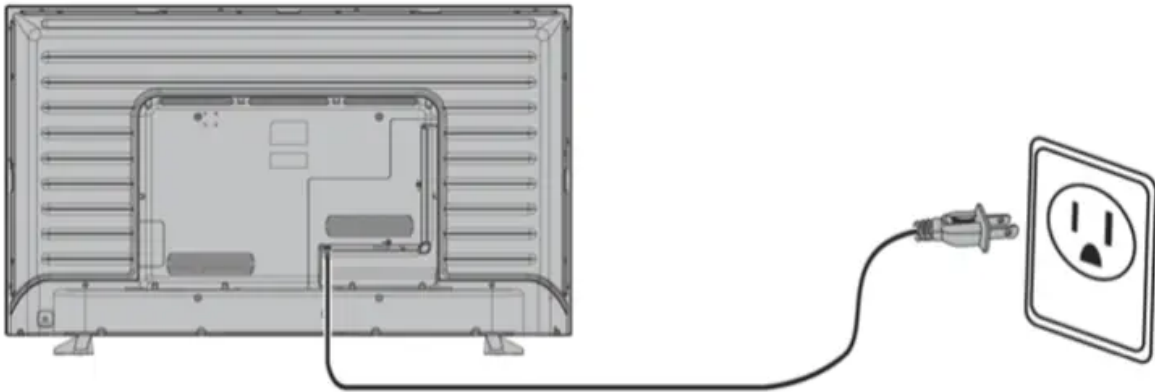

- Connect the power cord to a power outlet.

Cautions

- Your TV should only be operated from the power source indicated on the label.
- Always unplug the power cord from the power outlet when you will not be using your TV for an extended period of time.
- The power cord is permanently attached to your TV. Do not try to unplug it from the back of your TV.

Using the remote control

Installing remote control batteries

1. While squeezing the release latch on the back of the remote control, lift the battery compartment cover off of the remote control.

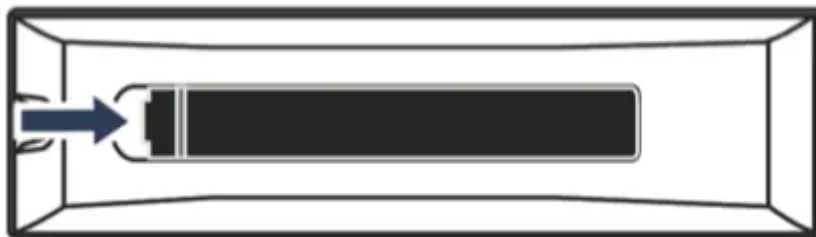

2. Insert two AAA batteries into the battery compartment. Make sure that you match the + and – symbols on the batteries with the + and symbols in the battery compartment.

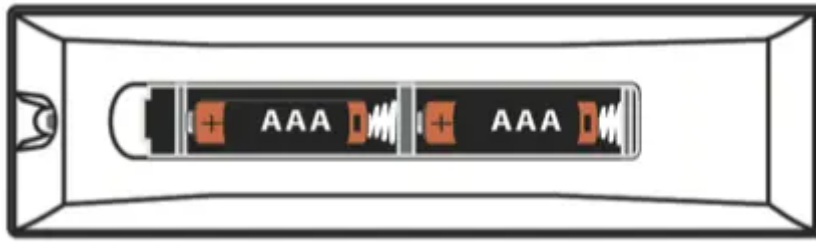

3. Replace the battery compartment cover.

Cautions

- Batteries should not be exposed to excessive heat, such as sunshine, heat registers, or fire.
- Battery chemicals can cause a rash. If the batteries leak, clean the battery compartment with a cloth. If chemicals touch your skin, wash immediately.
- Make sure that batteries are disposed of correctly. Do not burn or incinerate.

Notes

- Do not mix batteries of different types.
- Do not mix old and new batteries.
- Remove batteries when the charge is depleted.
- If the remote control is not going to be used for an extended period of time, remove the batteries.

Aiming the remote control

- Point the remote control towards the remote control sensor on the front of your TV.



Programming universal remote controls

You can operate your Toshiba TV with a new or existing universal remote control.

1. See the table in “Common universal remote control codes” on page 37 for common codes.

If you have problems programming your remote or need a different remote control code:

Contact the universal remote control maker.

OR

Contact the cable or satellite company that provided the remote control you are trying to program.

2. Follow your universal remote control's instructions to enter the TV code you found in Step 1.

Tips

- If your universal remote control has a code search feature, run a code search to identify a code that matches your TV. See your universal remote control's instructions for details.
- If your universal remote control has a “Learn” feature, you can manually program it using the Toshiba TV remote to “teach” the commands one at a time. See your universal remote control's instructions for details.

Common universal remote control codes

The following is a list of the most common remote control codes.

Brand	Remote control codes
AT&T U-verse	1127, 1179, 1203, 1204, 1222, 1223, 1332, 1340, 1341, 1345, 1353, 1010, 1098, 1104, 1147, 1148, 1149, 1150, 1151, 1173, 1174, 1210, 1215, 1256, 1257, 1263, 1267, 1272, 1302, 1311, 1312, 1322, 1343, 1376, 1585, 1589, 1592, 11524, 12724, 10156, 11935, 11704, 11959, 10650, 11343, 11369, 10060
Cablevision	015, 101, 045, 030, 007, 040, 062, 142, 137, 382, 703
Charter	11524, 10822, 10845, 11656, 12006, 10154, 11256, 10156, 11265, 10060, 10650, 11156, 11356, 11704, 0154, 0156, 0060, 1256, 0832, 1704, 1936, 0650, 1156, 1656, 1935, 0845, 1356, 1918, 1945, 015, 030, 007, 040, 062, 101, 142, 045, 137, 138, 325, 258, 031, 038, 039, 423, 571
Comcast	11656, 11156, 11256, 11704, 10845, 11356, 10060, 10650, 11265, 10154, 10765, 10767, 10178, 11314, 10700, 10702, 11935, 10832, 11959, 10036, 10149, 11343, 11369, 10781, 10003, 10250, 10156, 0060, 003, 0154, 0156
Cox	074, 168, 170, 822, 093, 991, 156, 060, 154, 093, 030, 031, 038, 039, 0170, 0074, 0168, 1270, 0060, 0154, 0156, 1256, 1265, 1945, 1704, 1656, 1635, 1356, 1343, 1325, 1306, 1156, 0845, 0832, 0650, 0149, 0036, 1369, 1042, 1060, 1061, 1062, 1087, 1091, 1097, 1098, 1130, 1131, 1183, 1524, 1935, 2006, 1959, 1936, 1164, 2724
DirecTV	10156, 11656, 11256, 11704, 11356, 10060, 10650, 10154, 10765, 10178, 10700, 10702
Dish Network	617, 631, 590, 618, 635, 680, 688, 750, 847, 800, 526, 851, 852, 595, 908, 757, 850, 802, 785, 743, 849, 622, 789, 771, 744, 243, 117
RCA	11524, 11656, 10156, 11156, 11256, 12006, 11265, 11704, 11945, 10845, 1356, 12724
Rogers	1524



Time Warner	0156, 0060, 0154, 1042, 1060, 1061, 1062, 1087, 1091, 1097, 1098, 1130, 1131, 1172, 1173, 1183, 1286, 1317, 1325, 1327, 1334, 1345, 1346, 1355, 1364, 1365, 0016, 0017, 0090, 0096, 0117, 0118, 0129, 0131, 0180, 0206, 2001, 0011, 0021, 0041, 0051, 0061, 0081, 0101, 0111, 0171, 0191, 0211, 0471, 0701, 0411, 0501, 1301, 1351, 1441, 1781, 1951, 2021, 0341, 2341, 2481, 0861, 2351, 3671, 2801, 3821, 4151, 3921, 3931, 1256, 1265, 1945, 1935, 1704, 1656, 1635, 1356, 1343, 1306, 1156, 0845, 0832, 0650, 0149, 0036, 1190, 1014, 1015, 1127, 1007, 1252, 1246, 1219, 1212, 1168, 1163, 1018, 1114, 1028, 1071, 1300, 1338, 1353, 1369, 030, 007, 040, 062, 101, 142, 137, 045, 015, 062, 142, 137, 703, 138, 230, 258, 325
--------------------	-------------------------------------------------------------------------------------------------------------------------------------------------------------------------------------------------------------------------------------------------------------------------------------------------------------------------------------------------------------------------------------------------------------------------------------------------------------------------------------------------------------------------------------------------------------------------------------------------------------------------------------------------------------------------------------------------------------------------------------

Verizon.	0087, 0181, 0183, 0677, 0859, 0872, 1172, 1183, 1283, 1292, 1383, 1683, 1731, 3015, 3022, 3023, 3051, 3052, 3053, 3055, 3059, 3062, 3066, 3072, 3074, 3078, 3080, 3087, 3089, 3093, 3147, 3167, 3168, 3169, 3171, 3173, 3182, 3187, 3188, 3207, 3214, 3220, 397
-----------------	-----------------------------------------------------------------------------------------------------------------------------------------------------------------------------------------------------------------------------------------------------------------

Tips

- The brand name is often visible on the front of the universal remote control, and the model number is often visible on the back.
- If your universal remote control isn't listed in the table, refer to your universal remote control's instructions and try codes for the brands Orion, Emerson, Memorex, Sansui, Sylvania, or Zenith. You may need to try several codes before finding a match.

Turning on your TV for the first time

The first time you turn on your TV, the Initial Setup wizard opens. The wizard guides you through setting up basic settings including the menu language, time zone, Store or Home mode, TV signal source, and the channel list.

Note

You must select a voice guide setting, a language, time zone, and Home or Store mode. You cannot exit the Initial Setup wizard until you make these selections.

1. Make sure that you have:

- Installed the remote control batteries. (See page 36.)
- Connected an antenna, cable TV, or satellite TV. (See page 19 through 23.)
- Connected the power cord. (See page 35.)

2. Press  (power) to turn on your TV. The Initial Setup wizard opens.

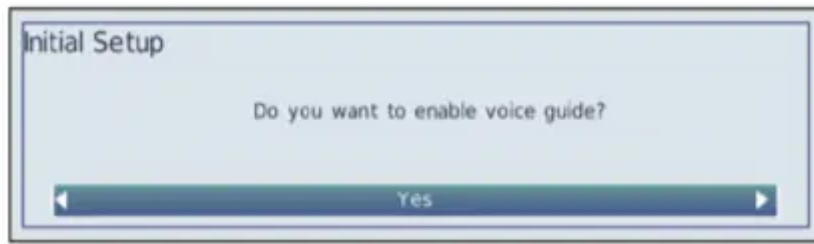

3. Press ◀ or ▶ to select Yes (to turn on the Voice Guide) or No (to turn off the Voice Guide), then press ENTER.



4. Press ◀ or ▶ to highlight a language. Press ▲ or ▼ to highlight Time Zone, press ◀ or ▶ to select your time zone, then press ENTER.

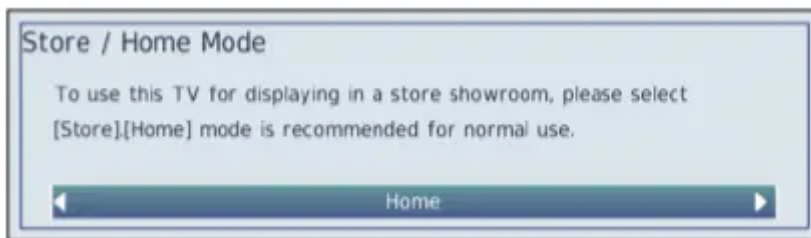

5. Press ◀ or ▶ to highlight Home or Store mode, then press ENTER.

For normal home use, you should select Home mode. If you select Store mode, every time you turn on your TV, it will be in Store mode. Store mode is not an energy savings mode.

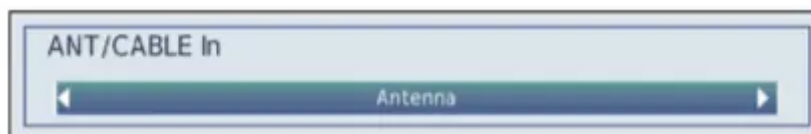

6. Press ◀ or ▶ to highlight Antenna or Cable, then press ENTER.

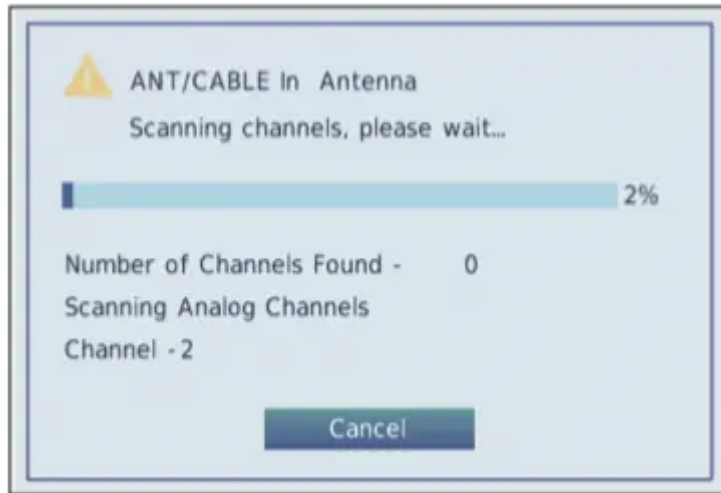

7. If you are using an antenna or connecting a cable box directly to a wall jack, press ENTER again. Your TV starts scanning for channels available in your viewing area.

OR

If you connected a cable box or a satellite box, press EXIT to close the wizard. You do not need to scan for channels.

After the wizard closes, the Auto Tuning (Antenna) menu opens with the first found channel highlighted.

8. Press EXIT to close the menu.

Setting up the ANT / CABLE IN jack

If you connect an antenna or cable TV without a box to the ANT / CABLE IN jack, you need to set up the jack so your TV correctly displays channels.

1. Press MENU, press ▲ or ▼ to highlight Installation, then press ENTER.

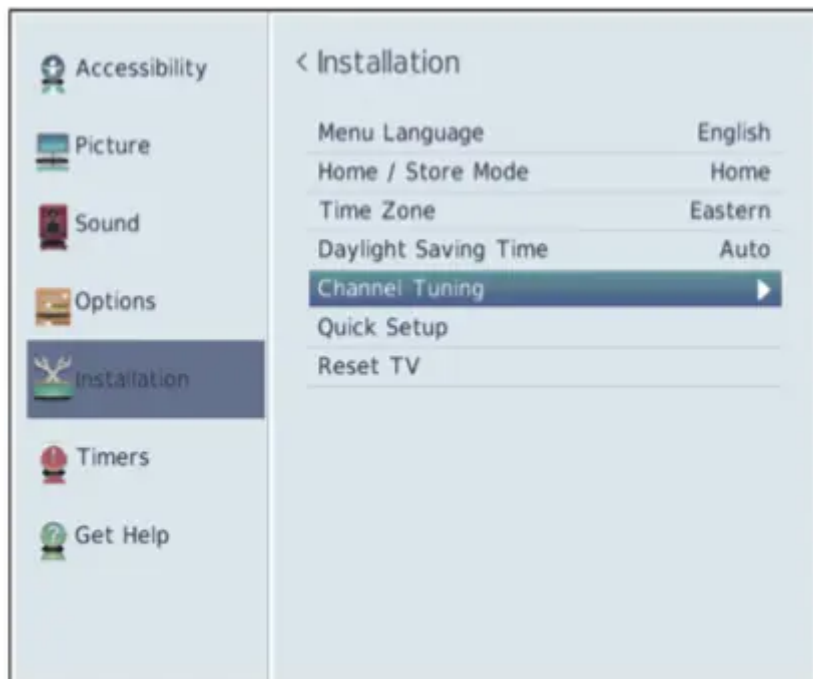

2. Highlight Channel Tuning, then press ENTER.

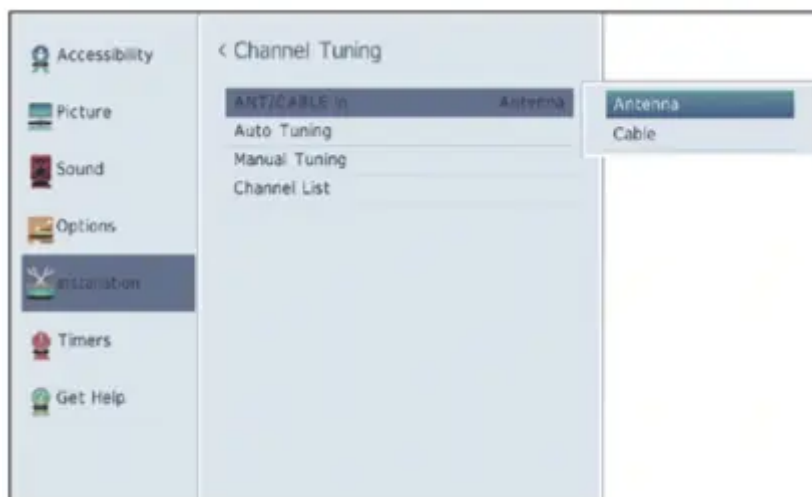

3. Highlight ANT/CABLE In, then press ENTER.

4. Highlight your TV input source, then press ENTER.



Select:

- Antenna if you connected an antenna to the ANT / CABLE IN jack
- Cable if you connected cable TV without a box to the ANT / CABLE IN jack

5. Press EXIT to close the menu.

Understanding the basics

Turning your TV on or off

1. Make sure that the power cord is connected securely and correctly. For more information, see Connecting power on page 35.
2. Press  (power) to turn on your TV. The power indicator turns off.
3. Press  (power) again to turn off your TV. Your TV enters standby mode, and the power indicator turns red.

Warning

When your TV is in standby mode, it is still receiving power. To completely disconnect power, unplug the power cord.

Note

If your TV does not receive an input signal for 15 minutes, it automatically goes into standby mode.

Last Mode Memory

If power is interrupted while you are viewing TV, the Last Mode Memory feature automatically turns on your TV when the power is restored.

Selecting the video input source

1. Press INPUT. The Input Selection list opens.

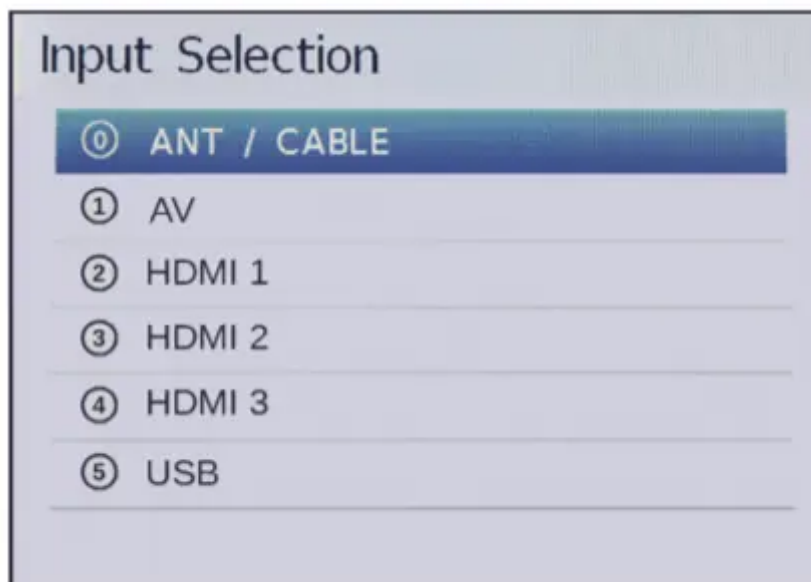

2. Do one of the following:
 - Press INPUT one or more times until the video input you want is selected.

- Press ▲ or ▼ to highlight the video input you want, then press ENTER.
- Press the number for the video input you want. You can select:
 - 0 for a device connected to the ANT / CABLE IN jack
 - 1 for an AV device connected to the VIDEO jack
 - 2 for a device connected to the HDMI IN 1 (ARC) jack
 - 3 for a device connected to the HDMI IN 2 jack
 - 4 for a device connected to the USB jack (32" model) or HDMI IN 3 jack (49" or 55" model)
 - 5 for a USB flash drive connected to the USB jack (49" or 55" model).

Note

The 32" model does not have the HDMI 3 option.

3. Press EXIT to close the menu.

Notes

- If a CEC-compatible device is connected to an HDMI jack, the HDMI® CEC icon appears in the list.
- If a connected CEC-compatible device has CEC-compatible devices connected to it, a separate device selection pop-up window appears. For example, the pop-up window for a CEC-compatible DVD player with a CEC-compatible audio receiver connected might appear as follows:

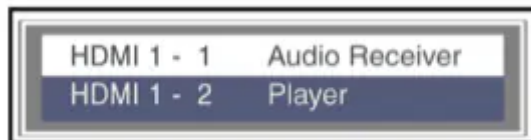

- If you press INPUT to select a CEC-compatible device from the pop-up window, the device may turn on.

On-screen menu overview

Notes

- Depending on the signal source selected, you may see different options on your screen.
- Menu items that are not selectable are grayed out.

Accessibility menu



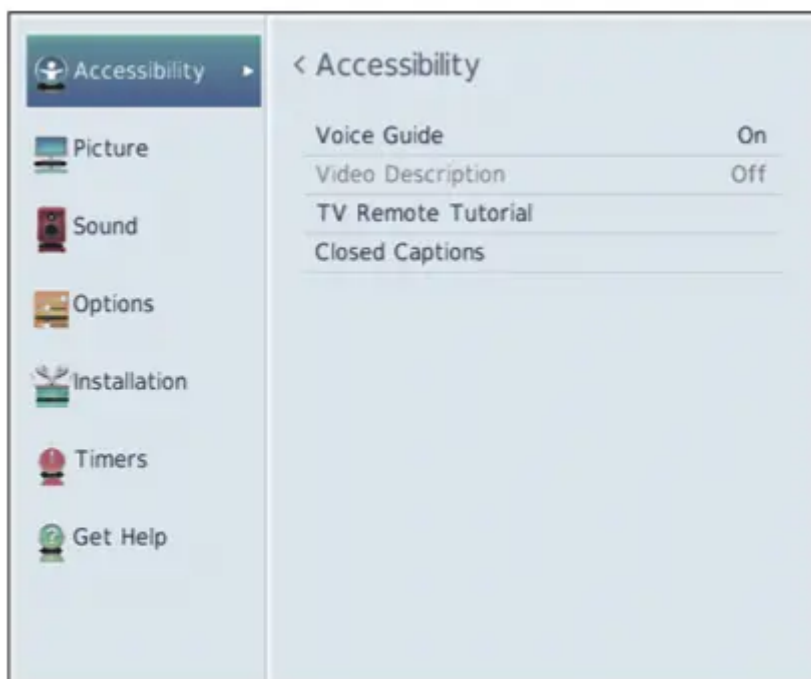

Picture menu

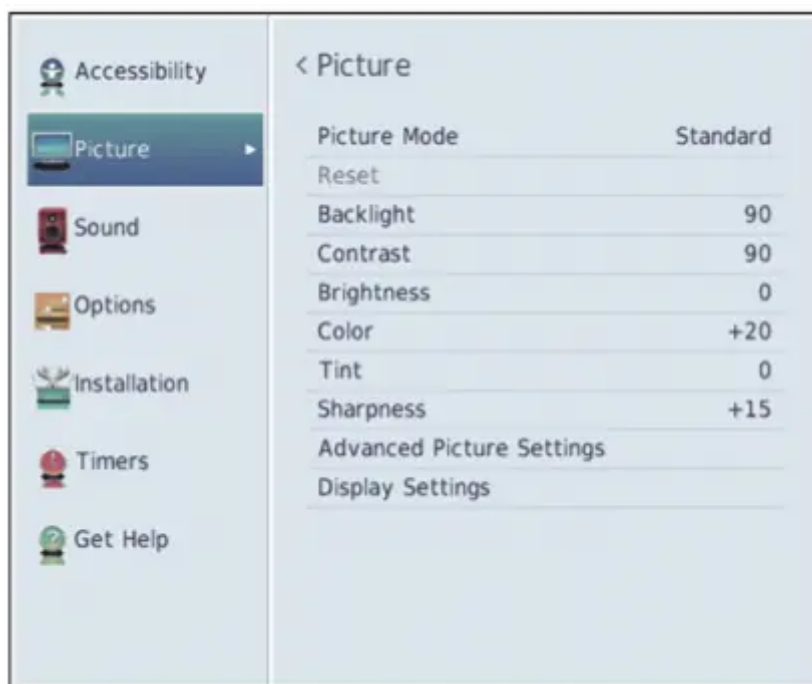

Sound menu



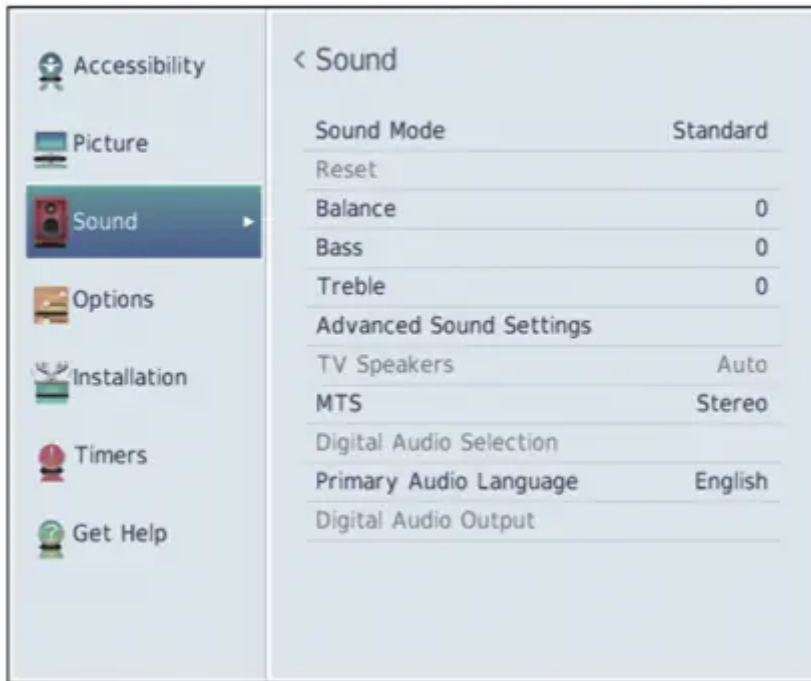

Options menu

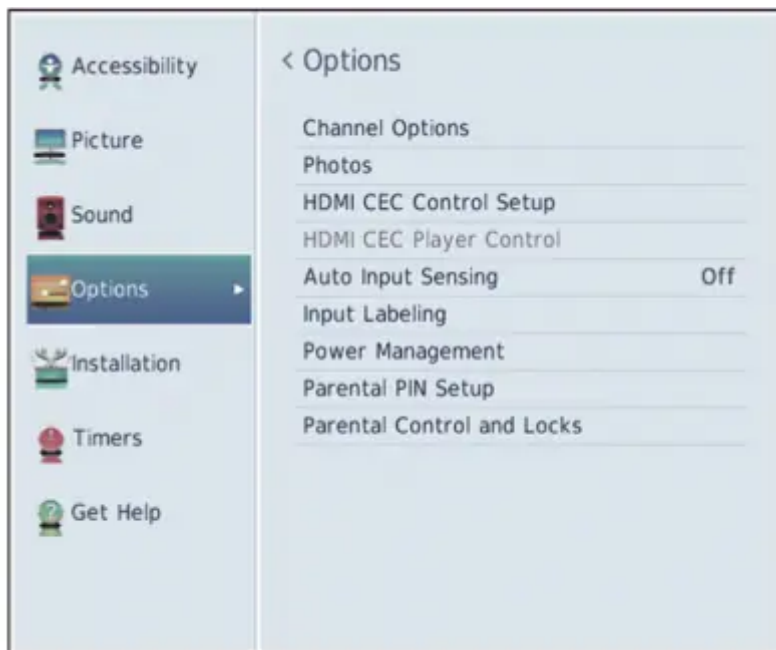

Installation menu



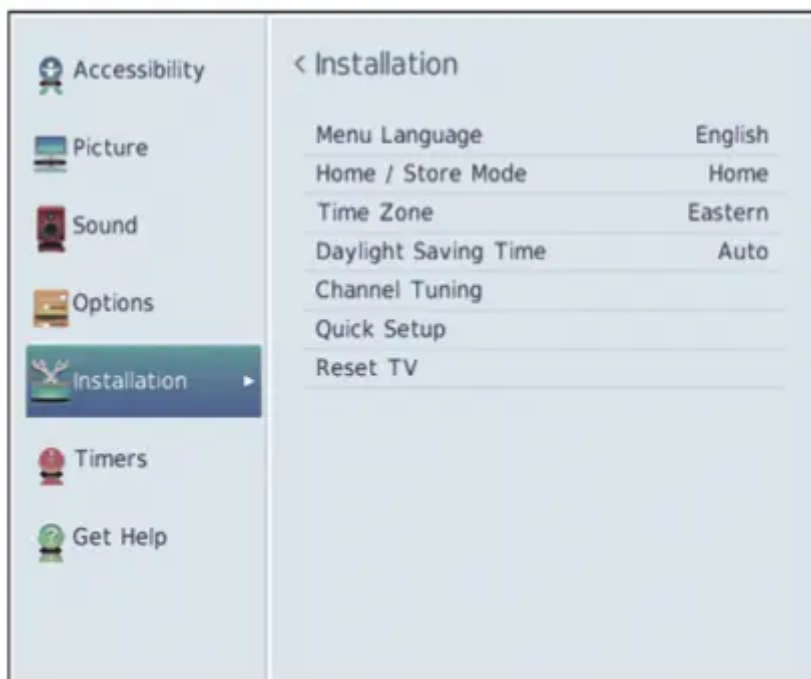

Timers menu

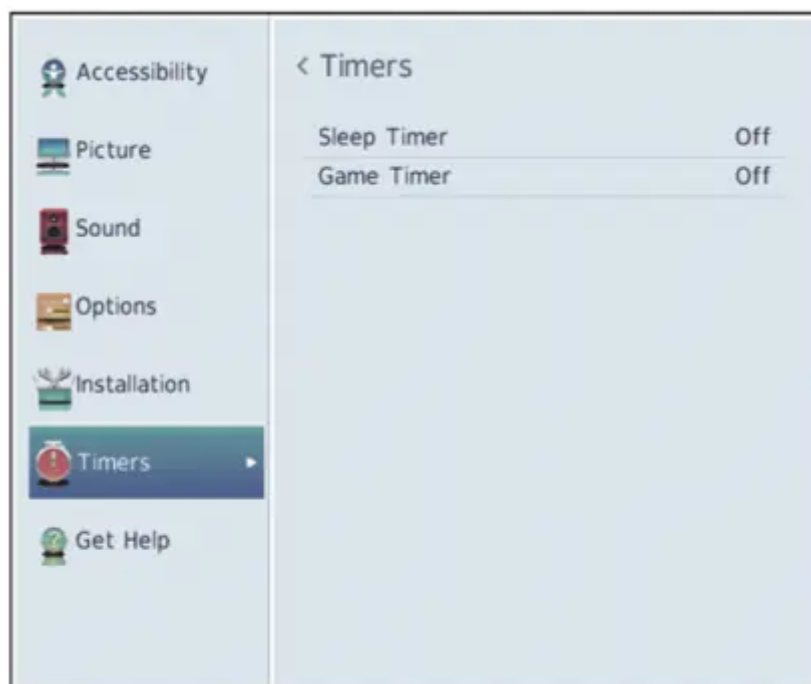

Get Help menu



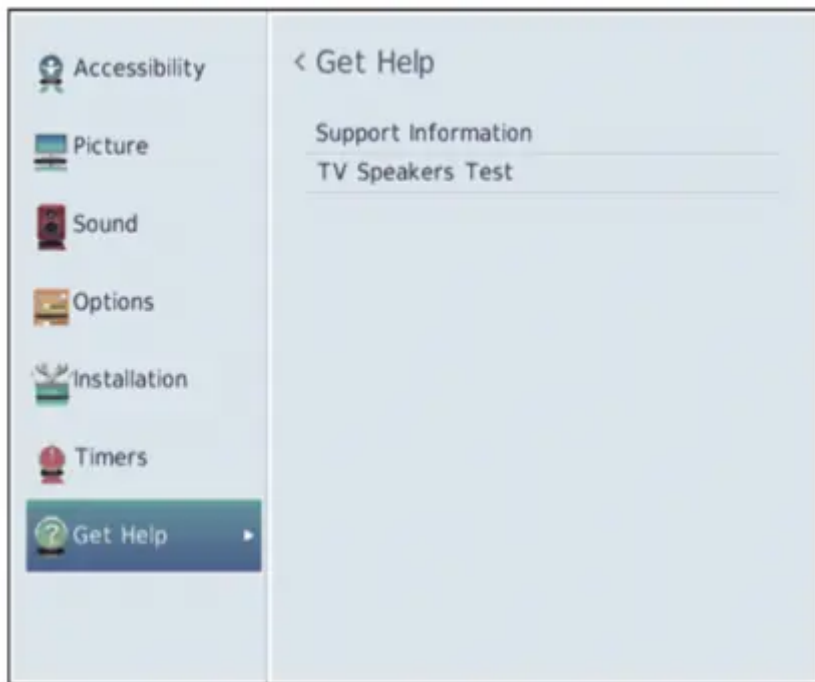

Navigating the menu

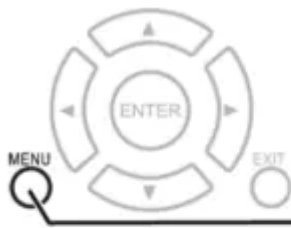

Press **MENU** to open the on-screen menu.

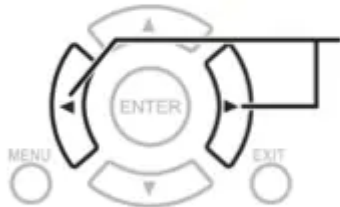

Press the right or left arrow to move the cursor on the screen or to adjust a selected item.

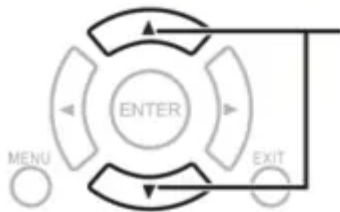

Press the up or down arrow to select menu options.

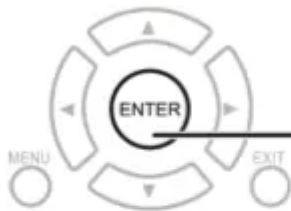

Press **ENTER** to confirm a selection or enter a sub-menu.

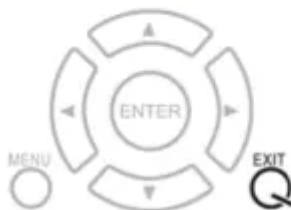

Press **EXIT** to close the menu.

Adjusting the volume

- Press VOL+ or VOL– to increase or decrease the volume.
- Press MUTE to mute the sound. Press MUTE again to turn the sound back on.

Note

If you adjust a setting on the Sound menu while the mute is active, the mute feature is cancelled.

Selecting a channel

- Press CH▲ or CH▼ to go to the next or previous channel on the memorized channel list.
- Press the number buttons to enter the channel number you want, then wait for the channel to change or press ENTER to immediately change the channel.
- To select a digital sub-channel, press the number buttons to select the main digital channel, press (sub-channel), then press the number button for the sub-channel. Wait for the channel to change, or press ENTER to immediately change the channel. For example, to tune to channel 5-1, press 5, (sub-channel), then 1.

Note

Button presses must be within two seconds of each other.

- Press CH RTN (return) to go to the last viewed channel or input.
- Press FAV to open the favorite channel list, press ◀ or ▶ to highlight a channel, then press ENTER. For information about setting up a favorite channel list, see Setting up the Favorites list on page 58.

Note

If a list has more than one page, press ◀ or ▶ to scroll through the pages.

Viewing channel information

Press INFO. The following status information is displayed:

- Current video input (for example ANT/CABLE or AV)
- If ANT/CABLE is the current video input, either CABLE (for cable TV) or ANT (for over-the-air broadcasts)
- If ANT/CABLE is the current video input, channel number
- Digital signal strength indicator
- If the input mode is HDMI®, Dolby® Digital, or PCM
- Video resolution
- Aspect ratio of incoming video signal (4:3 or 16:9)
- TV program or movie rating
- GameTimer (if set)

Pressing INFO also displays the following status information for digital channels:

- Title
- Duration

- Detailed program description

Note

If you pressed INFO, press INFO again to close the banner.

Maintaining

- Do not use your TV in areas that are too hot or too cold, because the cabinet may warp or the screen may malfunction. Your TV works best in temperatures that are comfortable to you.
- Storage temperatures are 32° to 122°F (0° to 50°C).
- Working temperatures are 41° to 104°F (5° to 40°C).
- Do not place your TV in direct sunlight or near a heat source.

Cleaning the TV cabinet

Clean the cabinet with a soft, lint-free cloth. If the cabinet is especially dirty, moisten a soft, lint-free cloth in a weak detergent solution, squeeze the excess moisture from the cloth, then wipe the cabinet with the cloth. Use a clean cloth to dry the cabinet.

Cleaning the TV screen

Clean the screen with a soft, lint-free cloth.

Troubleshooting

Use the following troubleshooting information to solve common problems.

Warning

Do not try to repair your TV yourself. Contact authorized service personnel.

Viewing support information

You may need to view system information during troubleshooting.

1. Press MENU, press ▲ or ▼ to highlight Get Help, then press ENTER.

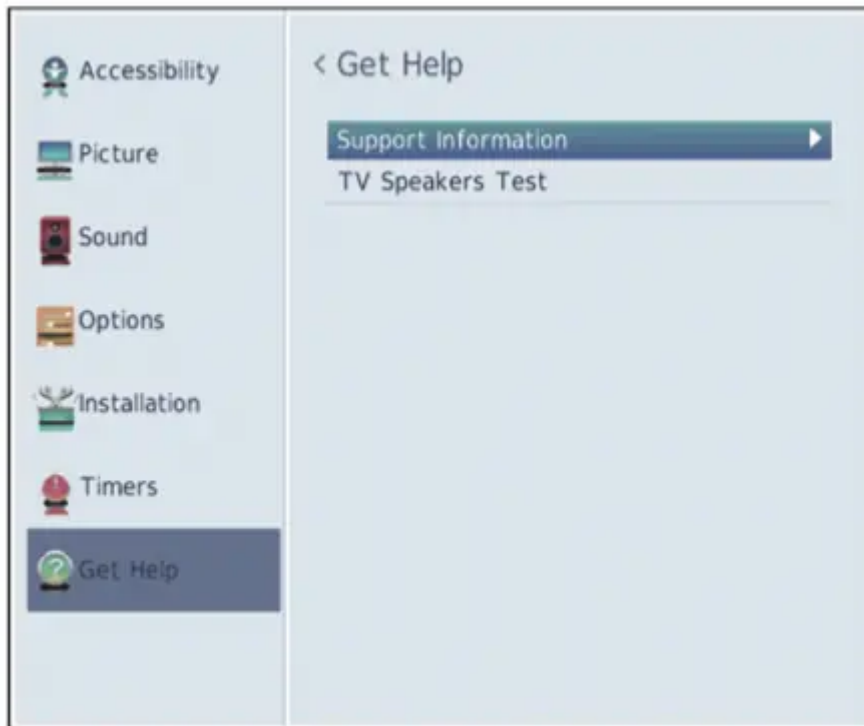

2. Highlight Support Information, then press ENTER. Your TV displays information about your system.

3. To close the screen and return to the Get Help menu, press ENTER.

OR To close the menu, press EXIT.

Testing the TV speakers

You can test your TV's speakers to make sure they are working correctly.

1. Press MENU, press ▲ or ▼ to highlight Get Help, then press ENTER.

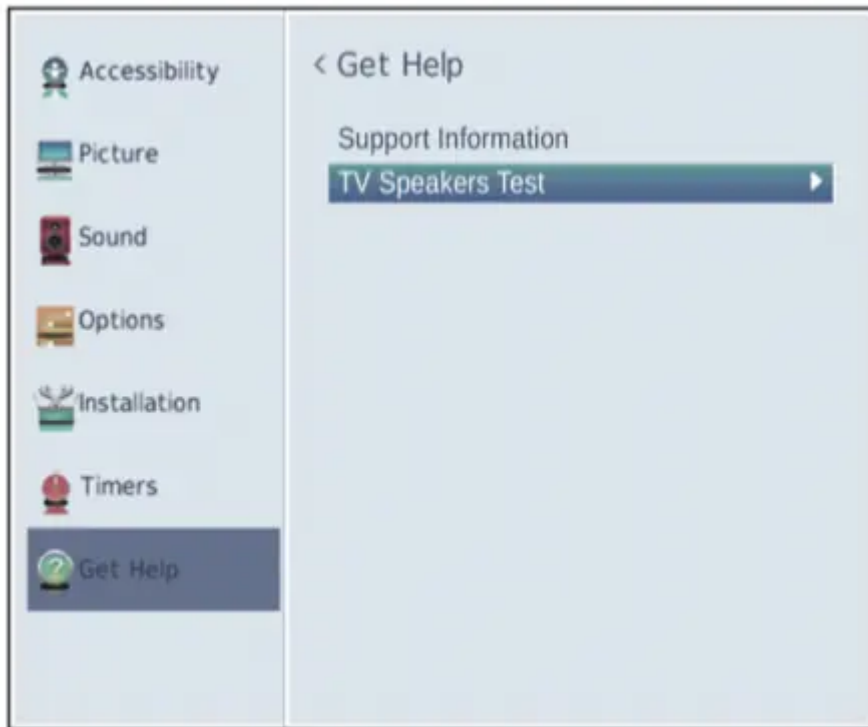

2. Highlight TV Speakers Test, then press ENTER.

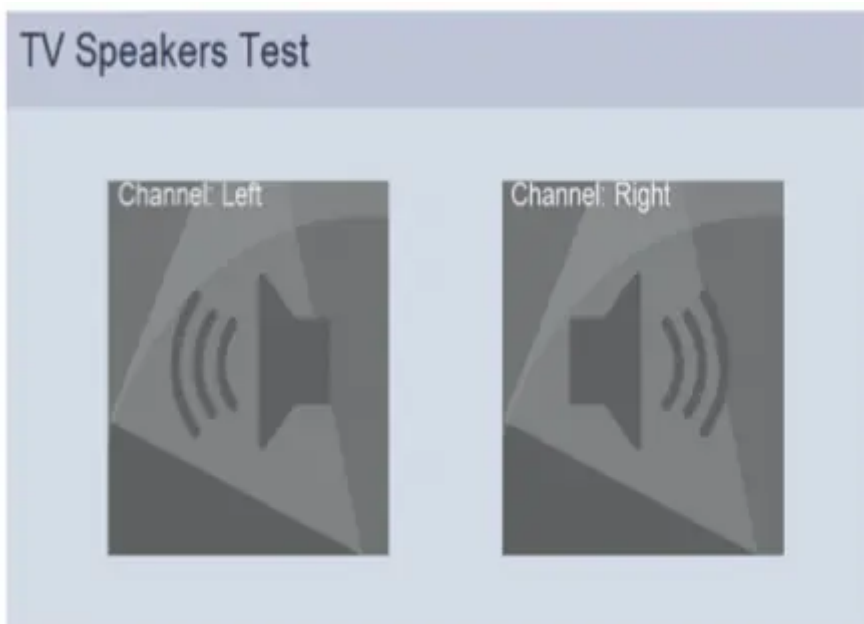

3. Your TV tests the left speaker, then the right speaker. You hear a voice, and as each speaker is tested, its icon is highlighted.

If one or both of the speakers fail the test, see Video and audio on page 70.

Restoring settings to the defaults

When you restore default settings, all the settings you have customized are reset.

1. Press MENU, press ▲ or ▼ to highlight Installation, then press ENTER.

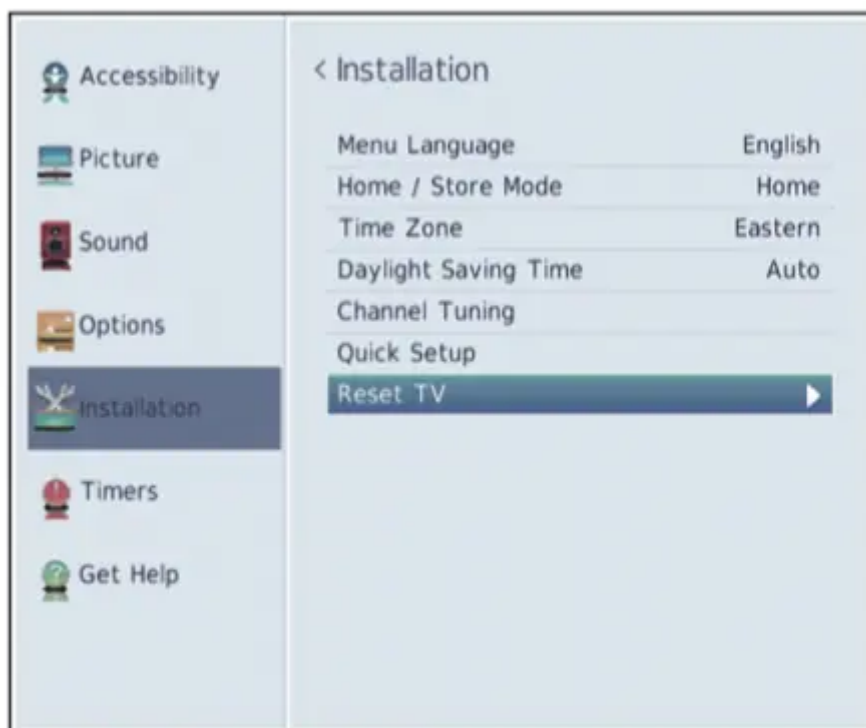

Note

If you have created a PIN, use the number buttons to enter it, then press ENTER.

2. Press ▲ or ▼ to highlight Reset TV, then press ENTER.

A confirmation screen opens.

3. Highlight Yes, (to reset) or No (to not reset), then press ENTER.

If you select Yes, your TV turns off, then turns on again. Complete the Initial Setup wizard and set up the ANT / CABLE IN jack. For more information, see Turning on your TV for the first time on page 38 and Setting up the ANT / CABLE IN jack on page 39.

OR

If you do not want to reset your TV to the factory defaults, highlight No, then press ENTER.

Turning off the automatic power-off feature

Your TV automatically turns off after 15 minutes when no video signal is detected.

You might want to change this setting to Off if:

- The incoming signal for an analog channel is too weak for your TV to detect.
- You connected an audio-only device (such as a CD player) to the AUDIO L and R jacks to listen to music through the TV speakers.

1. Press MENU, press ▲ or ▼ to highlight Options, then press ENTER.

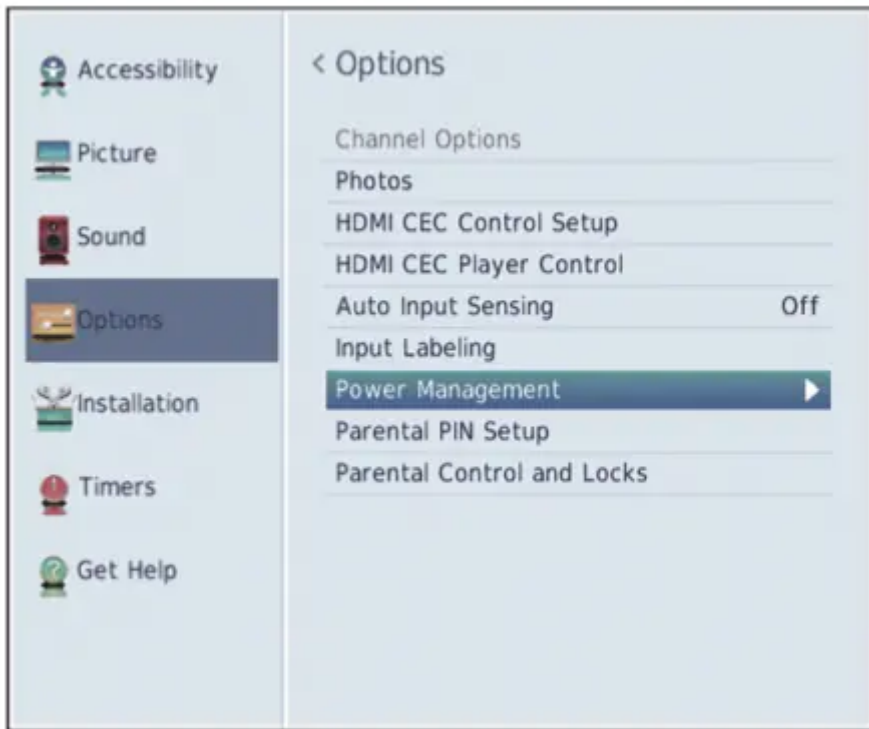

2. Highlight Power Management, then press ENTER.

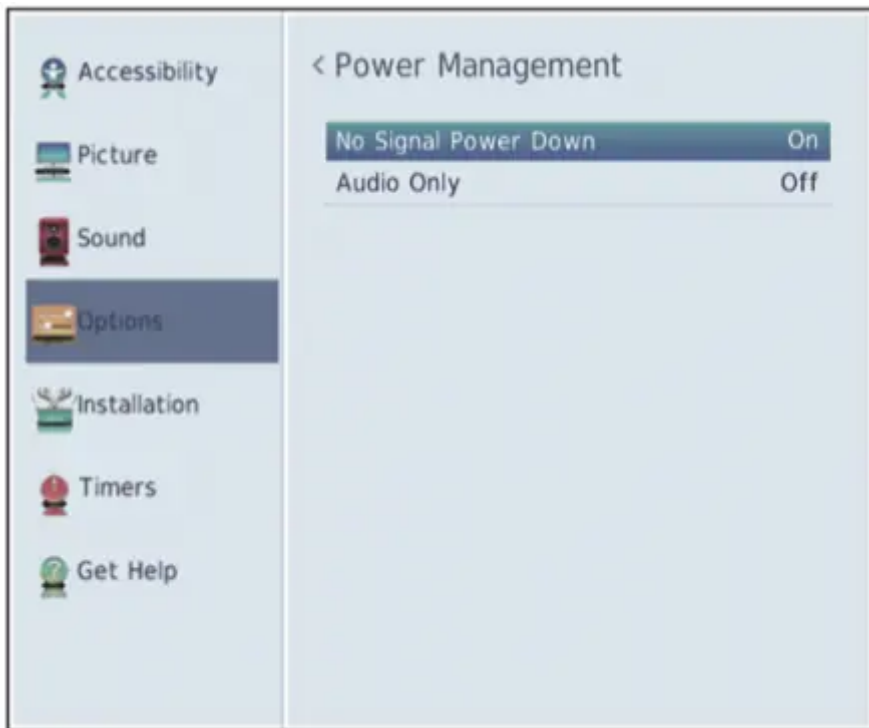

3. Highlight No Signal Power Down, then press ENTER.

4. Press ▲ or ▼ to select Off or On, then press ENTER.

5. Press EXIT to close the menu.

Video and audio

Problem	Solution
Picture does not fill the screen. There are black bars around the picture.	<ul style="list-style-type: none">• Press PIC SIZE to change the aspect ratio. See Adjusting the picture size on page 51.
No picture (screen is not lit) and no sound.	<ul style="list-style-type: none">• Press  (power) on the TV or the remote control.• Make sure that the Audio Only option is set to Off. See Playing TV audio only on page 55.• Make sure that the video cables are connected correctly and securely to your TV.• Adjust the contrast and brightness. See Adjusting the TV picture on page 49.• Make sure that the power cord is plugged into a working outlet.• Press INPUT and make sure that the correct video input source is selected. See Selecting the video input source on page 40.• Try another channel. The station may be experiencing problems.• Make sure that the incoming signal is compatible.• Make sure that the antenna or cable TV is connected correctly and securely. See Connecting a cable or satellite box on page 19 or Connecting an antenna or cable TV (no box) on page 23.• Check the closed caption settings. Some TEXT modes can block the screen. See Using closed captioning on page 63.

<p>Dark, poor, or no picture (screen is lit), but sound is good.</p>	<ul style="list-style-type: none"> • Try another channel. The station may be experiencing problems. • Make sure that the antenna or cable TV is connected correctly and securely. See Connecting a cable or satellite box on page 19 or Connecting an antenna or cable TV (no box) on page 23. • Adjust the brightness. See Adjusting the TV picture on page 49. • Press PIC SIZE to change the aspect ratio. See Adjusting the picture size on page 51. • If you are using an antenna and the signal strength is low, adjust the antenna or use a highly directional outdoor antenna or set-top antenna with a built-in amplifier. • Make sure that the video cables are connected correctly and securely to your TV. • The video cable(s) you are using may be bad. Try a new set. • Try another channel. The station may be experiencing problems.
<p>No color, dark picture, or color is not correct.</p>	<ul style="list-style-type: none"> • Try another channel. The station may be experiencing problems. • Adjust the color settings. See Adjusting the TV picture on page 49. • Make sure that the video cables are connected correctly and securely to your TV. • Make sure that the antenna or cable TV is connected correctly and securely. See Connecting a cable or satellite box on page 19 or Connecting an antenna or cable TV (no box) on page 23. • If you are using an antenna and the signal strength is low, adjust the antenna or use a highly directional outdoor antenna or set-top antenna with a built-in amplifier.

<p>Only snow (noise) appears on the screen.</p>	<ul style="list-style-type: none"> • Try another channel. The station may be experiencing problems. • Make sure that the antenna or cable TV is connected correctly and securely. See Connecting a cable or satellite box on page 19 or Connecting an antenna or cable TV (no box) on page 23. • If you are using an antenna and the signal strength is low, adjust the antenna or use a highly directional outdoor antenna or set-top antenna with a built-in amplifier.
<p>Picture quality is good on some channels and poor on others. Sound is good.</p>	<ul style="list-style-type: none"> • The problem may be caused by a poor or weak signal from the broadcaster or cable TV provider. • If you connect to cable without a set-top box and experience poor picture quality, you may need to install a set-top box to improve signal reception and picture quality. Contact your cable TV provider about upgrading to a set-top box.
<p>Dotted lines or stripes appear on the screen.</p>	<ul style="list-style-type: none"> • Make sure that the antenna or cable TV is connected correctly and securely. See Connecting a cable or satellite box on page 19 or Connecting an antenna or cable TV (no box) on page 23. • If you are using an antenna and the signal strength is low, adjust the antenna or use a highly directional outdoor antenna or set-top antenna with a built-in amplifier. • Make sure that the video cables are connected correctly and securely to your TV. • The video cable(s) you are using may be bad. Try a new set. • Other devices (for example, a surround sound receiver, external speakers, fans, or hair dryers) may be interfering with your TV. Try turning off one device at a time, then back on to determine which device is causing interference. After you have determined which device is causing interference, move it further from the TV to eliminate the interference.
<p>Double images.</p>	<ul style="list-style-type: none"> • Use a highly directional outdoor antenna, cable TV, or satellite TV.



<p>The picture has a few bright or dark spots.</p>	<ul style="list-style-type: none"> • A few bright or dark spots on an LCD screen is normal. It does not affect the operation of your TV.
<p>Video description or voice guide does not work.</p>	<ul style="list-style-type: none"> • Make sure that your TV is not muted and the volume is turned up. • Make sure that the options listed under the Accessibility menu are turned on. See Adjusting sound settings on page 54. • Video descriptions are not available on all broadcasts. • Some remote functions are not narrated.
<p>Good picture, but no sound.</p>	<ul style="list-style-type: none"> • Increase the volume. • Make sure that the sound is not muted. • Make sure that you do not have headphones connected. When headphones are connected, the TV speakers are muted. • Make sure that the TV Speakers option on the Sound menu is not set to Off. • If you are using a home theater system, soundbar, or external speaker system, make sure it is turned on and is not muted. • If you are using a home theater system, soundbar, or external speaker system, make sure that you have selected the correct output mode. • If you are using a home theater system, soundbar, or external speaker system and have connected it with a digital optical cable, go to the Sound menu, highlight Digital Audio Output, then press ENTER. Highlight Audio Format, then press ENTER. Press ← or → to select PCM, then press ENTER. See the Digital Audio Output option in Adjusting sound settings on page 54. • Make sure that the audio cables are connected correctly and securely to your TV. • Make sure that the antenna or cable TV is connected correctly and securely. See Connecting a cable or satellite box on page 19 or Connecting an antenna or cable TV (no box) on page 23. • The audio cables you are using may be bad. Try a new set.

<p>Poor picture.</p>	<ul style="list-style-type: none"> • Make sure that the room is not too bright. Light reflecting off the screen can make the picture difficult to see. • If an S-VHS camera or a camcorder is connected while another connected device is turned on, the picture may be poor. Turn off one or more devices.
<p>Good sound, but poor color.</p>	<ul style="list-style-type: none"> • Adjust the contrast, color, and brightness settings. See Adjusting the TV picture on page 49.
<p>Audio noise.</p>	<ul style="list-style-type: none"> • Other devices (for example, a surround sound receiver, external speakers, fans, or hair dryers) may be interfering with your TV. Try turning off one device at a time to determine which device is causing interference. After you have determined which device is causing interference, move it further from the TV to eliminate the interference.
<p>No output from one of the speakers.</p>	<ul style="list-style-type: none"> • Adjust the audio balance. See Adjusting sound settings on page 54. • Make sure that the audio cables are connected correctly and securely to your TV.
<p>After images appear.</p>	<ul style="list-style-type: none"> • Do not display a still image, such as a logo, game, or computer image, for an extended period of time. This can cause a permanent after-image to be burned into the screen. This type of damage is not covered by your warranty.

Remote control

Problem	Solution
Remote control does not work.	<ul style="list-style-type: none">• Make sure that the power cord is plugged into a working outlet.• Make sure that there are no obstructions between the remote control and the remote control sensor on the front of the TV.• Point the remote control directly at the remote control sensor on your TV. For the location of the remote control sensor, see Aiming the remote control on page 36.• The supplied batteries are wrapped tightly in clear plastic. Make sure that you have removed this plastic from the batteries.• Make sure that the batteries are installed correctly. See Installing remote control batteries on page 36.• Replace dead batteries with new batteries. See Installing remote control batteries on page 36.

General

Problem	Solution
No power.	<ul style="list-style-type: none">• Make sure that the power cord is plugged into a working outlet.• Unplug the power cord, wait 60 seconds, then plug the cord back in and turn on your TV.• Other devices (for example, a surround sound receiver, external speakers, fans, or hair dryers) may be interfering with your TV. Try turning off one device, at a time, then turning on your TV to determine which device is causing interference. After you have determined which device is causing interference, move it further from the TV to eliminate the interference.
“No video” error message is displayed.	<ul style="list-style-type: none">• Press INPUT and make sure that you have selected the correct input for the device or service you are trying to use.• If you are using a cable or satellite box, use the remote that came with that box to change channels.

<p>After Auto Channel Search, there are no channels.</p>	<ul style="list-style-type: none"> • Reception can vary by channel depending on the broadcast power level of a given station. Contact your cable or satellite TV provider. • Make sure that the antenna or cable/satellite TV is connected securely to your TV. • Try replacing the cable between the antenna/cable or cable/satellite box and your TV.
<p>When I press INPUT, I cannot select my device (it is grayed out).</p>	<ul style="list-style-type: none"> • Make sure that the video input source for the device is not hidden. See Labeling a video input source on page 67. • Make sure that the video input sources are not locked. See Locking video inputs on page 62.
<p>One or more channels do not display.</p>	<ul style="list-style-type: none"> • Make sure that the channels are not blocked. See Locking channels on page 62. • Make sure that the channels are not hidden. The channel may have been deleted from the channel list. You can tune to the channel by pressing the number buttons or you can add the channel back to the channel list. See Hiding channels on page 57. • If you are using a cable or satellite box, use the remote that came with that box to change channels. • Press INPUT and make sure that you have selected the correct input for the device or service you are trying to use.
<p>Password is lost.</p>	<ul style="list-style-type: none"> • If you forget your PIN, open the screen where you enter your PIN, then press INFO four times within five seconds. The PIN is cleared and you can enter a new PIN. See Setting a new PIN on page 58.
<p>Some settings cannot be accessed.</p>	<ul style="list-style-type: none"> • If a setting is grayed, the setting is not available in the current video input mode (for example TV mode). Change to a different video input source. See Selecting the video input source on page 40.
<p>TV cabinet creaks.</p>	<ul style="list-style-type: none"> • When the TV is in use, the temperature rises naturally and may cause the cabinet to expand or contract which can cause a creaking noise. This is not a malfunction.

<p>The /INPUT button does not work.</p>	<ul style="list-style-type: none"> • Unplug the power cord, wait a few seconds, then plug the cord back in and turn on your TV.
<p>TV keeps turning off.</p>	<ul style="list-style-type: none"> • Make sure that the sleep timer is not turned on. See Setting the sleep timer on page 66.
<p>A retail banner is displayed.</p>	<ul style="list-style-type: none"> • You selected Store Mode when you ran the Initial Setup wizard. Go to the Installation menu, highlight Store / Home Mode, press ◀ or ▶ to select Home, then press ENTER.

CEC-compatible devices

Problem	Solution
<p>My TV is not displaying the video from the connected CEC device.</p>	<ul style="list-style-type: none"> • Make sure that the HDMI cable is connected securely to your TV and the device. • Make sure that the device is connected to your TV with an HDMI cable. • Make sure that the device is a CEC device. See the documentation that came with the device for more information. • Press INPUT and make sure that the correct video input source is selected. See Selecting the video input source on page 40. • Make sure that the HDMI-CEC Control feature is turned on. See Turning HDMI-CEC Control on or off on page 44. • Try adjusting the TV picture. See Adjusting the TV picture on page 49.

My TV is not playing the audio from the connected CEC device.

- Make sure that the HDMI cable is connected securely to your TV and the device.
- Make sure that the device is connected to your TV with an HDMI cable.
- Make sure that the device is a CEC device. See the documentation that came with the device.
- Make sure that the TV volume is turned up and not muted.
- Try adjusting the TV sound. See Adjusting sound settings on page 54.
- Make sure that the TV speakers are turned on and not muted. See Adjusting sound settings on page 54.
- Make sure that the HDMI-CEC Control feature is turned on. See Turning HDMI-CEC Control on or off on page 44.
- If you have connected an HDMI CEC audio receiver, adjust the volume on the receiver. When your TV detects an audio receiver, the TV speakers may turn off and sound plays through receiver speakers only.
- If you are using a home theater system, soundbar, or external speaker system, make sure that it is turned on and is not muted.
- If you are using a home theater system, soundbar, or external speaker system, make sure that you have selected the correct output mode.
- If you are using a home theater system, soundbar, or external speaker system and have connected with a digital optical cable, go to the Sound menu, highlight Digital Audio Output, then press ENTER. Highlight Audio Format, then press ENTER. Press ▲ or ▼ to select PCM, then press ENTER. See the Digital Audio Output option in Adjusting sound settings on page 54.

<p>My TV's remote control does not control the device.</p>	<ul style="list-style-type: none"> • Make sure that there are no obstructions between the remote control and the remote control sensors on your TV and the device. • Depending on the device, all the buttons may not work. • Make sure that the HDMI-CEC Control feature is turned on. See Turning HDMI-CEC Control on or off on page 44. • If you are trying to control the volume on an HDMI CEC audio receiver using your TV remote control, make sure that the Amplifier Control option is set to On. See Turning Amplifier Control on or off on page 46. • The device may not support this feature. See the documentation that came with the device for more information.
<p>The device does not show up in the list of CEC devices.</p>	<ul style="list-style-type: none"> • Make sure that the device is turned on. • Make sure that the HDMI cable is connected securely to your TV and the device. • Make sure that the device is connected to your TV with an HDMI cable. • Make sure that the HDMI-CEC Control feature is turned on. See Turning HDMI-CEC Control on or off on page 44. • Make sure that the device is a CEC device. See the documentation that came with the device.



<p>My device does not turn off when I turn off my TV.</p>	<ul style="list-style-type: none"> • Make sure that the HDMI-CEC Control feature is turned on. See Turning HDMI-CEC Control on or off on page 44. • Make sure that Auto Standby is set to On. See Turning Auto Standby on or off on page 45. • The device may not support this feature. See the documentation that came with the device for more information.
<p>My TV does not turn on when I turn on my device.</p>	<ul style="list-style-type: none"> • Make sure that the HDMI-CEC Control feature is turned on. See Turning HDMI-CEC Control on or off on page 44. • Make sure that TV Auto Power is set to On. See Turning TV Auto Power on or off on page 45. • The device may not support this feature. See the documentation that came with the device for more information.
<p>I cannot select the Root Menu option.</p> <p>OR The device's root menu does not open when I select Root Menu.</p>	<ul style="list-style-type: none"> • The device may not support this feature. See the documentation that came with the device for more information.

Note

If the problem is not solved by using these troubleshooting instructions, turn off your TV, then turn it on again.

Warning

This content is compiled from multiple sources and is provided for reference purposes only. It may not be complete or fully applicable to all situations. If you are unable to resolve your issue, please contact the product manufacturer or an authorized service provider for official support.

