

Important safeguards

When using electrical appliances, basic safety precautions should always be followed to reduce the risk of fire, electric shock, and/or injury to persons, including the following:

1. Read all instructions.
2. This appliance is not intended for use by persons (including children) with reduced physical, sensory, or mental capabilities, or lack of experience and knowledge, unless they are closely supervised and instructed concerning use of the appliance by a person responsible for their safety.
3. Close supervision is necessary when any appliance is used by or near children. Children should be supervised to ensure that they do not play with the appliance.
4. Do not touch hot surfaces. Use handles or knobs. Use pot holders when removing hot containers.
5. To protect against risk of electrical shock, do not immerse cord, plug, or base in water or other liquid.
6. Unplug from outlet when not in use and before cleaning. Allow to cool before putting on or taking off parts.
7. The use of accessory attachments not recommended by the appliance manufacturer may cause injuries.
8. Do not operate any appliance with a damaged supply cord or plug, or after the appliance malfunctions or has been dropped or damaged in any manner. Supply cord replacement and repairs must be conducted by the manufacturer, its service agent, or similarly qualified persons in order to avoid a hazard. Call the provided customer service number for information on examination, repair, or adjustment.
9. Do not use outdoors.
10. Do not let cord hang over edge of table or counter or touch hot surfaces, including stove.
11. Do not place on or near a hot gas or an electric burner, or in a heated oven.
12. Extreme caution must be used when moving an appliance containing hot oil or other hot liquids.
13. To disconnect slow cooker, turn controls to Cancel () and then remove plug from wall outlet. To unplug, grasp the plug and pull from the outlet. Never pull from the power cord.
14. Do not use appliance for other than intended use.

15. Lift and open cover carefully to avoid scalding, and allow water to drip into the cooker.
16. CAUTION! Risk of electric shock. Do not cook in base. Cook only in removable vessel.
17. Do not place the unit directly under cabinets when operating as this product produces large amounts of steam. Avoid reaching over the product when operating.
18. WARNING! Spilled food can cause serious burns. Keep appliance and cord away from children. Never drape cord over edge of counter, never use outlet below counter, and never use with an extension cord.
19. Intended for countertop use only.
20. Vessel may remain hot after unit is turned off.

Parts and features

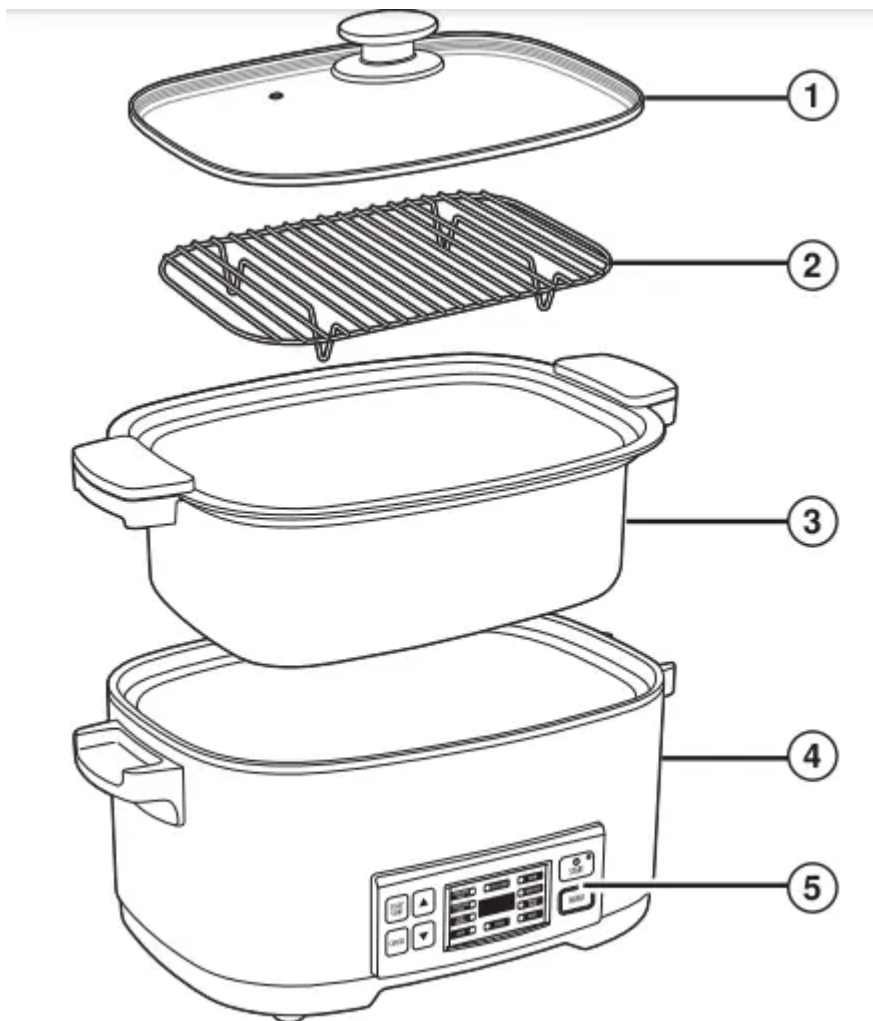

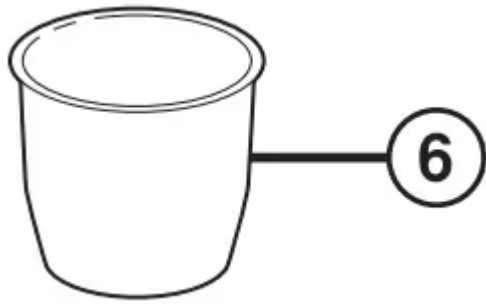

1. Lid
2. Steamer/Roasting Rack
3. Vessel
4. Base
5. Control Panel
6. Rice Measuring Cup

How to use the Multi-Cooker

BEFORE FIRST USE: Wash Vessel, Steamer/Roasting Rack, Rice Measuring Cup, and Lid in hot, soapy water. Rinse and dry.

Program functions

WHITE RICE and WHOLE GRAIN program cycles have default times that cannot be changed. The Multi-Cooker will adjust the cooking time throughout the cycle based on the amount of rice and moisture. The cooker may place a hold on the time or significantly decrease the cooking time as the moisture content changes. The Multi-Cooker automatically switches to WARM when done and will hold that temperature for up to 12 hours.

The rice measuring cup is an important tool in successful rice cooking and its size is standard in the rice industry. One Rice Measuring Cup equals 6 oz. (177 ml) or approximately 3/4 cup U.S. standard. Add desired amount of uncooked rice to Vessel; then fill with water to corresponding water line. Example: If you add 4 level Rice Measuring Cups of rice to the Vessel, add water to the “4” line of the Vessel. DO NOT exceed RICE MAX line.

Test Kitchen Tip: To prevent rice from foaming and spattering, stir 1 tablespoon vegetable oil into rice before adding water

FUNCTION	DEFAULT COOKING TIME
WHITE RICE	45 minutes
WHOLE GRAIN	60 minutes

Time functions

Six functions can be adjusted to the time you desire. After selecting function, press and hold the function button to start time. The display will show “ON” until the cooking temperature is reached, then the timer will count down. The Multi-Cooker automatically switches to WARM when done cooking and will keep warm up to 12 hours.



FUNCTION	TIME RANGE
ROAST	0–3 hours roasting time; preheat until Multi-Cooker beeps and set temperature is reached. Timer countdown begins when cooking temperature reaches 375°F (190°C). For best results, brown meats and poultry before roasting.
SAUTÉ	0–60 minutes; timer countdown begins when cooking temperature reaches 338°F (170°C). Always preheat and add food after the timer beeps.
SEAR/ BROWN	0–30 minutes; timer countdown begins when cooking temperature reaches 400°F (205°C). Always preheat and add food after the timer beeps.
STEAM	0–60 minutes; timer countdown begins when water boils. Add Steamer/ Roasting Rack and 2 cups (473 ml) liquid to Vessel before steaming.
SLOW COOK LOW	1–14 hours; timer countdown starts immediately. Automatically switches to WARM for a total cooking and warm time of 24 hours. For example, if slow cook time is 6 hours, WARM time is 18 hours (24 hours minus 6 hours).
SLOW COOK HIGH	Same as SLOW COOK LOW.

If using Multi-Cooker to cook rice, cereal, or grain:

1. Place Vessel straight down on Base. Make sure Vessel is securely placed into Base.

2. Plug into outlet. Press START  to turn on Multi-Cooker.

3. All function buttons will flash for 15 seconds. Press MENU button to select function.

Then press  or  to select time. Selected function and time will flash. Press START  button.

4. At the end of the cooking time, the Multi-Cooker will automatically switch to WARM. Multi-Cooker will keep warm up to 12 hours, then sound an alarm and switch to standby mode.

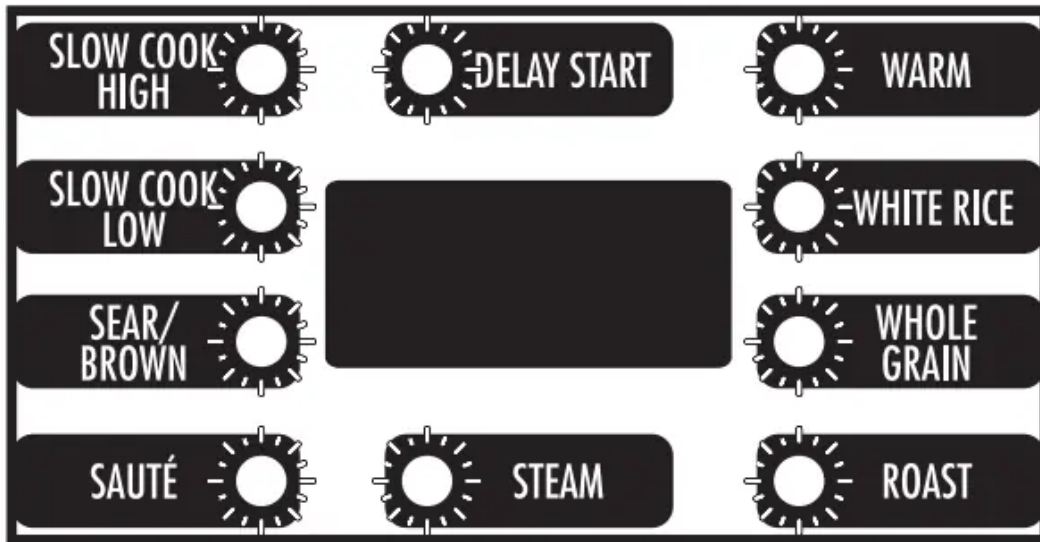



WARM

The WARM function should be used for already-cooked food. Do not cook on WARM. Timer will count up to display the total amount of time on WARM up to 12 hours.

DELAY START

The DELAY START function can be used with WHITE RICE, WHOLE GRAIN, and STEAM. Place water and food items in Vessel. Press MENU button to select function,

then press DELAY START button, and press  or  to adjust delay time. The function and DELAY START buttons will flash, and display will flash "0." Continue to press DELAY START to set delay time from 1 to 15 hours. MultiCooker will automatically start after 5 seconds, counting down the delay time. Cooking/steaming will begin once the unit has completed the delay time countdown. After cooking is complete, the MultiCooker will switch to WARM (except for STEAM).

Memory save

If the power is cut off and restarts within 5 minutes, the Multi-Cooker will remember the initial cooking status and continue the previous function automatically

Care and cleaning

1. Unplug Multi-Cooker and allow to cool.
2. Vessel and Steamer/Roasting Rack are dishwasher-safe. DO NOT use the “SANI” setting when washing in the dishwasher. “SANI” cycle temperatures could damage your product.
3. Wipe Base with a soft, damp cloth or sponge. To remove stubborn spots, use a mild, nonabrasive cleanser

Warning

This content is compiled from multiple sources and is provided for reference purposes only. It may not be complete or fully applicable to all situations. If you are unable to resolve your issue, please contact the product manufacturer or an authorized service provider for official support.