

Installation

Refrigerator at a glance

The actual refrigerator and provided component parts of your refrigerator may differ from the illustrations in this manual, depending on the model and the country.

Type A

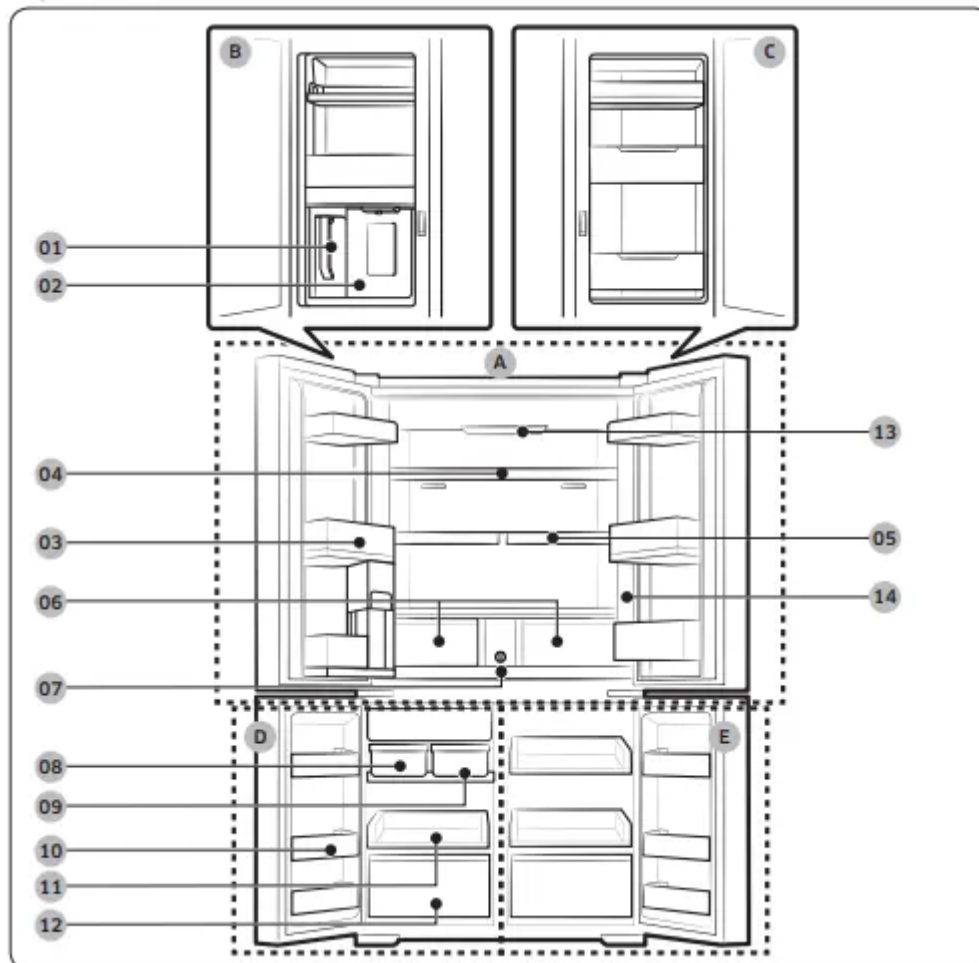

Type B

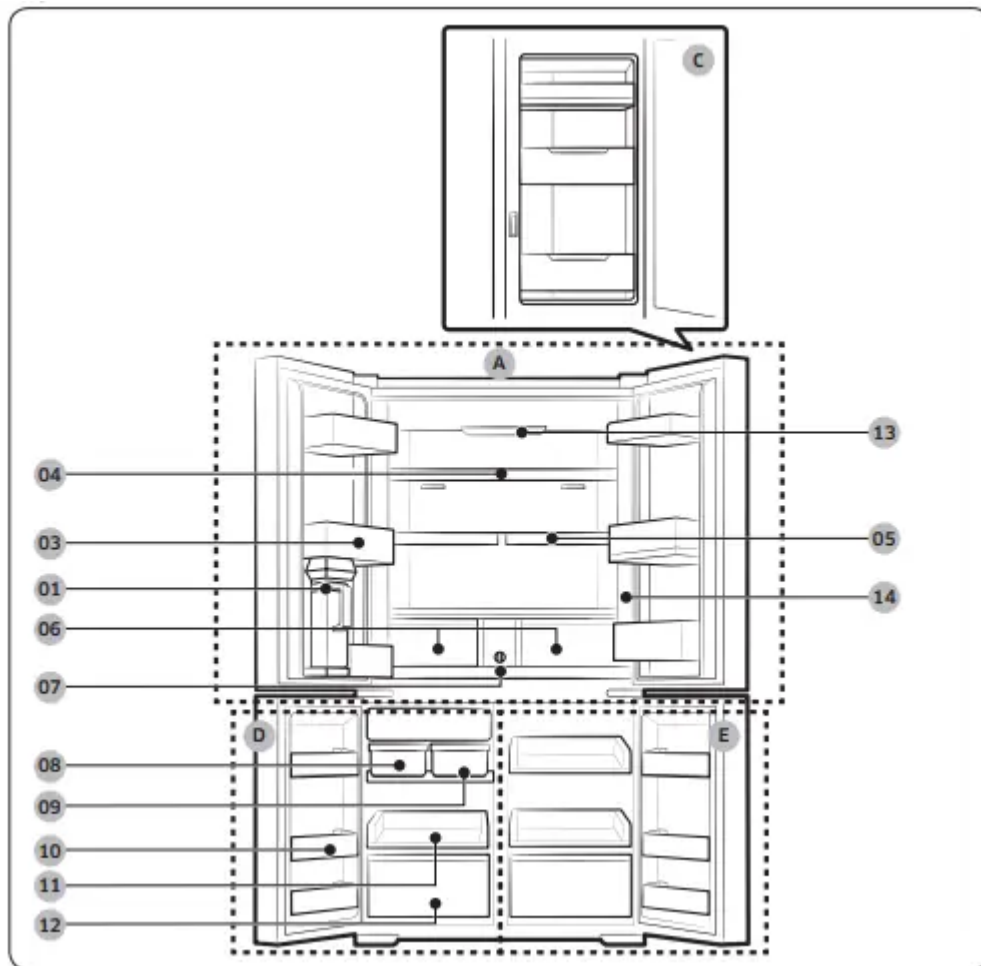

- 01 AutoFill Pitcher *
- 02 Water dispenser **
- 03 Fridge door bin
- 04 Fridge shelf
- 05 Quick Space shelf *
- 06 Crisper+ / Flex Crisper *
- 07 Water filter
- 08 Auto ice maker - Cubed Ice *
- 09 Auto ice maker - Ice Bites *
- 10 Freezer door bin
- 11 Freezer shelf
- 12 Freezer drawer
- 13 UV Deodorizing Filter *
- 14 Control panel

- A. Fridge
- B. Beverage Center **
- C. Showcase door *
- D. Freezer
- E. FlexZone

* Applicable models only

** Dispenser models only

Operations

Control panel

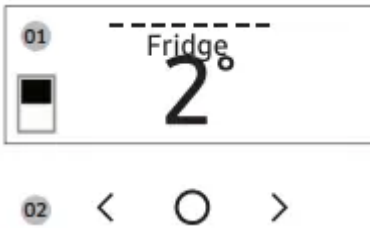

01 Display	Displays the menu, settings, and other information.
02 Buttons	<ul style="list-style-type: none">• When the display is off, tap any button to wake up the display.• Tap < or > to navigate left and right.• Tap ○ to confirm your selection.• Tap and hold ○ to enter the AP mode. (For more information, see the “SmartThings > Getting started” section on page 46.)

NOTE

- The control panel is designed to stay off when the refrigerator is not in use. It only becomes active and lights up when you open the door or tap the buttons.
- If the door is left open for 5 minutes, the internal light will blink for 5 minutes and turn off. It is to alert deaf and hard of hearing users that a door is open. Note that this function is normal.
- When you change the temperature on the panel, the panel displays the actual temperature inside the refrigerator until the temperature matches the temperature you set. Then, the panel displays the new set temperature. Note that it will take time for the refrigerator to reach the new temperature. It is normal. During this time, you need not set the temperature again.

Using the control panel

1. Tap any button (<, ○, or >) to wake up the display.
 2. Tap < or > to select the desired menu, and then tap ○ to confirm.
 3. Tap < or > to select the desired setting, and then tap ○ to confirm.
- For more information on available settings, see the Menu descriptions section.

Menu descriptions

Fridge	<ul style="list-style-type: none"> • You can set the fridge temperature from 34 ~ 44 °F (1~7 °C) or set the Power Cool function. • Power Cool speeds up the cooling process at maximum fan speed. The fridge keeps running at full speed for two and a half hours and then returns to the previous temperature.
Freezer	<ul style="list-style-type: none"> • You can set the freezer temperature from -8 ~ 5 °F (-23 ~ -15 °C) or set the Power Freeze function. • Power Freeze speeds up the freezing process at maximum fan speed. The freezer keeps running at full speed for 50 hours and then returns to the previous temperature. To freeze large amounts of food, activate Power Freeze for at least 20 hours before putting food in the freezer.
FlexZone	<ul style="list-style-type: none"> • You can set the FlexZone mode from one of the following modes. <ul style="list-style-type: none"> - Freeze: The temperature sets to the same temperature as the freezer. - Soft Freeze: The temperature sets to 23 °F (-5 °C). - Meat/Fish: The temperature sets to 30 °F (-1 °C). - Fruit/Veggies: The temperature sets to 36 °F (2 °C). - Beverage: The temperature sets to 39 °F (4 °C). <p>CAUTION</p> <ul style="list-style-type: none"> • Select the FlexZone mode accordingly to the type of food you store in there. • Do not store meat or food in the FlexZone with the Fruit/Veggies or Wine mode. Meat or food may spoil. • Do not store glass bottles in the FlexZone in Freeze or Soft Freeze mode. They may break and cause physical injury.
Flex Crisper	<ul style="list-style-type: none"> • You can set the Flex Crisper mode from one of the following modes. <ul style="list-style-type: none"> - Fridge: The temperature sets to the same temperature as the fridge. - Meat/Fish: Select this mode to store meat and fish fresh. (We recommend setting the fridge temperature below 37 °F (3 °C) to store meat and fish fresher in the Flex Crisper)



	<p>NOTE Most meat and fish can be stored in the Flex Crisper for 3 to 5 days (with some exceptions for certain types). Store them in the freezer if you want to keep it longer than 5 days.</p>
AutoFill Pitcher *	<ul style="list-style-type: none"> You can set the AutoFill Pitcher mode from one of the following modes. <ul style="list-style-type: none"> - On: Set to fill your water pitcher automatically. - Off: Set to turn off the function. <p>NOTE You can put tea or fruit into the infuser to make infused tea or water. If you want to keep the infused water in its initial concentration, turn the AutoFill Pitcher function off. (For more information, see the Water pitcher (AutoFill Pitcher) (applicable models only) section on page 52.)</p>
Cubed Ice*	You can start or stop making cubed ice.
Ice Bites *	You can start or stop making ice bites.
More Options	<p>You can change the settings for the following functions. Tap or to select the menu, and then tap  to confirm.</p> <p>UV Deodorizing Filter *: You can turn the UV Deodorizing Filter on or off.</p> <p>Peak Demand: You can turn the Peak Demand function on or off. (For more information on Peak Demand function, see the SMART GRID Function (Demand Response) section on page 48.)</p> <p>Filter Reset *: When you get the filter replacement message on the display, select this menu, and replace the filter according to onscreen instructions.</p> <p>Temp. Unit: You can set the temperature scale to Celsius or Fahrenheit.</p> <p>Door Alarm: You can turn on or off the Door Alarm.</p> <p>Wi-Fi Connect: You can turn on or off the Wi-Fi Connect. Turn it on to control and monitor your refrigerator on the SmartThings app. (For more information on SmartThings, see the SmartThings section on page 45.)</p> <p>* applicable models only</p>

NOTE Using Power Cool or Power Freeze increases power consumption.

Samsung account



You are required to register your Samsung account to use the app. If you don't have a Samsung account, follow the app's onscreen instructions to create a free Samsung account.

Getting started

Turn on the device you want to connect, open the SmartThings app on your phone, and then follow the instructions below.

If a pop-up appears saying that a new device has been found, tap **ADD NOW**.

If a pop-up doesn't appear, tap the **+** button, and then select the device you want to connect from the list of available devices.

If your device isn't in the list of available devices, tap **Supported Devices**, select the device type (Refrigerator), and then select the specific device model.

Follow the instructions in the app to set up your device. Once setup is complete, your refrigerator will appear as a "card" on your **Devices** screen.

Refrigerator app

Integrated control

You can monitor and control your refrigerator at home and on the go.

- Tap the refrigerator icon on the SmartThings Dashboard or tap the **Devices** icon at the bottom of the Dashboard, and then tap the refrigerator "card" to open the Refrigerator page.
- Check the operation status or notifications related to your refrigerator, and then change options or settings if necessary.

NOTE Some options or settings of the refrigerator may not be available for remote control.

Category	Item	Description
Monitoring	Fridge temperature	Displays the desired temperature setting of the fridge.
	Freezer temperature	Displays the desired temperature setting of the freezer.
	FlexZone settings	Displays the settings of the FlexZone.
	Diagnosis	Detects abnormal operations of the refrigerator.
	Energy monitoring	Checks the accumulated power consumption of the refrigerator for the last 180 days.
Functions	Ice making	You can turn the ice making function on or off, and check the current settings of the function.
		You can also check the status and progress of ice making.
	Power Cool	You can turn Power Cool on or off, and check the current settings.
	Power Freeze	You can turn Power Freeze on or off, and check the current settings.
	Fridge temperature	You can set the desired temperature of the fridge.
	Freezer temperature	You can set the desired temperature of the freezer.
	FlexZone settings	You can set the desired FlexZone mode.
	Sabbath Mode	You can activate and deactivate the Sabbath mode.
Alarms	Abnormally high temperature	This alarm is triggered when the fridge, the freezer, or the FlexZone has abnormally high temperatures.
	Door opening	This alarm is triggered if the fridge door, the freezer drawer, or the FlexZone drawer is open for a specific time.

AutoFill Pitcher overflowing	If the AutoFill Pitcher function senses an overflow, it triggers this alarm to let you know the status of the overflow.
Water filter replacement	This alarm reminds you that the water filter must be replaced.

Special features

Water pitcher (AutoFill Pitcher) (applicable models only)

Cold, purified water is always ready in the AutoFill Pitcher. You can put tea or fruits in the infuser to enjoy the various infused water you like.

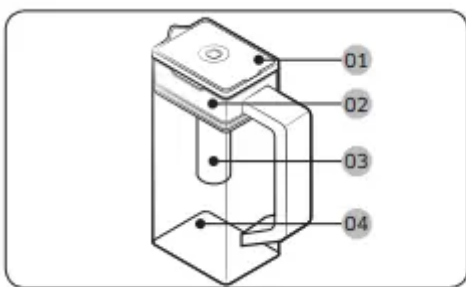

- 01 Lid
- 02 Infuser holder
- 03 Infuser
- 04 Body

To fill the Water pitcher

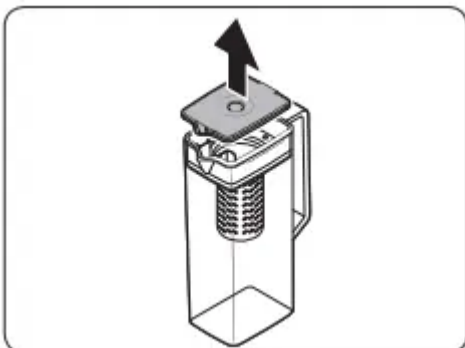

1. Grasp a handle groove of the lid, and then pull up to open the lid.
2. Put tea leaves or fruit to your taste into the infuser.

NOTE If you want to keep the infused water in its initial concentration, turn the AutoFill Pitcher function off.

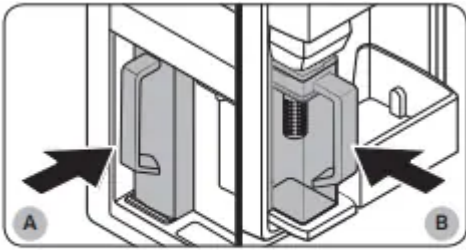

- A. Type A models
- B. Type B models

3. Enable the AutoFill Pitcher function on the control panel. Open the Beverage Center door (Type A) or the left door of the fridge (Type B), and then mount the water pitcher onto the holder. Push it straight in as shown in the figure.

CAUTION Make sure the water pitcher fits in the water pitcher holder.

4. Close the door. The water pitcher will start to fill with chilled water a short time later.

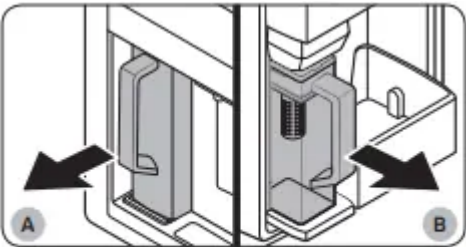

- A. Type A models
- B. Type B models

5. To drink tea, open the Beverage Center door (Type A) or the left door of the fridge (Type B), and then detach the water pitcher. Pull it straight out.

Water dispenser (applicable models only)

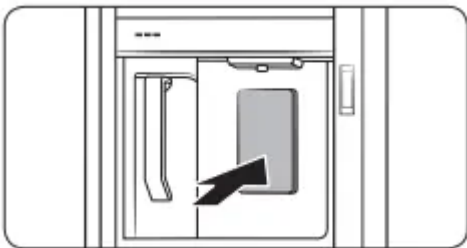

To dispense chilled water, open the Beverage Center and press the dispenser lever.

NOTE

- The dispenser will stop dispensing if you keep pushing the dispenser lever for about 1 minute. To dispense more water, release and push the lever again.
- Make sure the glass is in line with the dispenser to prevent the dispensed water from spilling out.

- If you do not use the water dispenser for 2-3 days, the dispensed water may have an abnormal smell or taste. This is not a system failure. Discard the first 1-2 glasses of water.

Water clouding

Water supplied to the refrigerator flows through a core alkaline filter. During this filtering process, the water pressure of the water increases and the water becomes saturated with oxygen and nitrogen. This causes the water to look misty or cloudy temporarily when dispensed. This is normal and the water will look clear after a few seconds.

Ice maker

The refrigerator has a built-in ice maker that automatically dispenses ice.

- The overall design and/or accessories may differ with the model.

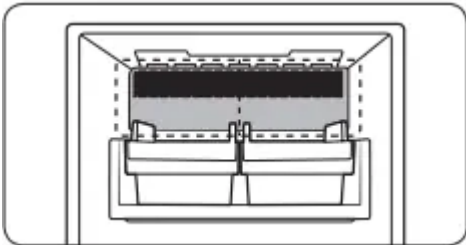

- This product has two types of ice makers.

Ice making

After you have installed your refrigerator and plugged it in, follow these instructions to ensure proper ice making and to keep the ice bucket full of ice.

For first-time use

- Let the ice maker make ice for 1-2 days.
- Discard the first 1-2 buckets of ice to remove impurities in the water supply system.

Diagnosis

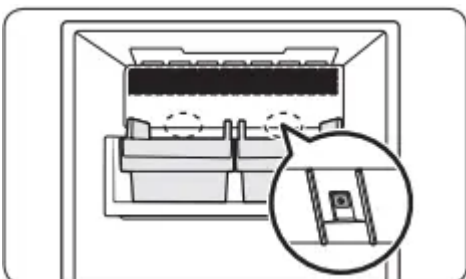

- The overall design and/or accessories may differ with the model.
- If ice does not dispense, first check the status of ice maker using the Test button on the bottom of the ice maker.

- Press the Test button on the bottom of the ice maker. You will hear a chime (ding-dong) when you press the button. You will hear another chime if the ice maker is operating properly.

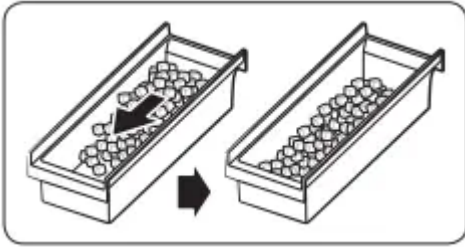

- Ice accumulating on one side of the tray is normal. Arrange the ice evenly in the tray to store more ice.

CAUTION

- Leaving the water line disconnected may cause the water valve to produce a buzzing sound over time. If this is the case, make sure to turn the ice making function (Cubed Ice / Ice Bites) off.
- If the ice making chime rings repeatedly, contact the waterline installer or a local Samsung service center.
- Do not put food in the ice bucket. The frozen food may damage the ice maker, especially when you open or close the door.
- When the refrigerator recovers power after a power failure, the ice bucket may contain a mix of melted and jammed ice cubes, which can prevent the ice maker from working properly. To prevent this, make sure to empty the ice bucket before using the refrigerator.
- Do not put fingers or any objects into the ice maker. This can cause physical injury or property damage.
- Due to sublimation, ice stored in the freezer for a long time gets smaller and then forms large ice chunks. Therefore, if it will be a long time before you use ice, turn the ice maker off as follows.
- Use the new hose-sets supplied with the appliance only. Do not re-use an old hose set.

Maintenance

Handling and care

Ice bucket (applicable models only)

If you do not dispense ice for an extended period, ice may form clumps inside the bucket. If this happens, remove and empty the ice bucket.

CAUTION

- To prevent injury, make sure to clean up any ice or water that has fallen on the floor.

- To prevent accidents or injury, do not let children play with the water dispenser or the ice maker.
- Use only the provided ice bucket. Third-party ice buckets may cause a system failure.

NOTE

- The water pressure required for ice making is between 20 psi and 125 psi (138 and 862 kPa).
- Noise from the ice maker as it produces ice during the ice making process is normal.

AutoFill Pitcher (applicable models only)

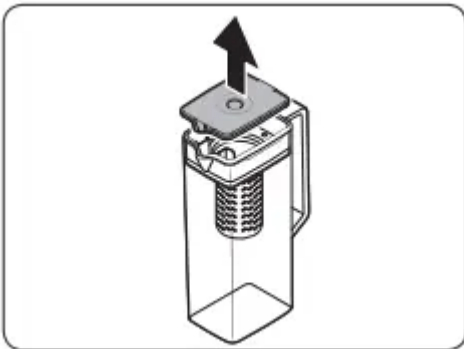

1. Grasp a handle groove of the lid, and then pull up to remove.

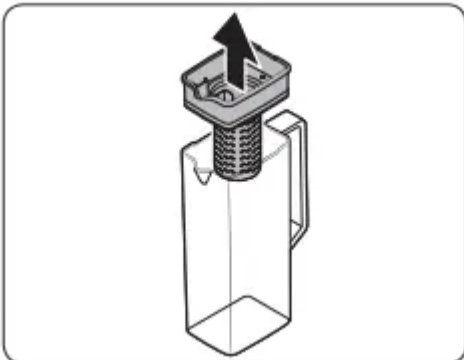

2. Grasp both sides of the infuser holder, and then lift to remove.

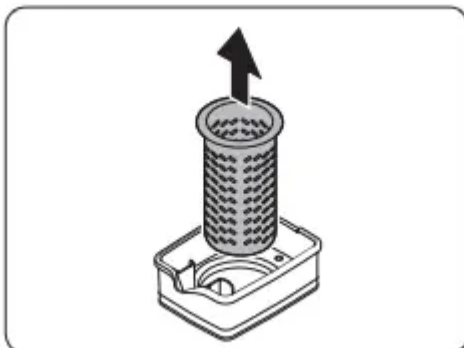

3. While slightly twisting the infuser, pull it out of the sealed mouth.
4. Clean the infuser with neutral agents and running water. Rinse and dry well.

5. Reassemble the AutoFill Pitcher in the reverse order of disassembly.

CAUTION The water pitcher and lid are not dishwasher and microwave safe and can melt or deform if exposed to heat (including hot water). Please hand wash in cool or warm water as needed.

Fridge shelves

The appearance of the shelves differs by model.

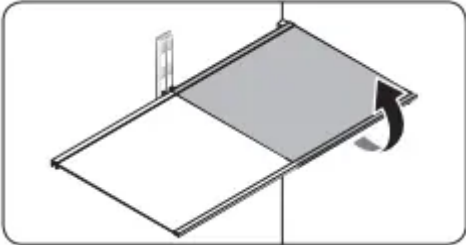

- To remove a shelf, fully open the corresponding door. Hold the front of the shelf, and then gently lift up and pull out.

NOTE Do not lift up the shelf fully when removing or reinserting the shelf. The rear wall of the fridge room can be dented.

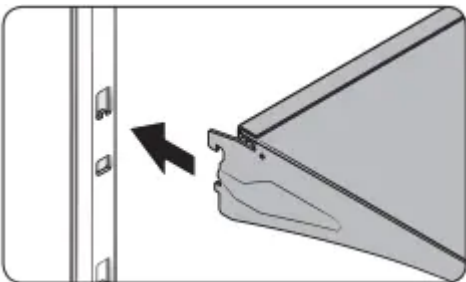

- To reinsert, hold the shelf at an angle so the front is higher than the back, and then insert the top hook into the top shelf notch. Then, lower the shelf and insert the bottom shelf hook into the bottom shelf notch.

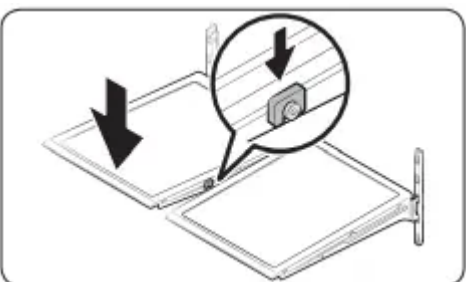

CAUTION

- The tempered glass shelves are heavy. Use caution when removing them.
- The shelf must be inserted correctly. Do not insert upside down.
- Glass containers may scratch the surface of glass shelves.

Door bins

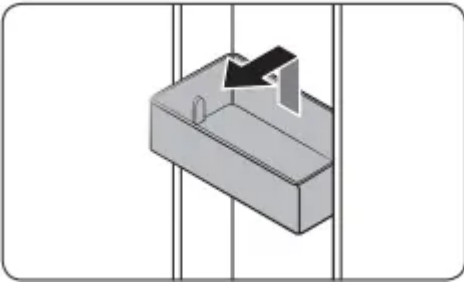

- To remove the door bin, hold the front sides of the bin, and then gently lift up to remove.
- To reinsert, insert the door bin slightly above its final location making sure that the back of the bin is against the door. Hold the rear of the door bin with both hands, and then press down so that it fits snugly.

CAUTION

- Do not remove a bin that is filled with food. Empty the bin beforehand.
- Use caution when opening the door if the bottom bin contains larger bottles, which may fall over.
- Do not allow children to play with the bins. Sharp corners of the bin may cause injury.

Cleaning

Interior and exterior

Regularly use a dry cloth to remove all foreign substances such as dust or water from the power plug terminals and contact points.

1. Unplug the power cord.
2. Use a moistened, soft, lint-free cloth or paper towel to clean the refrigerator's interior and exterior.
3. When done, use a dry cloth or paper towel to dry well.
4. Plug in the power cord.

Dispenser cock (applicable models only)

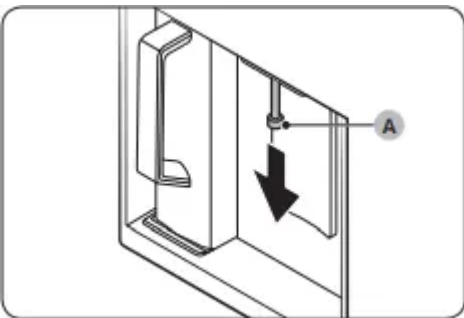

1. Hold the end of the dispenser cock (A).
2. While turning the dispenser cock (A) left, pull it down to remove it from the dispenser.

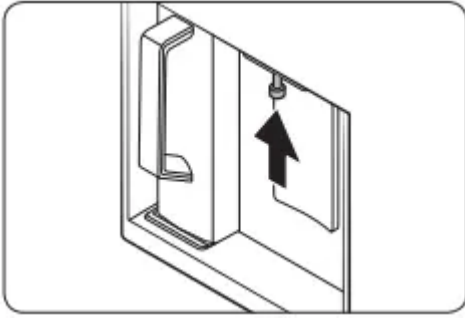

3. Clean the dispenser cock thoroughly, and then assemble it back.

CAUTION

- Fully insert the dispenser cock, so it is back to its original position.
- Do not use a scrub with rough textures for cleaning the dispenser cock.

Troubleshooting

Before calling for service, review the symptoms and recommended solutions below. If none of the suggested solutions resolve your problem, please visit our website at www.samsung.com or call Samsung Customer Care at 1-800-SAMSUNG (726-7864). Note that you will be charged for any service visits in which no defects were found.

General

Temperature

Symptom	Possible causes	Solution
Fridge/freezer does not operate. Fridge/freezer temperature is warm.	<ul style="list-style-type: none"> • Power cord is not plugged in properly. 	<ul style="list-style-type: none"> • Properly plug in the power cord.
	<ul style="list-style-type: none"> • Temperature control is not set correctly. 	<ul style="list-style-type: none"> • Set the temperature lower.
	<ul style="list-style-type: none"> • Refrigerator is located near a heat source or direct sunlight. 	<ul style="list-style-type: none"> • Keep the refrigerator away from direct sunlight or a heat source.
	<ul style="list-style-type: none"> • Not enough clearance between refrigerator and nearby walls or cabinets. 	<ul style="list-style-type: none"> • Make sure there is a gap of at least 2.5 inches (5 cm) between the refrigerator back and sides and any nearby walls or cabinets.
	<ul style="list-style-type: none"> • The refrigerator is overloaded. Food is blocking the refrigerator vents. 	<ul style="list-style-type: none"> • Do not overload the refrigerator. Do not allow food to block vents.
Fridge/freezer is over-cooling.	<ul style="list-style-type: none"> • Temperature control is not set correctly. 	<ul style="list-style-type: none"> • Set the temperature higher.
Interior wall is hot.	<ul style="list-style-type: none"> • Refrigerator has heat-proof piping in the interior wall. 	<ul style="list-style-type: none"> • To prevent condensation from forming, the refrigerator has heat-proof piping in the front corners. If the ambient temperature rises, this equipment may not work effectively. This is not a system failure. 

Odors

Symptom	Possible causes	Solution
Refrigerator has odors.	• Spoiled food.	• Clean the refrigerator and remove any spoiled food.
	• Food with strong odors.	• Make sure strong smelling food is wrapped airtight.

Frost

Symptom	Possible causes	Solution
Frost around the vents.	• Food is blocking the vents.	• Make sure no food blocks the refrigerator vents.
Frost on interior walls.	• Door is not closed properly.	• Make sure food does not block the door. Clean the door gasket.
Fruits or vegetables are frozen.	• Fruits or vegetables are stored in the FlexZone.	• Do not store most kinds of fruit or vegetables in the FlexZone.

Condensation

Symptom	Possible causes	Solution
Condensation forms on the interior walls.	• If door is left open, moisture enters the refrigerator.	• Remove the moisture and do not leave a door open for extended periods of time.
	• Food with high moisture content.	• Make sure food is wrapped airtight.

Water/ice (dispenser models only)

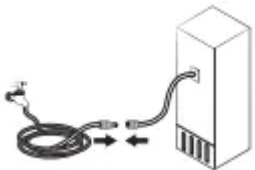
Symptom	Possible causes	Solution
Water flow is weaker than normal.	<ul style="list-style-type: none"> Water pressure is too low. 	<ul style="list-style-type: none"> Make sure the water pressure is between 20 and 120 psi (138 and 827 kPa).
Ice maker makes a buzzing sound.	<ul style="list-style-type: none"> The ice maker function is activated, but the water supply to the refrigerator has not been connected. 	<ul style="list-style-type: none"> Turn off the Ice Maker.
Ice maker does not make ice.	<ul style="list-style-type: none"> Ice maker has just been installed. 	<ul style="list-style-type: none"> You must wait for 12 hours for the refrigerator to make ice.
	<ul style="list-style-type: none"> Freezer temperature is too high. 	<ul style="list-style-type: none"> Set the freezer temperature below 0 °F (-18 °C) or -4 °F (-20 °C) in warm ambient air.
	<ul style="list-style-type: none"> Ice maker is off. 	<ul style="list-style-type: none"> Turn on the ice maker.
Ice does not dispense.	<ul style="list-style-type: none"> Ice may jam if the ice dispenser is not used for a long time (approx. 3 weeks). 	<ul style="list-style-type: none"> If you won't be using the refrigerator for a long time, empty the ice bucket and turn off the ice maker.
	<ul style="list-style-type: none"> Ice bucket is not properly inserted. 	<ul style="list-style-type: none"> Make sure the ice bucket is properly inserted.
	<ul style="list-style-type: none"> Water line is not connected properly or water supply is not on. 	<ul style="list-style-type: none"> Check if the water line is installed correctly. Check if the water line stopcock is closed. 
Water does not dispense.	<ul style="list-style-type: none"> Water line is not connected properly or water supply is not on. 	<ul style="list-style-type: none"> Check if the water line is installed correctly. Check if the water line stopcock is closed.

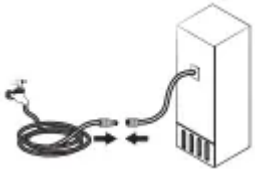
		
	<ul style="list-style-type: none"> • A third-party water filter was installed. 	<ul style="list-style-type: none"> • Use only Samsung-provided or approved filters. • Unapproved filters may leak and damage the refrigerator.
	<ul style="list-style-type: none"> • The "Replace water filter" message appears on the control panel. 	<ul style="list-style-type: none"> • Replace the water filter. Then, on the control panel, go to More Options, and then run Filter Reset.

Do you hear abnormal sounds from the refrigerator?

Before calling for service, review the information below. If you still have questions about sounds your refrigerator is making, please call Samsung Customer Care at 1-800-SAMSUNG (726-7864). Note that you will be charged for any service visits related to normal operating sounds in which no defects were found.

These sounds are normal.

- When starting or ending an operation, the refrigerator may make sounds similar to a car engine ignition. As the operation stabilizes, the sounds will decrease.

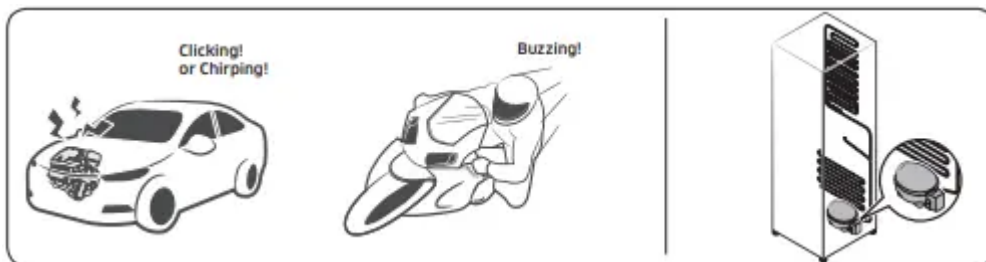

- While the fan is operating, these sounds may occur. When the refrigerator reaches the set temperature, the fan sound will stop.

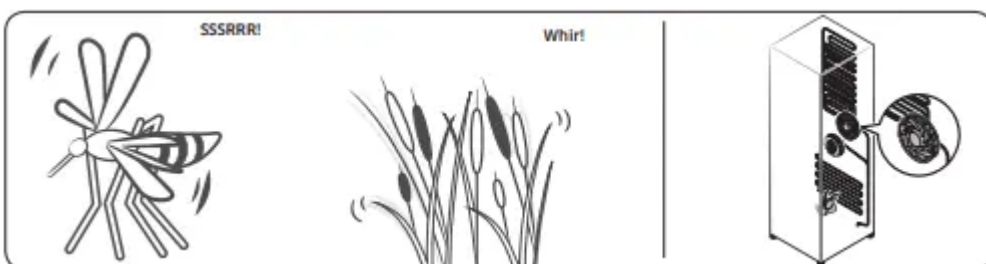

- During a defrost cycle, water may drip on the defrost heater, causing sizzling sounds.

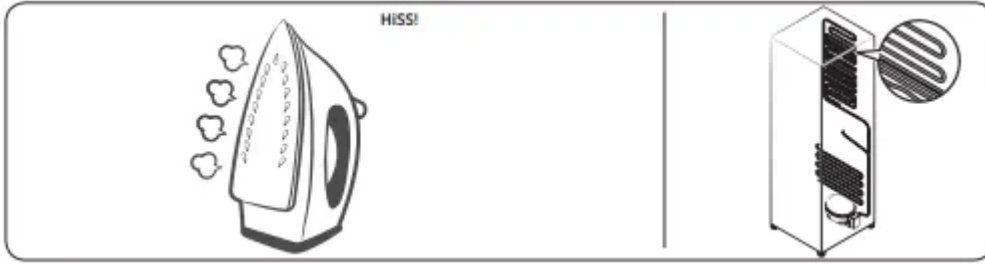

- As the refrigerator cools or freezes, refrigerant gas moves through sealed pipes, causing bubbling sounds.

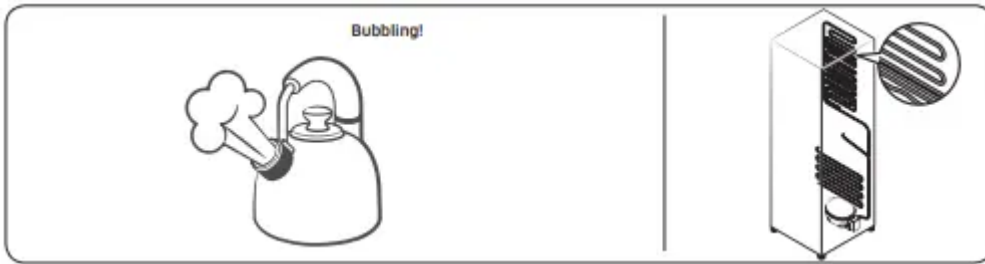

- As the refrigerator temperature increases or decreases, plastic parts contract and expand, creating knocking noises. These noises occur during the defrosting cycle or when electronic parts are working.

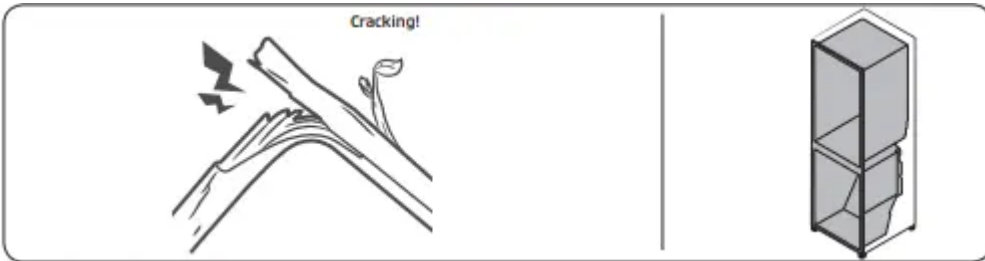

- For ice maker models: When the water valve opens to fill the ice maker, you may hear a buzzing sound.
- Due to pressure equalizing when you open and close the refrigerator door, you may hear a whooshing sound.

SmartThings

Symptom	Action
<p>Could not find “SmartThings” in the app market.</p>	<ul style="list-style-type: none"> • The SmartThings app is not available for some tablet and iPad and some smartphone. <ul style="list-style-type: none"> - support that [Android] OS 6.0 or higher(minimum 2GB RAM Size) - support that [iOS]10.0 or higher/iPhone6 or higher.
<p>The SmartThings app fails to operate.</p>	<ul style="list-style-type: none"> • The SmartThings app is available for applicable models only. • The old Samsung Smart Refrigerator app cannot connect with Samsung Smart Home models.
<p>The SmartThings app is installed but is not connected to my refrigerator.</p>	<ul style="list-style-type: none"> • You must log into your Samsung account to use the app. • Make sure that your router is operating normally. • If the Wi-Fi icon on the refrigerator’s display is off, this indicates that no network connection has been established yet. In this case, use the SmartThings app to connect and register your refrigerator to the access point (AP) of your house.
<p>Could not log into the app.</p>	<ul style="list-style-type: none"> • You must log into your Samsung account to use the app. • If you don’t have a Samsung account, follow the app’s onscreen instructions to create one.
<p>An error message appears when I try to register my refrigerator.</p>	<ul style="list-style-type: none"> • Easy Connection may fail due to the distance from your access point (AP) or electrical interference from the surrounding environment. Wait a moment and try again.
<p>The SmartThings app is successfully connected to my refrigerator but does not run.</p>	<ul style="list-style-type: none"> • Exit and restart the SmartThings app, or disconnect and reconnect the router. • Power off the refrigerator, and then power it on again after 1 minute.



Smart Grid

Symptom	Action
<p>What Do I Need to use the Energy Management and Smart Grid functions?</p>	<ul style="list-style-type: none"> • To use the Smart Grid (Demand Response) and Energy Management function on your Refrigerator, you need the following devices and apps: <ul style="list-style-type: none"> - Devices: 1) A Wireless Router, 2) A SmartThings Refrigerator, 3) A Smartphone. (Recommended: Android OS 6.0 or later version) - Applications: 1) “SmartThings App” from the Goolge Play Store. You also need to: • Connect the Refrigerator and the Smartphone to the same Wi-Fi network in your home. • Install and run the SmartThings App on your Smartphone. • In addition, to use the Smart Grid (Demand Response) function, you must Register for the service with your electric company. The company must have an EMS (Energy Management System) that supports SEP (Smart Energy profile).
<p>Why isn't the Energy Management function working normally?</p>	<ul style="list-style-type: none"> • Confirm that the router in your home and the internet are working properly. <ul style="list-style-type: none"> - Connect a Smartphone to the router (AP, Access Point), and then confirm that you can browse the Internet on the phone. • Confirm that refrigerator is connected to the AP. <ul style="list-style-type: none"> - Check for Wi-Fi icon on the panel of the refrigerator. If the refrigerator is connected, the icon will be on. • Confirm that the refrigerator and Smartphone are connected to the same router.
<p>Why isn't the Delay Defrost Capability working normally?</p>	<ul style="list-style-type: none"> • Confirm that the router in your home and the Internet are working properly. • Connect a Smartphone to the router (AP, Access Point), and then confirm that you can browse the Internet on the phone.



- Confirm that the rear where you live is properly entered into the SmartThings App.
- Confirm that the Smart Grid function works correctly. (Check the control panel. The DAL or TALR icon should not be displayed on the panel.)

Warning

This content is compiled from multiple sources and is provided for reference purposes only. It may not be complete or fully applicable to all situations. If you are unable to resolve your issue, please contact the product manufacturer or an authorized service provider for official support.