

Description

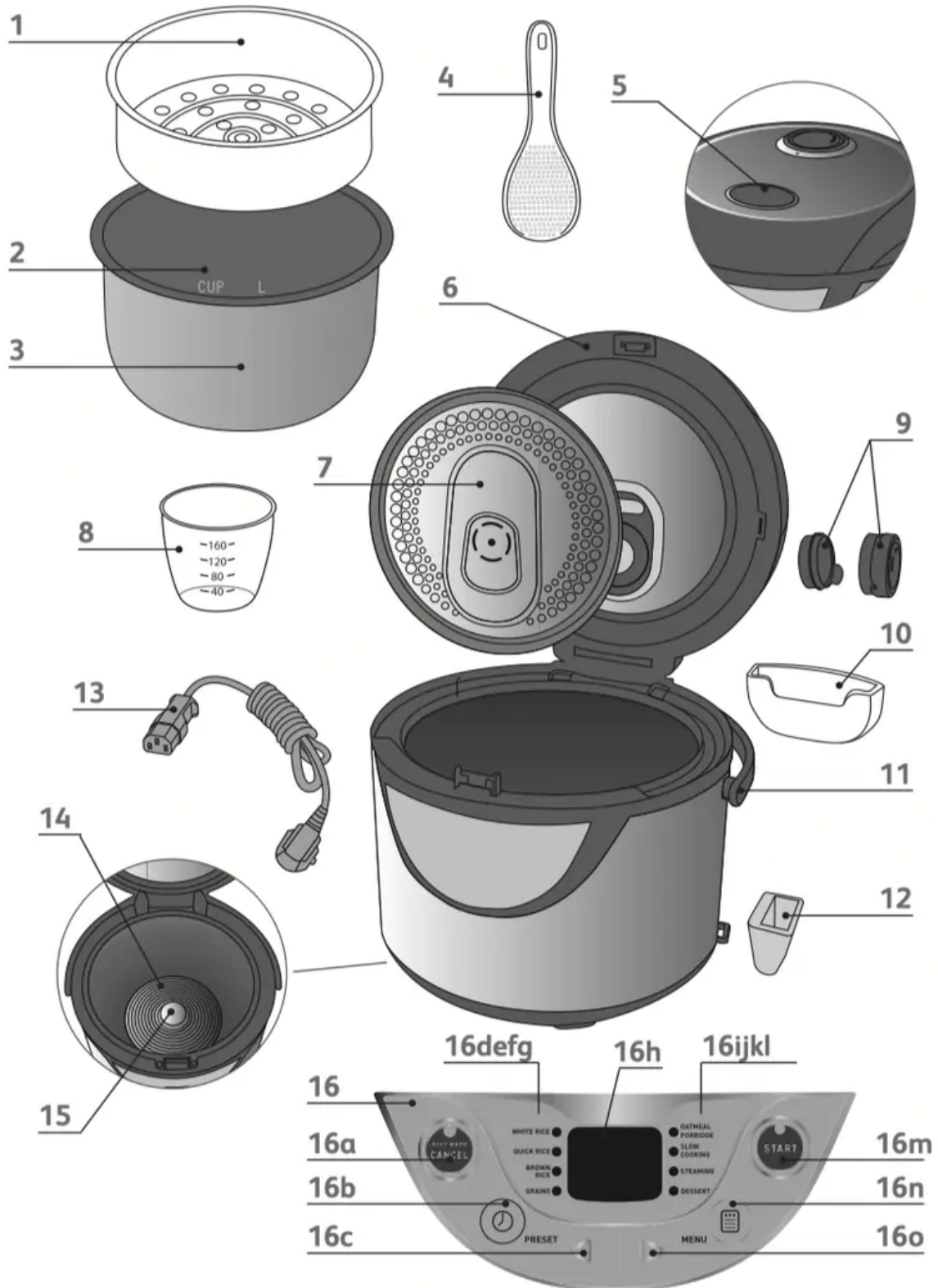

1. Steam basket



2. Water level marks
3. Removable non-stick bowl
4. Rice spoon
5. Lid opening button
6. Lid
7. Inner removable lid
8. Measuring cup
9. Micro pressure valve
10. Condensation collector
11. Handle
12. Spoon support
13. Power cord
14. Heating plate
15. Sensor
16. Control panel
 - a. "KEEP WARM/CANCEL" button (green)
 - b. "PRESET" button
 - c. Decrease time button
 - d. White rice cooking indicator light
 - e. Quick rice cooking indicator light
 - f. Brown rice cooking indicator light
 - g. Grains cooking indicator light
 - h. Display of cooking finish time (with selected programs only) or indication the Keep Warm function is in operation (with selected programs only)
 - i. Oatmeal/Porridge cooking indicator light
 - j. Slow cooking indicator light
 - k. Steam cooking indicator light
 - l. Dessert cooking indicator light
 - m. "START" button
 - n. "MENU" button

- o. Increase time button

Before the first use

Unpack the appliance

- Remove the appliance from the packaging and unpack all the accessories and printed documents.
- Open the lid by pressing the opening button located on the lid – Fig.1.



FIG.1

- Install the spoon support: insert the plastic hook of the support in the hole located at the base of the product, and slide it downwards – Fig.2.

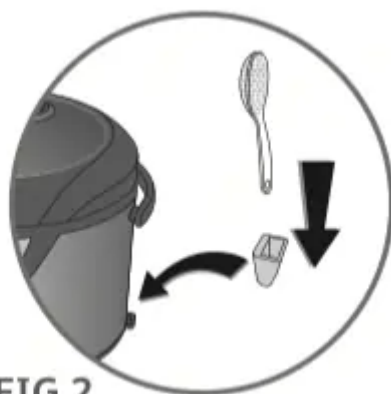

FIG.2

Read the instructions and carefully follow the operating method.

Clean the appliance

- Remove the non-stick bowl, the inner removable lid and the micro pressure valve. To remove the inner lid, press the release clip on the right side to release the lid – Fig.3.



FIG.3

- After removing the inner lid, push up the micro-pressure valve through the hole on the underside of the lid with a finger – Fig.4. To separate the upper and lower parts of the micro-pressure valve, rotate the valve in the unlocking direction by turning the upper triangle until it is aligned with the open padlock symbol then separate – Fig.5 and Fig.6.



FIG.4

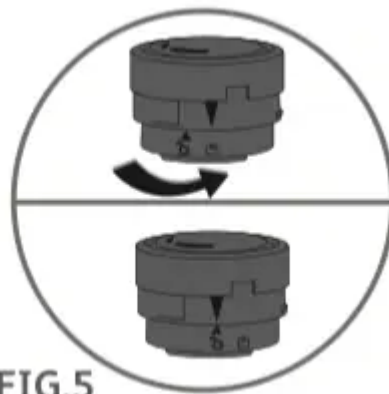

FIG.5

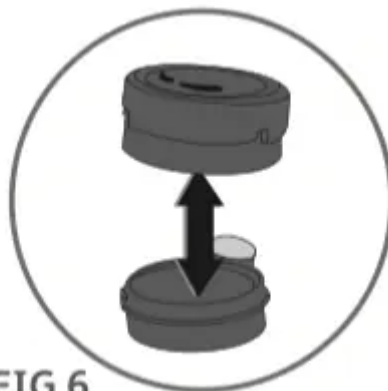

FIG.6

- Clean the bowl, the inner removable lid, the micro pressure valve and all the accessories with a sponge and washingup liquid. Wipe the outside of the appliance and the metal parts of the lid with a damp cloth.
- Dry carefully.

- The non-stick bowl, the steam basket, the condensation collector, the spoon and the cup are dishwasher safe.
- Replace the micro-pressure valve. Align the upper triangle with unlocked padlock of the micropressure valve to close up the two parts, then rotate in locking direction until the upper triangle is aligned with the locked padlock which indicates the two parts are locked, then re-fit the micropressure valve down into the lid – Fig.7. Make sure that the triangle in the micropressure valve is aligned with the triangle on the lid and firmly push down until it fits in place.



FIG.7

- Replace the inner removable lid by fitting the tab on the left side into the slot on the lid, then push in the lid until it the tab on the right clicks into place. The wider side of the seal must be uppermost when fitting the lid.

Using your rice cooker

For all 8 functions

- Carefully wipe the outside of the bowl (especially the bottom). Make sure that there are no foreign residues or liquid underneath the bowl and on the heating plate – Fig.8.

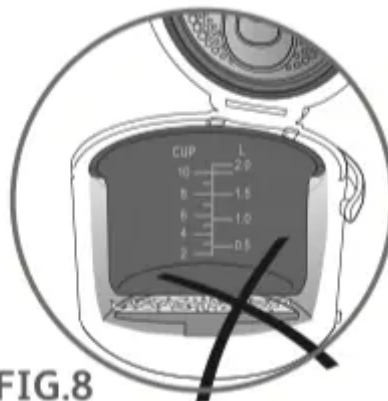

FIG.8

- Place the bowl into the appliance – Fig.9, making sure that it is correctly positioned.



FIG.9

- Slightly rotate the bowl in both directions, so as to ensure good contact between the bottom of the bowl and the heating plate.
- Check that the condensation collector is correctly placed in position, if not, please install it by pushing firmly into the groove – Fig.10.



FIG.10

- Close the lid.
- Insert the power cord connector into the base of the appliance. Check it is firmly pushed in.
- Plug in the appliance. It will make a long "Beep" sound, the digital screen and indicator lights will flash once, then the digital screen will display "--". It indicates the rice cooker has entered the standby mode and is ready for function selection.
- Do not switch on the appliance until all of the above stages have been completed.
- Do not switch on the appliance with an empty cooking bowl.
- Do not touch the heating plate when the product is plugged.

Never place your hand on the micro pressure valve during cooking, as there is a danger of burns.

If you wish to change the selected cooking menu, press "CANCEL" button and choose the program you want. Only use the inner bowl provided with the appliance.

Do not pour water or put ingredients in the appliance without the bowl inside.

SUMMARY OF PROGRAMS AND FUNCTIONS			
Program	Delayed start (Preset)	Simmering phase (+ simmering time)	Keep Warm*
White rice	YES	YES - 14 min	YES
Quick rice	YES	YES - 10 min	YES
Brown rice	YES	YES - included in the cooking time	YES
Grains	YES	YES - 10 min	YES
Oatmeal/ Porridge	YES	YES - 10 min	YES
Slow cooking	NO	NO	YES
Steaming	YES	NO	YES
Dessert	NO	NO	YES

* "Keep Warm" remains on continuously for 24 hours then the system will automatically cancel the "Keep Warm" function and return to standby mode.

Rice Cooking

Measuring the ingredients - Max capacity of the bowl

The rice cooker itself determines the exact cooking time depending on the quantity of water and ingredients placed in the bowl (see cooking table below for a guide to times).

- The graduated markings on the inside of the bowl are given in litres and cups, these are used for measuring the amount of water when cooking rice – Fig.11.



FIG.11

- The plastic cup provided with your appliance is for measuring rice and the table states the quantity of rice required for the number of servings. 1 level measuring cup of rice weighs about 150 g.
- For best results, we recommend using ordinary rice rather than "easy cook" type rice which tends to give a stickier rice and may adhere to the base.
- To cook 1 cup of white rice (serves 2 small or 1 large portion), use 1 measuring cup of white rice and then add one and a half measuring cup of water. With some types of rice it is normal for a little rice to stick on the base when cooking 1 cup of rice. For best results cook 2 or more cups of rice.
- The maximum quantity of water + rice should not exceed the 10 cup mark inside the bowl – Fig.11.



FIG.11

- The cooking times given in the tables are only approximate and for your guidance.
- Place the appliance on a flat, stable, heat-resistant work surface away from water splashes and any other sources of heat.
- Measure the rice using the plastic measuring cup provided and rinse thoroughly in cold water before cooking.
- Pour the rice into the bowl. Then fill with cold water up to the corresponding "CUP" mark printed in the bowl (See cooking guide below) – Fig.12.





- Close the lid.

Note: Always add the rice first otherwise you will have too much water.

COOKING GUIDE FOR WHITE RICE -10 CUPS MODEL				
Measuring cups of white rice	Weight of white rice	Water level in the bowl (+ the rice)	Serves	Approximative cooking time*
2	300 g	2 cup mark	3-4	42 min
4	600 g	4 cup mark	5-6	46 min
6	900 g	6 cup mark	8-10	50 min
8	1200 g	8 cup mark	13-14	55 min
10	1500 g	10 cup mark	16-18	60 min

* The rice cooker will automatically determine the cooking time depending on the quantity of rice and water placed in the bowl. The cooking phase is automatically followed by a simmering phase.

Cooking with delayed start - "Preset" function

- It is possible to delay the cooking start time.
- Press "Menu" button until the indicator light of the required function turns on ; then press "Preset" button, and the digital screen will display the minimum preset time for the selected program (the preset time flickers, indicating preset time is not selected yet) – Fig.13. Press   to set required preset time and then press "Start" button (preset time will include

cooking time, i.e. it will end cooking when the preset time is over) – Fig.14. Each press will increase or decrease the preset time of one hour.



- After cooking, the "Keep Warm" indicator light will turn on and beep several times and the digital screen will display "b", indicating it's time to open the lid and serve the food – Fig.15.

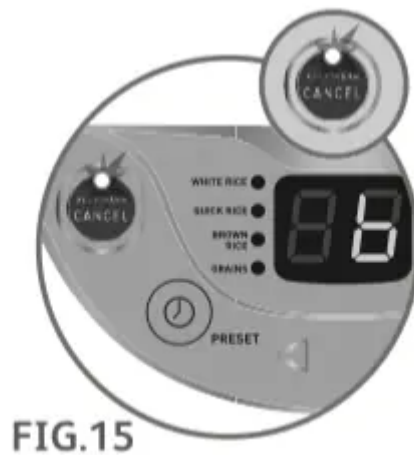

- The maximum preset time is 15 hours. After reaching 15 hours, it will return to the default minimum preset hours.

Cooking with delayed start is for the following programs only: White rice, Quick rice, Grains, Brown rice, Oatmeal/Porridge, Steaming.

White rice cooking

The simmer phase is to absorb the left moisture.

- The delayed start function can be used for the "White Rice" program, with a delayed time range of between 2 to 15 hours.
- Press "Menu" button while in standby mode until the "white rice" indicator light turns on, the digital screen will display "--" and the "Start" indicator light will flicker – Fig.16. Press the

"Start" button, the cooker will enter "White rice" cooking mode, the "Start" indicator light will remain on and the digital screen will display "--" – Fig.17.



FIG.16

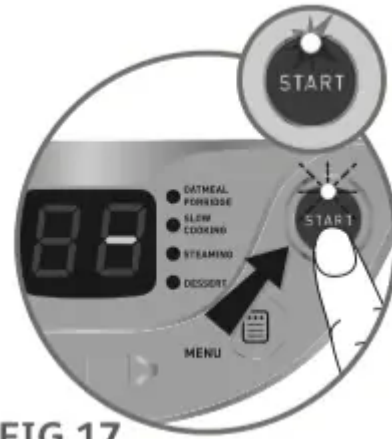

FIG.17

- When the inner bowl is dry, the buzzer will beep twice and enter into the simmer phase for 14 minutes. The screen displays countdown of 14 minutes.
- After the countdown, the "Keep Warm" indicator light will turn on and the cooker will beep for several times and the digital screen will display "b". Open the lid ; stir the rice with the rice spoon to separate grains. The cooked rice can either be served immediately or kept warm for a proper duration – Fig.15.



FIG.15

Quick rice cooking

- The "Quick rice" Function is for cooking white rice only. The delayed start function can be used for the "Quick Rice" program, with a delayed time range of between 2 to 15 hours.
- Press "Menu" button while in standby mode until the "Quick rice" indicator light turns on, the digital screen will display "--" and the "Start" indicator light will flicker – Fig.18. Press the "Start" button, the cooker will enter "Quick rice" cooking mode, the "Start" indicator light will remain on and the digital screen will display "--" – Fig.17.



FIG.18

- When the inner bowl is dry, the buzzer beeps for several times, the digital screen will display "10", indicating the 10 minutes countdown for automatic simmering.
- After the countdown, the "Keep Warm" indicator light will turn on and the cooker will beep for several times and the digital screen will display "b". Open the lid ; stir the rice with paddle to avoid lumping. The cooked rice can either be served immediately or kept warm for a proper duration – Fig.15.
- This function features a shorter cooking time and is convenient for users who are in a hurry.
- After each use empty and clean the condensation collector.

Brown rice cooking

To cook brown rice

- The delayed start function can be used for the "Brown Rice" program, with a delayed time range of between 2 to 15 hours.
- Press "Menu" button while in standby mode until the "Brown rice" indicator light turns on, the digital screen will display "90" and the "Start" indicator light will flicker – Fig.19. Press the "Start" button, the cooker will enter "Brown rice" cooking model, the "Start" indicator light will remain on and the digital screen will display the countdown time – Fig.17.
- There is a simmering phase. The simmering time is already included in the 90 minutes cooking time.
- After simmering, the "Keep Warm" indicator light will turn on, the buzzer will beep several times and the digital screen will display "b". The cooker will enter "Keep Warm" phase – Fig. 15.

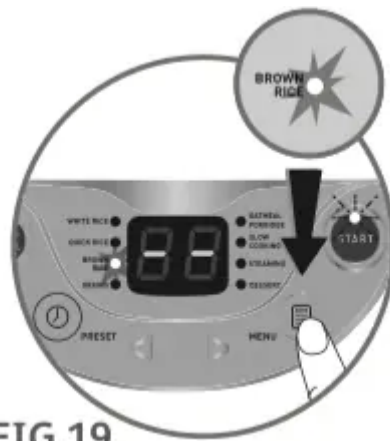

FIG.19

Some recommendations for best results when cooking rice

- Measure out the rice and rinse it thoroughly under running water in a sieve for a long time (except for risotto rice which should not be rinsed). Then place the rice in the bowl together with the corresponding quantity of water.
- Make sure that the rice is well distributed around the whole surface of the bowl, in order to allow even cooking.
- Add salt to your personal taste if required.
- Water may be substituted for stock. If using stock, there is the risks of rice browning a bit on the bottom.
- Do not open the lid during cooking as steam will escape and this will affect the cooking time and the taste.

Grains

Cooking To cook grains

- The delayed start function can be used for the "Grains" program, with the delayed time range of between 2 to 15 hours.
- Press "Menu" button while in standby mode until the "Grains" indicator light turns on, the digital screen will display "--" and the "Start" indicator light will flicker – Fig.20. Press the "Start" button, the cooker will enter "Grains" cooking mode, the "Start" indicator light will remain on and the digital screen will display "-" – Fig.17.
- When the inner bowl is dry, the buzzer beeps twice, the digital screen will display "10", indicating the 10 minutes countdown for automatic simmering.
- After simmering, the "Keep Warm" indicator light will turn on, the cooker will beep for several times and the digital screen will display "b". Open the lid ; stir the grains with paddle to separate the grains. The cooked grains can either be served immediately or kept warm for a proper duration – Fig.15.

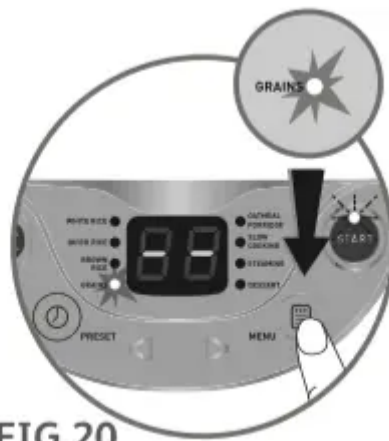

FIG.20

This program is suitable for Couscous, Bulgur Wheat, Polenta, Quinoa, Millet...

For the 10 cups model, do not exceed 5 cups of grains.

Put twice quantity of water compared to the grains you put.

Oatmeal/Porridge Cooking

To cook oatmeal or porridge

- The preset time function can be used for the "Oatmeal/Porridge" program, with a delayed time range of between 2 to 15 hours.
- Press "Menu" button while in standby mode until the "Oatmeal/Porridge" cooking indicator light turns on, the digital screen will display "--" and the "Start" indicator light will flicker – Fig. 21. Press the "Start" button, the cooker will enter "Oatmeal/Porridge" cooking model, the "Start" indicator light will remain on and the digital screen will display "-" – Fig.17.
- When the water in the inner bowl gets to boiling temperature, the buzzer beeps for two times and the digital screen will display "10", indicating the cooker starts to count down from 10 minutes.
- At the end of the countdown, the "Keep Warm" indicator light will turn on, the cooker will beep several times and the digital screen will display "b". The cooker will enter "Keep Warm" status – Fig.15.

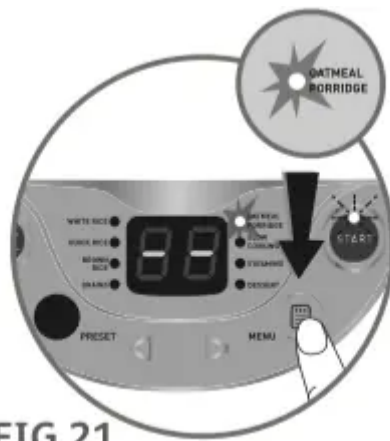

FIG.21

Slow Cooking

To slow cook

- The delayed start time is not available for the "Slow Cooking" Function.
- Press "Menu" button while in standby mode until the "Slow cooking" indicator light turns on, the digital screen will display "60" and the "Start" indicator light will flicker – Fig.22. The time can be adjusted from 60 minutes to 9 hours in hourly intervals.
- Press the "Start" button, the "Start" indicator light will remain on and the digital screen will display the countdown time in hourly intervals and after 60 minutes in 1 minute – Fig.17.
- At the end of the countdown, the "Keep Warm" indicator light will turn on, the cooker will beep several times and the digital screen will display "b". The cooker will enter "Keep Warm" mode – Fig.15.

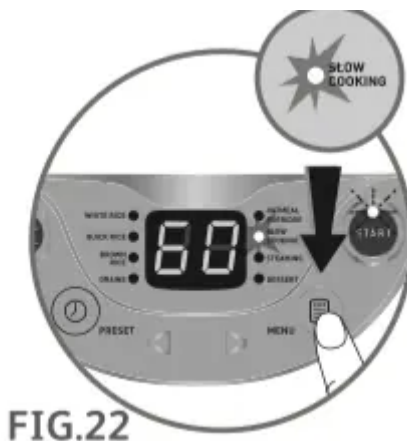

FIG.22

Steaming (for vegetables, fish and fruit)

- The maximum quantity of water in the bowl should not exceed the maximum CUP mark shown in "CUP" on the bowl – Fig.11. Exceeding this level may cause overflows during use.
- The water should be lower than the steam basket.

- Filling with water to the 2 cup mark is sufficient for about 30 minutes cooking on steam program.
- Add the ingredients in the steam basket.
- Place the steam basket in the bowl – Fig.23.



FIG.23

- The delayed start function is available for the "Steam" program, with a delayed time range of between 2 to 15 hours.
- Press "Menu" button while in standby mode until the "Steam" indicator light turns on, the digital screen will display default cooking time "1" and the "Start" indicator light will flicker – Fig.24. Press the "Start" button to enter "Steam" cooking mode if there is no need for a delayed start, the digital screen will display "1" – Fig.25.

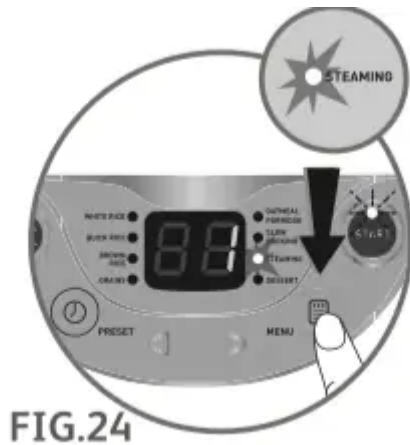

FIG.24



FIG.25

- If a delayed start has been selected, the digital screen will display the countdown of the preset time in cooking mode.
- After cooking, the buzzer will beep for several times, the "Keep Warm" indicator light will turn on and the digital screen will display "b", indicating the rice cooker enters "Keep Warm" mode – Fig.15. Open the lid ; the cooked preparation can either be served immediately or kept warm for a short time – Fig.15.

Dessert Cooking

To cook dessert

- The delayed start function time is not available for the "Dessert" Function.
- The dessert function is suitable for cooking sponge cakes.
- Press "Menu" button while in standby mode until the "Dessert" indicator light turns on, the digital screen will display "--" and the "Start" indicator light will flicker – Fig.26. Press the "Start" button, the cooker will enter "Dessert" cooking mode, the "Start" indicator light will remain on and the digital screen will display "-" – Fig.17.



FIG.26

- The dessert function remains on continuously for 45 minutes then the "Keep Warm" function will turn on. After cooking, the buzzer will beep for several times, the "Keep Warm" indicator light will turn on and the digital screen will display "b", indicating the rice cooker enters "Keep Warm" status – Fig.15.

Automatic keep warm function

Starting your rice cooker in keep warm mode must only be used for hot food.

- The preset of time is not available for the "Keep Warm/Cancel" Function.
- Press "Keep Warm/Cancel" button while in standby mode, the "Keep Warm/Cancel" indicator light turns on and the digital screen will display "b", indicating the cooker enters keep-warm mode – Fig.15.
- Press "Keep Warm/Cancel" button while a program is set or a function is in working mode to cancel it and return to standby mode.
- If the cooker remains on "Keep Warm" continuously for 24 hours, the system will automatically cancel "Keep Warm" function and return to standby mode.
- The "Keep Warm" function should not be used for reheating food.

Power failure backup (short memory function)

- The cooker has a "short memory" function in case of power cuts of 3 to 10 seconds. When the power returns, the cooker returns automatically to its original setting and continues to cook. In case of long power cuts, the cooker will return to the standby mode.

On completion of cooking

The escaping steam is very hot.

Never remove the bowl after cooking without protective oven gloves.

- Open the lid.
- Serve the food using the plastic spoon supplied with the appliance and close the lid.
- The food remaining in the bowl will keep warm for any further servings.
- Don't forget to press "CANCEL" button after keep warm and unplug the appliance.

Cleaning and Maintenance

Condensation collector

- The condensation collector should be emptied and cleaned after each use.
- To remove the collector, press on each side of the plastic cover and remove – Fig.27.
- To put the condensation collector back, push firmly into the seating.



Bowl, condensation collector, micro pressure valve and the steam basket

- After removing the inner lid, push up the micro-pressure valve through the lid hole with finger from underside of the lid – Fig.4, rotate the micro-pressure valve in unlocking direction until the upper triangle is aligned with the opened padlock and finally separate the upper and lower parts of the micro-pressure valve – Fig.5.

- Unplug the appliance before removing the bowl. Use hot water, washing up liquid and a sponge to clean the bowl – Fig.28, the condensation collector – Fig.28, the micro pressure valve – Fig.29, the inner removable lid – Fig.30, the spoon and the cup. Scouring powders and metal sponges are not recommended.
- If food has stuck to the bottom, allow the bowl to soak for a while before washing it.
- The non-stick bowl, the steam basket, the condensation collector, the spoon and the cup are dishwasher safe.
- Dry the bowl carefully.
- Do not immerse the appliance in water, or pour water into it the interior of the appliance body.

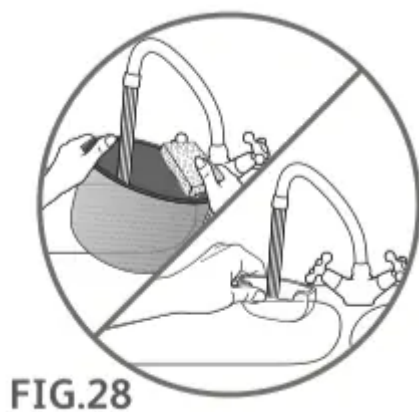

FIG.28

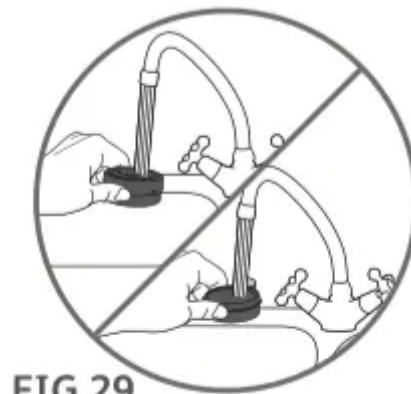

FIG.29

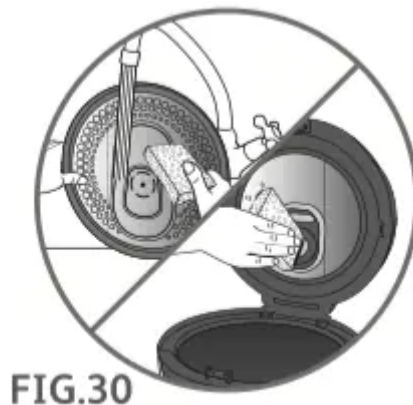

FIG.30

Taking care of the bowl

- To avoid damaging the non-stick coating of the bowl do not cut food in the it.
- Use plastic or wooden utensils and not metal ones when stirring or serving food to avoid damaging the bowl surface.
- To avoid any risk of corrosion, do not pour vinegar into the bowl.
- The colour of the bowl surface may change after using for the first time or after a long period of use. This change in colour is due to the action of steam and water and does not

have any effect on the use of the Rice Cooker, nor is it dangerous for your health. It is perfectly safe to continue using it.

- Do not use a handblender directly in the non-stick bowl to blend foods.

Cleaning and care of the other parts of the appliance

Let cool the product.

- Unplug the appliance before cleaning.
- Clean the outside of the Rice Cooker, the inside of the lid – Fig.30 and the cord with a damp cloth and wipe dry. Do not use abrasive products.
- Do not use water to clean the interior of the appliance body as it could damage the heat sensor.

Technical troubleshooting guide

Malfunction description	Causes	Solution
LED screen indicates "E0".	Top major sensor open circuit or short circuit.	Send to Authorized Service Centre for repair.
LED screen indicates "E1".	<ul style="list-style-type: none"> • No bowl. • Bottom major sensor open circuit or short circuit. 	<ul style="list-style-type: none"> • Place the bowl into the appliance. Then plug in the appliance. • After replacing bowl is display still shows E1 send to Authorized Service Centre for repair.
The indicator lights are not illuminated and appliance is not heating.	Rice cooker not plugged in.	Check the power cord is firmly engaged in the rice cooker and the appliance is plugged in at the mains socket.
The indicator light is not illuminated and appliance is heating.	A problem with the internal connection of the indicator light or the indicator light is damaged.	Send to Authorized Service Centre for repair.
Steam leakage during use.	Lid is badly closed.	Open and close the lid again.
	Micropressure valve not well positioned or assembled incorrectly.	Stop the cooking (unplug the product) and check the valve is assembled correctly (2 parts locked together) and well positioned.
	Lid or micropressure valve gasket is damaged.	Send to Authorized Service Centre for repair.
Rice not fully cooked or over cooked.	Not enough or too much water compared to rice quantity.	Refer to instructions for water quantity.

<p>Automatic Keep Warm function fails (appliance stays on cooking program or does not heat on Keep Warm).</p>		<p>Send to Authorized Service Centre for repair.</p>
<p>Water leakage on the work surface.</p>	<p>Condensation collector missing or condensation collector overflow.</p>	<p>Empty the condensation collector after each use and check it is correctly positioned.</p>

Remark: if inner bowl is damaged, do not use it anymore and get a replacement from the Authorized Service Centre for repair.

Warning

This content is compiled from multiple sources and is provided for reference purposes only. It may not be complete or fully applicable to all situations. If you are unable to resolve your issue, please contact the product manufacturer or an authorized service provider for official support.

