

IMPORTANT SAFETY INSTRUCTIONS

READ ALL SAFETY WARNINGS AND INSTRUCTIONS BEFORE USING THIS PRODUCT.

WARNING: When using an electrical product, basic precautions should always be followed to avoid electric shock, fire, and/or serious injury, including the following:

- Fully assemble before operating.
- Operate cleaner only at voltage specified on data plate on back of cleaner.
- Do not leave product when plugged in. Unplug from outlet when not in use and before servicing.
- Do not use outdoors or on wet surfaces.
- Do not allow to be used as a toy. Not intended for use by children age 12 and under. Close supervision is necessary when used by or near children. To avoid injury or damage, keep children away from product, and do not allow children to place fingers or other objects into any openings.
- Use only as described in this user's manual. Use only HOOVER® recommended attachments.
- Do not use product with damaged cord or plug. If product is not working as it should, has been dropped, damaged, left outdoors, or dropped into water, call customer service at 1-800-944-9200 prior to continuing use.
- Do not pull or carry by cord, use cord as a handle, close a door on cord, or pull cord around sharp edges or corners. Do not run appliance over cord. Keep cord away from heated surfaces.
- Do not unplug by pulling on cord. To unplug, grasp the plug, not the cord.
- Do not handle plug or appliance with wet hands.
- Do not put any object into openings. Do not use with any opening blocked; keep free of dust, lint, hair, and anything that may reduce air flow.
- Keep hair, loose clothing, fingers, and all parts of body away from openings and moving parts.
- Turn off all controls before unplugging.
- Use extra care when cleaning on stairs. To avoid personal injury or damage, and to prevent the cleaner from falling, always place cleaner at bottom of stairs or on floor. Do not place cleaner on stairs or furniture, as it may result in injury or damage.
- Do not use to pick up flammable or combustible liquids, such as gasoline, or fine wood sandings, or use in areas where they may be present.

- Unplug before connecting Turbo Tool.
- Do not pick up anything that is burning or smoking, such as cigarettes, matches, or hot ashes.
- Do not use without separator, filters, or dirt cup in place.

CAUTION: TO REDUCE THE RISK OF DAMAGE:

- Avoid picking up hard, sharp objects with this product, as they may cause damage
- Store appropriately indoors in a dry place. Do not expose machine to freezing temperatures.
- Brush roll continues to turn while product is turned on and handle is in upright position. To avoid damage to carpet, rugs, and flooring, avoid tipping cleaner or setting it on furniture, fringed area rugs, or carpeted stairs during tool use.
- Do not use sharp objects to clean out hose as they can cause damage.
- With brush roll on, do not allow cleaner to sit in one location for an extended period of time, as damage to floor can result.

WARNING: TO REDUCE THE RISK OF ELECTRIC SHOCK, THIS APPLIANCE HAS A POLARIZED PLUG (ONE BLADE IS WIDER THAN THE OTHER). THIS PLUG WILL FIT IN A POLARIZED OUTLET ONLY ONE WAY. IF THE PLUG DOES NOT FIT FULLY IN THE OUTLET, REVERSE THE PLUG. IF IT STILL DOES NOT FIT, CONTACT A QUALIFIED ELECTRICIAN TO INSTALL THE PROPER OUTLET. DO NOT CHANGE THE PLUG IN ANY WAY.

WARRANTY

LIMITED WARRANTY FOR HOOVER® PRODUCT / FIVE YEAR LIMITED WARRANTY (DOMESTIC USE)

If this product is not as warranted, contact TTI Floor Care North America Customer Service at 1-800-944- 9200. Please have available the proof of purchase and model number for the warranted product.

WHAT THIS WARRANTY COVERS:

This limited warranty provided by Royal Appliance Mfg. Co., doing business as TTI Floor Care North America (referred to hereafter as “Warrantor”) applies only to products purchased in the U.S. (including its territories and possessions), a U.S. Military Exchange, or Canada. When used and maintained in normal household use and in accordance with the Owner’s Guide, this product is warranted against original defects in material and workmanship for FIVE years from the date of original purchase (the “Warranty Period”). If Warrantor determines that the issue you are experiencing is covered under the terms of this warranty (a “covered warranty claim”), we will, at our sole discretion and free of charge (subject to the cost of shipping), either (i) repair your



product; (ii) ship you a replacement product, subject to availability; or (iii) in the event that the applicable parts or replacement are not reasonably available, ship you a similar product of equal or greater value. In the unlikely event that we are unable to repair your product or ship a replacement or similar product, we reserve the right, at our sole discretion, to issue you a refund or store credit (if applicable) of the actual purchase price at the time of the original purchase as reflected on the original sales receipt. Parts and replacements may be new, refurbished, lightly used, or remanufactured, in Warrantor's sole discretion.

WHO THIS LIMITED WARRANTY COVERS:

This limited warranty extends only to the original retail purchaser, with original proof of purchase from Warrantor or an authorized dealer of Warrantor products, in the U.S., U.S. Military Exchanges, and Canada.

WHAT THIS WARRANTY DOES NOT COVER:

This warranty does not cover use of the product in a commercial operation (such as maid, janitorial, and equipment rental services, or any other incomegenerating activity); improper maintenance of the product; the product if it has been subject to misuse, negligence, neglect, vandalism, or the use of voltages other than that on the data plate of this product. This warranty does not cover damage resulting from an act of God, accident, owner's acts or omissions, service of this product by other than Warrantor or a Warrantor authorized service provider (if applicable), or other acts beyond the control of Warrantor. This warranty also does not cover use outside the country in which the product was initially purchased, or resale of the product by the original owner. Pick-up, delivery, transportation, and house calls are not covered by this warranty. In addition, this warranty does not cover any product that has been altered or modified, or repairs made necessary by normal wear or the use of other products, parts, or accessories which are either incompatible with this product or adversely affect this product's operation, performance, or durability. Normal wear items are not covered under this warranty. Depending on the product, normal wear items may include, but are not limited to, belts, filters, brush rolls, blower fans, blower and vacuum tubes, and vacuum bags and straps.

OTHER IMPORTANT TERMS:

This warranty is not transferable and may not be assigned; any assignment made in contravention of this prohibition is void. This warranty shall be governed and construed under the laws of the state of North Carolina. The Warranty Period will not be extended by any replacement of batteries, parts, or products or by virtue of any repair performed under this warranty.

THIS LIMITED WARRANTY IS THE EXCLUSIVE WARRANTY AND REMEDY, AND ALL EXPRESS AND IMPLIED WARRANTIES OTHER THAN THE LIMITED WARRANTY SET FORTH ABOVE, INCLUDING IMPLIED WARRANTIES OF MERCHANTABILITY AND FITNESS FOR A PARTICULAR PURPOSE, ARE EXPRESSLY DISCLAIMED. IN NO EVENT WILL WARRANTOR BE LIABLE FOR ANY SPECIAL, INDIRECT, INCIDENTAL OR CONSEQUENTIAL DAMAGES OF ANY KIND OR NATURE TO OWNER OR ANY PARTY CLAIMING THROUGH OWNER,



WHETHER BASED IN CONTRACT, NEGLIGENCE, TORT, OR STRICT PRODUCTS LIABILITY OR ARISING FROM ANY CAUSE WHATSOEVER, EVEN IF THIS WARRANTY FAILS OF ITS ESSENTIAL PURPOSE. TO THE EXTENT PERMITTED BY APPLICABLE LAW, NO WARRANTIES THAT ARISE BY OPERATION OF LAW, IF APPLICABLE, SHALL EXCEED THE DURATION OF THE LIMITED WARRANTY PROVIDED HEREIN. Warrantor's liability for damages to you for any costs whatsoever arising out of this statement of limited warranty shall be limited to the amount paid for this product at the time of original purchase.

Some states do not allow the exclusion or limitation of incidental or consequential damages, disclaimers of implied warranties, or limitations on the duration of implied warranties, so the above exclusions, disclaimers, and/or limitations may not apply to you. This warranty gives you specific legal rights, and you may also have other rights, which vary from state to state.

GENUINE PARTS AND ACCESSORIES:

We recommend using only with genuine HOOVER® parts, and accessories. Damage caused by use with other than genuine HOOVER® parts, and accessories is not covered by and may void your warranty

ASSEMBLY

Fully assemble product prior to use.

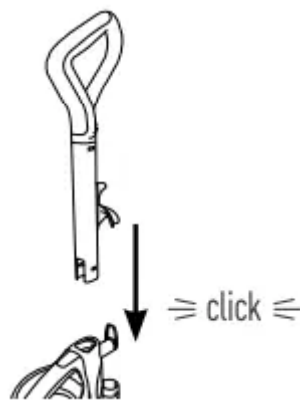

1 Insert handle into body of vacuum until it clicks.

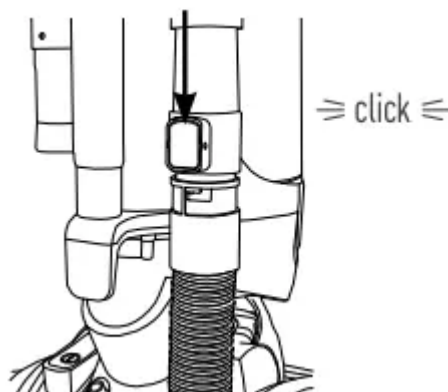

2 Insert hose into hose port. It will click when secured.

OPERATION

CAUTION:Not to be used for grooming a pet.

CAUTION:Use extra care when cleaning on stairs. To avoid personal injury or damage, and to prevent the cleaner from falling, always place cleaner at the bottom of the stairs or on the floor. Do not place cleaner on stairs or furniture, as it may result in injury or damage. When using tools, always ensure handle is in the upright position.

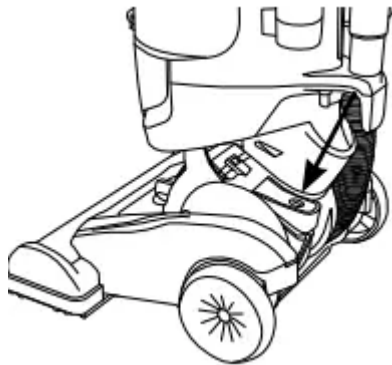

1 Step on the Power Pedal to turn ON/OFF.

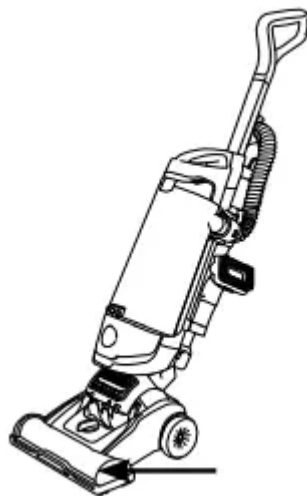

2 Step on the nozzle and lean the handle back.

USING THE HOSE AND TOOLS

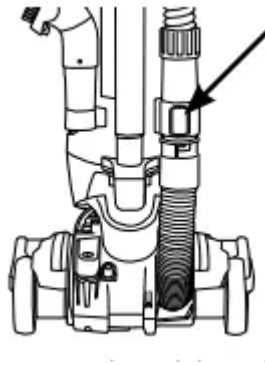

1 Make sure vacuum is upright and press the hose release button.

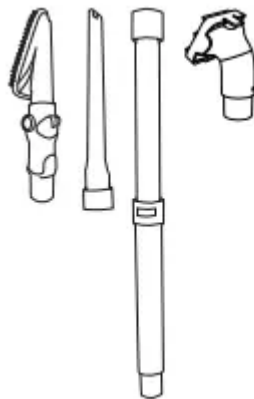

2 Remove hose and attach the desired accessory. The Telescopic Extension Wand can be added for additional reach.

MAINTENANCE

WARNING: To reduce the risk of personal injury, unplug before cleaning or servicing.

This product contains no serviceable parts. If appliance is not working as it should, has been dropped, damaged, left outdoors, or dropped into water, call customer service at 1.800.944.9200 prior to continuing use.

EMPTYING THE DIRT CUP

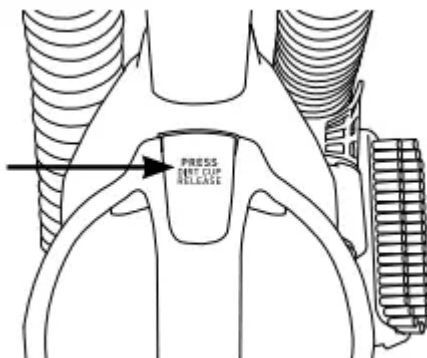

1 Press the dirt cup release button.

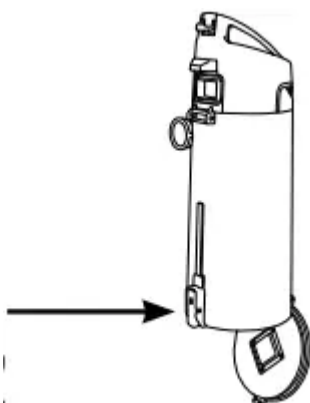

2 Empty over a trash can by pressing the trap door release.

CLEANING THE EXHAUST FILTER

PART #440014853

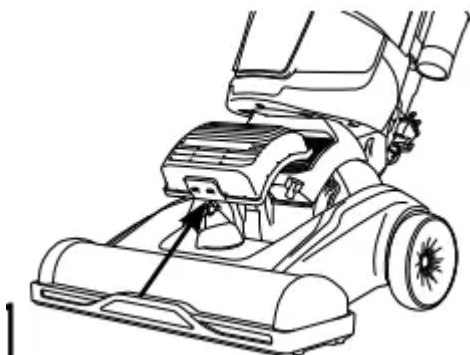

1 Tilt the vacuum back, then release the latch to remove the Exhaust Filter.

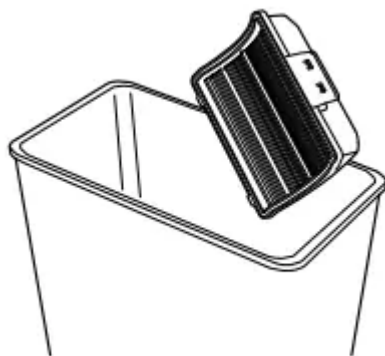

2 Tap the filter on trash can and wipe away remaining dust with a dry cloth. Place exhaust filter back onto the vacuum.

CLEANING THE RINSABLE FILTER

PART #AH44200

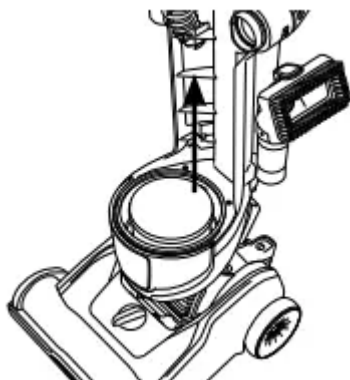

1 Remove the dirt cup, then remove the filter by pulling it up and out.

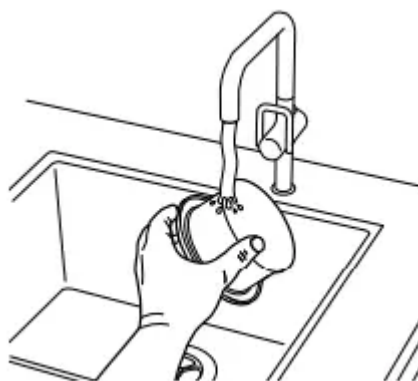

2 Rinse filter with water only until the filter is clean and the water runs through clear. Gently squeeze the filter to remove excess water.



Allow the filter to air dry for at least 24 hours.

IMPORTANT: The filter must be completely dry before replacing it. This may take between 24 and 48 hours. Check the inside of filter for dampness before replacing.

LUBRICATION: The motor is equipped with bearings which contain sufficient lubrication for their lifetime. The addition of lubricant could cause damage. Do not add lubricant to motor bearings.

CORD STORAGE: Wrap the power cord around the cord hooks for convenient storage. Attach the plug end to the cord.

CAUTION: To reduce the risk of injury from moving parts, unplug before servicing.

HOW TO REPLACE BELT AND CLEAN BRUSH ROLL

BRUSH ROLL PART #440014833

BELT PART #AH20080

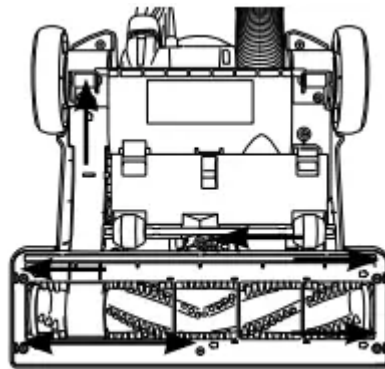

1 Remove the seven screws to remove the nozzle guard.

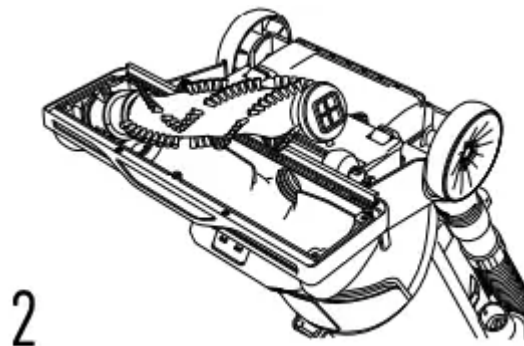

2 Pull the brush roll up and out from the vacuum belt.

3 Cut off tangled hair and wipe away any debris.

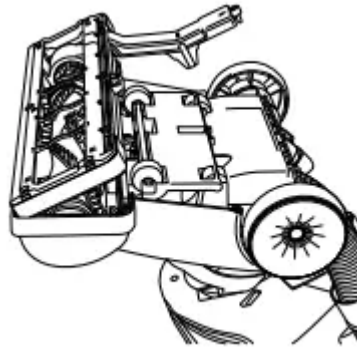

To replace the brush roll, loop the belt around the brush roll and push the roll back into place. Replace the nozzle guard and seven screws.

TIP: Rotate brush roll manually to ensure the belt is properly installed. Vacuum is equipped with an automatic brush roll shutoff in the event of overload or jam. Check for obstructions in the brush roll area and remove any obstructions. When obstructions are cleared, resume cleaning as normal.

WARNING: To reduce the risk of personal injury, unplug before cleaning or servicing.

REMOVING SYSTEM CLOGS

If you are experiencing a loss of suction, or you notice debris is spitting out of the nozzle, we recommend checking the nozzle, tube, hose and filters for any visible signs of blockage or built up debris. It is also recommended to rinse your Filter if there is visible built up dirt and dust on the filter. This should help improve performance on your vacuum.

THERMAL PROTECTION

A thermal protector has been designed into your cleaner to protect it from overheating. When the thermal protector activates the cleaner will stop running. If this happens proceed as follows:

1. Turn cleaner OFF and unplug it.
2. Empty the dirt cup
3. Inspect the nozzle inlet, hose connector, hose, dirt cup inlet, cyclonic filter rinsable filter and exhaust filter for any obstructions. Clear obstructions if present.
4. When cleaner is de-energized and motor cools for 30 minutes, the thermal protector will deactivate and cleaning may continue.

If the thermal protector continues to activate after following the above steps, your cleaner needs servicing.

TROUBLESHOOTING

WARNING: To reduce the risk of personal injury, unplug before cleaning or servicing.

FIND AVAILABLE REPLACEMENT PARTS AND ACCESSORIES AT HOOVER.COM IF APPLIANCE IS NOT WORKING AS IT SHOULD, HAS BEEN DROPPED, DAMAGED, LEFT OUTDOORS, OR DROPPED INTO WATER, CALL CUSTOMER SERVICE AT 1-800-944-9200 PRIOR TO CONTINUING USE. ALWAYS IDENTIFY YOUR CLEANER BY THE COMPLETE MODEL NUMBER. (THE MODEL NUMBER APPEARS ON THE BOTTOM OF THE CLEANER.)

My vacuum will not turn ON

1. Always be sure to plug it in firmly.
2. The Thermal Protector may have been activated - unplug your vacuum and let cool for 30 minutes. If this does not work, there may be no voltage in the wall plug.
3. Check the fuse or breaker in your home. If there is a blown fuse or tripped breaker, replace the fuse in your home or reset the breaker.

My vacuum is hard to push

1. Adjust the height of the nozzle with the knob on the foot of your vacuum.

My vacuum is losing suction and/or not picking up

1. Be sure to empty the dirt cup if it is full. Check that the dirt cup is properly assembled and installed onto the appliance.
2. You may have a clogged filter or a clog in the system. Refer to the Maintenance section in this manual for directions on removing clogs.
3. Your filter may be dirty. Pre-motor filters should be rinsed every 2-3 months. Refer to the Maintenance section for directions on how to clean filters.
4. Change the nozzle height, adjust setting for appropriate floor/carpet type.

My brush roll is not spinning

1. Unplug and remove any hair or other blockages around the brush roll.
2. Clean filters. Refer to the Maintenance section for directions on how to clean filters.
3. Resume normal operation.
4. Replace the belt.

Warning

This content is compiled from multiple sources and is provided for reference purposes only. It may not be complete or fully applicable to all situations. If you are unable to resolve your issue, please contact the product manufacturer or an authorized service provider for official support.

