

Guide to the appliance

Machine overview

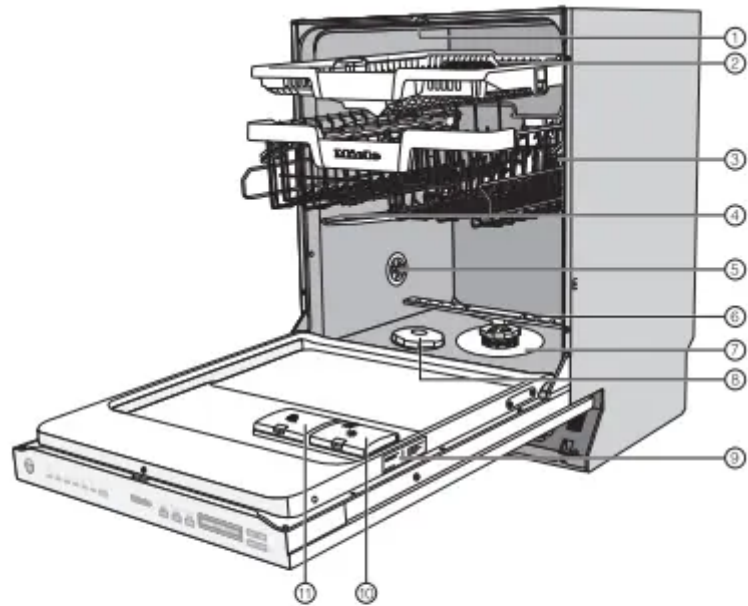

- | | |
|--|-------------------------|
| ① Top spray arm | ⑦ Filter combination |
| ② 3D MultiFlex Tray (depending on model) | ⑧ Salt reservoir |
| ③ Upper basket (depending on model) | ⑨ Data plate |
| ④ Middle spray arm | ⑩ Rinse aid reservoir |
| ⑤ Aeration valve | ⑪ Detergent compartment |
| ⑥ Bottom spray arm | |

Control panel



- | | |
|--|--|
| <p>① In-operation indicator light
For indicating an ongoing wash program when the door is closed.</p> <p>② Display
For further information, see "Display functions" under "Guide to the appliance".</p> <p>③ V/∧ buttons
For program selection.
For changing the values displayed.
For scrolling to other menu pages.</p> <p>④ OK button
To select menu options and values displayed.
To confirm messages.</p> <p>⑤ Back button
For navigating back to the previous menu or deleting values which have been set previously.</p> <p>⑥ ⌚ Timer button
For selecting a later program start.</p> | <p>⑦ Express button
For reducing the program cycle time.</p> <p>⑧ IntenseZone button
Increases cleaning performance in the lower basket.</p> <p>⑨ Program program selection button
For program selection.</p> <p>⑩ Program selection</p> <ul style="list-style-type: none"> ☑ Normal = Normal ☑ Pots = Pots & Pans ☑ Crystal = China & Crystal ☑ Quick = QuickIntenseWash ☑ Sani = SaniWash ☑ More = Additional programs/ settings <p>⑪ On/Off button
For turning the dishwasher on and off.</p> |
|--|--|

Display functions

The display is used to select or set the following:

- the program
- the Timer
- the Settings

The display can show the following:

- the program stage
- The estimated time left for the program to run
- Any relevant fault messages and information

To save energy, the dishwasher switches off after a few minutes if you do not press any buttons during this time.
Press the ⌚ button to switch the dishwasher back on.

The OK button is used to confirm a message or setting and also to move to the next menu or another level.

Under ☑ More, a scroll bar will appear in the right of the display. This offers further options. These options can be shown using the V/∧ buttons.

You can alter the dishwasher's controls to suit changing requirements in the "Settings" menu (see "Settings").

The option which is selected will have a check✓ next to it.

To exit a sub-menu again, press the Back button.

If you do not press any buttons for several seconds, the display will revert to the previous menu. You will then have to enter your settings again.

These operating instructions apply to several different dishwasher models of different heights. The specific dishwasher models are referred to as follows:
Standard = 31 11/16" (80.5 cm) high dishwashers (integrated)
and 33 1/4" (84.5 cm) high dishwashers (freestanding)
XXL = 33 1/4" (84.5 cm) high dishwashers (integrated).

Caring for the environment

Energy-saving dishwashing

This dishwasher is exceptionally economical in its use of water and electricity.

You can make the most of your machine by following these tips:

- Washing in a dishwasher generally uses less water and energy than washing by hand.
- There is no need to pre-rinse items under running water, and this unnecessarily increases water and energy consumption.
- Make full use of the basket capacity without overloading the dishwasher. This results in the most economical dishwashing in terms of energy and water consumption.
- Choose a program that best suits the degree of soiling and the type of dishes being washed (see "Program overview").
- Select the Normal program for energy-saving dishwashing. This program is the most efficient in terms of its combined energy and water consumption for cleaning dishware with a normal level of soiling.
- Follow the detergent manufacturer's recommendations on detergent dosage.
- When using powder or liquid detergent, you can use 1 /3 less detergent if baskets are only half full.
- You can connect the dishwasher to a hot-water supply. A hot water connection is particularly suitable with energy-saving water heating sources, such as solar energy with a circulation system. If the water is heated by electricity, we would recommend connection to cold water.

Operation

Turning on the dishwasher

- Turn on the water supply if it is turned off.
- Open the door.
- Make sure the spray arms can rotate freely.
- Press the  button. The program selected will appear in the display briefly and the indicator light for the program selected will come on. Then the display will show the estimated duration for the selected program.

Selecting a program

Choose your program according to the type of load and the degree of soiling. The different programs and their uses are described under Program overview.

- Use the Program button to select the program required.

The indicator light next to the program selected will come on. Additional programs can be selected under  More.

- Use the Program button to select the  More option.

The first of the additional programs will appear in the display.

- Use the   buttons in the display to select the program you want.







You can now select program options (see “Options”).

If any program options are selected, the appropriate indicator lights will also light up.

Display of program duration

The estimated duration of the selected program appears on the display before the program begins. If the door is opened during the program, the time left until the end of the program is displayed.

Each program phase is indicated by a symbol:

-  Pre-rinse/Soak
-  Main wash
-  Interim rinse
-  Final rinse
-  Drying
-  Finish

The displayed duration may vary for the same program. It is influenced by, for example, the temperature of the incoming water, the reactivation cycle of the water softener, the detergent type, and the number of dishes and how soiled they are.

When a program is selected for the first time, the display will show the average program duration for a cold water connection.

The program durations shown under “Program overview” refer to standard test loads and temperatures.

Each time a program is run, the control module calculates the program duration required depending on the temperature of the water taken into the dishwasher and the amount of dishes.

Starting a program

- Start the program by closing the door within 4 seconds of the last press of a button.

If necessary, confirm the previously displayed message with OK.

The in-operation indicator light comes on to show that a program has been started.

If you do not close the door within 4 seconds, the message Continue with OK will appear in the display. The program cannot be started until you confirm the message by pressing the OK button and close the door within 4 seconds.

During a program sequence, you can use OK to display the name of the program that is currently running when the door is open.

WARNING: Risk of scalding due to hot water. During operation, water in the dishwasher may be very hot. During operation, only open the door with extreme caution.

End of program

At the end of a program, the in-operation indicator light will be flashing slowly with the door shut. The audible signal may also be sounding.

The in-operation indicator light will go out 10 minutes after the end of the program if the door is closed.

The program has ended when the display shows the message  Ready.

In some programs, if the AutoOpen function is activated, the door will automatically open slightly (see “AutoOpen” under “Settings”). This improves the drying process.

The drying fan may continue to run for a few minutes at the end of the program.

WARNING: Risk of damage due to steam. Steam from the dishwasher could damage the edges of delicate countertops when you open the door at the end of the program if the fan is no longer running. If you have deactivated the automatic door opening function (see “AutoOpen” under “Settings”), but would still like to open the door at the end of the program, then make sure that you open the door fully.

Energy management

To save energy, the dishwasher will switch off automatically 10 minutes after the last time a button is pressed or after the end of a program.

You can turn the dishwasher back on again with the 1 button.



The dishwasher will not turn itself off while a program is running or if there is a fault.

Turning off the dishwasher

- Open the door.
- The dishwasher can be turned off at any time using the  button.
- Confirm the query Turn appliance off with OK.

Turning the dishwasher off during a program stops the program.

You can also do this to stop an ongoing timer.

- If you have pressed the  button, but do not wish to cancel the program, use the  button to select the Do not turn off option on the display and confirm with OK.
- Risk of damage from leaking water. Leaking water can cause damage. If the dishwasher is not going to be used for a longer period of time, e.g., during vacations, the water supply should be turned off.

Unloading the dishwasher

Dishes tend to break and chip more easily when they are hot. Allow the dishes to cool until they are comfortable enough to handle before unloading them.

The dishes will cool much faster if you open the door when the program has ended.

- First unload the lower basket, then the upper basket, and finally the 3D MultiFlex Tray (if present).

This will prevent water drops from the upper basket and 3D MultiFlex Tray from falling onto the dishes in the lower basket.

Interrupting a program

A program will be interrupted as soon as the door is opened. After 4 seconds, the indicator light of the selected program and the time display will flash.

- Press the program selection button  and close the door within 4 seconds.

The program will continue from the point at which it was interrupted.

Risk of scalding due to hot water.

During operation, water in the dishwasher may be very hot.



During operation, only open the door with extreme caution.

Canceling or changing a program

If a program is canceled, important program stages may be missed.

A program should only be canceled in the first few minutes.

If a program has already started and you wish to cancel it, proceed as follows:

- Open the door.
- Turn the dishwasher off with  button.
- Confirm the query Turn appliance off with OK. If you would like to select another program:
- Turn the dishwasher on again with the  button.
- If you have dispensed detergent manually, check whether the detergent compartment is still closed. If the lid is already open, fill it with detergent again and close the lid.
- Select the program you want, and then start it by shutting the door.

The in-operation indicator light comes on to show that a program has been started.

Cleaning and care

Check the condition of your dishwasher regularly (approx. every 4– 6 months). This helps to avoid faults and problems.

WARNING: Damage due to unsuitable cleaning agents. All surfaces are susceptible to scratching. Contact with unsuitable cleaning agents can alter or discolor all surfaces. Only use cleaning agents formulated for use on the relevant surfaces.

Cleaning the wash cabinet

The wash cabinet is largely self-cleaning, provided that the correct amount of detergent is always used.

If, despite this, limescale or grease deposits build up in the cabinet, these can be removed with a proprietary dishwasher cleaner (available from the Miele Customer Service or Miele's online store). Follow the dosage recommended by the manufacturer on the packaging.

The frequent use of low-temperature wash programs increases the risk of contamination and odors inside the wash cabinet. Run the Pots & Pans program once per month to clean the wash cabinet and prevent odors from developing.

- Clean the filters in the wash cabinet regularly.

Cleaning the door and the door seal

The door seal and the sides of the dishwasher door are not accessed and cleaned by the spray arm jets. As a result, mold can develop here.

- Wipe the door seals regularly with a damp cloth to remove food deposits.
- Wipe off any food or drink residues that may have dripped onto the sides of the dishwasher door before closing it.

Cleaning the control panel

- The control panel should only be wiped with a damp cloth.

Cleaning the reflector panel

The reflector panel for the in-operation indicator light is situated on the cover sheeting underneath the countertop.

- The reflector panel should only be cleaned with a damp cloth if necessary.

Cleaning the front of the machine

Damage due to soiling. Soiling that is left too long might become impossible to remove and could cause the external surfaces to alter or discolor.

It is therefore best to remove any soiling immediately.

- Clean the appliance front with a clean soft sponge and a solution of warm water and liquid dish soap. After cleaning, wipe the surfaces dry using a soft cloth.

A clean, damp microfiber cloth without detergent can also be used.

To avoid damaging the external surfaces, do not use the following:

- cleaning agents containing soda, ammonia, acids, or chloride
- cleaning agents containing limescale remover
- abrasive cleaning agents, such as scouring powder, scouring liquid, or pumice stones
- cleaning agents containing solvents
- stainless-steel cleaning agents
- dishwasher cleaner
- oven cleaner
- glass cleaner
- hard, abrasive brushes or sponges, e.g., pot scourers, brushes, or sponges which have been previously used with abrasive cleaning agents
- eraser sponges

- sharp metal scrapers
- steel wool
- steam cleaners

Cleaning the spray arms

Particles of food can get stuck in the spray arm jets and bearings. The spray arms should therefore be inspected regularly (approx. every 2–4 months).

Damage due to soiling entering the circulation system.

Without filters, soiling can enter the circulation system and cause a blockage.

Do not run a wash program without the lower spray arm or the filters. When cleaning the filters and spray arms, make sure that coarse soiling cannot get into the circulation system.

- Turn off the dishwasher

Removing the upper and middle spray arms

- Take out the 3D MultiFlex Tray (if your dishwasher is fitted with one).
- Push the upper spray arm upwards to engage the inner ratchet. Then unscrew the spray

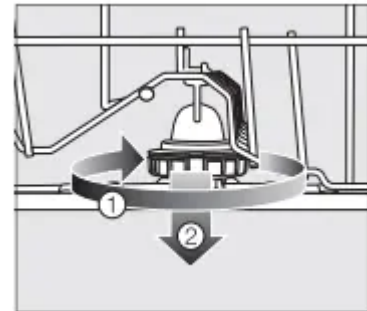

arm by rotating the screw thread counterclockwise.

- Rotate the screw thread of the middle spray arm clockwise ^① (see diagram) and remove the spray arm ^②.

Removing the lower spray arm

-

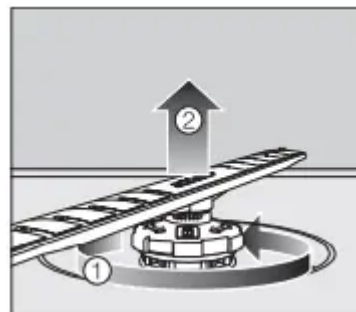

Remove the lower basket.

- Rotate the screw thread of the lower spray arm counterclockwise ^① and pull the spray arm upwards to remove ^②.

Cleaning the spray arms

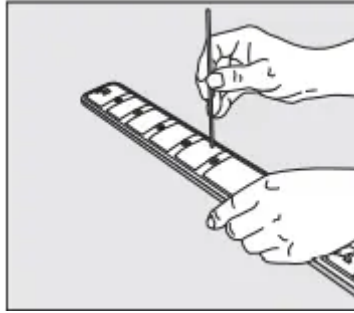

- Use a pointed object to push food particles that are stuck in the spray arm jets into the spray arm.
- Rinse the spray arm thoroughly under running water.

Refitting the spray arms

- Refit the upper and middle spray arms.
- Refit the lower spray arm and ensure that the filter combination lies flat in the base of the

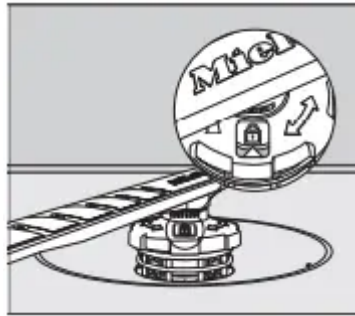

wash cabinet.

- Rotate the screw thread of the lower spray arm clockwise until the arrow in the viewing window points to the lock symbol .
- Make sure the spray arms can rotate freely.

Damage due to soiling entering the circulation system.

The lower spray arm is used to secure the filter combination. Without filters, coarse soiling can enter the circulation system and cause a blockage.

Do not run a wash program without the lower spray arm or without the filters.

Checking the filters in the wash cabinet

The filter combination in the base of the wash cabinet retains coarse soil from the suds solution. This prevents soiling getting into the circulation system and re-entering the wash cabinet through the spray arms.

Damage due to soiling entering the circulation system.

Without filters, soiling can enter the circulation system and cause a blockage.

Do not run a wash program without the lower spray arm or without the filters.

When cleaning the filters and spray arms, make sure that coarse soiling cannot get into the circulation system. The filters can become blocked by soiling that collects over time. The level of soiling and time it takes before the filters need cleaning will vary depending on use.

The message Check filters will appear in the display after every 50 program sequences.

- Check the filter combination.
- Clean if necessary.
- Then confirm the message with OK.

Cleaning the filters

- Turn off the dishwasher.
- Remove the lower spray arm (see “Cleaning the spray arms” under “Cleaning and care”).
- Before removing the filter combination, remove any coarse soiling to prevent it from entering the circulation system.

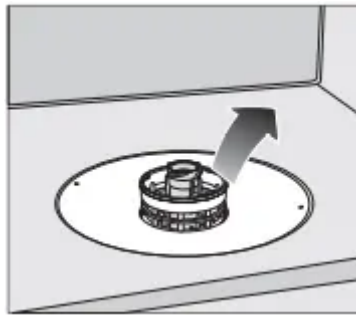

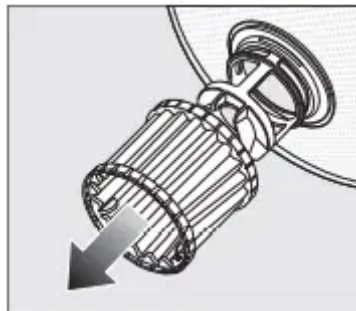

- Remove the filter combination.

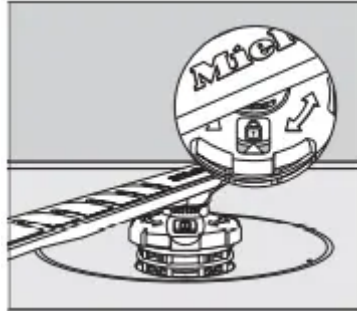

- In order to clean the inside of the filter, pull the microfilter on the plastic ring downwards and away from the filter combination.
- Rinse all of the filters under running water. If necessary, use a soft cleaning brush to remove soiling.
- Insert the microfilter back into the filter combination.
- Reinstall the filter combination so that it lies flat in the base of the wash cabinet.

- Refit the lower spray arm to the filter combination using the screw thread.



- Rotate the screw thread clockwise until the arrow in the viewing window points to the lock symbol 
- Damage due to soiling entering the circulation system.
- The lower spray arm is used to secure the filter combination. Without filters, coarse soiling can enter the circulation system and cause a blockage.
- Do not run a wash program without the lower spray arm or without the filters.

Cleaning the drain pump

If water remains in the wash cabinet after the end of a program, the water has not been pumped away. The drain pump may be blocked by foreign objects. These foreign objects are easy to remove.

- Disconnect the dishwasher from the power supply. To do this, turn off at the electrical socket and withdraw the plug.
- Take the filter combination out of the wash cabinet (see “Cleaning the filters” under “Cleaning and care”).
- Scoop the water out of the wash cabinet using a suitable small container or utensil.

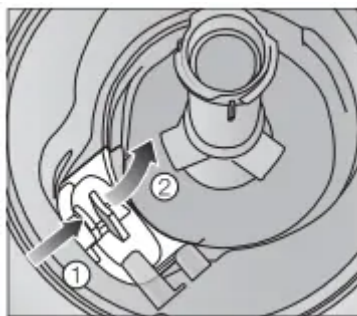

- Press the catch of the drain pump cover inwards ^①.
- Tip the cover inwards until it is released ^②.

- Rinse the cover thoroughly under running water and remove all foreign objects.

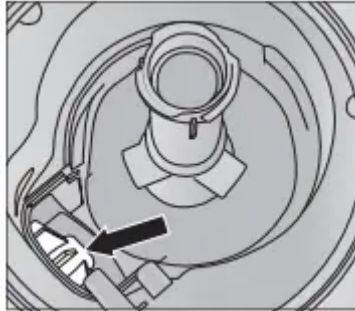

The drain pump (see arrow) is underneath the cover.

Risk of injury from glass splinters.

It is especially difficult to see glass splinters in the drain pump.

Take care when cleaning the drain pump.

- Carefully remove all foreign objects from the drain pump. Check the drain pump impeller by manually turning it. You will feel a little resistance when you turn the impeller.
- Refit the cover by placing it down vertically from above. Ensure that the catch engages correctly.

Damage due to incorrect cleaning.

The components are delicate and can be damaged during cleaning.

Take care when cleaning the drain pump.

Frequently Asked Questions

With the help of the following guide minor faults in the performance of the machine, some of which may result from incorrect operation, can be remedied without contacting the Service Department.

This guide may help you to find the reason for the fault, and how to correct it.

This section only lists faults that you can remedy yourself. All other faults are shown in  Fault FXX.

Technical faults

The dishwasher does not start.

The dishwasher is not plugged in.

- Raise the door upward until the catch engages.

The dishwasher is not plugged in.

- Insert the plug.

The circuit breaker has tripped.

- Reset the breaker (see data tag for the correct fuse rating).

- If the breaker trips again, contact Miele Customer Service.

The dishwasher is not turned on.

- Turn the dishwasher on with the  button.

The dishwasher stops during a program.

The circuit breaker has tripped.

- Reset the circuit breaker (see data plate for the correct fuse rating).
- If the circuit breaker trips again, contact Miele Customer Service.

Fault messages

The in-operation indicator light is flashing quickly. The alarm tone is sounding. One of the following faults appears in the display:

Before remedying the fault:

- Turn off the dishwasher.

Fault FXX

There may be a technical fault.

- Turn the dishwasher back on after a few seconds.
- Select the desired program.
- Close the door.

If the fault message appears again, there is a technical fault.

- Turn off the dishwasher.
- Turn off the water supply.
- Contact Miele Customer Service.

Waterproof

The Waterproof system has reacted.

- Turn off the dishwasher.
- Turn off the water supply.
- Contact Miele Customer Service.

Fault F78

Circulation pump fault.

- Turn off the dishwasher.
- Turn the dishwasher back on.
- Select the desired program.

- Close the door.

If the fault message appears again, there is a technical fault.

- Turn off the dishwasher.
- Turn off the water supply.
- Contact Miele Customer Service

Door release

The in-operation indicator light is flashing quickly. The alarm tone is sounding. The following fault is indicated via the display:

Before remedying the fault:

- Turn off the dishwasher

Fault F33

The door does not open automatically.

There may be a technical fault.

- Open the door manually (see “Opening the door” under “Before using for the first time”) and turn the dishwasher back on again.
- If the same fault message appears again, contact Miele Customer Service.

The door locking pins do not retract after the door is opened.

There may be a technical fault.

- Turn the dishwasher back on.
- If the same fault message appears again, contact Miele Customer Service.

Water intake fault

The in-operation indicator light is flashing quickly. The alarm tone is sounding. One of the following messages appears in the display:

Open water supply

The water supply is turned off

- Open the water supply valve all the way

Intake

Before remedying the fault:

- Turn off the dishwasher

There is a problem with the water intake.

- Turn on the water supply fully and start the program again.

- Clean the filter in the water intake (see “Cleaning the filter in the water intake” under “Cleaning and care”).
- The water-connection pressure is lower than 7.25 psi (50 kPa). Seek professional advice.
- The on-site connection for the water drainage may be too low and you will need to vent the water drainage (see “Water drainage” under “Installation”)

Fault F18

A technical fault has occurred.

- Turn off the dishwasher.
- Turn off the water supply.
- Contact Miele Customer Service.

Water drainage fault

The in-operation indicator light is flashing quickly. The alarm tone is sounding. The following message appears on the display:  Drain.

Before remedying the fault:

- Turn off the dishwasher

Water drainage fault.

There might be water in the wash cabinet.

- Clean the filter combination (see “Cleaning the filters” under “Cleaning and care”).
- Clean the drain pump (see “Cleaning the drain pump” under “Cleaning and care”).
- Remove any kink or loop in the drain hose.

General dishwasher problems

The in-operation indicator light is flashing quickly. The alarm tone is sounding. The indicator light of the selected program and the time display will flash. The dishwasher does not start or the delay start time stops running.

The safe mode of the dishwasher was activated. This takes place in the following instances:

- If you do not close the door within 4 seconds of the last press of a button at program start.
- If the door is open for longer than 4 seconds during a program or within the delay-start time.
- Press the program selection button and close the door within 4 seconds.

The indicator lights and the display are dark.

The dishwasher has turned off automatically to save energy.

- Turn the dishwasher on again with the  button.

Detergent residue is left in the detergent compartment at the end of a program.

The detergent compartment was still damp when detergent was added.

- Only add the detergent when the detergent compartment is dry.

The detergent compartment lid cannot be closed.

Residual detergent is blocking the catch.

- Remove the residual detergent.

At the end of a program there is a film of moisture on the inside of the door and possibly on the interior cabinet walls.

This is part of the normal function of the drying system. The moisture will dissipate after a short time.

Water remains in the wash cabinet at the end of a program.

Before remedying the fault:

- Turn off the dishwasher.

The filter combination in the wash cabinet is clogged.

- Clean the filter combination (see “Cleaning the filters” under “Cleaning and care”).

The drain pump is blocked.

- Clean the drain pump (see “Cleaning the drain pump” under “Cleaning and care”).

The drain hose is kinked.

- Remove any kinks from the drain hose.

Noises

There is a knocking noise in the wash cabinet.

A spray arm is knocking against a wash item.

- Carefully open the door and rearrange the wash items that are obstructing the spray arm.

There is a rattling noise in the wash cabinet.

Wash items are not secure in the wash cabinet.

- Carefully open the door and rearrange the wash items so that they sit securely.

There is a foreign object (e.g., glass shard) in the drain pump.

- Remove the foreign object from the drain pump (see “Cleaning the drain pump” under “Cleaning and care”)

Knocking noise in the water pipes

This may be caused by the on-site installation or the cross-section of the piping.

- However, this will not affect the functioning of the dishwasher in any way. If in doubt, contact a suitably qualified plumber.

Poor cleaning results

The dishes are not clean.

The dishes were not loaded correctly.

- See notes under “Loading the dishwasher”.

The program was not powerful enough.

- Select a more powerful program (see “Program overview”).

Not enough detergent was dispensed during manual detergent dispensing.

- Use more detergent, or change the brand you are using. Items are blocking the path of the spray arms.
- Carry out a rotation check and if needed rearrange the items so that the spray arms can rotate freely.

The filter combination in the wash cabinet is not clean or was incorrectly fitted. This may have caused the spray arm jets to become blocked.

- Clean and/or fit the filter combination correctly.
- Clean the spray arm jets if necessary (see “Cleaning the spray arms” under “Cleaning and care”).

There are smears on glassware and cutlery. There is a bluish sheen on the surface of glassware. The film can be wiped off.

The rinse aid dosage is set too high.

- Reduce the dosage (see “Rinse aid” under “Settings”)

Dishes are not dry or cutlery and glasses are spotty.

The rinse aid dosage is set too low or the rinse aid reservoir is empty.

- Replenish the reservoir, increase the dosage, or change the brand of rinse aid (see “Rinse aid” under “Before using for the first time”).

Dishes were taken out of the wash cabinet too soon.

- Leave dishes in longer (see “Operation” under “Unloading the dishwasher”).

The duration of the drying phase for the selected program is not sufficient for the dishes.

- Select the Extra dry function (see “Extra dry” under “Settings”).

You have used combination products that have insufficient drying performance.

- Switch to another detergent, or replenish the rinse aid (see “Rinse aid” under “Before using for the first time”).

Glassware has a brown or blue tinge. The film cannot be wiped off.

Ingredients from the detergent have formed a deposit.

- Switch to another detergent straight away.

Glassware is dull and discolored. The film cannot be wiped off.

The glassware is not dishwasher-safe. The surface has altered.

- No remedy.

Purchase glassware which is dishwasher-safe.

Tea or lipstick stains have not been completely removed.

The wash temperature of the selected program was too low.

- Select a program with a higher wash temperature.

The bleaching effect of the detergent is too low.

- Switch to another detergent.

Plastic parts are discolored.

Natural dyes, e.g., from carrots, tomatoes, or ketchup may be the cause. The amount of detergent used or its bleaching effect was not sufficient to deal with natural dyes.

- Use more detergent (see “Detergent”). Parts that are already discolored will not revert to their original color.

White residue is visible on the dishes. Clouding has occurred on glassware and cutlery. The film can be wiped off.

The rinse aid dosage is set too low.

- Increase the dosage (see “Rinse aid” under “Settings”).

The salt reservoir is empty.

- Fill the salt reservoir (see “Reactivation salt” under “Before using for the first time”).

The salt reservoir cap has not been screwed on correctly.

- Replace it, making sure that it screws back on correctly.

Unsuitable combination detergents were used.

- Switch to another detergent. If using tabs or powder detergent, do not choose combination products and ensure you refill the reactivation salt and rinse aid.

The water softener is programmed to too low a water hardness level.

- Program the water softener to a higher water hardness level (see “Water hardness” under “Settings”)

There are rust stains on the cutlery.

The affected items are not corrosion resistant.

- No remedy.

Purchase cutlery which is dishwasher-proof.

A program was not run after reactivation salt was added. Traces of salt have got into the normal wash cycle.

- Always run the ☺ QuickIntenseWash program with the ☺ Express program option selected and without any dishes in the dishwasher after adding reactivation salt

The salt reservoir cap has not been screwed on correctly.

- Replace it, making sure that it screws back on correctly

Installation

Water intake

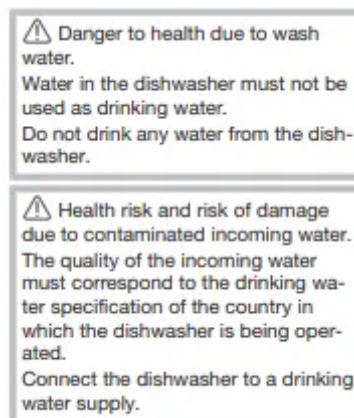

The dishwasher may be connected to cold or hot water (up to max. 150°F/65°C) supplies.

We recommend connecting to a cold water supply to reduce energy consumption.

If energy-saving water heating sources, such as solar energy circulation systems, are used, we recommend connecting to the hot water. This saves both time and electrical energy costs.

Hot water is used in all programs.

The EnergySaver program (if available) requires a hot water connection of between a minimum of 115°F/45°C and a maximum of 150°F/65°C (intake temperature).

The higher the water intake temperature, the better the cleaning and drying results. The intake hose is approx. 5 ft (1.5 m) long. A 5 ft (1.5 m) long, flexible metal extension hose (tested to 2,030 psi/14,000 kPa) is available as an optional accessory from Miele specialist retailers or Miele Customer Service.

A faucet with a 3/8" GHT connection must be provided on site. If this type of faucet is not available, only a qualified installer may connect the dishwasher to the domestic water supply.

A back-flow preventer is not required by the manufacture, but may be required by local code regulations.

The water-connection pressure needs to be between 7.25 and 145 psi (50 and 1,000 kPa). If the water-connection pressure is too high, a pressure reducing valve must be fitted.

 Risk of damage from leaking water.
The connection point is subject to domestic water pressure. Water leaking from it can cause damage.
You should therefore open the water supply slowly and check for leaks. Correct the position of the washer and screw thread if appropriate.

 Risk of damage due to excessive pressure.
A brief increase in the water pressure can damage components of the dishwasher.
This dishwasher must only be operated when it is connected to a fully vented plumbing system.

 Risk of damage from leaking water.
The intake hose is under water pressure.
The intake hose must not be shortened or damaged in any way.

 Do not sit the dishwasher on the hose. The hose needs to be free of kinks and able to move freely after installation. Do not place hose or power cord next to a heat source e.g., hot water pipes. Do not expose hose or power cord to corrosive substances (e.g., chloride). Damage of hose or power cord could cause electrical shock or water damage.

Water drainage

The appliance drainage system has a non-return valve, which prevents dirty water from flowing back into the dishwasher via the drain hose.

The dishwasher is supplied with approx. 5 ft (1.5 m) of flexible drain hose with an internal diameter of 7/8" (22 mm).

The hose can be extended using a connection piece to attach a further length of hose. The drainage length must not be longer than 13 ft (4 m) and the delivery head no higher than 3 ft (1 m).

If the hose is to be directly connected to the drainage outlet on site, use the supplied hose clip (see the installation diagram).

The hose can be directed to the left or the right of the appliance.

The on-site connector for the drain hose can be used for various hose diameters. If the connector extends too far into the drain hose, it must be shortened. Otherwise, the drain hose can become clogged.

Only use a Miele approved connection piece when extending the drain line. Only use a Miele extension drain hose.

The drain hose must not be shortened.

Lay the drain hose so that it does not kink and is not being subjected to pressure or tugged.

 Risk of damage from leaking water.
Leaking water can cause damage.
After servicing the appliance, ensure that the drain does not leak.

Venting the water drainage

If the on-site drainage connection is situated lower than the guide path for the lower basket rollers in the open door, the drainage system must be vented. Otherwise, a siphoning effect during a program can cause the appliance to empty itself of water.

- Open the dishwasher door fully.

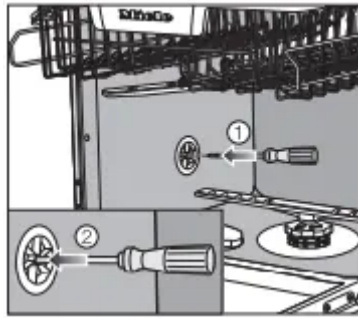

- Remove the lower basket.
- Insert a screwdriver into the middle opening of the vent valve in the left wash cabinet wall **①**.
- Press the screwdriver further into the opening and push it through the membrane behind **②**.
- The vent opening for the water drain is now open.

Electrical connection

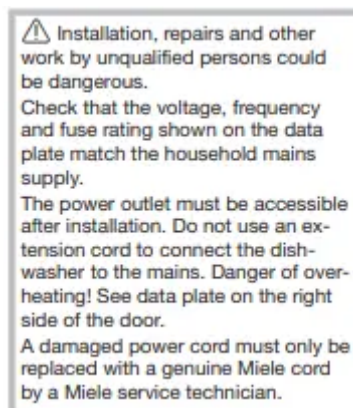

Grounding instructions

THIS APPLIANCE MUST BE GROUNDED

In the event of a malfunction or breakdown, grounding will reduce the risk of electric shock by providing a path of least resistance for the electrical current. This appliance is equipped with a cord having an equipment grounding conductor and a grounding plug. The plug must be plugged into an appropriate outlet that is installed and grounded in accordance with all local codes and ordinances.

 Improper connection of the equipment grounding conductor can result in electric shock.
Do not modify the plug provided with the appliance; if it will not fit the outlet, have a proper outlet installed by a qualified electrician.
If there is any question concerning the proper electrical connection or grounding of this appliance to the powersupply, please consult a licensed electrician or call Miele's Customer Service Department:
USA: 1-888-99-MIELE(64353)
CDN: 1-800-565-6435

Specifications

The dishwasher comes equipped with a 4 ft (1.2 m) power cord (measured from the rear of the dishwasher) with a molded plug for connection to 120 V, 60 Hz, 15 A grounded receptacle.

Hardwired electrical connection

It is possible to hardwire this appliance to an existing power cable.

 Prior to making a hardwire connection to the terminal, remove the powercord. Otherwise there will be a risk of electric shock from the attached plug.

GROUNDING INSTRUCTIONS

THIS APPLIANCE MUST BE GROUNDED.

This appliance must be connected to a grounded metal, permanent wiring system, or an equipment-grounding conductor must be run with the circuit conductors and connected to the equipment-grounding terminal or lead on the appliance.

 Prior to making a hardwire connection to the terminal, remove the powercord. Otherwise there will be a risk of electric shock from the attached plug.

An existing flexible supply cord or cable shall have a minimum thickness of AWG 14. 120 V, 60 Hz, 15 A fuse rating
Black wire (live): connect to L
White wire (neutral): connect to N
Green wire (ground): connect to 

⚠ After attaching the permanent power supply cord, check that all wires are correctly and securely placed in the connector and the strain relief is tightened.

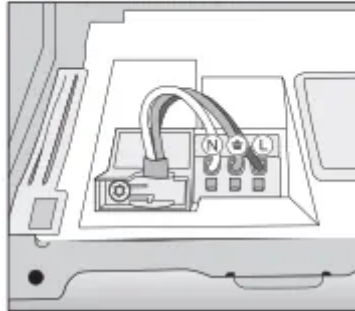

Warning

This content is compiled from multiple sources and is provided for reference purposes only. It may not be complete or fully applicable to all situations. If you are unable to resolve your issue, please contact the product manufacturer or an authorized service provider for official support.