

USER MANUAL MICROWAVE OVENS

Specifications

Model:	EM036AB14
Rated Voltage:	120V~ 60Hz
Rated Input Power(Microwave):	1450W
Rated Output Power(Microwave):	1000W
Oven Capacity:	1.4 Cu.ft
Turntable Diameter:	12.4 inch
External Dimensions:	20.4×16.9×12.4 inch (519×430×315 mm)
Net Weight:	33.3Lbs (15.12 kg)

Names of Oven Parts and Accessories

Remove the oven and all materials from the carton and oven cavity.

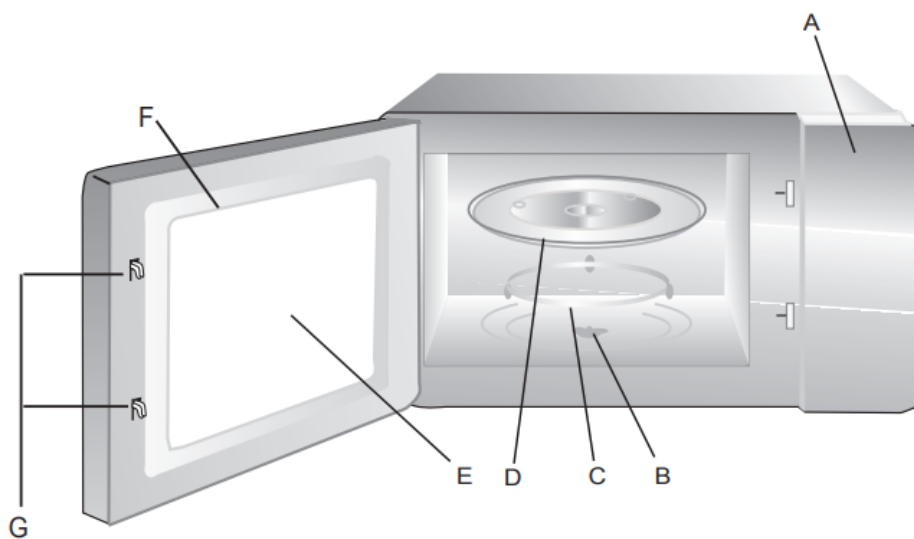

- A) Control panel
- B) Turntable shaft
- C) Turntable ring assembly
- D) Glass tray
- E) Observation window
- F) Door assembly
- G) Safety interlock system

OPERATION

Control Panel and Features

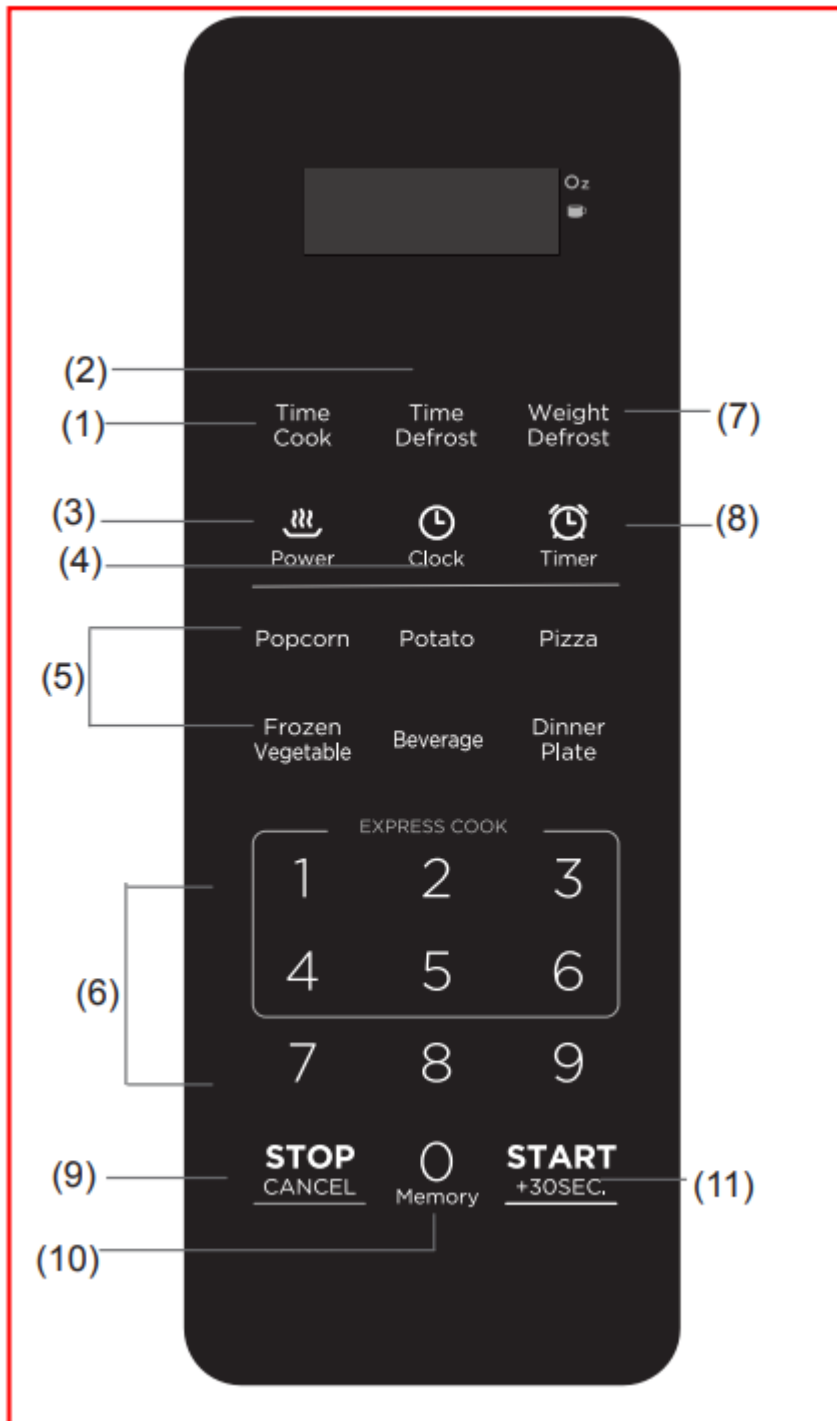

(1) Time Cook	(7) Weight Defrost
(2) Time Defrost	(8) Kitchen Timer function
(3) Power	(9) Stop/Cancel: clears all previous setting pressed before cooking starts. During cooking: press once to stop oven; twice to stop and clear all entries.
(4) Clock	(10) Memory function
(5) Auto menu: Popcorn, Potato, Pizza, Frozen vegetable, Beverage, Dinner plate	(11) Start/+30Sec.
(6) Number Buttons:0-9	

Power Level

11 power levels are available.

Level	10	9	8	7	6	5	4	3	2	1	0
Power	100%	90%	80%	70%	60%	50%	40%	30%	20%	10%	0%
Display	PL10	PL9	PL8	PL7	PL6	PL5	PL4	PL3	PL2	PL1	PL0

Clock Setting

(1) Press " CLOCK ", "00:00" will display.



(2) Press the number keys and enter the current time. For example, time is 10:12 now, please press "1,0,1,2" in turn.



(3) Press " CLOCK " to finish clock setting. ":" will flash and the clock will be lighted.

(4) If the numbers input are not within the range of 1:00--12:59, the setting will be invalid until valid numbers are input.

Note

(1) In the process of clock setting, if the " STOP/CANCEL " button is pressed or if there is no operation within 1 minute, the oven will go back to the former setting automatically

(2) If the clock need to be reset, please repeat step 1 to step 3.

Kitchen Timer

(1) Press "TIMER ", LED will display 00:00, the first hour figure flash.



(2) Press the number keys and enter the timer time. (The maximum cooking time is 99 minutes and 99 seconds.)

(3) Press " START/+30SEC. " to confirm setting.

(4) When the timer time arrives, the buzzer will ring 5 times.

If the clock is set (12-hour system), LED will display the current time.

Microwave cook

(1) Press "TIME COOK" once, LED will display "00:00".



(2) Press number keys to input the cooking time; the maximum cooking time is 99 minutes and 99 seconds.

(3) Press " POWER " once, LED will display "PL10". The default power is 100% power. Now you can press number keys to adjust the power level.

(4) Press " START/+30SEC." to start cooking.

Example: to cook the food with 50% microwave power for 15 minutes.

a. Press "TIME COOK" once."00:00" displays.

b.Press "1", "5", "0", "0" in order.



c.Press "POWER"once,then press "5" to select 50% microwave power.

d.Press "START/+30SEC." to start cooking.

Speedy Cooking

(1) In waiting state, instant cooking at 100% power level can be started by select a cooking time from 1 to 6 minutes by pressing number pads1 to 6. Press " START/+30SEC." to increase the cooking time; the maximum cooking time is 99 minutes and 99 seconds.

(2) In waiting state, instant cooking at 100% power level with 30 seconds' cooking time can be started by pressing " START/+30SEC ". Each press on the same button will increase cooking time by 30 seconds. The maximum cooking time is 99 minutes and 99 seconds.

Weight Defrost Function

(1) Press " WEIGHT DEFROST ", LED will display "dEF1".



(2) Press numerical buttons to input weight to be defrosted. Input the weight ranged between 4~100 Oz.



(3) If the weight input is not within 4~100 Oz, the input will be invalid.

(4) Press " START/+30SEC. " to start defrosting and the cooking time remained will be displayed.

Time Defrost Function

(1) Press " TIME DEFROST ", LED will display "dEF2".



(2) Press number pads to input defrosting time. The effective time range is 00:01~99:99.

(3) The default microwave power is power level 3. If you want to change the power level, press " POWER " once, and the LED will display "PL 3", then press the number pad of the power level you wanted.

(4) Press " START/+30SEC. " to start defrosting. The remained cooking time will be displayed.

MEMORY FUNCTION

(1) Press "0/MEMORY" to choose memory 1-3 procedure. The LED will display 1,2,3.

(2) If the procedure has been set, press " START/ +30 SEC." to use it. If not, continue to set the procedure. Only one or two stages can be set

(3) After finishing the setting, press "START/ +30 SEC." once to save the procedure. If press " START/ +30 SEC." again, it will start cooking.

Example: to set the following procedure as the second memory, that is memory 2. to cook the food with 80% microwave power for 3 minutes and 20 seconds.

The steps are as follow:

- a. In waiting state, press "0/MEMORY" twice, stop pressing until the screen displays "2".
- b. Press "TIME COOK" once, then press "3", "2", "0" in order.
- c. Press "POWER" once, "PL10" display, then press "8" and "PL8" displays.
- d. Press "START/ +30 SEC." to save the setting. Buzzer sounds once and the LED will display "2". If you press "START/+30SEC." again, the procedure will be saved as the memory 2 and operated.
- e. If the electricity is not cut off, the procedure will be saved all the time. If it is, the procedure need to reset.
- f. If you want to run the saved procedure, in waiting state, press "0/MEMORY" twice, screen displays "2", then press "START/+30SEC." to run.

MULTI STAGE COOKING

At most 2 stages can be set for cooking. In multi-stage cooking, if one stage is defrosting, then defrosting shall be placed at the first stage automatically.

Note: Auto cooking cannot work in the multi-stage cooking.

Example: if you want to cook with 80% microwave power for 5 minutes + 60% microwave power for 10 minutes. The cooking steps are as following:

- (1) Press "TIME COOK" once, then press "5", "0", "0" to set the cooking time;
- (2) Press "POWER" once, then press "8" to select 80% microwave power.
- (3) Press "TIME COOK" once, then press "1", "0", "0", "0" to set the cooking time;
- (4) Press "POWER" once, then press "6" to select 60% microwave power.
- (5) Press "START/ +30 SEC." to start cooking.

INQUIRING FUNCTION

- (1) In cooking state, press " CLOCK ", the LED will display clock for three seconds.
- (2) In the microwave cooking state, press " POWER " to inquire microwave power level, and the current microwave power will be displayed. After three seconds, the oven will turn back to the previous state. In multi-stage state, the inquiring way can be done by the same way as above.

LOCK FUNCTION FOR CHILDREN

Lock: In waiting state, press " STOP/CANCEL " for 3 seconds, there will be a long "beep" denoting the entering into the children-lock state; meanwhile, LED will display "

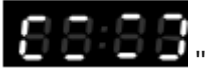

Lock quitting: In locked state, press " STOP/CANCEL " for 3 seconds, there will be a long "beep" denoting that lock is released.

COOKING END REMINDING FUNCTION

When the cooking is over, the buzzer will sound 5 "beep" to alert user the cooking is finished.

OTHER SPECIFICATIONS

(1) In standby state , if the set clock digital tube displays current time, the icon " : " would flash; otherwise, it shows " 0:00 " .

(2) In setting function state, LED displays corresponding setting.

(3) In working or pause state, LED displays surplus cooking time.

Troubleshooting

Check your problem by using the chart below and try the solutions for each problem. If the microwave oven still does not work properly, contact the nearest authorized service center.

TROUBLE	POSSIBLE CAUSE	POSSIBLE REMEDY
Oven will not start	a. Electrical cord for oven is not plugged in.	a. Plug into the outlet.
	b. Door is open.	b. Close the door and try again.
	c. Wrong operation is set.	c. Check instructions.
Arcing or sparking	a. Materials to be avoided in microwave oven were used.	a. Use microwave-safe cookware only.
	b. The oven is operated when empty.	b. Do not operate with oven empty.
	c. Spilled food remains in the cavity.	c. Clean cavity with wet towel.
Unevenly cooked foods	a. Materials to be avoided in microwave oven were used.	a. Use microwave-safe cookware only.
	b. Food is not defrosted completely.	b. Completely defrost food.
	c. Cooking time, power level is not suitable.	c. Use correct cooking time, power level.
	d. Food is not turned or stirred.	d. Turn or stir food.
Overcooked foods	Cooking time, power level is not suitable.	Use correct cooking time, power level.
Undercooked foods	a. Materials to be avoided in microwave oven were used.	a. Use microwave-safe cookware only.
	b. Food is not defrosted completely.	b. Completely defrost food.
	c. Oven ventilation ports are restricted.	c. Check to see that oven ventilation ports are not restricted.
	d. Cooking time, power level is not suitable.	d. Use correct cooking time, power level.

Improper defrosting	a. Materials to be avoided in microwave oven were used.	a. Use microwave-safe cookware only.
	b. Cooking time, power level is not suitable.	b. Use correct cooking time, power level.
	c. Food is not turned or stirred	c. Turn or stir food.

Warning

This content is compiled from multiple sources and is provided for reference purposes only. It may not be complete or fully applicable to all situations. If you are unable to resolve your issue, please contact the product manufacturer or an authorized service provider for official support.

