

Parts and Features

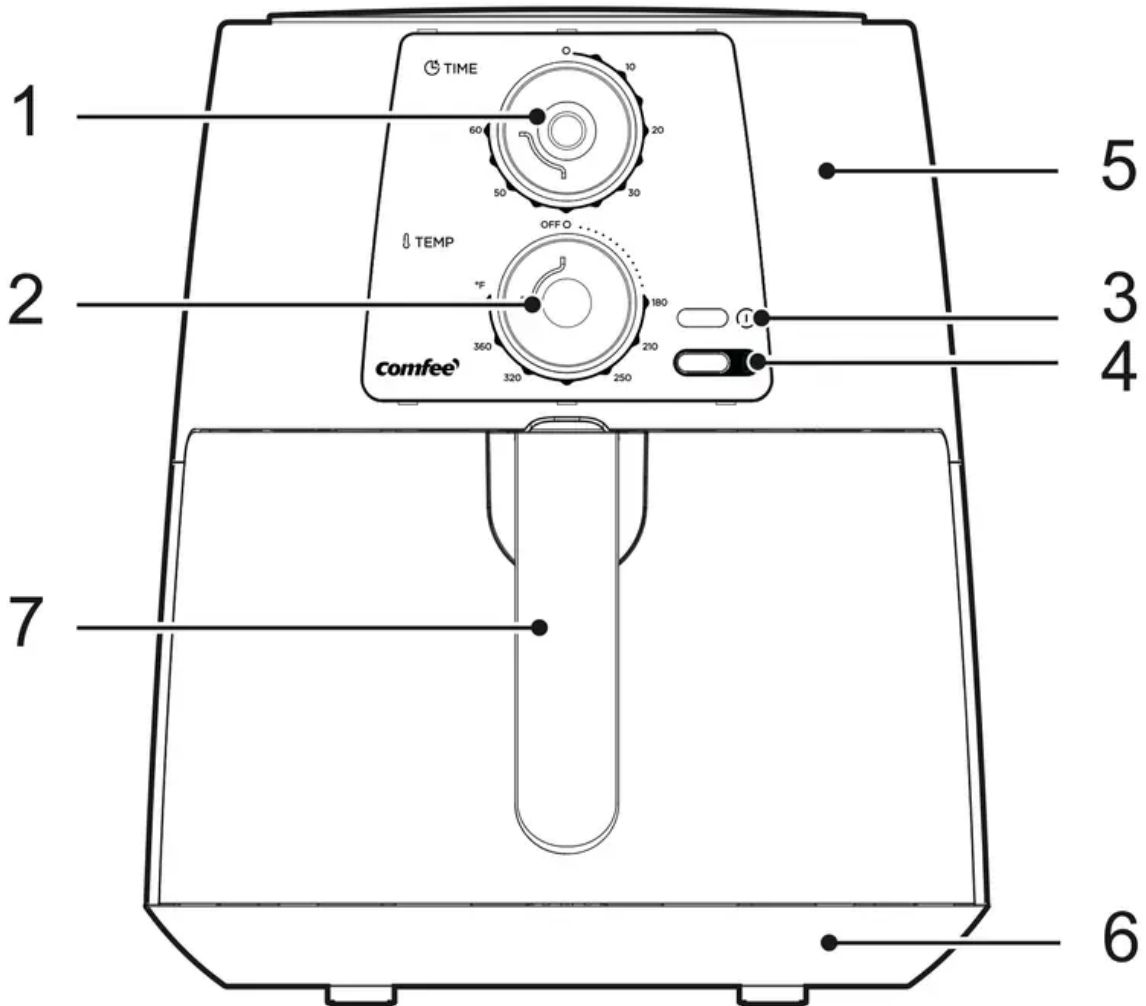

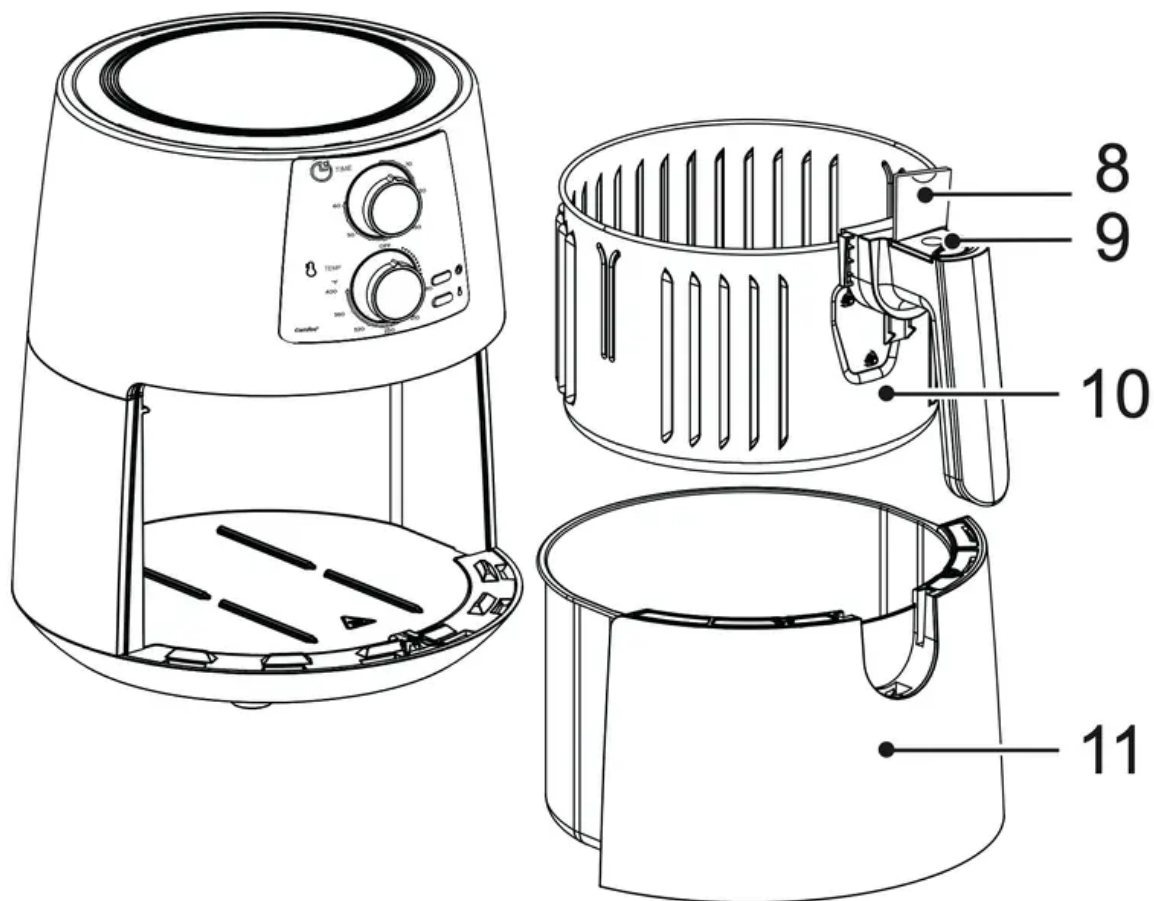

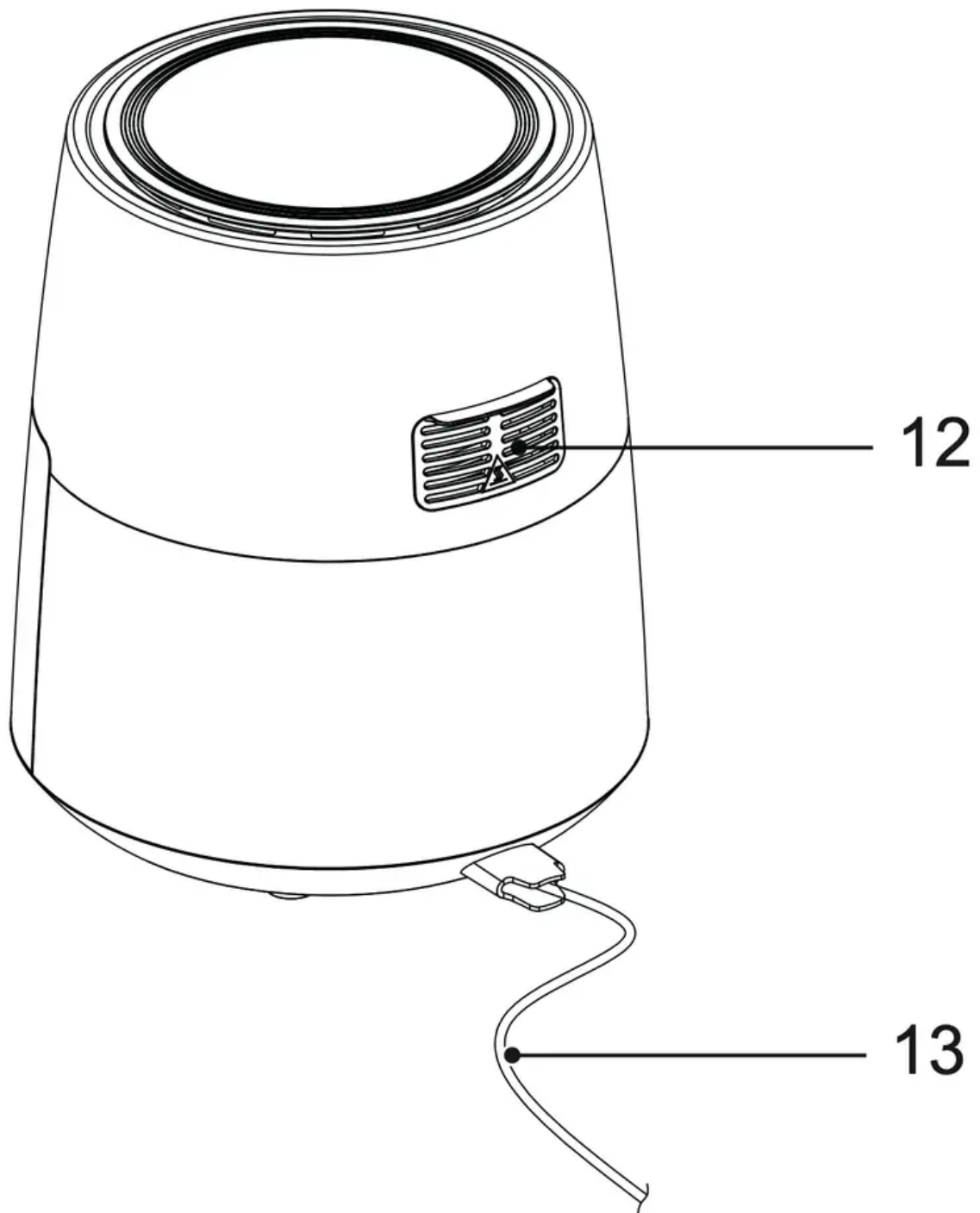

1. Power-On Dial and Timer(0-60Min)
2. Temperature Control Dial
3. Power Light Indicator
4. Heating Light
5. Plastic Housing
6. Bottom Cover
7. Basket Handle

8. Protective Button Cover
9. Basket Release Button
10. Frying basket
11. Drawer
12. Air Outlet
13. Power Cord

Overheating Protection

The appliance has an overheating protection system. If the inner temperature gets too hot, the overheating protection will automatically turn off the air fryer. The appliance can no longer be used. Unplug the appliance.

Automatic switch-off

This appliance is equipped with a timer. When the timer has counted down to 0, the appliance produces a bell sound and switches off automatically. To switch off the appliance manually, turn the timer knob anti clockwise to 0.

Note: If pull out the drawer during cooking, the appliance will be switched off automatically, too. (Timer still in counting down).

Electromagnetic fields (EMF)

This appliance complies with all standards regarding electromagnetic fields (EMF). If handled properly and according to the instructions in this user manual, the appliance is safe to use based on scientific evidence available today.

Before first use

1. Remove all packaging material.
2. Remove any stickers or labels from the appliance.
3. Thoroughly clean the basket and drawer with hot water, some washing-up liquid and a non-abrasive sponge.
4. Wipe the inside and outside of the appliance with a moist cloth.

This is an air fryer that works on hot air. Do not fill the drawer with oil or frying fat.

Preparing for use

1. Place the appliance on a stable, horizontal and level surface.
Do not place the appliance on non-heat-resistant surfaces.
2. Place the basket in the drawer properly.

3. Put the drawer into the machine.

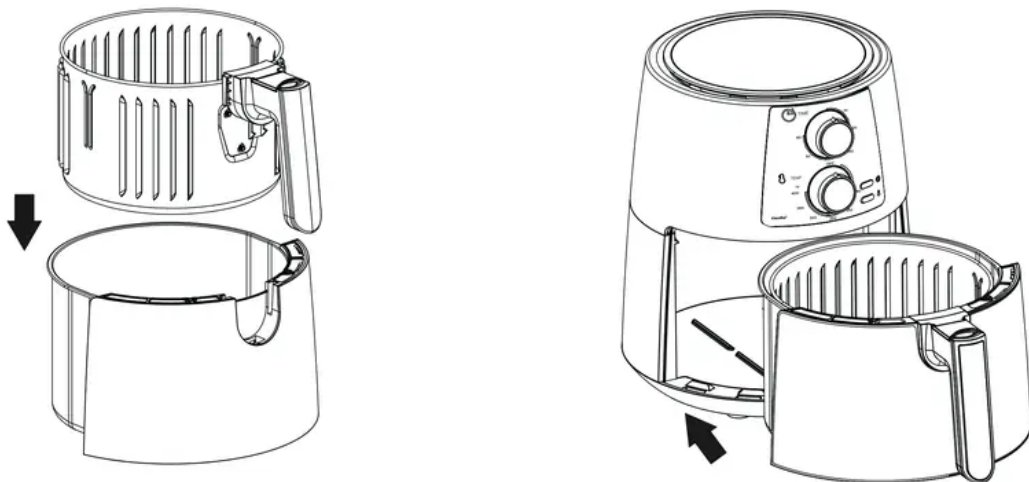

Note: The drawer MUST be put into the appliance properly, otherwise the appliance doesn't work!

4. Pull the mains cord and plug into the earthed wall socket.
Do not fill the drawer with oil or any other liquid.
Do not put anything on top of the appliance.

Using the appliance

The air fryer can prepare a large range of food content. Please refer to the section "settings" table here in after and the using guidance figures at last page.

Hot air frying

1. Put the main plug into an earthed wall socket.
2. Carefully pull the drawer out of the air fryer.
3. Put the food content in the basket.

Note: Never fill the basket or exceed the recommended amount (see section 'Settings' in this chapter), as this could affect the quality of the end result.

4. Slide the drawer back into the air fryer properly.

Never use the drawer without the basket in it.

If the drawer doesn't be fixed into the air fryer properly the appliance won't work!

Caution: Do not touch the drawer during and some time after use, as it gets very hot. Only hold the drawer by the handle.

5. Turn the temperature control knob to the required temperature. See section 'Settings' in this chapter to determine the right temperature.
6. Determine the required preparation time for the food content(see section'Settings' in this chapter).

7. To switch on the appliance, turn the timer knob to the required preparation time.

Add 3 minutes to the preparation time when the appliance is cold.

Note: If you want, you can also let the appliance preheat without any food content inside. In that case, turn the timer knob to more than 3 minutes and wait until the heating-up light goes out (after approx. 3 minutes). Then fill the basket and turn the timer knob to the required preparation time.

a. The power-on light and the heating-up light go on.

b. The timer starts counting down the set preparation time.

c. During the hot air frying process, the heating-up light comes on and goes out from time to time. This indicates that the heating element is switched on and off to maintain the set temperature.

d. Excess oil from the food content is collected on the bottom of the drawer.

8. Some food content require shaking halfway through the preparation time (see section 'Settings' in this chapter). To shake the food content, pull the drawer out of the appliance by the handle and shake it. Then slide the drawer back into the air fryer and continue to cook.

Caution: Do not press the button of the handle during shaking.

Tip: To reduce the weight, you can remove the basket from the drawer and shake the basket only. To do so, pull the drawer out of the appliance, place it on a heat-resistant surface and press the button of the handle.

Tip: If you set the timer to half the preparation time, you hear the timer bell when you have to shake the food content. However, this means that you have to set the timer again to the remaining preparation time after shaking.

Tip: If you set the timer to full preparation time, there is no timer bell during cooking before finishing, you can pull out the drawer at any time to check the food content cooking condition, the power will shut down automatically and resume after slide the drawer back into the appliance (timer always counts down in this situation).

9. The air fryer will beep and stop heating - this signals it is time to remove your food

Note: You can also switch off the appliance manually. To do this, turn the temperature control knob to 0, or pull out the drawer directly.

10. Check if the food content are ready.

If the food content are not ready yet, simply slide the drawer back into the appliance and set the timer to a few extra minutes.

11. Stirring or shaking smaller foods mid-way through the cooking process will improve the end result and can help cook more evenly.

Do not turn the basket upside down with the drawer still attached to it, as any excess oil that has collected on the bottom of the drawer will leak onto the food content.

After hot air frying, the drawer and the food content are hot.

Depending on the type of the food content in the air fryer, steam may escape from the drawer.

After hot air frying, the drawer and the inside metal cover will be extremely hot to the touch.

12. Empty the basket into a bowl or onto a plate.

Tip: To remove large or fragile food content, use a pair of tongs to lift the food content out of the basket.

13. When a batch of food content is ready, the air fryer is instantly ready for preparing another batch.

Settings

This table below helps you to select the basic settings for the food content you want to prepare.

Note: Keep in mind that these settings are indications. As food content differ in origin, size, shape as well as brand, we cannot guarantee the best setting for your food content.

Because the rapid hot air technology instantly reheats the air inside the appliance, pulling the drawer briefly out of the appliance during hot air frying barely disturbs the process.

Tips

- Smaller food content. usually require a slightly shorter preparation time than larger food content.
- A larger amount of food content only requires a slightly longer preparation time, a smaller amount of food content only requires a slightly shorter preparation time.
- Shaking smaller food content halfway through the preparation time optimizes the end result and can help prevent unevenly fried ingredients.
- Add some oil to fresh potatoes for a crispy result. Fry your food content. in the air fryer within a few minutes after you added the oil.
- Do not prepare extremely greasy food content such as sausages in the air fryer.
- Snacks that can be prepared in a oven can also be prepared in the air fryer.
- The optimal amount for preparing crispy fries is 500 grams.
- Use pre-made dough to prepare filled snacks quickly and easily. Pre-made dough also requires a shorter preparation time than home-made dough.
- Place a baking tin or oven dish in the air fryer basket if you want to bake a cake or quiche or if you want to fry fragile food content or filled food content.
- You can also use the air fryer to reheat food content. To reheat food content, set the temperature to 300°F for up to 10 minutes.

Menus	Temperature(°F)	Time(min.)
Defrost	180	5-10
Frozen Fries	400	13-18
Chicken Wings	400	17-22
Chicken Legs	400	20-25
Meat	400	10-15
Shrimp	320	6-10
Fish	360	8-15
Cake	340	8-12

Note: Add 3 minutes to the preparation time when you start frying while the air fryer is still cold.

Making home-made fries

To make home-made fries, follow the steps below.

1. Peel the potatoes and cut them into sticks.
2. Wash the potato sticks thoroughly and dry them with kitchen paper.
3. Try using cornola oil instead of olive oil to reduce smoke coming from the air fryer during the cooking process.
4. Remove the sticks from the bowl with your fingers or a kitchen utensil so that excess oil stays behind in the bowl. Put the sticks in the basket.
Note: Do not tilt the bowl to put all the sticks in the basket in one go, to prevent excess oil from ending up on the bottom of the drawer.
5. Fry the potato sticks according to the instructions in this chapter.

Cleaning

Clean the appliance after every use.

The appliance will be hot after using it. Wait for the appliance to cool down before cleaning it.

The drawer and the basket, do not use metal kitchen utensils or abrasive cleaning materials to clean them, as this may damage the non-stick coating.

1. Remove the main plug from the wall socket and let the appliance cool down.
Note: Remove the drawer to let the air fryer cool down more quickly.
2. Wipe the outside of the appliance with a moist cloth.
3. Clean the drawer and the basket with hot water, some washing-up liquid and a non-abrasive sponge.
You can use a degreasing liquid to remove any remaining dirt.

Tip: If dirt is stuck to the basket or the bottom of the drawer, fill the drawer with hot water with some washing-up liquid. Put the basket in the drawer and let the drawer and the basket soak for approximately 10 minutes.

4. Clean the inside of the appliance with hot water and non-abrasive sponge.
5. Clean the heating element with a cleaning brush to remove any food residues.

Storage

1. Unplug the appliance and let it cool down.
2. Make sure all parts are clean and dry.
3. Put the air fryer on the clean and dry place.

Troubleshooting



Problem	Possible Cause	Solution
The air fryer does not work	The appliance is not plugged in.	Put the mains plug in an earhted wall socket.
	You have not set the timer.	Turn the timer knob to the required preparation time to switch on the appliance.
	The drawer is not put into the appliance properly.	Slice the drawer into the appliance properly.
The food content fried with the air fryer are not done.	The amount of food content in the basket is too big.	Put smaller batches of ingredients in the basket. Smaller batches are fried more evenly.
	The set temperature is too low.	Turn the temperature control key to the required temperature setting (see sections 'settings' in chapter 'Using the appliance').
	The preparation time is too short.	Turn the time key to the required preparation time (see section 'Settings' in chapter 'Using the appliance')
The food content are fried unevenly in the air fryer.	Certain types of food content need to be shaken halfway through the preparation time.	Food content that lie on top of or across each other (e.g.fries) need to be shaken halfway through the preparation time.
Fried snacks are not crispy when they come out of the air fryer.	You used a type of snacks meant to be prepared in a traditional deep fryer.	Use oven snacks or lightly brush some oil onto the snacks for a crispier result.
I cannot slide the drawer into the appliance properly.	There are too much food content in the basket.	DO NOT fill the basket beyond in full, refer to the "Setting" table above.

Problem	Possible Cause	Solution
	The basket is not placed in the drawer correctly.	Push the basket down into the drawer until you hear a click.
White smoke comes out of the appliance.	You are preparing greasy food content.	When you fry greasy food content in the air fryer, a large amount of oil will leak into the drawer. The oil produces white smoke and the drawer may heat up more than usual. This does not affect the appliance or the end result.
	The drawer still contains grease residues from previous use.	White smoke is caused by grease heating up in the pan. Make sure you clean the drawer properly after each use.
Fresh fries are fried unevenly in the air fryer.	You did not use the right potato type.	Use fresh potatoes and make sure they stay firm during frying.
	You did not rinse the potato sticks properly before you fried them.	Rinse the potato sticks properly to remove starch from the outside of the sticks.
Fresh fries are not crispy when they come out of the air fryer.	The crispiness of the fries depends on the amount of oil and water in the fries.	Make sure you dry the potato sticks properly before you add the oil.
		Cut the potato sticks smaller for a crispier result.
		Add slightly more oil for a crispier result.

IMPORTANT SAFEGUARDS

When using electrical appliances, basic safety precautions should always be followed including the following:

1. Read all instructions before using this Air Fryer.
2. Do not touch hot surfaces. Use handles or knobs.
3. To prevent electric shock or short-circuit, do not immerse cord, plugs, or appliance in water or other liquid.

4. This appliance is not intended for use by persons (including children) with reduced physical, sensory or mental capabilities, or lack of experience and knowledge, unless they have been given supervision or instruction concerning use of the appliance by a person responsible for their safety.
5. Unplug from outlet when not in use and before cleaning. Allow to cool before putting on or taking off parts.
6. Do not operate any appliance with a damaged cord or plug or after the appliance malfunctions or has been damaged in any manner. Return appliance to the nearest authorized service facility for examination, repair, or adjustment.
7. Only connect the appliance to a grounded wall socket. Always make sure that the plug is inserted into the wall socket properly.
8. This appliance is intended to be used indoors. Do not use outdoors.
9. Do not let cord hang over edge of table or counter, or touch hot surfaces.
10. Do not place on or near a hot gas or electric burner, or in a heated oven.
11. Extreme caution must be used when moving an appliance containing hot oil or other hot liquids.
12. Always attach plug to appliance first, then plug cord into the wall outlet. To disconnect, turn any control to "off", then remove plug from wall outlet.
13. Do not use appliance for other than intended use.
14. Use extreme caution when removing tray or disposing of hot grease.
15. Do not clean with metal scouring pads. Pieces can break off the pad and touch electrical parts, creating a risk of electric shock.
16. Do not use for deep frying.
17. Avoid contacting moving parts.
18. Make sure the frying basket is locked into the front of the drawer - both frying basket handle tabs must be fully inserted into the notches on the top of the basket drawer.
19. Always make sure frying basket drawer is fully closed, with frying basket handle locked securely in the drawer, while Air Fryer is in operation.
20. This appliance has a polarized plug (one blade is wider than the other). To reduce the risk of electric shock, this plug is intended to fit into a polarized outlet only one way. If the plug does not fit fully into the outlet, reverse the plug. If it still does not fit, contact a qualified electrician. Do not attempt to modify the plug in any way.
 - a) A short power-supply cord should be used to reduce the risk resulting from becoming entangled in or tripping over a longer cord.
 - b) Do not use any accessories that have not been provided with the appliance.
21. **WARNING:** Air Fryer will not operate unless frying basket drawer is fully closed.

22. **CAUTION:** After hot air frying, the frying basket and frying basket drawer and the cooked foods are hot. Extreme caution must be used when handling the hot Air Fryer basket/drawer.
23. **WARNING:** After air frying, make sure to place the frying basket drawer on a flat, heat-resistant surface before pressing the basket release button.

Warning

This content is compiled from multiple sources and is provided for reference purposes only. It may not be complete or fully applicable to all situations. If you are unable to resolve your issue, please contact the product manufacturer or an authorized service provider for official support.