

Assembly Accessories

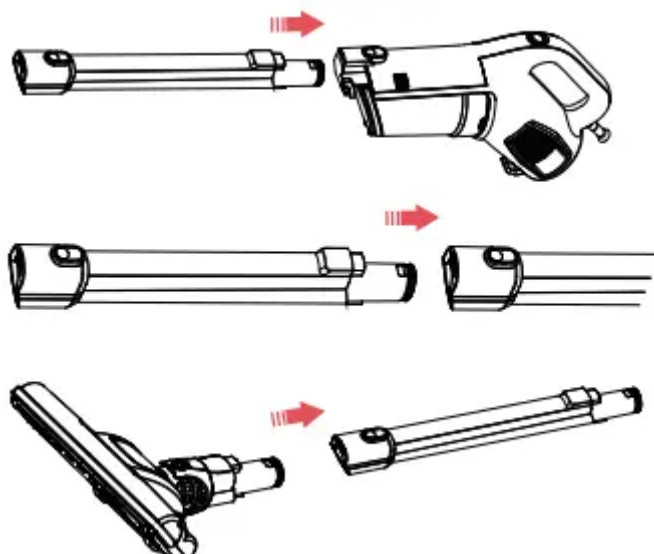

Dumping dust



Cleaning HEPA

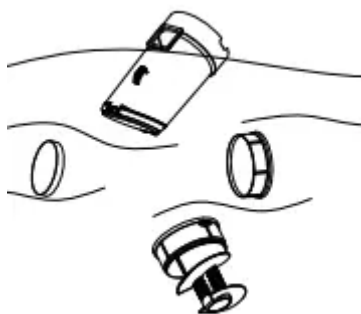

Dual-position carpet

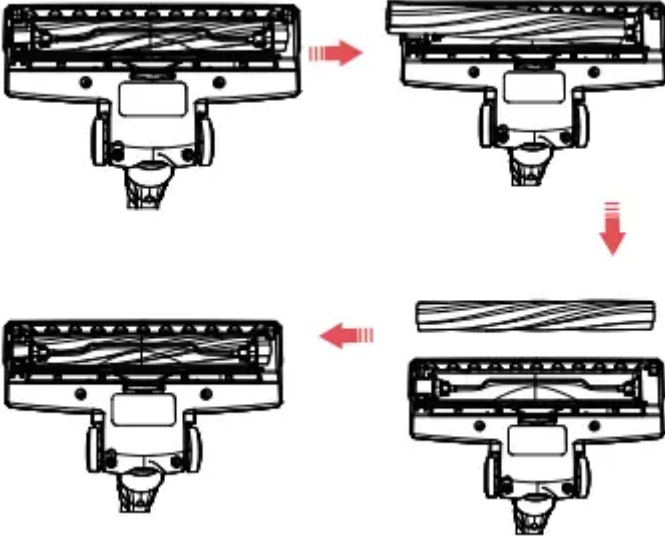

Installation dust cup/Demolition HEPA

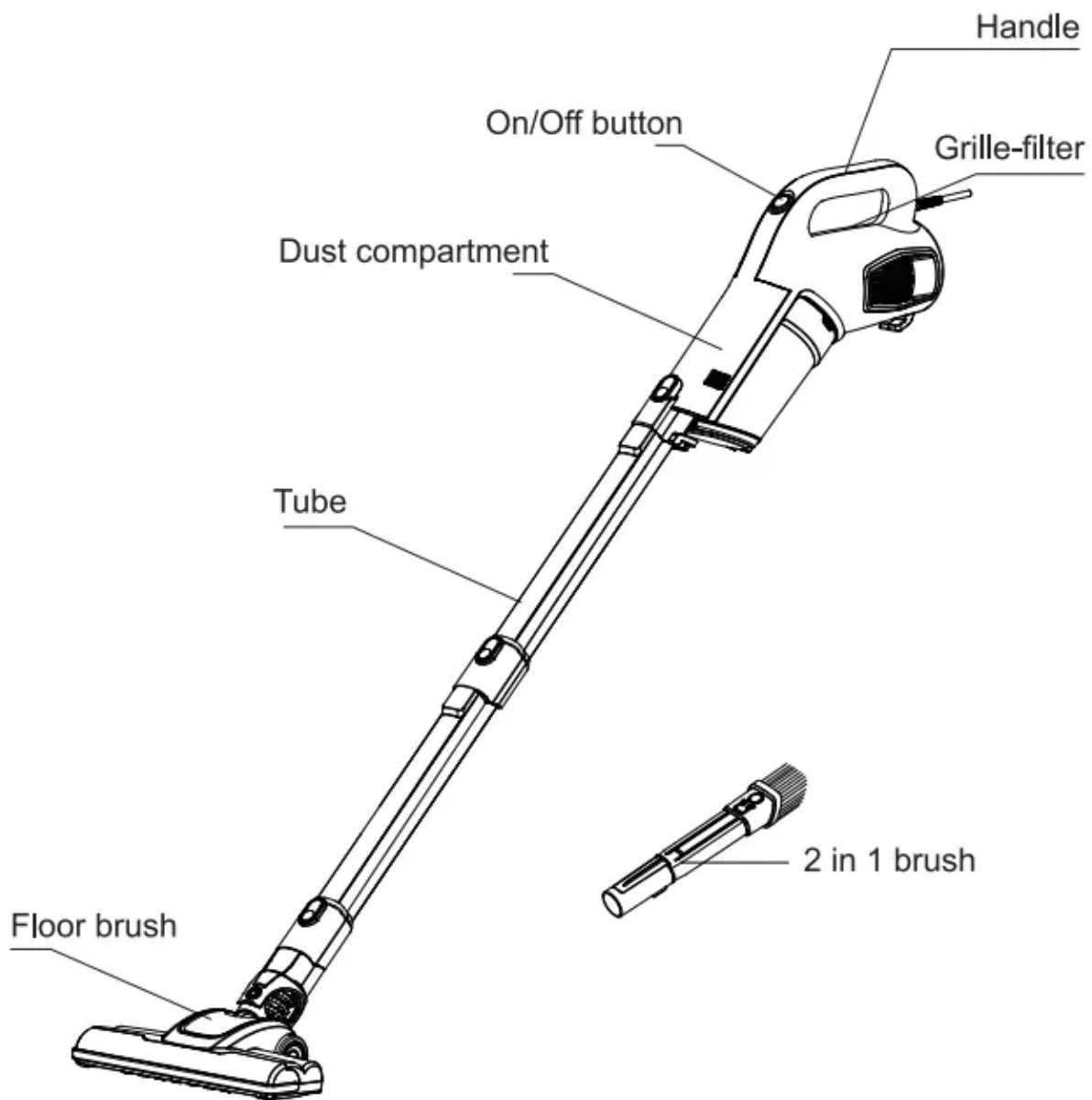
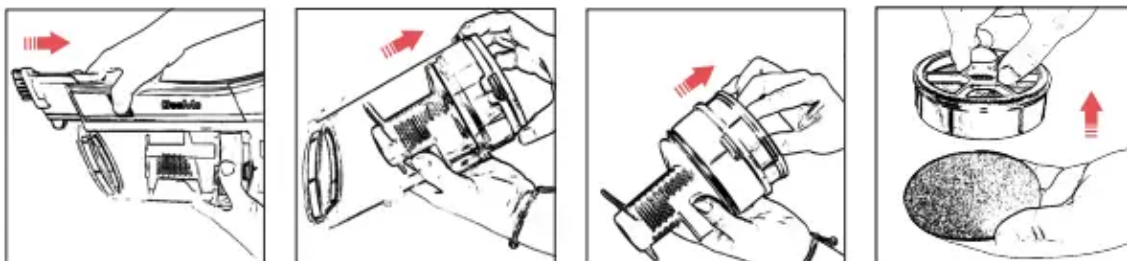

Filter maintenance



Wall hanging

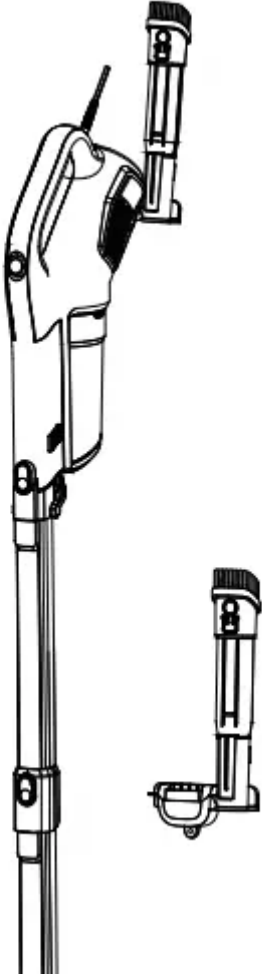

SPECIFICATIONS

Name	GeeMo Stick Vacuum
Model	H595
Vacuum	17Kpa
Rated Voltage	120V~4A~60Hz
Rated Power	500W
Power Cord Length	7m
Dust Cup	1.2L
Noise	80dB
Product Weight	2.2kg

MAINTENANCE

1. Pull the plug out of the socket before cleaning!
2. Clean the appliance with a dry cloth.
3. Take out the intake or outlet filter when it's getting dirty. Clean it in warm water without any abluent and put it back when it is completely dry.
4. If you don't want to use this appliance for a period of time. store it on a dry and well-ventilated place. Keep it out of reach of children.

CUSTOMER CARE

- The 2-Year Limited Warranty is valid for products purchased from our GeeMo only. starting from the date of original retail purchase against defects in quality and materials under normal, non-commercial use. According to the requirements outlined in this instruction manual, subject to the following conditions and exclusions.
- If you have a query about your GeeMo appliance, please contact the GeeMo customer service email: usa@igee mo.com.
- Please inform us your model name/umber. purchase date order number. machine problem and your requirement. Your model number can be found on rating plate. For information on your rating plate see the inside front cover. Please keep your purchase receipt in a safe place to ensure you have this information. Service under this warranty will not extend the period of this warranty

- The repair or replacement of your GeeMo appliance if your GeeMo appliance is found to be defective due to faulty materials, workmanship or function within 2 years of purchase or delivery (if any part is no longer available or out of manufacture, GeeMo will replace it with a functional replacement part) This warranty provides, at no extra cost to you, all labor and parts necessary to ensure your machine is in proper operating condition during the warranty period.
- Under your GeeMo guarantee, GeeMo shall not be liable for costs of repair or replacement of a product incurred as a result of: Accidental damage, faults caused by negligent use or care, misuse, neglect, careless operation or handling of the GeeMo appliance which is not in accordance with this GeeMo Operating Manual; Machines purchased from an unauthorized dealer; Use of parts and accessories other than those produced or recommended by GeeMo

WARNING

- Before using the appliance, check that the mains power voltage corresponds to the voltage shown on the rating plate
- The appliance should be connected to a correctly-earthed 10 power socket.
- Always remove the plug from the power socket when the appliance is not in use and before carrying out any cleaning or maintenance operations.
- Always remove the plug from the power sockets before opening the appliance.
- Never use methylated spirits or other solvents to clean the appliance.
- Do not use the appliance to vacuum liquids.
- Never leave the appliance unattended when it is switched on. Keep the appliance out of the reach of children or the infirm.
- This appliance is for domestic use only. Use as described in this instruction booklet.
- Do not switch the appliance on if it appears to be faulty in any way.
- For repairs or accessories, contact your dealer or an authorized Service Center.
- If the supply cord is damaged, it must be replaced by the manufacturer or its service agent or a similarly qualified person in order to avoid a hazard.

Frequently Asked Questions

1. Where can I buy Gee Mo H 595 Vacuum Cleaner 4 In 1 Stick Vacuum 17 Kpa Powerful Suction online at the best price in the Panama?

- Desertcart is the best online shopping platform where you can buy Gee Mo H 595 Vacuum Cleaner 4 In 1 Stick Vacuum 17 Kpa Powerful Suction from renowned brand(s).

desertcart delivers the most unique and largest selection of products from across the world especially from the US, UK and India at best prices and the fastest delivery time.

2. Is Gee Mo H 595 Vacuum Cleaner 4 In 1 Stick Vacuum 17 Kpa Powerful Suction available and ready for delivery in Panama?

- Desertcart ships the Gee Mo H 595 Vacuum Cleaner 4 In 1 Stick Vacuum 17 Kpa Powerful Suction to and more cities in Panama. Get unlimited free shipping in 164+ countries with desertcart Plus membership. We can deliver the Gee Mo H 595 Vacuum Cleaner 4 In 1 Stick Vacuum 17 Kpa Powerful Suction speedily without the hassle of shipping, customs or duties.

3. Is it safe to buy Gee Mo H 595 Vacuum Cleaner 4 In 1 Stick Vacuum 17 Kpa Powerful Suction on desertcart?

- Yes, it is absolutely safe to buy Gee Mo H 595 Vacuum Cleaner 4 In 1 Stick Vacuum 17 Kpa Powerful Suction from desertcart, which is a 100% legitimate site operating in 164 countries. Since 2014, desertcart has been delivering a wide range of products to customers and fulfilling their desires. You will find several positive reviews by desertcart customers on portals like Trustpilot, etc. The website uses an HTTPS system to safeguard all customers and protect financial details and transactions done online. The company uses the latest upgraded technologies and software systems to ensure a fair and safe shopping experience for all customers. Your details are highly secure and guarded by the company using encryption and other latest softwares and technologies.

Warning

This content is compiled from multiple sources and is provided for reference purposes only. It may not be complete or fully applicable to all situations. If you are unable to resolve your issue, please contact the product manufacturer or an authorized service provider for official support.