

## YOUR THERMOSTAT REPLACES

Description	
Standard Heating & Cooling Systems - 4 or 5 wires	No
Standard Heat Only Systems	Yes
Millivolt Heat Only Systems - Floor or Wall Furnaces	Yes
Standard Central Air Conditioning	No
Gas or Oil Heat	Yes
Electric Furnace	Yes
Hydronic (Hot Water) Zone Heat - 2 Wires	Yes
Hydronic (Hot Water) Zone Heat - 3 Wires	No
Heat Pump	No
Baseboard Electric Heating or Line Voltage (120 or 240 Volt)	No

## PREPARATIONS

Assemble tools required as shown below.



FLAT BLADE SCREWDRIVER



WIRE CUTTER/STRIPPER

*Failure to follow and read all instructions carefully before installing or operating this control could cause personal injury and/or property damage*

## THERMOSTAT FEATURES

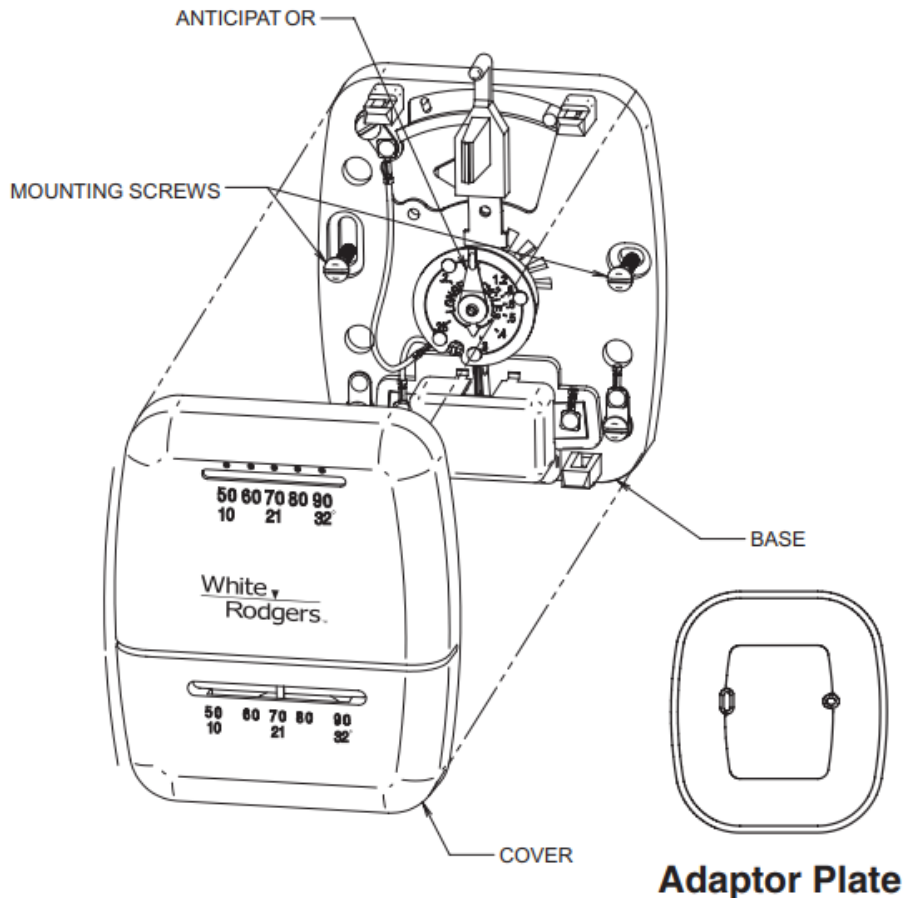

Figure 1.

## REMOVING OLD THERMOSTAT

Before removing wires from old thermostat's switching subbase, label each wire with the terminal designation it was removed from.

1. Remove Old Thermostat: A standard heat thermostat consists of two basic parts:
  - a. The cover, which may be either a snap-on or hinge type.
  - b. The base, which is removed by unscrewing the mounting screws that hold it on the wall or adaptor plate.

Make a note here  of the anticipator setting on the old thermostat for future reference and use in step 5.

The heat anticipator pointer, if adjustable, will be set at one of a series of numbers representing the current rating of the primary control in your furnace. The number will be one of the following: .2, .4, .8, etc. or 0.2, 0.4, 0.8, etc.

If no heat anticipator/indication is showing, do not be concerned; move on to the next step

**ATTENTION!** This product does not contain mercury. However, this product may replace a unit which contains mercury. Do not open mercury cells. If a cell becomes damaged, do not touch any spilled mercury. Wearing non-absorbent gloves, take up the spilled mercury and place into a container which can be sealed. If a cell becomes damaged, the unit should be discarded.

Mercury must not be discarded in household trash. When the unit this product is replacing is to be discarded, place in a suitable container. Refer to Thermostat-recycle website for location to send the product containing mercury

## MOUNTING AND WIRING

A. Mount base and adaptor plate: Mount base to wall using screws provided (see Fig. 1).

B. Attach wires: Attach one wire to R and the other wire to W on base.

## SET HEAT ANTICIPATOR

Set anticipator to match the setting of your old thermostat you noted in Step 3, or, the anticipator should be set to match the current rating stamped on your main heating control. The heat anticipator is adjustable from 0.15 to 1.2 amps. Adjust the anticipator by rotating the contact arm (see fig. 2). The anticipator setting is indicated by the numbers on the base that the pointer points to. If you are unsure where to set the anticipator contact the heater manufacturer for a recommended setting

Move the pointer counterclockwise to lengthen heating system cycles; move clockwise to shorten heating cycles. Adjustments should not be greater than 1/2 marking at a time.

**Snap on Cover:** Carefully align the cover with the base and snap the cover onto the base.

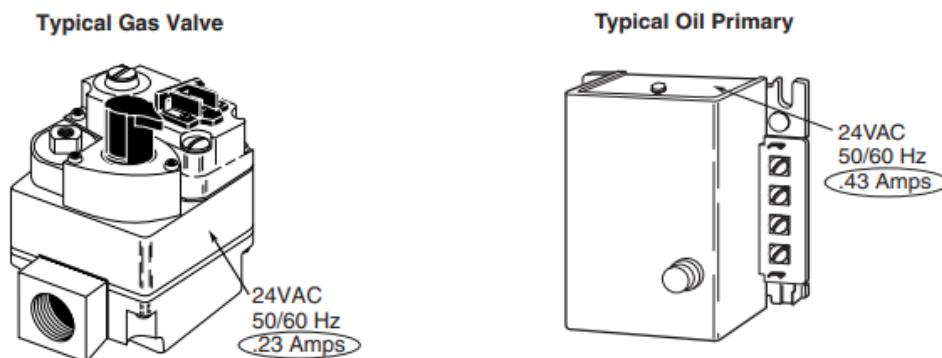

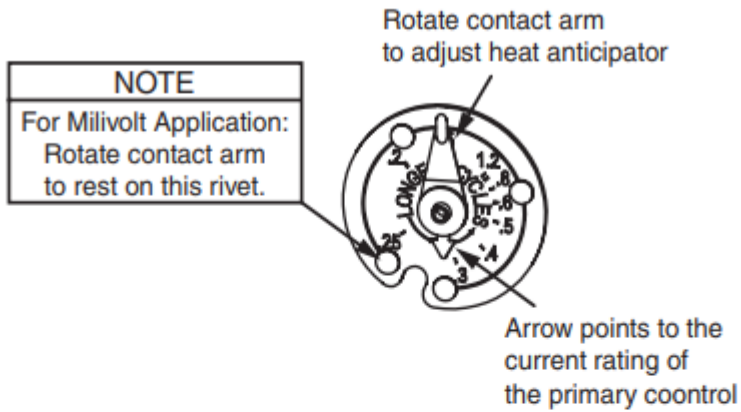

**Figure 2. Anticipator adjustment**

**Typical Zone Valve**

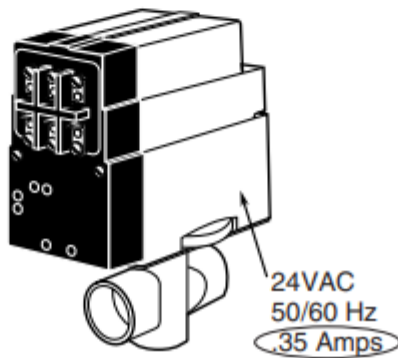

**NEW THERMOSTAT OPERATION**

After power is turned on, slide temperature lever to desired setting. To turn heat off, slide lever all the way to the left until it clicks.

**SPECIFICATIONS**

**ELECTRICAL DATA**

Switch Rating .....24 VAC (30 VAC max.)

Heating .....0.15 to 1.2 Amps

Switch Action .....Snap Action

**Anticipator Rating:**

Heating .....Adjustable from 0.15 to 1.2 Amps



**THERMAL DATA:**

Temperature Range.....50°F to 90°F (10°C to 32°C)

Operating Humidity Range ...0 – 90% noncondensing



# TROUBLESHOOTING



<b>Symptom</b>	<b>Possible Cause</b>	<b>Corrective Action</b>
No Heat	1. Blown fuse or tripped circuit breaker.	Replace fuse or reset breaker.
	2. Furnace power switch to OFF.	Turn switch to ON
	3. Furnace blower compartment door or panel loose or not properly installed.	Replace door panel in proper position to engage safety interlock or door switch.
	4. Pilot light not lit.	Re-light pilot
	5. Broken or melted anticipator wire.	Excessive current or dead short in system. Have a qualified service person check the system.
	6. Loose connection to thermostat or system.	Verify thermostat and system wires are securely attached.
	7. Thermostat or heating system requires replacement or service.	Your furnace manufacturer or service person can describe how to test the heating system to verify it is operating correctly. If the heating system is capable of operation and the no heat condition persists, replace the thermostat.
Intermittent Heat	1. Furnace Lock-Out Condition	Many furnaces have safety devices that shut the system down when a lock-out condition occurs. If the heat works intermittently contact the furnace manufacturer or local service person for assistance
Heat Runs Constantly	1. Possible short in wiring. 2. Possible short in thermostat.	Check each wire connection to the thermostat to verify it is neatly looped under the terminals. No extra wire should stick out from under the terminals.

	3. Possible short in heat system.	
Furnace Cycles Too Fast or Too Slow Narrow or wide temperature swing	See Step 5, Adjusting the Anticipator.	The anticipation setting is the only adjustment that effects the heating cycle rate. If an acceptable cycle rate is not achieved using the anticipator contact a local service person for additional suggestions. The location of the thermostat, size of the Heat/Cool System and current draw can influence the cycle rate.
Thermostat Setting and Thermostat Thermometer Disagree	1. Thermostat thermometer setting requires adjustment. 2. Thermostat setting lever requires calibration.	The thermometer can be adjusted by using a standard slotted screwdriver. Turn the thermometer pointer screw located inside the front cover to change the setting. For calibrating the setting lever contact a local heating and cooling service person.
Adjusting Thermometer	1. Thermostat thermometer disagrees with other room thermometers.	The thermometer on the thermostat is accurately calibrated at our factory but you can adjust it by using a standard slotted screwdriver. Turn the thermometer pointer screw located inside the front cover to change the setting.

**Warning**

This content is compiled from multiple sources and is provided for reference purposes only. It may not be complete or fully applicable to all situations. If you are unable to resolve your issue, please contact the product manufacturer or an authorized service provider for official support.

