

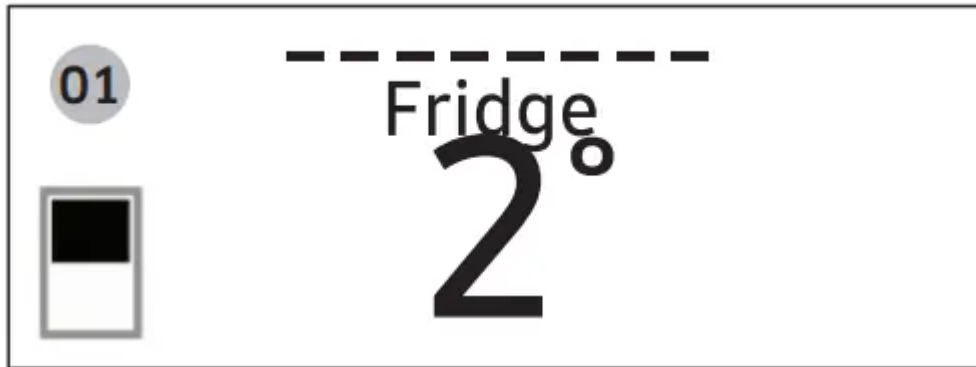



## Operations

### Control panel



01. Display	Displays the menu, settings, and other information.
02. Buttons	<ul style="list-style-type: none"><li>• When the display is off, tap any button to wake up the display.</li><li>• Tap &lt; or &gt; to navigate left and right.</li><li>• Tap  to confirm your selection.</li><li>• Tap and hold to enter the AP mode. (For more information, see the "SmartThings &gt; Getting started" section on page 48.)</li></ul>

### Using the control panel

1. Tap any button ( <, , or > ) to wake up the display.
2. Tap < or > to select the desired menu, and then tap  to confirm.
3. Tap < or > to select the desired setting, and then tap  to confirm.

- For more information on available settings, see the Menu descriptions section.

## **Menu descriptions**

Fridge	<ul style="list-style-type: none"> <li>• You can set the fridge temperature from 34 ~ 44 °F (1~7 °C) or set the Power Cool function.</li> <li>• Power Cool speeds up the cooling process at maximum fan speed. The fridge keeps running at full speed for two and a half hours and then returns to the previous temperature.</li> </ul>
Freezer	<ul style="list-style-type: none"> <li>• You can set the freezer temperature from -8 ~ 5 °F (-23 ~ -15 °C) or set the Power Freeze function.</li> <li>• Power Freeze speeds up the freezing process at maximum fan speed. The freezer keeps running at full speed for 50 hours and then returns to the previous temperature. To freeze large amounts of food, activate Power Freeze for at least 20 hours before putting food in the freezer.</li> </ul>
FlexZone	<ul style="list-style-type: none"> <li>• You can set the FlexZone mode from one of the following modes. <ul style="list-style-type: none"> <li>- Freeze: The temperature sets to the same temperature as the freezer.</li> <li>- Soft Freeze: The temperature sets to 23 °F (-5 °C).</li> <li>- Meat/Fish: The temperature sets to 30 °F (-1 °C).</li> <li>- Fruit/Veggies: The temperature sets to 36 °F (2 °C).</li> <li>- Beverage: The temperature sets to 39 °F (4 °C).</li> </ul> </li> </ul>
Flex Crisper *	<ul style="list-style-type: none"> <li>• You can set the Flex Crisper mode from one of the following modes. <ul style="list-style-type: none"> <li>- Fridge: The temperature sets to the same temperature as the fridge.</li> <li>- Meat/Fish: Select this mode to store meat and fish fresh. (We recommend setting the fridge temperature below 37 °F (3 °C) to store meat and fish fresher in the Flex Crisper)</li> </ul> </li> </ul>
AutoFill Pitcher *	<ul style="list-style-type: none"> <li>• You can set the AutoFill Pitcher mode from one of the following modes. <ul style="list-style-type: none"> <li>- On: Set to fill your water pitcher automatically.</li> <li>- Off: Set to turn off the function.</li> </ul> </li> </ul>
	<p>You can start or stop making cubed ice.</p>

Cubed Ice * (Ice Maker *)	
Ice Bites *	You can start or stop making ice bites.
More Options	<p>You can change the settings for the following functions. Tap &lt; or &gt; to select the menu, and then tap  to confirm.</p> <p><b>UV Deodorizing Filter *</b>: You can turn the UV Deodorizing Filter on or off.</p> <p><b>Peak Demand *</b>: You can turn the Peak Demand function on or off. (For more information on Peak Demand function, see the SMART GRID Function (Demand Response, applicable models only) section on page 50.)</p> <p><b>Filter Reset *</b>: When you get the filter replacement message on the display, select this menu, and replace the filter according to onscreen instructions.</p> <p><b>Temp. Unit</b>: You can set the temperature scale to Celsius or Fahrenheit.</p> <p><b>Door Alarm</b>: You can turn on or off the Door Alarm.</p> <p><b>Wi-Fi Connect</b>: You can turn on or off the Wi-Fi Connect. Turn it on to control and monitor your refrigerator on the SmartThings app. (For more information on SmartThings, see the SmartThings section on page 47.)</p>

### Activating or deactivating the Sabbath mode

The Sabbath mode stays active for 85 hours once it is activated. After that, it will be deactivated automatically.

- To activate or deactivate the Sabbath mode, tap and hold  and > simultaneously for 6 seconds. Then, tap > .

- When the refrigerator is in the Sabbath mode, the buttons, display, and internal lights do not function. The refrigerator and freezer, however, continue to cool.

### Activating or deactivating the Cooling Off mode



The Cooling Off mode (also called the Shop mode) is designed for retailers to display refrigerators on a retail floor. In the Cooling Off mode, the refrigerator's fan motor and lights operate normally, but the compressors do not run, so neither the refrigerator nor the freezer becomes cold.

- To activate or deactivate the Cooling Off mode, tap and hold < and >

simultaneously for 6 seconds. Then, tap .

- When the Cooling Off mode is on, the refrigerator chime sounds, and the refrigerator shows the "Cooling Off mode turned on" message.

## SmartThings

### Installation

Visit the Google Play Store, Galaxy Apps, or Apple App Store and search for "SmartThings". Download and install the SmartThings app provided by Samsung Electronics to your smart device.

### Samsung account

You are required to register your Samsung account to use the app. If you don't have a Samsung account, follow the app's onscreen instructions to create a free Samsung account.

### Getting started

Turn on the device you want to connect, open the SmartThings app on your phone, and then follow the instructions below. If a pop-up appears saying that a new device has been found, tap ADD NOW. If a pop-up doesn't appear, tap the + button, and then select the device you want to connect from the list of available devices. If your device isn't in the list of available devices, tap Supported Devices, select the device type (Refrigerator), and then select the specific device model. Follow the instructions in the app to set up your device. Once setup is complete, your refrigerator will appear as a "card" on your Devices screen.

## Refrigerator app

### Integrated control

You can monitor and control your refrigerator at home and on the go.

- Tap the refrigerator icon on the SmartThings Dashboard or tap the Devices icon at the bottom of the Dashboard, and then tap the refrigerator "card" to open the Refrigerator page.
- Check the operation status or notifications related to your refrigerator, and then change options or settings if necessary.

Category	Item	Description
Monitoring	Fridge temperature	Displays the desired temperature setting of the fridge
	Freezer temperature	Displays the desired temperature setting of the freezer.
	FlexZone settings	Displays the settings of the FlexZone.
	Diagnosis	Detects abnormal operations of the refrigerator.
	Energy monitoring	Checks the accumulated power consumption of the refrigerator for the last 180 days.
Functions	Ice making	You can turn the ice making function on or off, and check the current settings of the function.
		You can also check the status and progress of ice making.
	Power Cool	You can turn Power Cool on or off, and check the current settings.
	Power Freeze	You can turn Power Freeze on or off, and check the current settings.
	Fridge temperature	You can set the desired temperature of the fridge.
	Freezer temperature	You can set the desired temperature of the freezer.
	FlexZone settings	You can set the desired FlexZone mode.
	Sabbath Mode	You can activate and deactivate the Sabbath mode.
Alarms	Abnormally high temperature	This alarm is triggered when the fridge, the freezer, or the FlexZone has abnormally high temperatures.
	Door opening	This alarm is triggered if the fridge door, the freezer drawer, or the FlexZone drawer is open for a specific time.

AutoFill Pitcher overflowing	If the AutoFill Pitcher function senses an overflow, it triggers this alarm to let you know the status of the overflow
Water filter replacement	This alarm reminds you that the water filter must be replaced.

### **SMART GRID Function (Demand Response, applicable models only)**

When the refrigerator operates in SMART GRID (Demand Response) mode, the Energy Management Refrigerator function can control energy usage or delay the operation of some functions to save money when energy prices or demand are the highest.

In addition, to use the Smart Grid (Demand Response) function, you must register for the service with your electric company. The company must have an EMS (Energy Management System) that supports SEP (Smart Energy profile).

#### **Using the SMART GRID (Demand Response) Function**

This feature monitors energy prices and demand information from your utility company and sends notifications to the refrigerator to run high energy consuming tasks during offpeak times when electricity costs and demand are lower. If the refrigerator receives a control signal from the utility company, the refrigerator will display the DAL ~ TALR levels on the refrigerator display and control the power consumption according to the level. [Exception condition] The DAL and TALR control signals from a utility company work as long as product performance is maintained. If the refrigerator receives the SMART GRID (Demand Response) signal (DAL or TALR), the refrigerator will operate in Delay Appliance Load (DAL) or Temporary Appliance Load Reduction (TALR) mode.

- Delay Appliance Load (DAL): The refrigerator responds to a DAL signal by providing a moderate load reduction for the duration of the delay period. This function controls functions that consume a lot of energy such as adjusting the Cooling system, running the defrost cycle, and making ice.
  - When the refrigerator operates in DAL mode, "DAL" is displayed on the refrigerator display.
  - DAL mode is automatically deactivated after it lasts for the amount of time stipulated by the DAL signal (max. 4.5 hours) or when you turn off the Peak Demand function
- Temporary Appliance Load Reduction (TALR): The refrigerator responds to a TALR signal by aggressively reducing the load for a short time period. This function reduces energy consumption by stopping the compressor and





controlling the functions that consume a lot of energy such as the defrost cycle and making ice.

- When the refrigerator operates in TALR mode, "TALR" is displayed on the refrigerator display.
- TALR mode is automatically deactivated after it lasts for the received duration (max. 15 minutes), or when you turn off the Peak Demand function. The mode is immediately deactivated and the refrigerator returns to the normal state when the door is opened or closed, or the dispenser is used.

### **Peak Demand Off**

When you want the refrigerator to ignore the SMART GRID (Demand Response) signal from the utility company, you can turn off the Peak Demand function. When you turn off the Peak Demand function, the refrigerator ignores the SMART GRID (Demand Response) signal and is not controlled by the utility company.

### **Turning on or off the Peak Demand function**

1. Tap any button (< ,  , or >) to wake up the display.
2. Tap < or > to select More Options, and the tap  to confirm.
3. Tap < or > to select Peak Demand, and then tap  to confirm.
4. Tap < or > to select On or Off, and then tap to confirm.

### **Using the Energy Management Function**

The Energy Management function enables you to control and monitor your Energy Management refrigerator using the SmartThings app for your convenience.

1. Operational Status - You can check the DR and Peak Demand status.
2. Energy Consumption Reporting - Shows the accumulated power consumption. Power consumption data is updated every 10 minutes.
3. Delay Defrost Capability
  - The Delay Defrost Capability function saves energy by delaying the defrost operation to a time specified by the user. You can configure the time. and this function will save energy during the specified period in a 24 hour cycle. If the time is not set, the function works with the default time settings. The default time settings are below:
    - 6 am to 10 am: 1st. November ~ 30th. April
    - 3 pm to 7 pm: 1st. May ~ 31th. October

To change the time setting for the Delay Defrost Capability You can change the time setting for the Delay Defrost Capability on the app

### **Provision for Open Access to the Connected Product Requirements**

#### 1. SGIP Open Standards (Smart Energy Profile 2.0)

- Energy Consumption Reporting
- Demand Response

#### 2. Samsung OPEN API

- Operational Status, User Settings & Messages - ICE Maker  
Status: GET /icemaker/status/vs/0
- Door Open Alarm: GET /doors/vs/0
- DR Status: GET /drlc/vs/0
- Delay Defrost Capability
- Set Schedule of the Defrost Delay: POST /defrost/reservation/vs/0?op=add
- Get Schedule of the Defrost Delay : GET /defrost/reservation/vs/0
- Delete Schedule of the Defrost Delay: POST /defrost/reservation/vs/0?op=remove
- Defrost Delay On/OFF: POST /defrost/delay/vs/0

### **Special features**

#### **Water pitcher (AutoFill Pitcher) (applicable models only)**

Cold, purified water is always ready in the AutoFill Pitcher. You can put tea or fruits in the infuser to enjoy the various infused water you like.

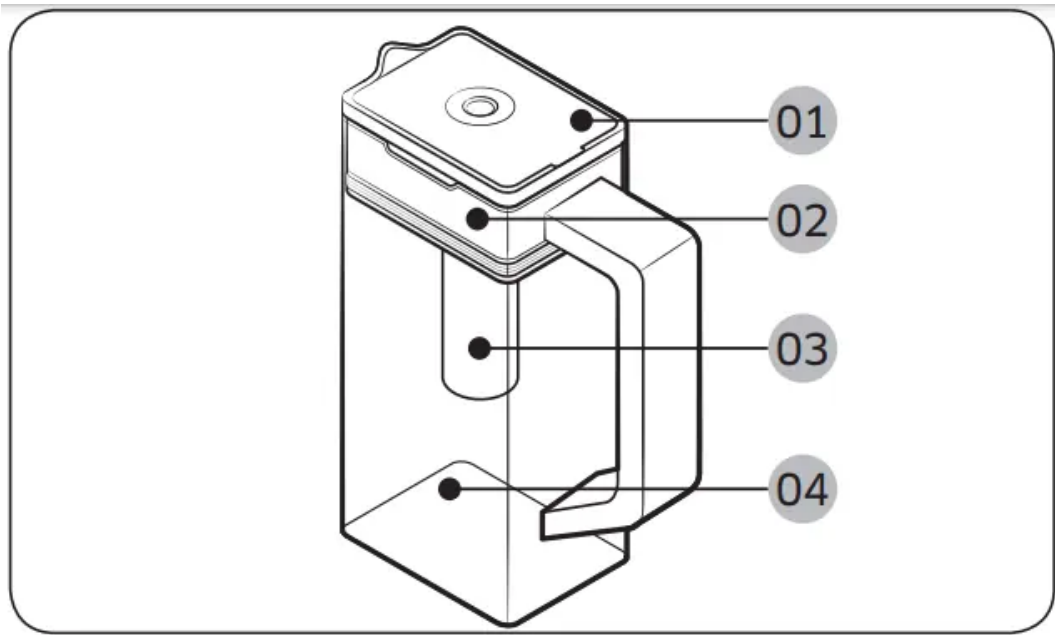

01. Lid

02. Infuser holder

03. Infuser

04. Body

To fill the Water pitcher

1. Grasp a handle groove of the lid, and then pull up to open the lid.
2. Put tea leaves or fruit to your taste into the infuser.

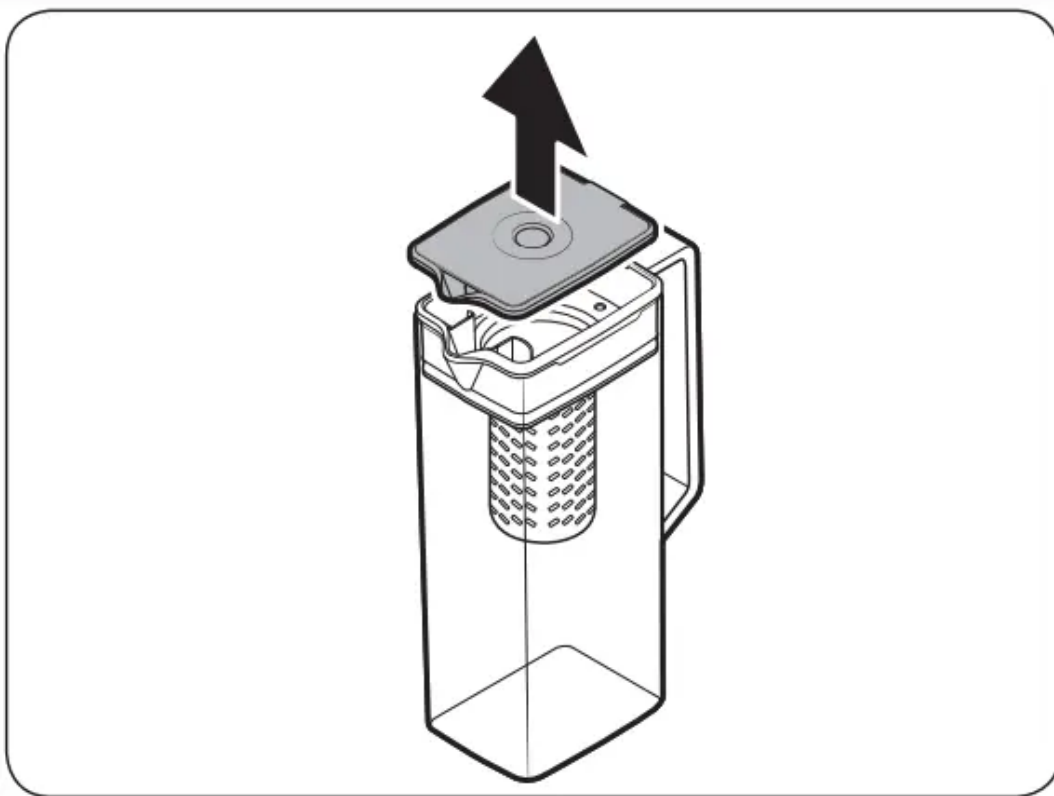

3. Enable the AutoFill Pitcher function on the control panel. Open the Beverage Center door (Type A) or the left door of the fridge (Type B), and then mount the water pitcher onto the holder. Push it straight in as shown in the figure.

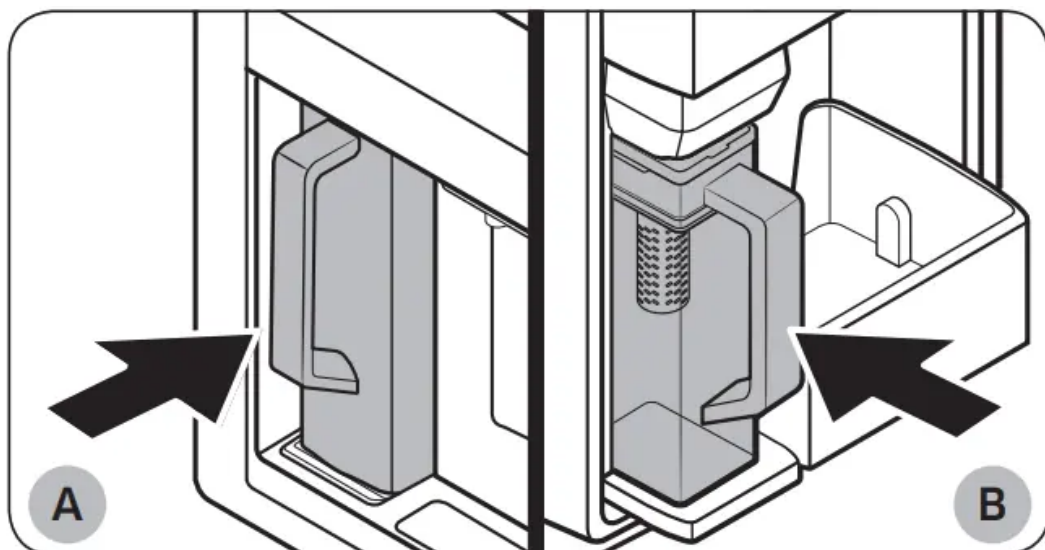

A. Type A models

B. Type B models

4. Close the door. The water pitcher will start to fill with chilled water a short time later.

5. To drink tea, open the Beverage Center door (Type A) or the left door of the fridge (Type B), and then detach the water pitcher. Pull it straight out.

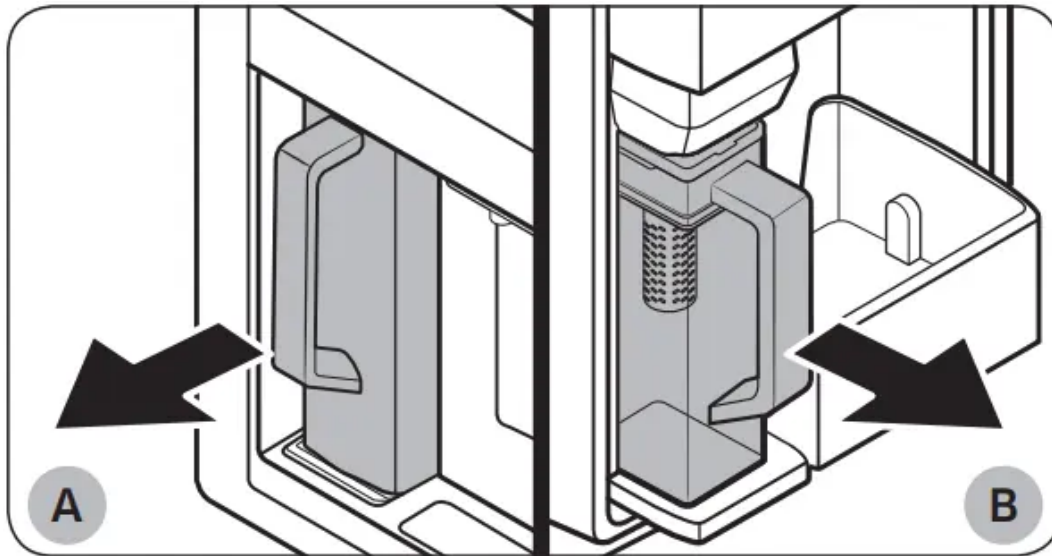

A. Type A models

B. Type B models

### **Water dispenser (applicable models only)**

To dispense chilled water, open the Beverage Center and press the dispenser lever.

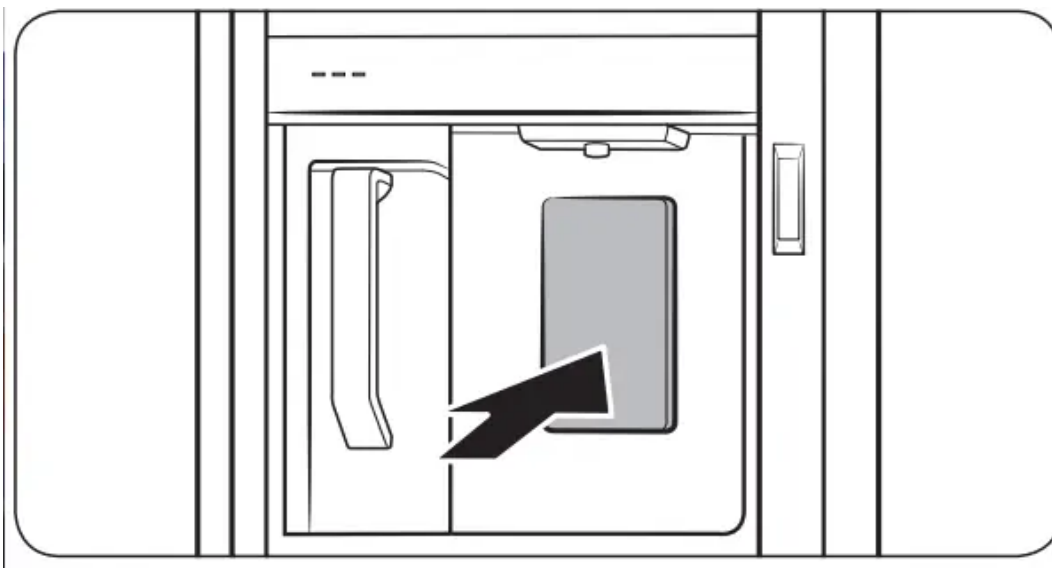

### **Water clouding**

Water supplied to the refrigerator flows through a core alkaline filter. During this filtering process, the water pressure of the water increases and the water becomes saturated with oxygen and nitrogen. This causes the water to look misty or cloudy temporarily when dispensed. This is normal and the water will look clear after a few seconds.

## Ice maker

The refrigerator has a built-in ice maker that automatically dispenses ice.

- The overall design and/or accessories may differ with the model.

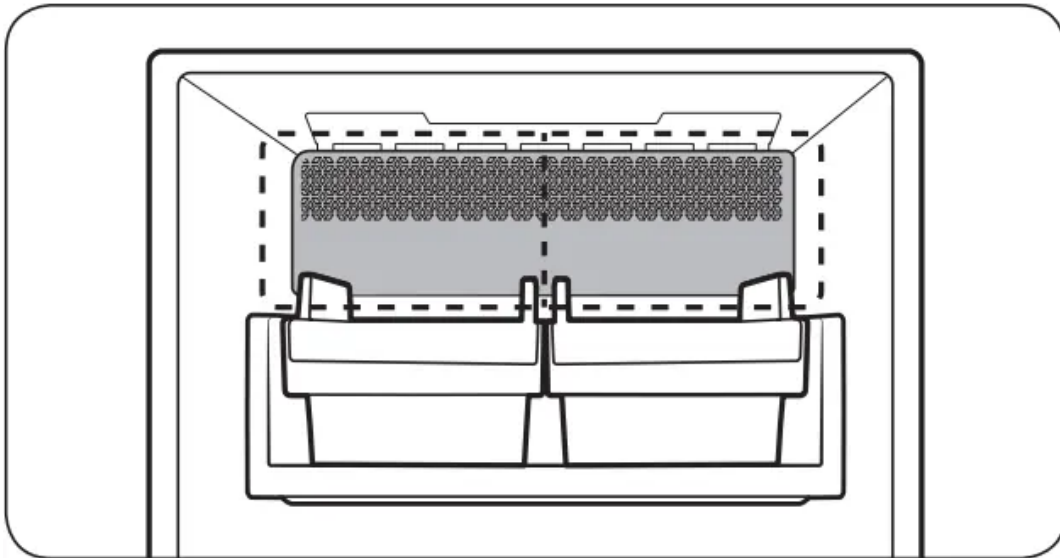

- This product has two types of ice makers.

### Ice making

After you have installed your refrigerator and plugged it in, follow these instructions to ensure proper ice making and to keep the ice bucket full of ice.

#### For first-time use

- Let the ice maker make ice for 1-2 days.
- Discard the first 1-2 buckets of ice to remove impurities in the water supply system.

### Diagnosis

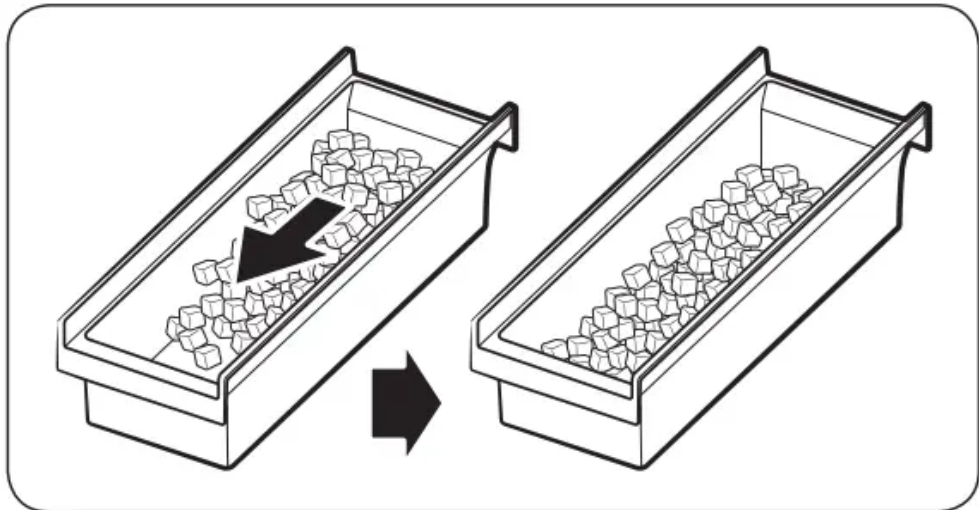
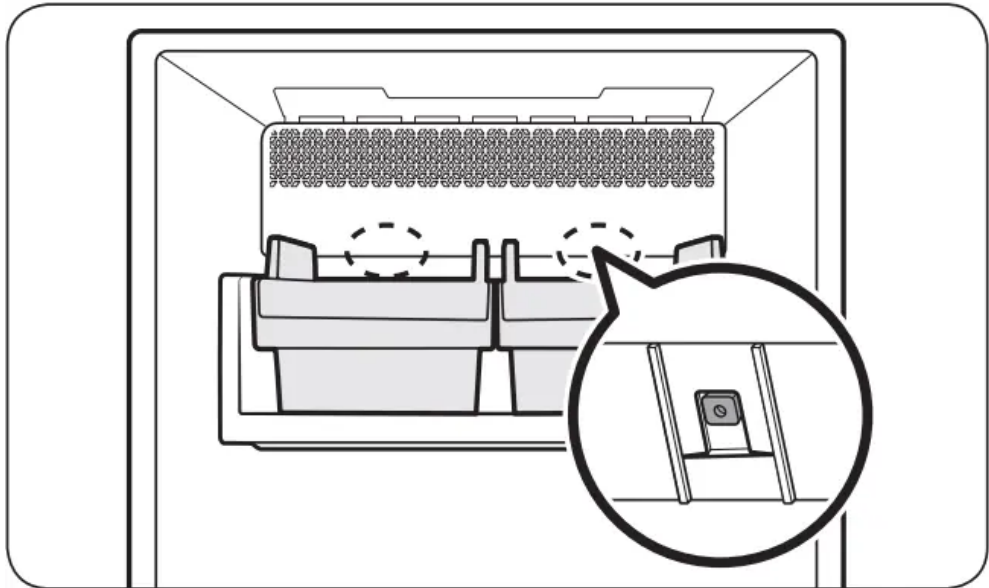

- The overall design and/or accessories may differ with the model.
- If ice does not dispense, first check the status of ice maker using the Test button on the bottom of the ice maker.
- Press the Test button on the bottom of the ice maker. You will hear a chime (ding-dong) when you press the button. You will hear another chime if the ice maker is operating properly.
- Ice accumulating on one side of the tray is normal. Arrange the ice evenly in the tray to store more ice.

## Maintenance

### Handling and care

#### Ice bucket (applicable models only)

If you do not dispense ice for an extended period, ice may form clumps inside the bucket. If this happens, remove and empty the ice bucket.

**AutoFill Pitcher (applicable models only)**

1. Grasp a handle groove of the lid, and then pull up to remove.
2. Grasp both sides of the infuser holder, and then lift to remove.
3. While slightly twisting the infuser, pull it out of the sealed mouth.
4. Clean the infuser with neutral agents and running water. Rinse and dry well.
5. Reassemble the AutoFill Pitcher in the reverse order of disassembly.

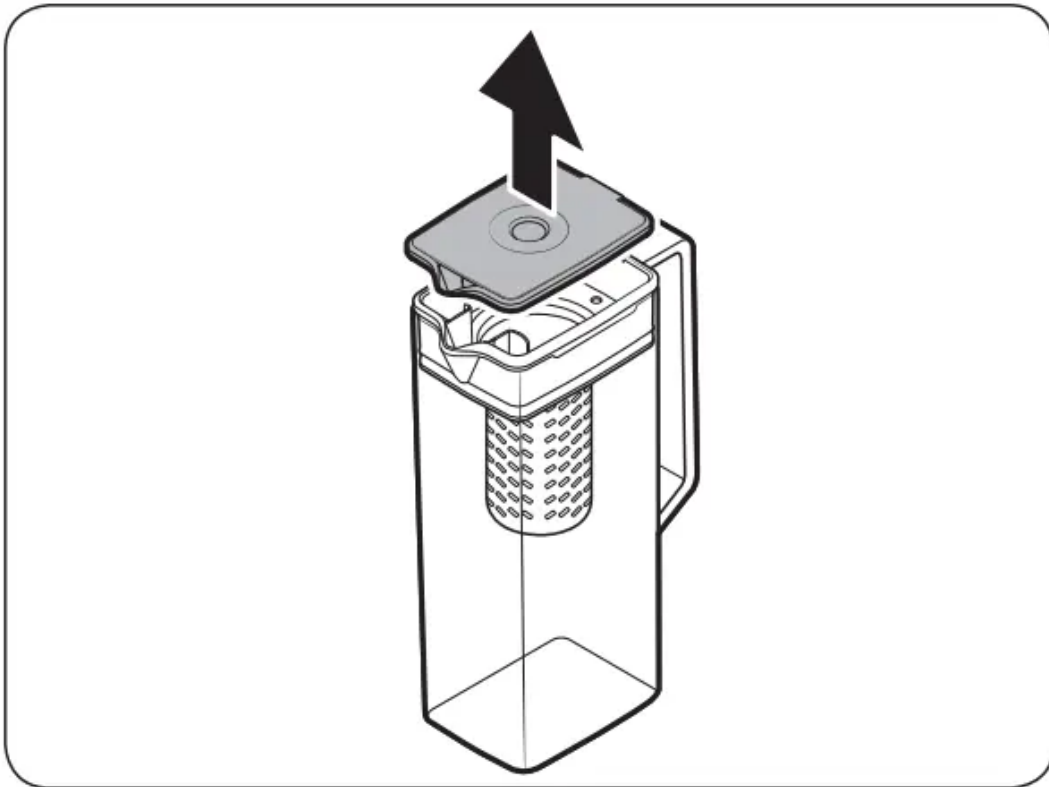

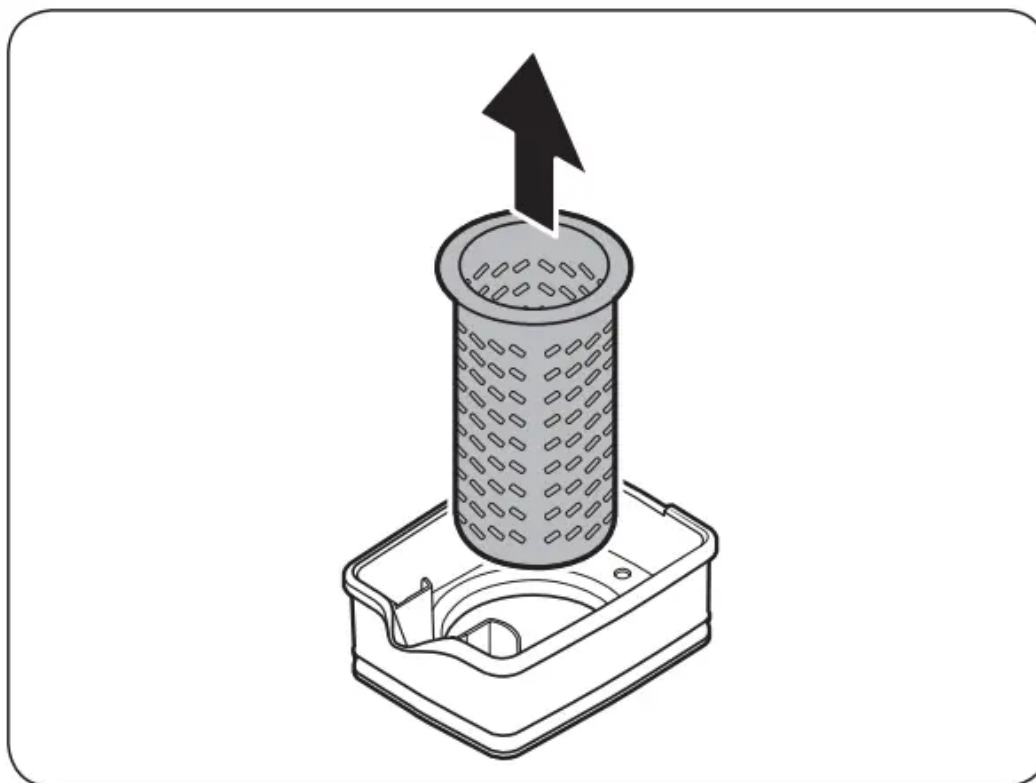
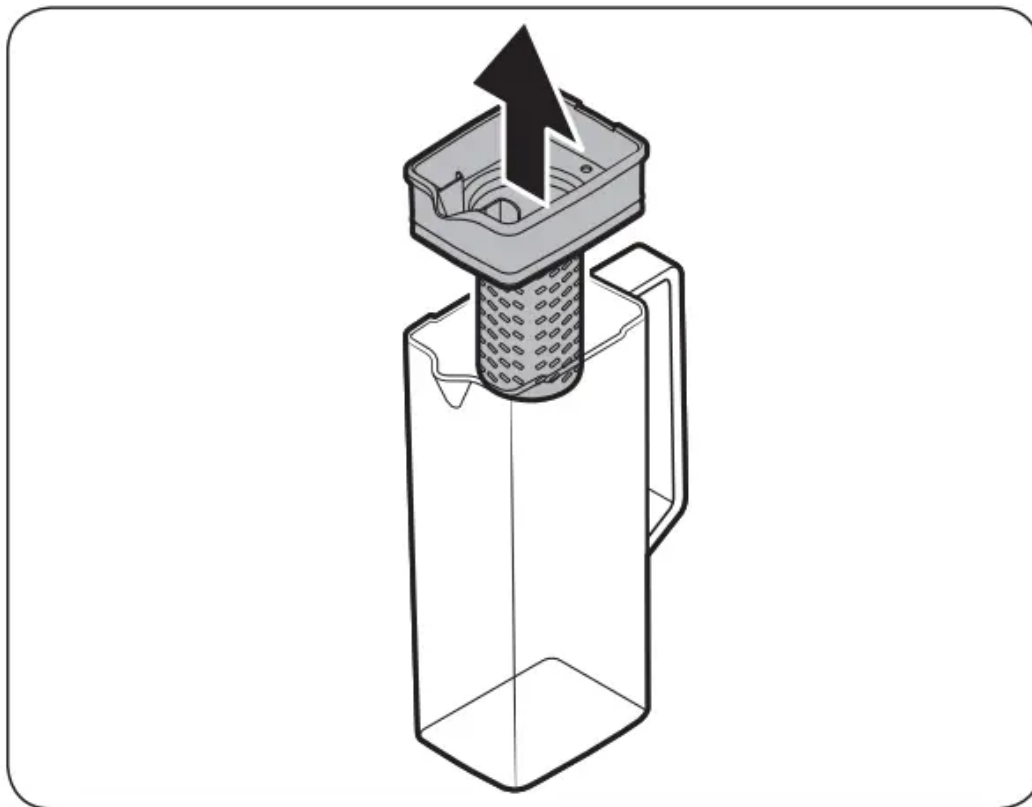

### Fridge shelves

The appearance of the shelves differs by model.

- To remove a shelf, fully open the corresponding door. Hold the front of the shelf, and then gently lift up and pull out.
- To reinsert, hold the shelf at an angle so the front is higher than the back, and then insert the top hook into the top shelf notch. Then, lower the shelf and insert the bottom shelf hook into the bottom shelf notch

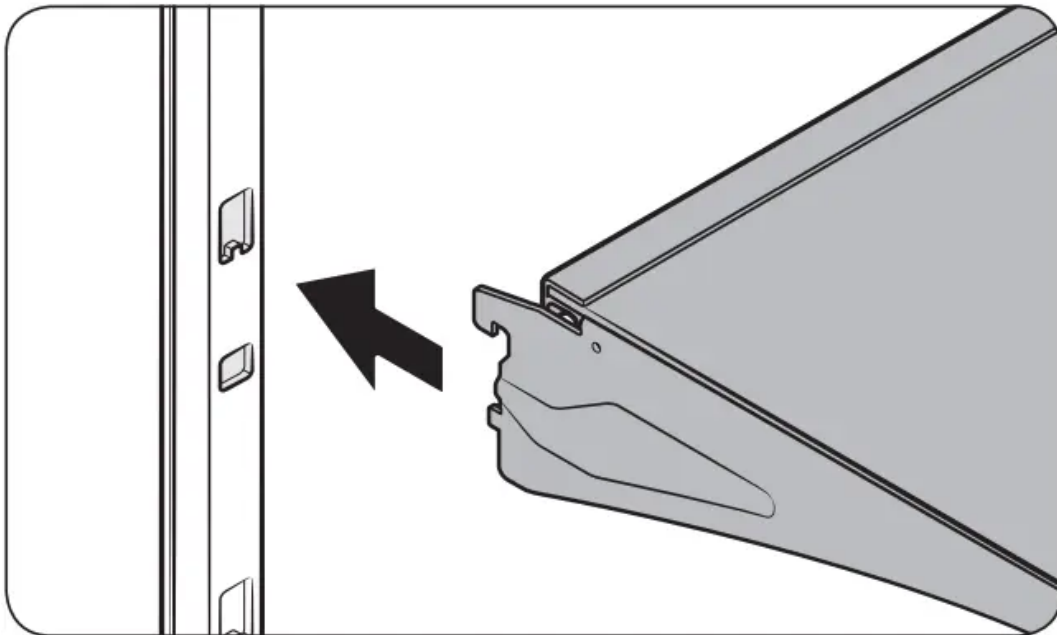
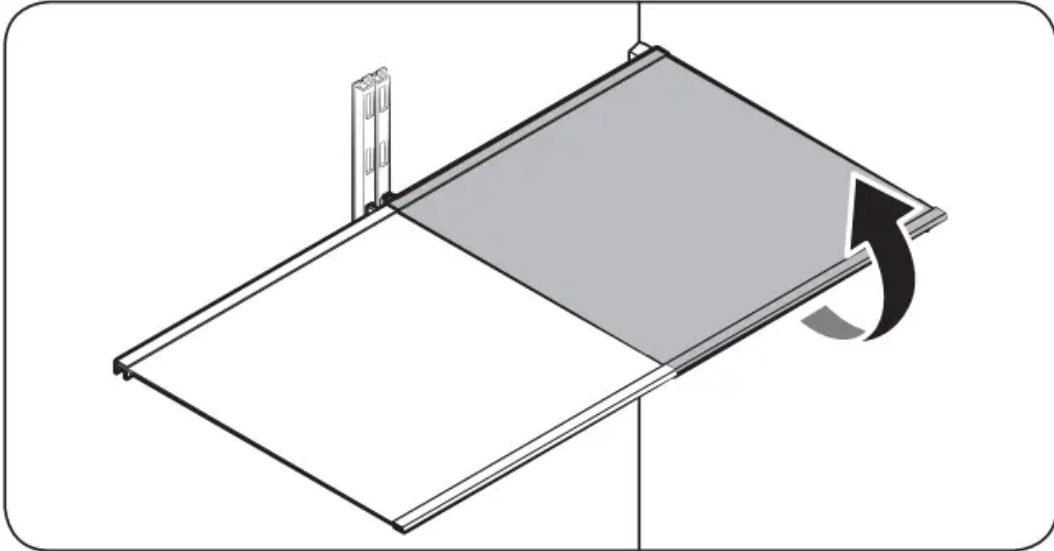

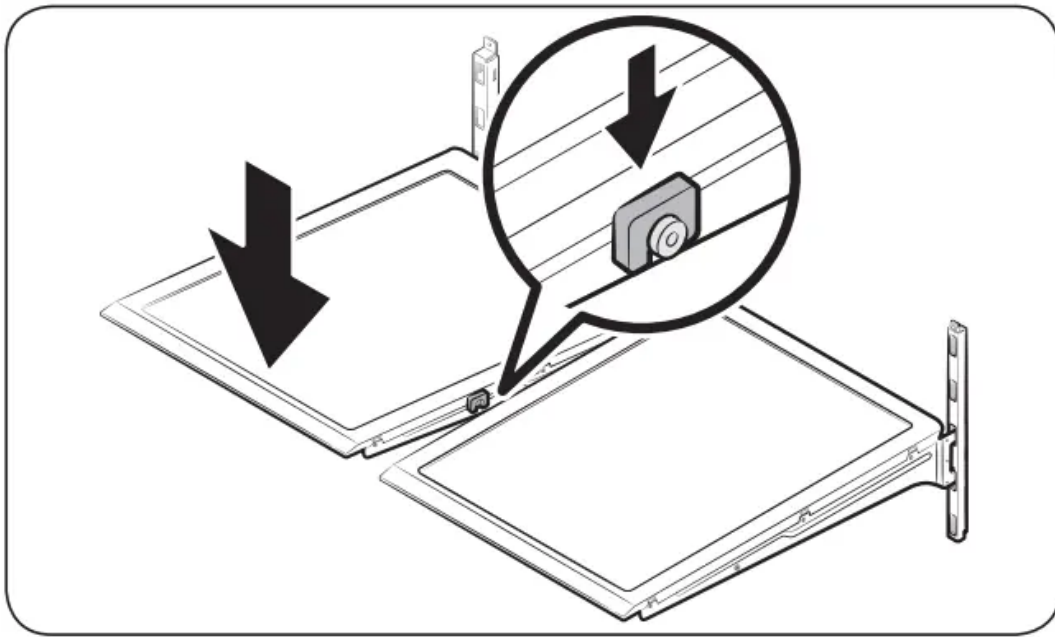

### Door bins

- To remove the door bin, hold the front sides of the bin, and then gently lift up to remove.
- To reinsert, insert the door bin slightly above its final location making sure that the back of the bin is against the door. Hold the rear of the door bin with both hands, and then press down so that it fits snugly.

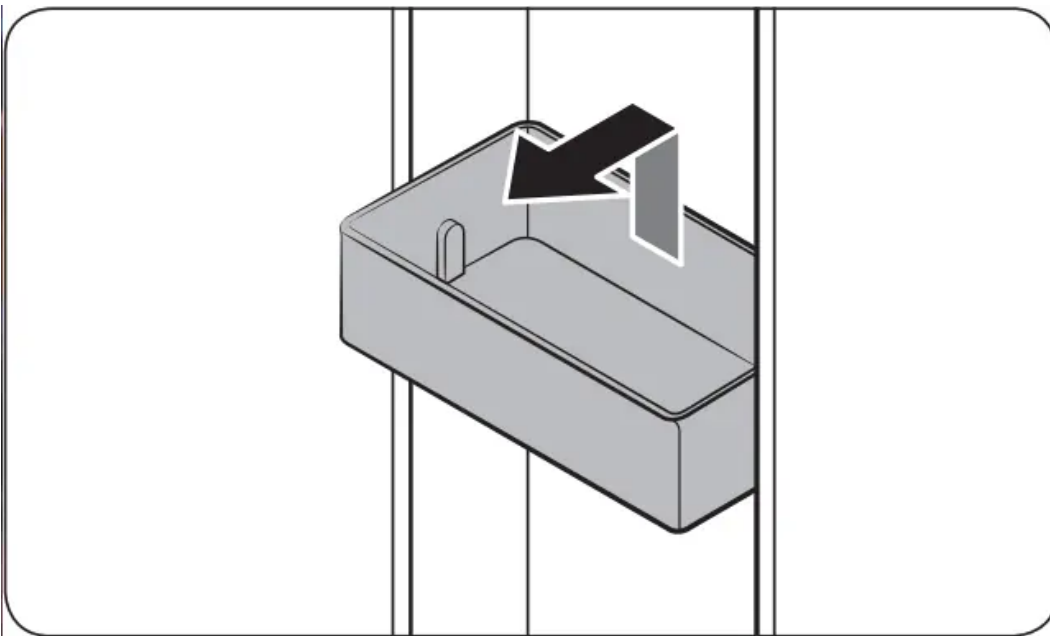

### Fridge drawers

Crisper+ / Flex Crisper

Gently lift up the front of the drawer and slide out.

- We recommend that you remove the door bins before removing the drawer. This is to prevent damage to the door bins.
- To reinsert, insert the drawer into the frame rails and then slide inward

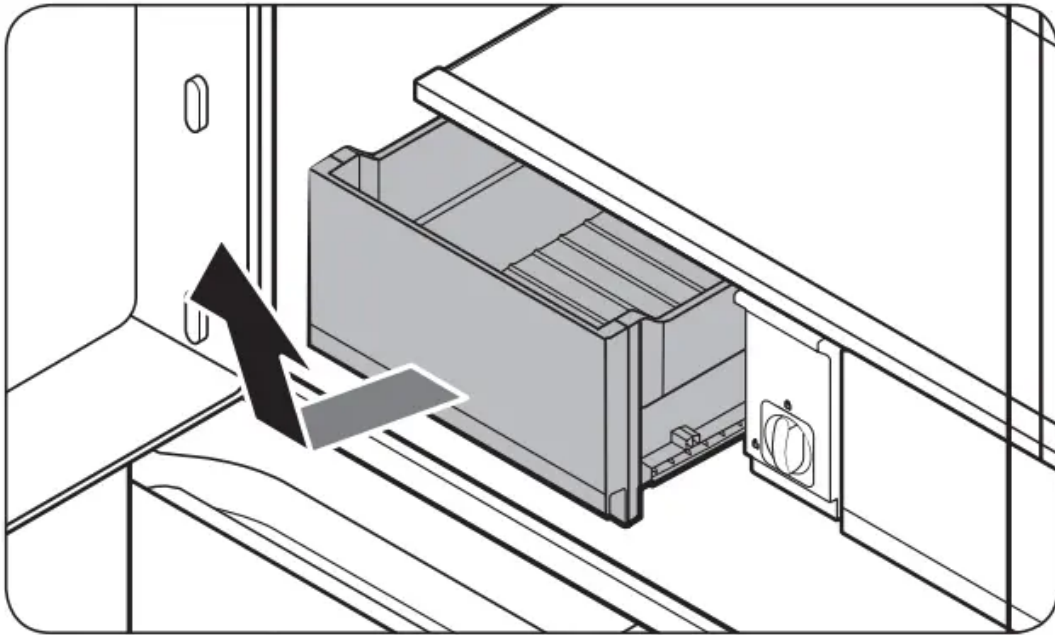

## Cleaning

### Interior and exterior

Regularly use a dry cloth to remove all foreign substances such as dust or water from the power plug terminals and contact points.

1. Unplug the power cord.
2. Use a moistened, soft, lint-free cloth or paper towel to clean the refrigerator's interior and exterior.
3. When done, use a dry cloth or paper towel to dry well.
4. Plug in the power cord.

### Dispenser nozzle (applicable models only)

1. Hold the end of the dispenser nozzle (A).
2. While turning the dispenser nozzle (A) left, pull it down to remove it from the dispenser.
3. Clean the dispenser nozzle thoroughly, and then assemble it back.

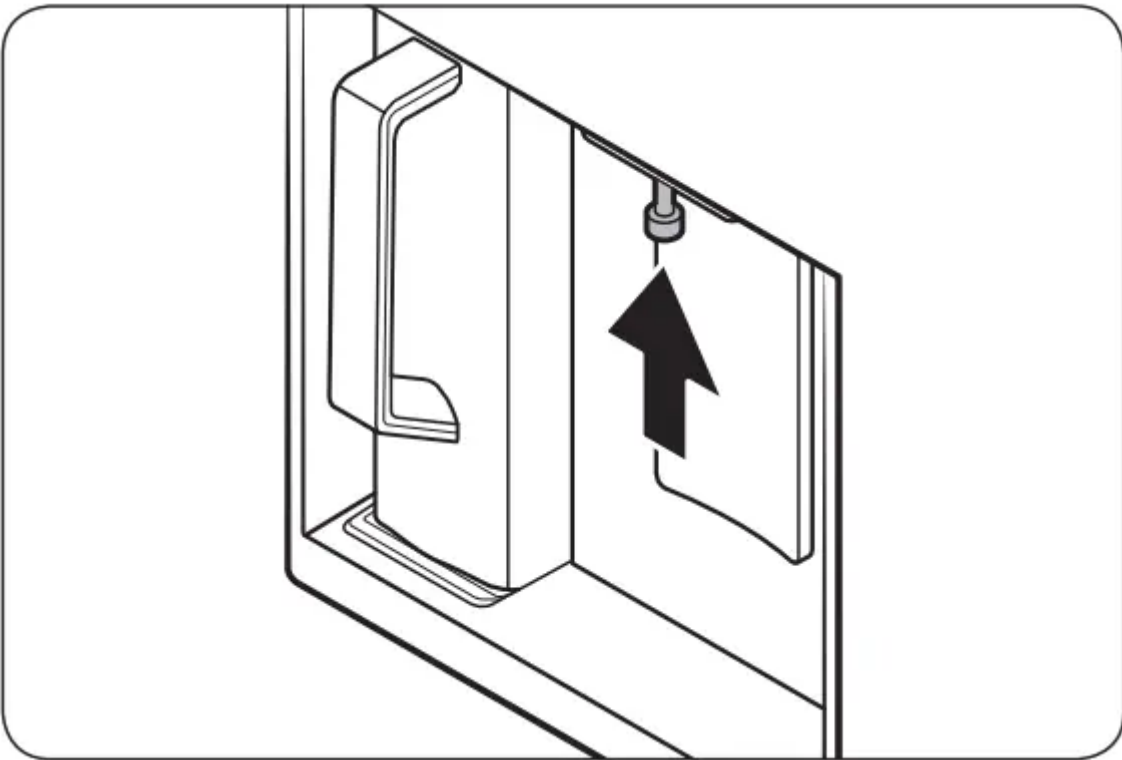
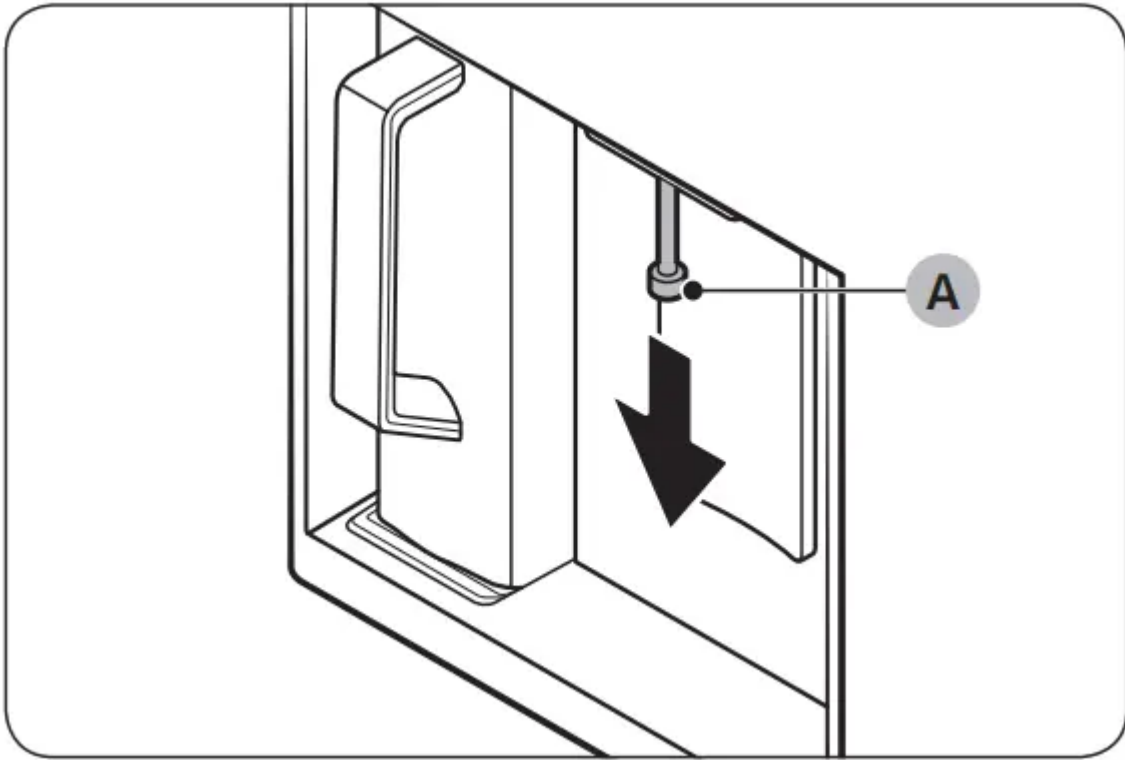

**Rubber seals**

If the rubber seals of a door become dirty, the door may not close properly and reducing refrigerator performance and efficiency. Use a mild detergent and damp cloth to clean the rubber seals. Then, dry well with a cloth.

**Rear panel**



To keep cords and exposed parts of the rear panel free of dirt, vacuum the panel once or twice a year.

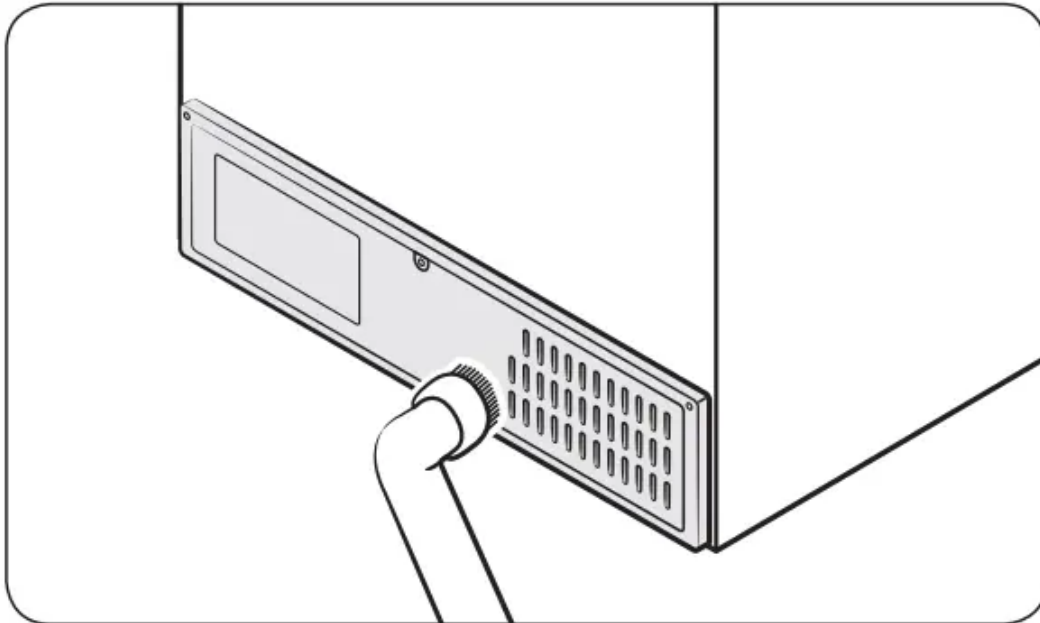

## Replacement

### Water filter

The “Replace water filter” message appears on the control panel to let you know it is time to replace the water filter. Before replacing the filter, make sure the water supply line is shut off.

1. Shut off the water supply line.
2. Open the filter cartridge cover.
3. Turn the knob of the filter cartridge counter clockwise 90 degrees (1/4 turn). The filter cartridge unlocks.
4. Pull out to remove the cartridge.
  - If the water filter is severely contaminated, the cartridge may not be easy to remove. If that is the case, use force to remove the cartridge.
  - To prevent water leaks from the filter opening, pull the cartridge straight out while removing it.
5. Insert a new filter cartridge. Use only Samsung-provided or approved filters.
6. Turn the cartridge knob clockwise to lock into place.
7. Close the filter cartridge cover.
8. On the control panel, go to More Options, and then run Filter Reset

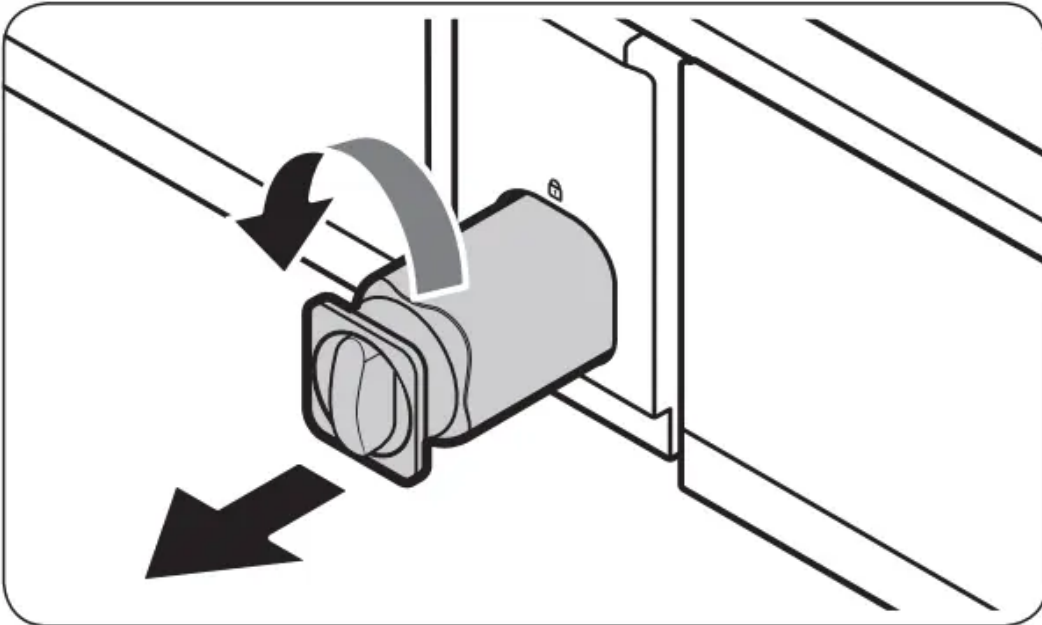
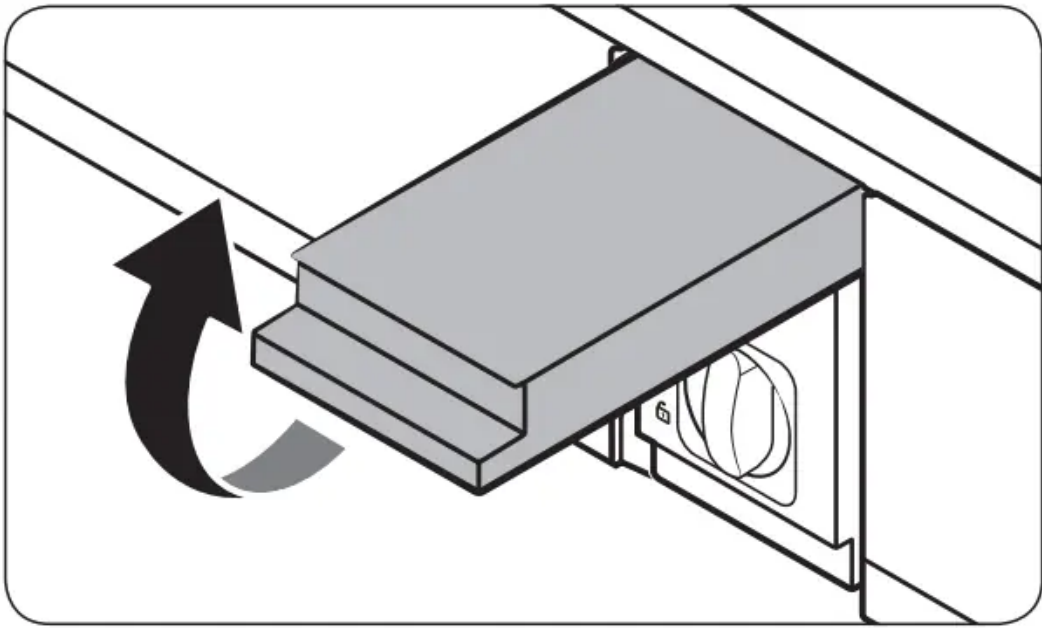

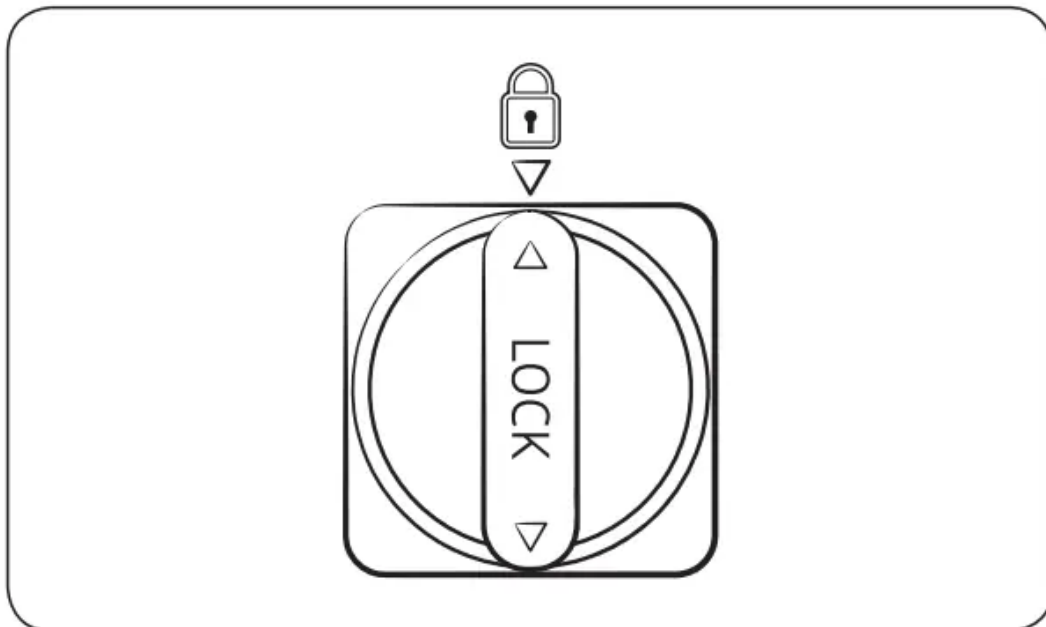
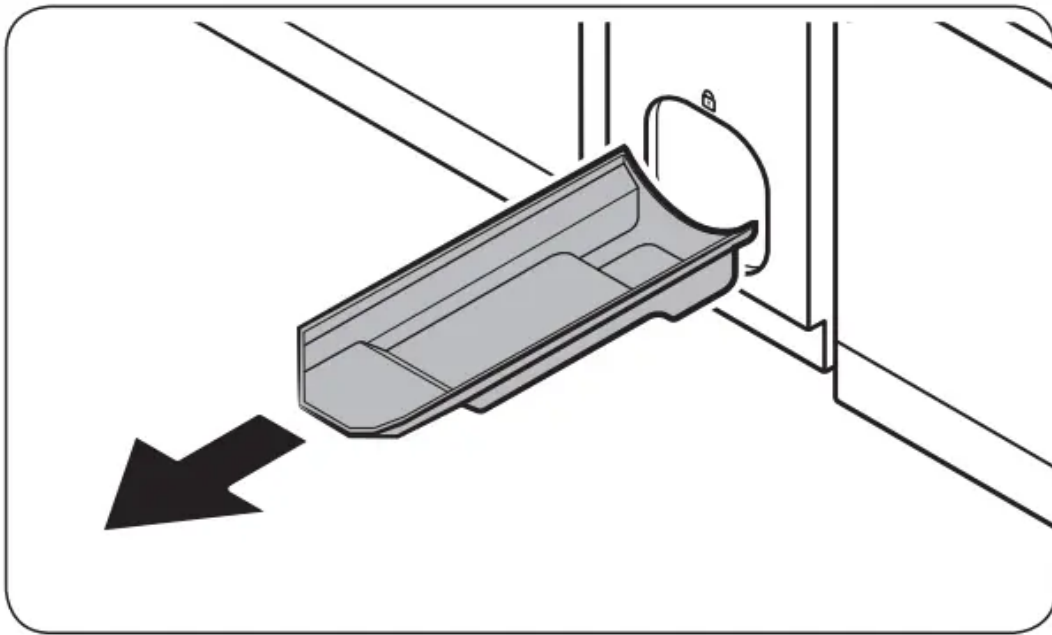

### **Reverse osmosis water filtration system**

The water pressure of the water supply system to a reverse osmosis water filtration system must be between 30-125 psi (206-861 kPa). The water pressure of the reverse osmosis water filtration system to the refrigerator's cold water line must be at least 30 psi (206 kPa). If the water pressure is below these specifications:

- Check if the sediment filter in the reverse osmosis system is blocked. Replace the filter if necessary.
- Refill the water tank in the reverse osmosis system with water.

- If your refrigerator has a water filter, it may further reduce the water pressure when used in conjunction with a reverse osmosis system. Remove the water filter.

For more information or servicing, contact a licensed plumbing professional.

### **Ordering a new filter**

To purchase a new water filter, contact a local Samsung service center or visit [www.samsungparts.com](http://www.samsungparts.com) on the web.

### **LED Lamps**

To replace the lamps of the refrigerator, contact a local Samsung service center.

### **Door panel (applicable models only)**

You can select the door panel you prefer for your BESPOKE refrigerator. Purchase the door panel at a Samsung retail store and an authorized installer will install the panel for you.

## **Troubleshooting**

### **General**

#### **Temperature**

Symptom	Possible causes	Solution
Fridge/freezer does not operate. Fridge/freezer temperature is warm.	Power cord is not plugged in properly.	Properly plug in the power cord.
	Temperature control is not set correctly.	Set the temperature lower.
	Refrigerator is located near a heat source or direct sunlight.	Keep the refrigerator away from direct sunlight or a heat source.
	Not enough clearance between refrigerator and nearby walls or cabinets.	Make sure there is a gap of at least 5 cm between the refrigerator back and sides and any nearby walls or cabinets
	Energy Saver mode is activated.	Deactivate Energy Saver mode.
	The refrigerator is overloaded. Food is blocking the refrigerator vents.	Do not overload the refrigerator. Do not allow food to block vents.
Fridge/freezer is over-cooling.	Temperature control is not set correctly.	Set the temperature higher
Interior wall is hot.	Refrigerator has heat-proof piping in the interior wall.	<p>To prevent condensation from forming, the refrigerator has heat-proof piping in the front corners. If the ambient temperature rises, this equipment may not work effectively. This is not a system failure</p> 

## Odors

Symptom	Possible causes	Solution
Refrigerator has odors	Spoiled food.	Clean the refrigerator and remove any spoiled food
	Food with strong odors.	Make sure strong smelling food is wrapped airtight.

## Frost

Symptom	Possible causes	Solution
Frost around the vents.	Food is blocking the vents.	Make sure no food blocks the refrigerator vents.
Frost on interior walls.	Door is not closed properly	Make sure food does not block the door. Clean the door gasket.
Fruits or vegetables are frozen.	Fruits or vegetables are stored in the FlexZone™.	Do not store most kinds of fruit or vegetables in the FlexZone™.

## Condensation

Symptom	Possible causes	Solution
Condensation forms on the interior walls.	• If door is left open, moisture enters the refrigerator	Remove the moisture and do not leave a door open for extended periods of time
	Food with high moisture content.	Make sure food is wrapped airtight.

## Water/ice (dispenser models only)

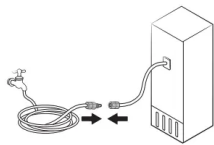
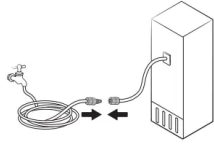
Symptom	Possible causes	Solution
Water flow is weaker than normal	Water pressure is too low	Make sure the water pressure is between 30 to 120 psi (206 to 827 kPa)
Ice maker makes a buzzing sound.	The ice maker function is activated, but the water supply to the refrigerator has not been connected.	Turn off the Ice Maker
Ice maker does not make ice.	Ice maker has just been installed.	You must wait for 12 hours for the refrigerator to make ice.
	Freezer temperature is too high.	Set the freezer temperature below -18 °C or -20 °C in warm ambient air
	Ice maker is off.	Turn on the ice maker.
Ice does not dispense.	Ice may jam if the ice dispenser is not used for a long time (approx. 3 weeks)	If you won't be using the refrigerator for a long time, empty the ice bucket and turn off the ice maker.
	Ice bucket is not properly inserted.	Make sure the ice bucket is properly inserted.
	Water line is not connected properly or water supply is not on.	Check the water installation conditions. 
Water does not dispense.	Water line is not connected properly or water supply is not on.	Check the water installation conditions. 

Dispenser panel Lock is activated.	Deactivate dispenser panel Lock.
A third-party water filter was installed.	<ul style="list-style-type: none"> <li>• Use only Samsung-provided or approved filters.</li> <li>• Unapproved filters may leak and damage the refrigerator.</li> </ul>
The "Replace water filter" message appears on the control panel.	Replace the water filter. Then, on the control panel, go to More Options, and then run Filter Reset.

### Do you hear abnormal sounds from the refrigerator?

Before calling for service, review the information below. If you still have questions about sounds your refrigerator is making, please call Samsung Customer Care at 1-800-SAMSUNG (726-7864). Note that you will be charged for any service visits related to normal operating sounds in which no defects were found.

#### These sounds are normal.

- When starting or ending an operation, the refrigerator may make sounds similar to a car engine igniting. As the operation stabilizes, the sounds will decrease.

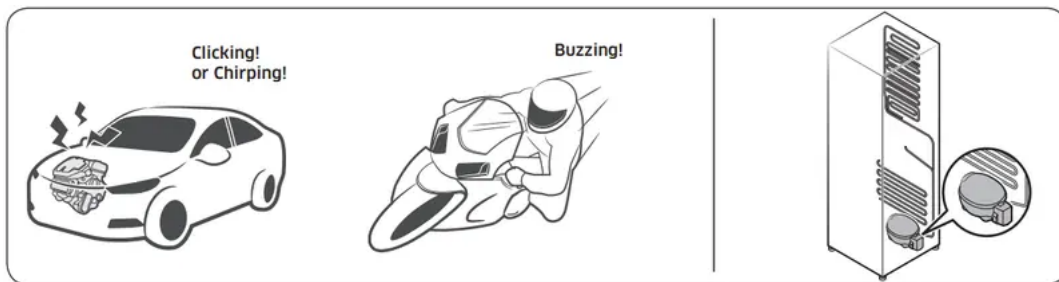

- While the fan is operating, these sounds may occur. When the refrigerator reaches the set temperature, the fan sound will stop.



- During a defrost cycle, water may drip on the defrost heater, causing sizzling sounds

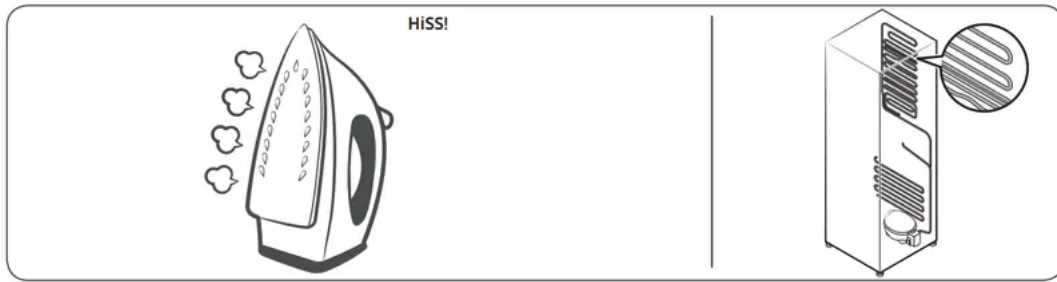

- As the refrigerator cools or freezes, refrigerant gas moves through sealed pipes, causing bubbling sounds.

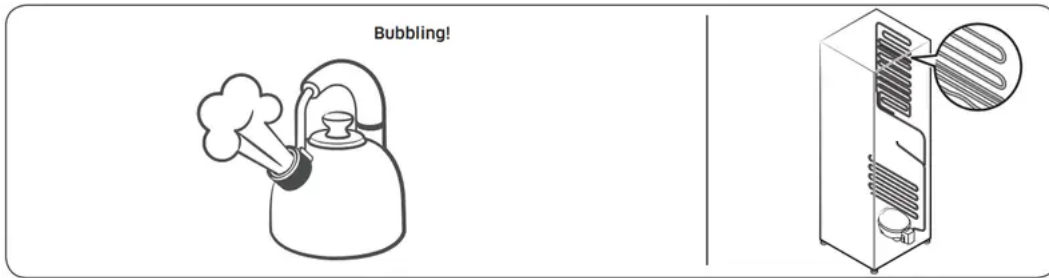

- As the refrigerator temperature increases or decreases, plastic parts contract and expand, creating knocking noises. These noises occur during the defrosting cycle or when electronic parts are working.

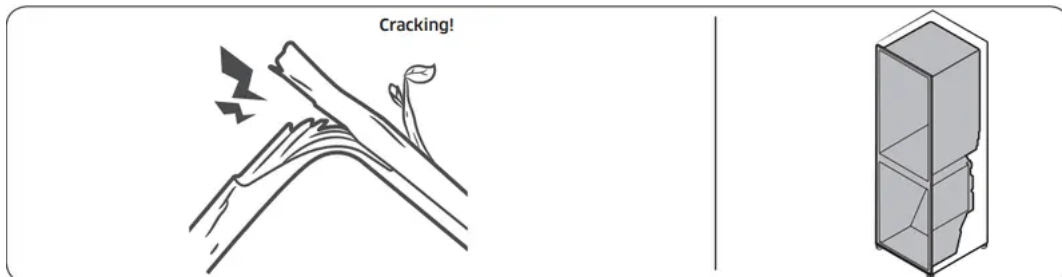

- For ice maker models: When the water valve opens to fill the ice maker, you may hear a buzzing sound.
- Due to pressure equalizing when you open and close the refrigerator door, you may hear a whooshing sound.

## SmartThings

<b>Symptom</b>	<b>Action</b>
Could not find “SmartThings” in the app market.	The supporting software version of the SmartThings app is subject to change according to the OS supporting policy the manufacturer provides. In addition, as for the SmartThings app or the functions that the app supports, the new application update policy on the existing OS version can be suspended due to usability or security reasons.
The SmartThings app fails to operate.	<ul style="list-style-type: none"> <li>• The SmartThings app is available for applicable models only.</li> <li>• The old Samsung Smart Refrigerator app cannot connect with Samsung Smart Home models.</li> </ul>
The SmartThings app is installed but is not connected to my refrigerator.	<ul style="list-style-type: none"> <li>• You must log into your Samsung account to use the app.</li> <li>• Make sure that your router is operating normally.</li> <li>• If the Wi-Fi icon on the refrigerator’s display is off, this indicates that no network connection has been established yet. In this case, use the SmartThings app to connect and register your refrigerator to the access point (AP) of your house.</li> </ul>
Could not log into the app.	<ul style="list-style-type: none"> <li>• You must log into your Samsung account to use the app.</li> <li>• If you don’t have a Samsung account, follow the app’s onscreen instructions to create one.</li> </ul>
An error message appears when I try to register my refrigerator.	Easy Connection may fail due to the distance from your access point (AP) or electrical interference from the surrounding environment. Wait a moment and try again.
The SmartThings app is successfully connected to my refrigerator but does not run.	<ul style="list-style-type: none"> <li>• Exit and restart the SmartThings app or disconnect and reconnect the router.</li> <li>• Unplug the power cord of the refrigerator, and then plug it in again after 1 minute</li> </ul>

**Smart Grid (applicable models only)**



Symptom	Action
<p>What Do I Need to use the Energy Management and Smart Grid functions?</p>	<p>To use the Smart Grid (Demand Response) and Energy Management functions on your refrigerator, you need the following: Devices</p> <ul style="list-style-type: none"> <li>• A wireless access point (router)</li> <li>• A Samsung Energy Management-supported refrigerator</li> <li>• A smartphone</li> </ul> <p>Registration</p> <ul style="list-style-type: none"> <li>• Connect your refrigerator to your home Wi-Fi network.</li> <li>• Register for the EMS service with your electric company. Your electric company must have an EMS (Energy Management System) supporting SEP (Smart Energy profile).</li> </ul> <p>App</p> <ul style="list-style-type: none"> <li>• Download the SmartThings app from the Google Play Store, Apple App Store, or Samsung Galaxy Apps.</li> <li>• Install and run the SmartThings app on your smartphone.</li> </ul>
<p>Why isn't the Energy Management function working normally?</p>	<ul style="list-style-type: none"> <li>• Make sure that your home router is operating normally with proper Internet service and connection.</li> <li>• Make sure that the refrigerator is connected to the AP (router).</li> </ul> <p>Checkpoints</p> <ul style="list-style-type: none"> <li>• Connect your smartphone to the router (AP, Access Point), and then check if you can browse the Internet on the smartphone</li> </ul>
<p>Why isn't the Delay Defrost Capability working normally?</p>	<ul style="list-style-type: none"> <li>• Make sure that your home router is operating normally with proper Internet service and connection.</li> </ul>



**Warning**

This content is compiled from multiple sources and is provided for reference purposes only. It may not be complete or fully applicable to all situations. If you are unable to resolve your issue, please contact the product manufacturer or an authorized service provider for official support.

---

Document generated by [ManualsFile](#)