

## WHAT'S IN THE BOX

### CONTENTS

Confirm that the following parts are included:



Bose TV Speaker

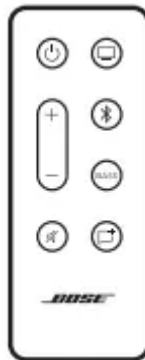

Bose TV Speaker remote (batteries provided)

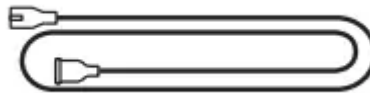

Power cord\*

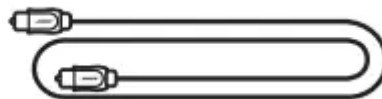

Optical cable

\* May ship with multiple power cords. Use the power cord for your region.

**NOTE:** If any part of the product is damaged, don't use it. Contact your authorized Bose dealer or Bose customer service.

### RECOMMENDATIONS

- Place the speaker outside of and away from metal cabinets, other audio/video components, and direct heat sources.

- Place the speaker directly below (preferred) or above your TV with the grille facing into the room.
- Place the speaker on its rubber feet on a stable and level surface. For proper support, both feet must be resting on the surface. Vibration can cause the speaker to move, particularly on smooth surfaces like marble, glass, or highly polished wood.
- If placing the speaker on a shelf or TV stand, position the front of the speaker as close as possible to the front edge of the shelf or stand for optimal sound quality.
- Keep the back side of the speaker at least 0.4 in (1 cm) from any other surface. Blocking the ports on this side affects sound quality.
- Make sure there is an AC (mains) outlet nearby.
- To avoid wireless interference, keep other wireless equipment 1 – 3 ft (0.3 – 0.9 m) away from the speaker.
- For best sound quality, don't place the speaker in an enclosed cabinet or diagonally in a corner.
- Don't place any objects on top of the speaker.

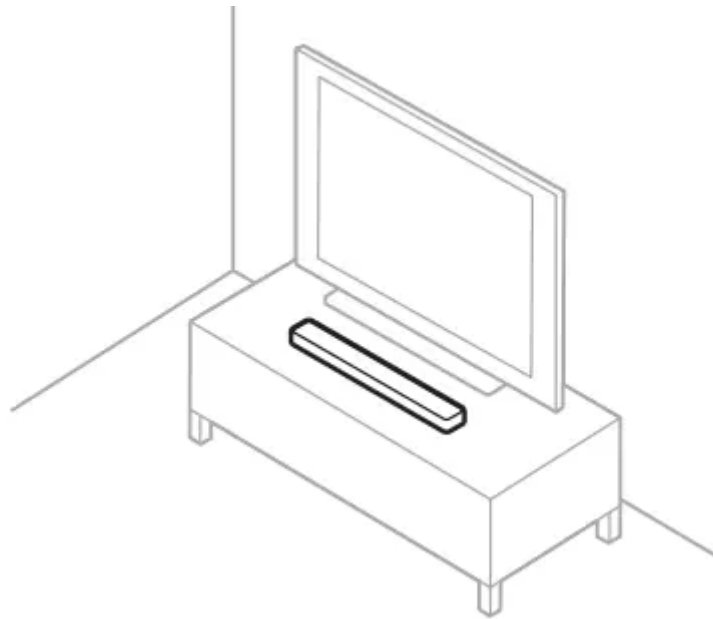

**CAUTION:** Do NOT place the speaker on its front, back, or top when in use.

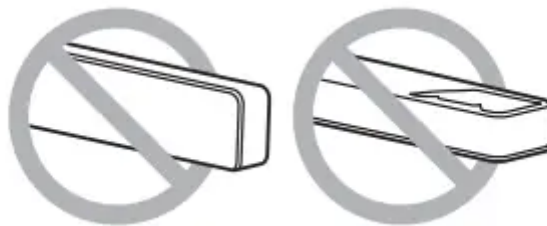

## WALL MOUNT THE SPEAKER

You can mount the speaker on a wall. To purchase the Bose Soundbar Wall Bracket, contact your authorized Bose dealer.

**CAUTION:** Do NOT use any other hardware to mount the speaker.

### Adjust audio for wall mounting

On the remote, press and hold the Dialogue mode button  for 5 seconds until the TV light on the speaker blinks amber.



## SET UP THE SPEAKER

### CABLE OPTIONS

Connect your TV to the speaker using one of the two cable options.

- Option 1: Optical
- Option 2: HDMI ARC (not provided)

### NOTES:

- Using your TV's HDMI ARC or Audio Return Channel port allows you to use your TV remote to control the power, volume, and mute functions of the speaker.
  - If your TV does not have either an Optical or HDMI port see "Alternate Setup" on page 33.
1. On the back of your TV, locate the Audio OUT (optical) or HDMI IN port panels.

**NOTE:** Your TV's port panel may not appear as shown. Look for the shape of the port.

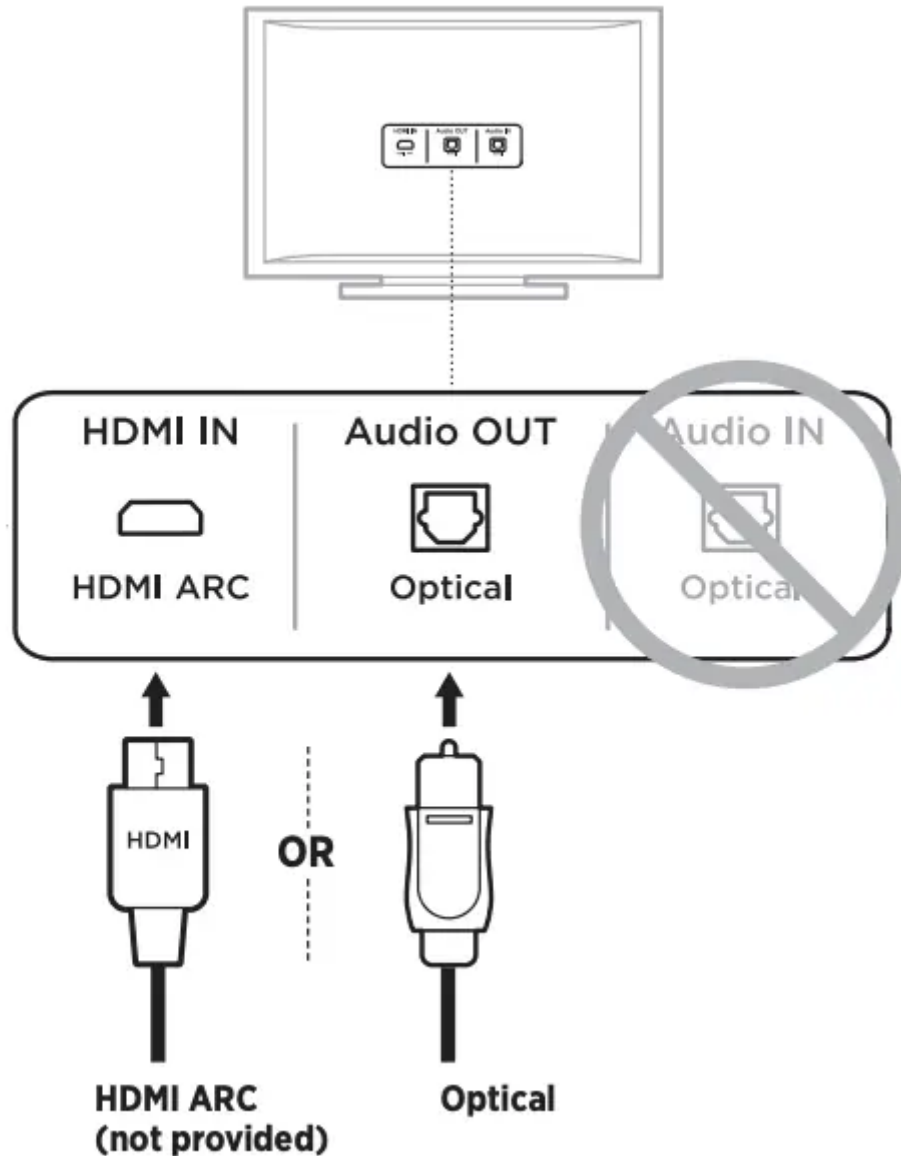

## CONNECT THE SPEAKER TO YOUR TV

### Option 1: Optical

1. Remove the protective cap from both ends of the optical cable.

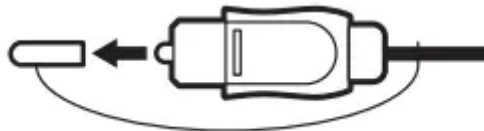

**CAUTION:** Make sure you have removed the protective cap from both ends of the optical cable. Inserting the plug with the cap on or in the wrong orientation can damage the plug and/or the port.

2. Align one end of the plug with your TV's Optical OUT port and insert the plug carefully.
3. Hold the plug at the end of the optical cable with the Bose logo facing down.

4. Align the plug with the speaker's OPTICAL IN port and insert the plug carefully.

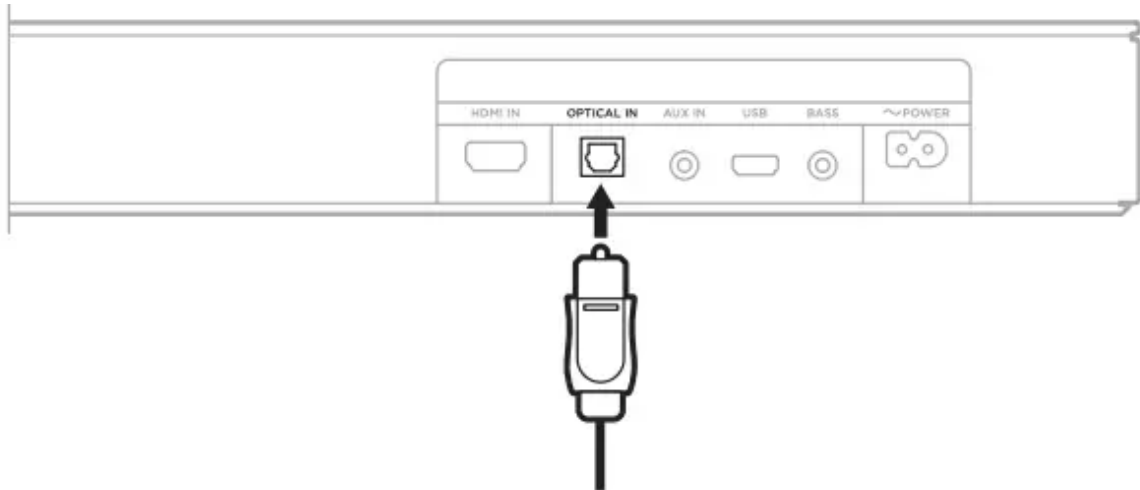

**NOTE:** The port has a hinged door that swings inward when inserting the plug.

5. Firmly push the plug into the port until you hear or feel a click.



### Option 2: HDMI ARC (not provided)

1. Insert one end of the HDMI cable into your TV's HDMI ARC port.

**NOTE:** If you don't connect to your TV's HDMI ARC or Audio Return Channel port, you won't hear audio from the speaker. If your TV doesn't have an HDMI ARC port, connect your speaker using the provided optical cable (see page 15).

2. Insert the other end of the cable into the HDMI IN port on the speaker.

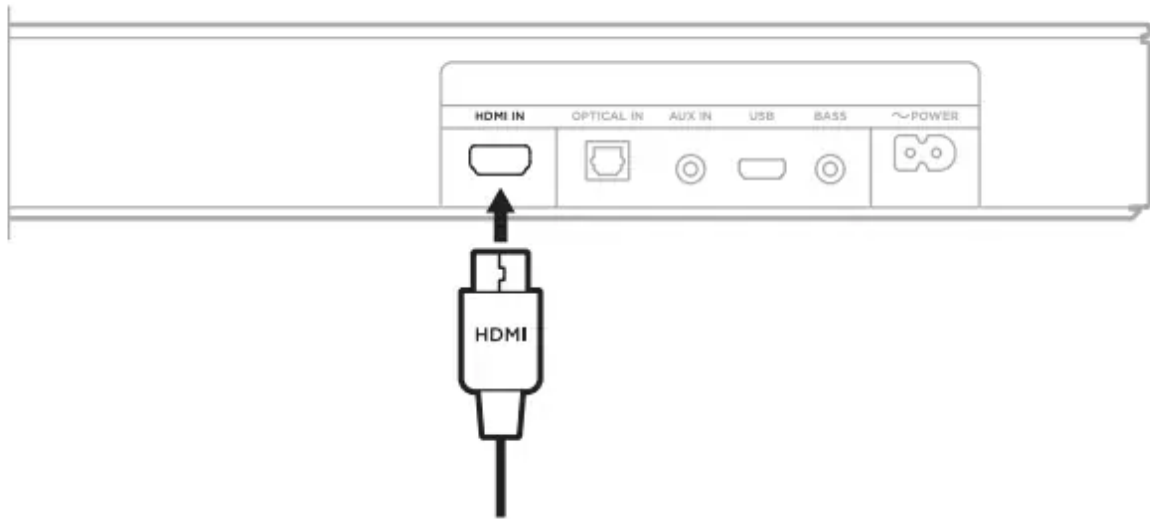

## CONNECT THE SPEAKER TO POWER

1. Connect the power cord to the  POWER port on the back of the speaker.
2. Plug the other end of the power cord into an AC (mains) power outlet.

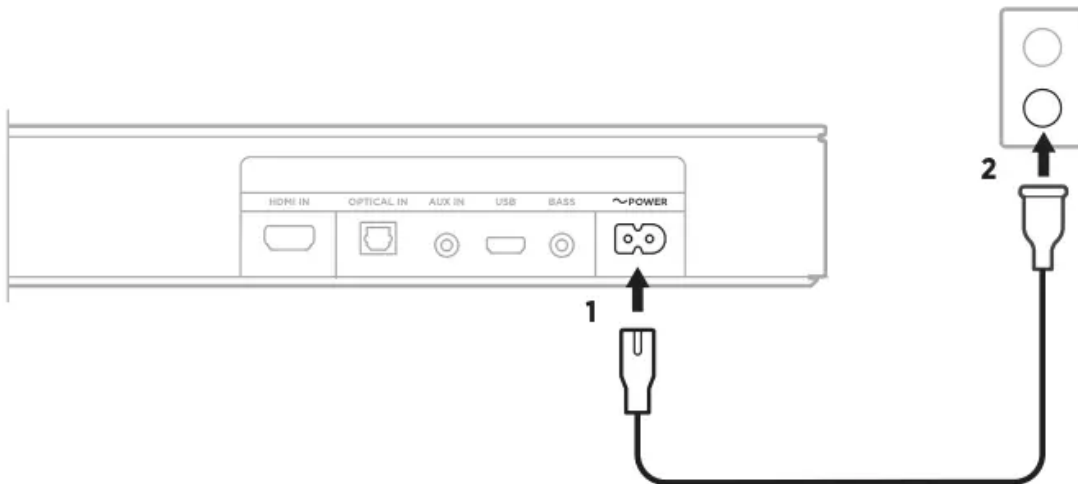

The speaker powers on, and you hear a tone.

## TURN OFF YOUR TV SPEAKERS

To avoid hearing distorted sound, turn off your TV speakers.

For more information, refer to your TV owner's guide.

**TIP:** The audio settings are usually found in the TV menu.

## CHECK FOR SOUND

1. Power on your TV.
2. If you are using a cable/satellite box or other secondary source:

- a. Power on this source.
  - b. Select the appropriate TV input.
3. Power on the speaker (see page 20). You hear sound coming from the speaker.
  4. Press A on the speaker remote. You don't hear sound coming from the TV speakers or speaker.

**NOTE:** If you don't hear sound coming from the speaker or do hear sound coming from your TV speakers, see page 37.

## SPEAKER CONTROLS

### REMOTE FUNCTIONS

Use the remote to control the speaker and Bluetooth connections.

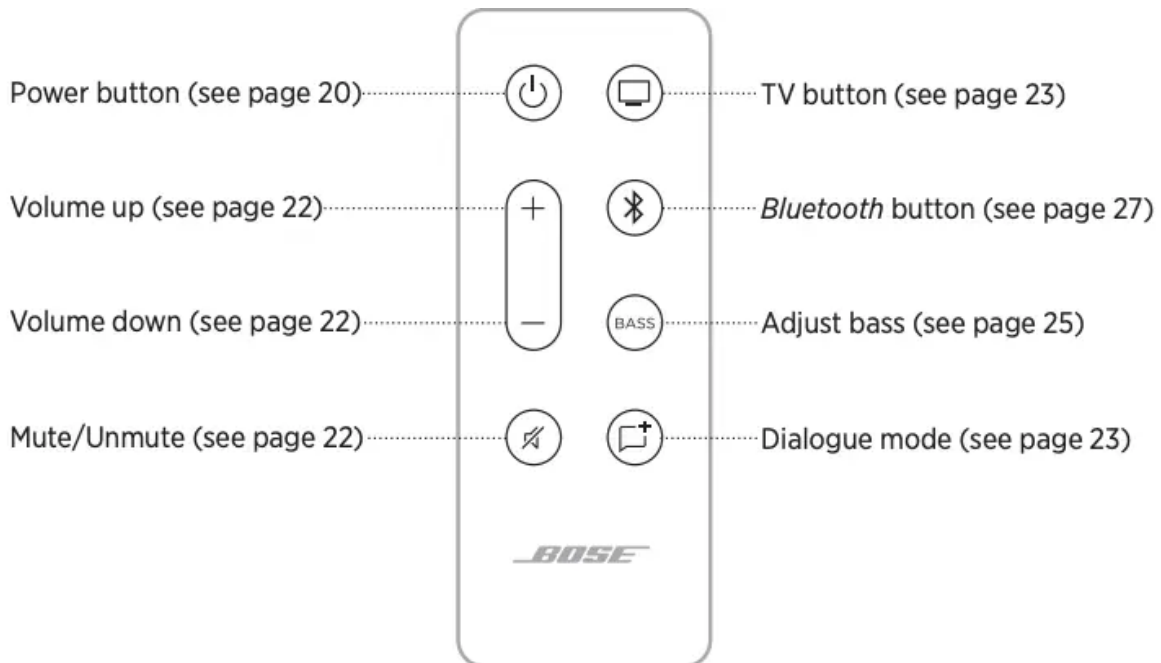

### Power

On the remote, press the Power button  to power the speaker on/off.



When powered on, the speaker defaults to the last active source.

**NOTES:**

- When you plug the speaker into an AC (mains) outlet, the speaker automatically powers on.
- The first time the speaker is powered on, the speaker defaults to the TV  source.

**Auto-wake**

You can set the speaker to power on whenever a sound signal is received.

On the remote press and hold the Power button  until you hear a tone and the TV and Bluetooth lights on the speaker blink amber 3 times to switch between auto-wake and default power settings.





**Volume**



FUNCTION	WHAT TO DO
<b>Volume up</b>	Press +. <b>NOTE:</b> To quickly increase the volume, press and hold +.
<b>Volume down</b>	Press -. <b>NOTE:</b> To quickly decrease the volume, press and hold -
<b>Mute/ Unmute</b>	Press  . When audio is muted, the light on the speaker of the current source (TV or Bluetooth) pulses white until audio resumes (see page 31). <b>TIP:</b> You can also press + to resume audio.

### Sources

You can control your TV and Bluetooth connections using your remote. To control a source, press the button (TV button  or Bluetooth button ) on the remote for the source you want to control.



## DIALOGUE MODE

Dialogue mode improves the clarity of dialogue and vocals in movies, TV programs, and podcasts by adjusting the audio balance of the system.

On the remote, press the Dialogue mode button  to switch between Dialogue mode and your default audio settings.



When Dialogue mode is enabled, the light for the current source glows green (see page 30).

**NOTE:** When you enable Dialogue mode, it stays enabled for your current source even if you switch to another source or turn off the speaker. To disable Dialogue mode for a source, press the

Dialogue mode button  again.

## ADJUST THE BASS

1. On the remote, press BASS.



On the speaker, the TV and Bluetooth lights blink white 3 times.

2. Adjust the bass by doing one of the following:

- Press Volume up + to increase the bass.
- Press Volume down - to decrease the bass.

The TV and Bluetooth lights on the speaker glow to show the current bass setting.

BASS SETTING	TV	Bluetooth
<b>2 (maximum)</b>	■	□
<b>1</b>	■	□
<b>0 (default)</b>	◁ □ ▷	◁ □ ▷
<b>-1</b>	□	■
<b>-2 (minimum)</b>	□	■

3. Press BASS. The speaker saves the current bass setting.

**NOTE:** For optimal sound quality for dialogue-only programs, such as news and talk shows, see “Dialogue mode” on page 24.

## RESET THE BASS

On the remote, press and hold BASS until the TV and Bluetooth lights on the speaker blink 3 times.



The bass settings reset to original factory settings.

Bluetooth wireless technology lets you stream music from mobile devices such as smartphones, tablets, and laptop computers. Before you can stream music from a device, you must connect your device to the speaker.

## BLUETOOTH CONNECTIONS

Bluetooth wireless technology lets you stream music from mobile devices such as smartphones, tablets, and laptop computers. Before you can stream music from a device, you must connect your device to the speaker.

### CONNECT A MOBILE DEVICE

1. On the remote, press the Bluetooth button 



The Bluetooth light on the speaker slowly pulses blue.

2. On your mobile device, turn on the Bluetooth feature.

**TIP:** The Bluetooth menu is usually found in the Settings menu.

3. Select your speaker from the device list.



Once connected, you hear a tone. The Bluetooth light glows solid white. Bose TV Speaker appears in the mobile device list.

## DISCONNECT A MOBILE DEVICE

Use your mobile device's Bluetooth menu to disconnect from the speaker.

**TIP:** You can also disable the Bluetooth feature on your mobile device to disconnect. Disabling the Bluetooth feature disconnects all other devices.

## RECONNECT A MOBILE DEVICE

On the remote, press the Bluetooth button .

The speaker tries to reconnect with the most recently-connected device. When connecting, the Bluetooth light on the speaker blinks white.

### NOTES:

- Make sure the Bluetooth feature is enabled on your mobile device.
- The device must be within 30 ft (9 m) of the speaker and powered on.

## CONNECT AN ADDITIONAL MOBILE DEVICE

You can store up to eight devices in the speaker device list, and the speaker can be actively connected to two devices at a time.

**NOTE:** You can play audio from only one device at a time.

1. On the remote, press and hold the Bluetooth button  until the Bluetooth light slowly pulses blue.



2. On your mobile device, select Bose TV Speaker from the device list.

**NOTE:** Make sure the Bluetooth feature is enabled on your mobile device.

### **CLEAR THE SPEAKER DEVICE LIST**

1. On the remote, press and hold  for 10 seconds until you hear a tone.
2. Delete Bose TV Speaker from the Bluetooth list on your device.

All devices are cleared, and the speaker is ready to connect (see page 27).

### **SPEAKER STATUS**

The LED lights located on the front of speaker show the speaker status.

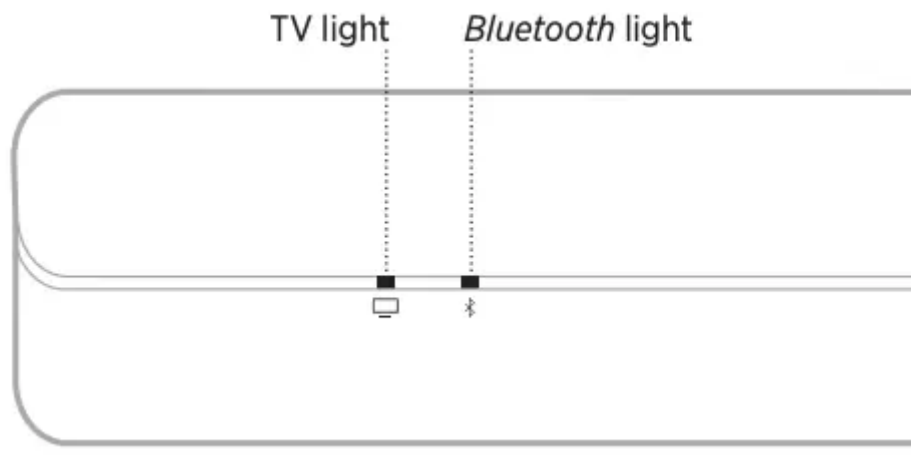

**NOTE:** The lights display the current sources highest priority status.

















## BLUETOOTH STATUS

Shows the Bluetooth connection status of mobile devices.

LIGHT ACTIVITY			SYSTEM STATE
<b>Bluetooth light slowly pulses blue</b>			Ready to connect
<b>Bluetooth light blinks white</b>			Connecting
<b>Bluetooth light glows white</b>			Connected









## MEDIA PLAYBACK AND VOLUME STATUS

Shows the speaker status when controlling media playback and volume.

LIGHT ACTIVITY			SYSTEM STATE
TV light is solid green			Dialogue mode enabled for TV
<i>Bluetooth</i> light is solid green			Dialogue mode enabled for <i>Bluetooth</i> -connected device
Both lights slowly pulse white			Power on/off
TV light blinks white			Changing volume for TV
<i>Bluetooth</i> light blinks white			Changing volume for <i>Bluetooth</i> -connected device
TV light slowly pulses white			Mute enabled for TV
<i>Bluetooth</i> light slowly pulses white			Mute enabled for <i>Bluetooth</i> -connected device

## UPDATE AND ERROR STATUS

Shows the status of software updates and error alerts.

LIGHT ACTIVITY			SYSTEM STATE
TV light pulses amber			Updating speaker
TV light blinks amber 3 times			Update complete
TV light blinks red			Speaker error - disconnect from power then reconnect. If error persists, contact Bose customer service

## ALTERNATE SETUP

### NO OPTICAL OR HDMI PORT ON YOUR TV

Some TVs don't have optical or HDMI ports. Use an alternate setup method to connect your TV to the speaker.

PROBLEM	WHAT TO DO
<b>TV only has an analog port</b>	Connect your TV using a 3.5 mm to RCA stereo cable (not provided). See "TV only has an analog port."
<b>TV only has a headphone port</b>	Connect your TV using a 3.5 mm stereo cable (not provided). See "TV only has a headphone port" on page 34.

### TV only has an analog port

If your TV only has analog ports (red and white), use a 3.5 mm to RCA stereo cable (not provided) to connect to the speaker.

1. If you haven't already, disconnect your TV from the speaker.
2. Insert the RCA analog cable into the Audio OUT RCA (red and white) ports on your TV.
3. Insert the stereo plug into the speaker's AUX IN connector.

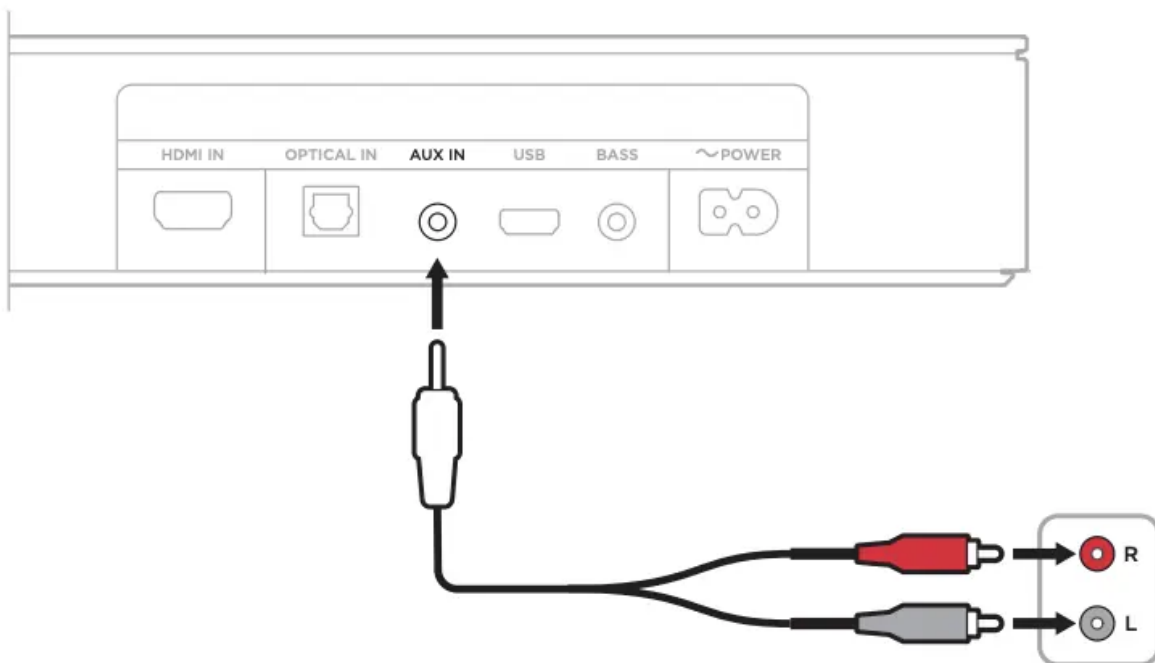

### TV only has a headphone port

If your TV only has a headphone port, use a 3.5 mm stereo cable (not provided) to connect the speaker.

1. Insert one end of a 3.5 mm cable into the TV headphones port.
2. Insert the other end of the cable into the AUX IN port on the speaker.

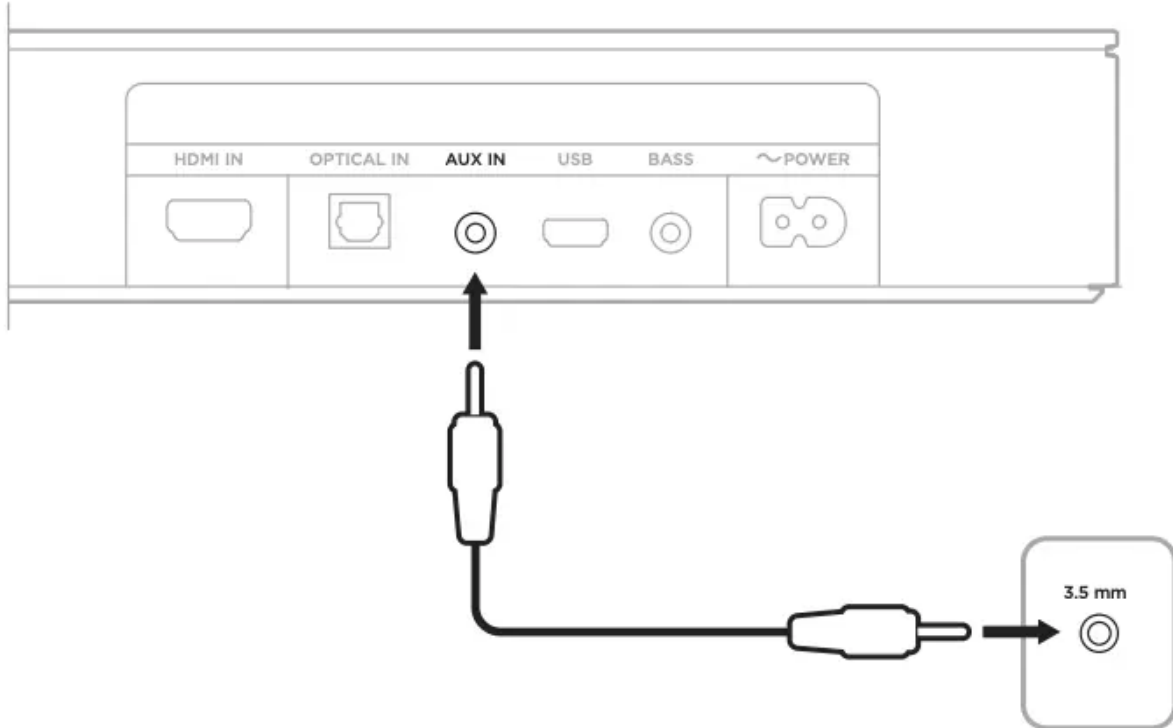

3. Make sure your TV speakers are on. Refer to your TV owner's guide for more information.
4. To ensure optimal volume control from your speaker:
  - a. Set your TV volume to 75 percent of maximum.
  - b. Set the speaker volume using the speaker remote

## CARE AND MAINTENANCE

### REPLACE THE REMOTE BATTERY

1. Using a coin, turn the battery compartment cover left (counter-clockwise), and remove the cover.

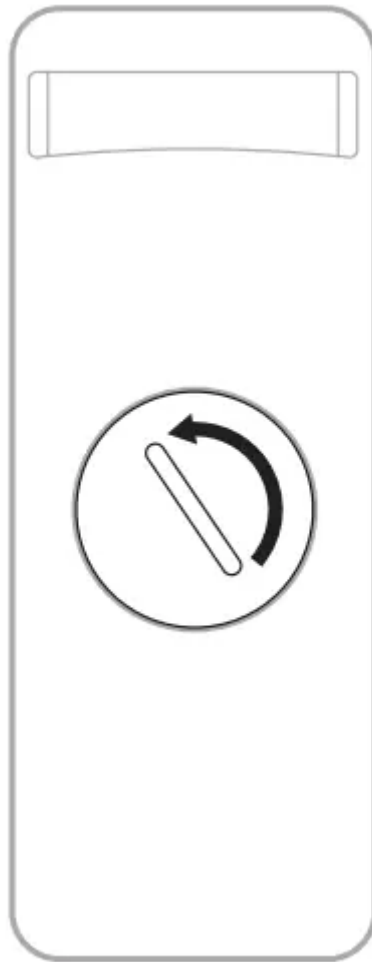

2. Insert the new battery flat side up, with the + symbol facing up.

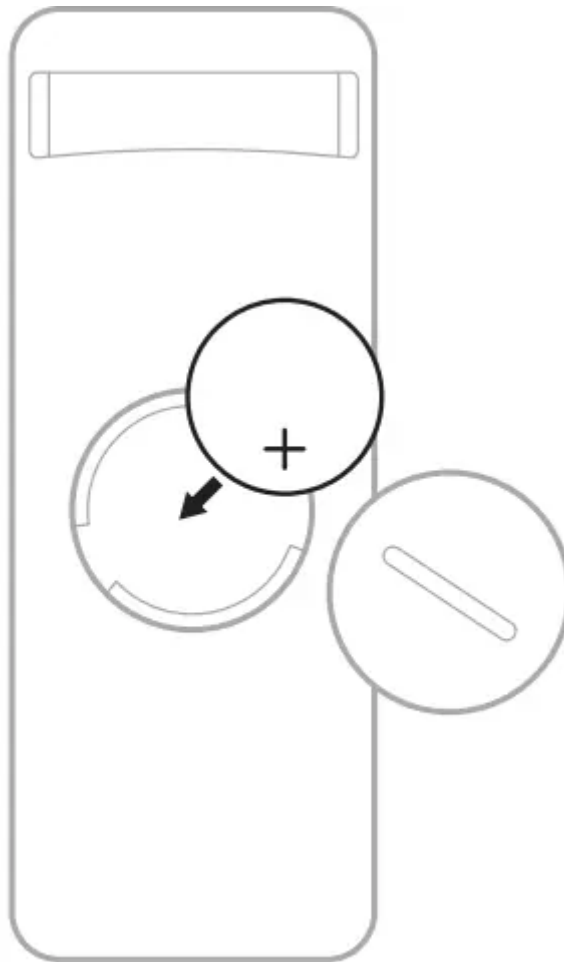

**NOTE:** Use only an agency approved (e.g., UL) CR2032 or DL2032 3-volt lithium battery.

3. Reset the cover and turn it right (clockwise) to lock in place.

## **CLEAN THE SPEAKER**

Clean the exterior of the speaker with a soft dry cloth.

### **CAUTIONS:**

- Do NOT allow liquids to spill onto the speaker or into any openings.
- Do NOT blow air into the speaker.
- Do NOT use a vacuum to clean the speaker.
- Do NOT use any sprays near the speaker.
- Do NOT use any solvents, chemicals, or cleaning solutions containing alcohol, ammonia, or abrasives.
- Do NOT allow objects to drop into any openings.

# TROUBLESHOOTING

## TRY THESE SOLUTIONS FIRST

If you experience problems with the speaker:

- Make sure the speaker is connected to a live AC (mains) outlet.
- Secure all cables and make sure all connections are correct.
- Check the status lights (see page 30).
- Move the speaker away 1 – 3 ft (0.3 – 0.9 m) from possible interference (wireless routers, cordless phones, televisions, microwaves, etc.).
- Place the speaker according to the placement guidelines (see page 12).

## OTHER SOLUTIONS

If you could not resolve your issue, see the table below to identify symptoms and solutions to common problems. If you are unable to resolve your issue, contact Bose customer service.

SYMPTOM	SOLUTION
<p><b>No HDMI ARC or optical port on your TV</b></p>	<p>Use an alternate setup method to connect your TV to the speaker (see page 33).</p>
<p><b>Speaker doesn't power on</b></p>	<p>Plug the power cord into a different AC (mains) outlet.</p> <p>Use the remote to power on the speaker (see page 20).</p> <p>Unplug the power cords for the speaker and optional bass module, wait 30 seconds, and plug them firmly into a live AC (mains) outlet.</p>
<p><b>Remote is inconsistent or doesn't work</b></p>	<p>Replace the battery (see page 35).</p> <p>Make sure the remote is within 20 ft (6 m) of the speaker.</p> <p>Make sure there are no obstructions between the remote and the speaker.</p> <p>Make sure you are in the correct source by pressing the volume button on the remote to see if the correct source light on the speaker flashes.</p>
<p><b>Intermittent or no audio from speaker</b></p>	<p>If the TV light or the Bluetooth light are pulsing, the speaker is muted. Press the Mute button A to unmute the speaker.</p> <p>Make sure your mobile device isn't muted.</p> <p>Increase the volume on the speaker (see page 22) or your mobile device.</p> <p>Switch to a different source (see page 23).</p> <p>Play audio from a different application or music service.</p> <p>Restart your mobile device.</p> <p>Make sure you're using a compatible Bluetooth mobile device.</p> <p>You can't connect Bluetooth headphones to the speaker.</p> <p>Make sure that the speaker's HDMI cable is inserted into a port on your TV labeled HDMI ARC (Audio Return Channel), not a standard HDMI port. If your TV doesn't have an HDMI ARC port, connect the speaker using an optical cable (see page 14).</p> <p>If the speaker is connected to your TV's HDMI ARC port, make sure that Consumer Electronics Control (CEC) is enabled in your TV system menu. Your TV may refer to CEC by a different name. Refer to your TV owner's guide.</p>



	<p>Power off your TV, disconnect the speaker's HDMI cable from your TV's HDMI ARC port and reconnect it. Power on your TV.</p> <p>Insert the optical cable into a port on your TV labeled Output or OUT, not Input or IN.</p> <p>Unplug the power cords for the speaker and optional bass module, wait 30 seconds, and plug them firmly into a live AC (mains) outlet.</p>
<p><b>No audio from bass module</b></p>	<p>Make sure your bass module is connected to power.</p> <p>Make sure the bass module is connected to the BASS port on the back of the speaker.</p> <p>Make sure your bass module is compatible with the speaker see page 36).</p> <p>Adjust the bass level (see page 25).</p> <p>Switch to a different source (see page 23).</p>
<p><b>Sound is coming from TV speaker</b></p>	<p>Make sure that the speaker's HDMI cable is inserted into a port on your TV labeled ARC (Audio Return Channel). If your TV doesn't have an HDMI ARC port, connect to the speaker using the optical cable (see page 16).</p> <p>Turn off your TV speakers. Refer to your TV owner's guide.</p> <p>If the speaker is connected to your TV's HDMI ARC port, make sure that Consumer Electronics Control (CEC) is enabled in your TV system menu. Your TV may refer to CEC by a different name. Refer to your TV owner's guide.</p> <p>Disconnect the speaker's HDMI cable from your TV's HDMI ARC port and reconnect it.</p> <p>Decrease your TV volume to its lowest setting.</p> <p>Connect to the speaker using both an HDMI cable (see page 16) and the optical cable (see page 17).</p>
<p><b>Poor or distorted audio</b></p>	<p>Test different sources if available.</p> <p>Make sure that your TV can output surround sound audio. Refer to your TV owner's guide.</p> <p>If the audio is being played from another device, reduce the volume of that device.</p>



	<p>Power off your TV speakers. Refer to your TV owner's guide.</p> <p>If your speaker is wall mounted, adjust the audio using the remote (see page 13).</p>
<p><b>Speaker and source don't power on/off simultaneously</b></p>	<p>On the remote, press the source button for the source that is out of sync.</p> <p>Press the Power button  to power on/off the source.</p>
<p><b>Speaker doesn't connect with Bluetooth device</b></p>	<p>On your mobile device, turn the Bluetooth feature off and then on. Delete the speaker from the Bluetooth list. Connect again (see page 27).</p> <p>Connect a different mobile device (see page 29).</p> <p>Make sure you're using a compatible Bluetooth mobile device.</p> <p>You can't connect Bluetooth headphones to the speaker.</p> <p>Remove the speaker from your mobile device Bluetooth list. Connect again (see page 27).</p> <p>Clear the speaker device list (see page 29). Connect again (see page 27).</p>

**Warning**

This content is compiled from multiple sources and is provided for reference purposes only. It may not be complete or fully applicable to all situations. If you are unable to resolve your issue, please contact the product manufacturer or an authorized service provider for official support.

