

IMPORTANT SAFEGUARDS

The Elite Brand takes consumer safety very seriously. Products are designed and manufactured with our valued consumers' safety in mind. Additionally, we ask that you exercise a level of caution when using any electrical appliance by following all instructions and important safeguards.

READ ALL INSTRUCTIONS BEFORE USE AND SAVE FOR FUTURE REFERENCE.

WARNING: When using electrical appliances, basic safety precautions should always be followed as below:

1. This coffee maker is intended for indoor, household, non-commercial use for brewing coffee. Do not use the coffee maker for any other purpose.
2. Keep the coffee maker out of reach from children and pets. This coffee maker is not intended for use by children. Extra caution is necessary when using this product near children.
3. Never leave the coffee maker unattended while it is in use. Always unplug the coffee maker from the electrical outlet when storing.
4. Always operate the coffee maker on a flat, level, and stable surface.
5. Do not place the coffee maker in areas or on surfaces (for example: carpets) that may be damaged by water, heat, or moisture. We will not be liable for any water-related damage that occurs during the use of this product.
6. Do not set the hot carafe on a wet or cold surface as the temperature difference between the hot carafe and the colder surface may cause the carafe to break or crack.
7. Do not place the coffee maker or the carafe on or near gas or electric burners. Do not place the coffee maker or the carafe inside of, or on top of, a microwave oven or conventional oven.
8. Do not operate this product or any other electrical product in the presence of explosives and/or flammable fumes.
9. Use only product manufacturer's . attachments with this product; otherwise a risk of fire, electrical shock, or personal injury may result.
10. Keep the power cord and product away from heated surfaces.
11. Do not touch hot surfaces of this product. Always touch the product using the handle and knobs. Never move the coffee maker when it is in use or while it contains hot liquid. Allow the unit to cool completely before handling. Do not touch the glass portion of the carafe or other hot surfaces of the coffee maker.

12. Do not operate the coffee maker if it has a damaged power cord or plug. Do not operate the coffee maker if it shows signs of damage. This product has no user-serviceable parts. Do not attempt to repair this product yourself. Only qualified service personnel should perform any repairs.
13. Do not remove bottom cover of coffee maker, as there may be a risk of fire or electrical shock.
14. Do not immerse the power cord or plug in, or otherwise expose them to, water or other liquids, as an electrocution hazard may result.
15. Do not allow the power cord to hang over the edge of a table or counter where it may get tripped over or pulled.
16. To disconnect product from an electrical outlet, pull directly on the plug; do not pull on the power cord.
17. Keep the carafe lid on the carafe while brewing and serving coffee.
18. Never operate the coffee maker without the carafe in place on the warming plate and the carafe lid closed.
19. Do not clean the carafe with steel wool pads or other abrasive cleaners and materials.
20. Do not open the lid of the water reservoir or the filter basket while the coffee maker is brewing. Allow the filter basket to cool completely before removing it
21. The carafe is designed solely for use with this coffee maker. Do not use the carafe on a stovetop heating element or with other products.
22. Do not use the carafe if it has a loose, weakened handle or if it is cracked, chipped, or otherwise damaged.
23. This product is for indoor use only. Do not use this product outdoors, as an electrocution hazard exists.

SHORT CORD PURPOSE

Note: A short power cord is provided to reduce the risk of personal injury resulting from becoming entangled in or tripping over a long cord.

Longer power-supply cords or extension cords are available and may be used if care is exercised in their use.

If an extension cord is used: (1) the marked electrical rating of the extension cord should be at least as great as the electrical rating of the product; (2) the extension cord should be arranged so that it will not drape over the counter top or tabletop where it can unintentionally be pulled on or tripped over by children or pets.

POLARIZED PLUG

If this appliance is equipped with a polarized plug (one blade is wider than the other), please follow the below instructions:

To reduce the risk of electrical shock, this plug is intended to fit into a polarized outlet only one way. If you are unable to fit the plug into the electrical outlet, try reversing the plug.

If the plug still does not fit, contact a qualified electrician. Never use the plug with an extension cord unless the plug can be fully inserted into the extension cord. Do not alter the plug of the product or any extension cord being used with this product. Do not attempt to defeat the safety purpose of the polarized plug.

PARTS IDENTIFICATION

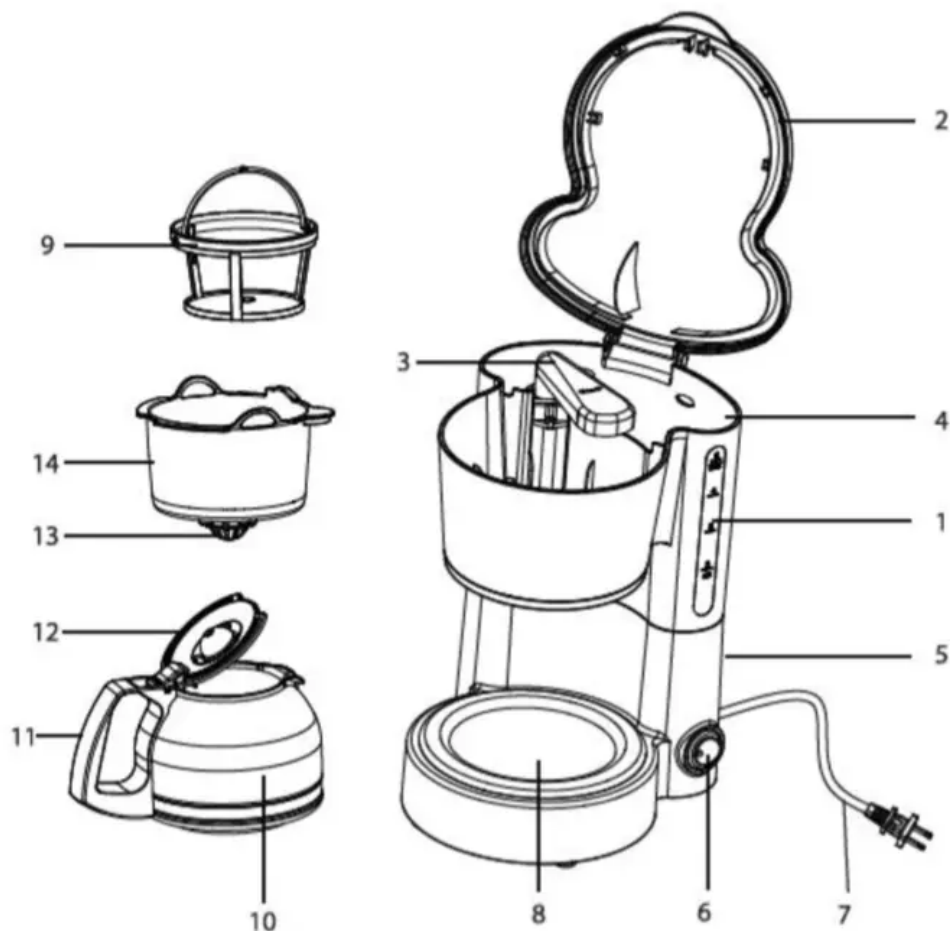

1. Water Level Indicator

2. Lid

3. Water Dispenser

4. Water Tank

5. Housing
6. On/Off Switch
7. Power Cord
8. Warming Plate
9. Permanent Filter
10. Glass Carafe
11. Grip Handle
12. Carafe Lid
13. Drip Stop Valve
14. Filter Basket

BEFORE FIRST USE

1. Unpack the appliance and all parts. Remove all packaging materials, including any stickers or labels.
2. Before the first use, please check if all the parts of the appliance are in good condition. If not, please contact the seller or manufacturer.
3. Clean the interior surface of the coffee maker with a damp cloth. Wipe dry with a soft cloth immediately. Do not use abrasive materials. Wipe down the exterior with a soft dry cloth.
4. NEVER IMMERSE APPLIANCE OR CORD IN WATER OR ANY OTHER LIQUID.
5. Position the coffee maker on a stable, dry, level, heat-resistant surface near an electrical outlet.
6. Unroll the electrical cord.
7. Operate the coffee maker on a separate outlet and circuit from other appliances to avoid overloading the circuit.
8. It is recommended to run the coffee maker for one cycle with just plain water and no coffee to clean the internal parts of the coffee maker.]

HOW TO USE

1. Make sure all parts are dry and that the unit is not plugged into an electrical outlet while filling with water and coffee grounds.
2. Open the lid (2) and take out the filter basket (14). Put your desired amount of ground coffee into the filter and distribute it evenly.

3. Reinstall the filter basket (14) and swing the water dispenser (3) clockwise so it's above the filter basket (14).
4. Pour in your desired amount of cold water into the water tank (4).
5. Put the carafe (10) with the lid closed onto the warming plate (8); the lid of the carafe pushes the drip stop valve (13) and opens the drip hole.
6. Plug the coffee maker into an electric outlet and switch to ON (6).
7. After a few minutes hot coffee drips into the carafe through the drip hole.

PAUSE 'N SERVE FEATURE:

During the middle of brewing process, you can pause the cycle by simply removing the carafe out of the coffee maker to sneak a cup of coffee. The drip stop valve will pause the brewing cycle and keep coffee from dripping into the carafe.

NOTE:

- Never leave the empty carafe on the warming plate when coffee maker is on. Otherwise the carafe is liable to crack.
- To stop brewing, turn the switch off at any time.
- Do not touch the warming plate as it is hot!
- Do not touch the lid during brewing.
- After brewing cycle is complete, wait a minimum of 10 minutes before taking out the filter basket to avoid any injury from hot steam.
- Make sure the filter is secured back in place before beginning to operate your coffeemaker.

AFTER USE:

1. When the last drop has dripped out of the filter, the carafe can be removed from the warming plate; the drip stop valve goes back automatically and closes the drip hole.
2. Put the carafe with the remaining coffee back on the warming plate to keep the coffee warm.
3. DO NOT OPEN THE LID WHILE THE COFFEE MAKER IS IN OPERATION AS THIS COULD LEAD TO PERSONAL INJURY.
4. Switch the appliance off and unplug from the electrical outlet.
5. The indicator light will turn off.
6. Clean the filter by removing the coffee filter and the remaining coffee grounds.

7. If more coffee is required, please switch off the appliance first. After cooling the appliance for 5 minutes, you can begin to brew again.

CLEANING & MAINTENANCE

Proper maintenance will ensure years of service of your appliance. Clean the appliance after every use following these steps:

1. Always remove the main plug from the wall socket and allow all parts to cool completely before cleaning the appliance.
2. Clean the housing and warming plate with a clean, damp cloth. Never immerse the unit in water or wash it directly in water.
3. Remove carafe, permanent filter and the filter basket from the coffee maker.
4. Only the carafe is dishwasher-safe. Wash the filter basket and permanent filter carefully using soap and warm water. Rinse and dry.
5. Use baking soda or mild detergent to remove stains on the carafe.
6. Ensure all parts are completely dry after washing and before use.
7. Store the coffee maker in a dry and clean place.

DESCALING:

1. When de-scaling, operate the appliance twice using a mixture of one part white vinegar and one part water to fill the water reservoir tank and let unit run as usual.
2. Run the unit twice more with only water to rinse away the remaining scale and vinegar.

NOTE:

- Always use care to prevent damaging the filter mesh.
- Make sure the filter is secured back in place before beginning to operate your coffeemaker.
- Do not dry inside of water tank with a cloth as lint may remain.

CAUTION:

Never immerse the entire coffee maker in water or any other liquid!

LIMITED WARRANTY* ONE (1) YEAR WARRANTY IS ONLY VALID WITH A DATED PROOF OF PURCHASE

PLEASE DO NOT RETURN TO STORE OF PURCHASE.

If you have any problems with this unit, contact Customer Service for support.

1. Your small kitchen appliance is warranted to the original purchaser to be free from any manufacturing defects under normal use and conditions for one (1) year, cord excluded. This Warranty applies only to the original purchaser of this product.
2. Retail stores/merchants selling this product do not have the right to alter, modify, or in any way revise the terms and conditions of the warranty.
3. If you use your appliance for household use and according to instructions, it should give you years of satisfactory service.
4. At its sole discretion, Maxi-Matic USA will either repair or replace the product found to be defective during the warranty period.
5. The repaired or replacement product will be in warranty for the remaining balance of the one-year warranty period and an additional one-month period.
6. Consumer's remorse is not an acceptable reason to return a product to our Service Center.
7. This limited warranty covers appliances purchased and used within the 50 U.S. states plus the District of Columbia and does NOT cover normal wear of parts or:

- Damages caused by unreasonable use, neglect, normal wear and tear, commercial use, improper assembly or installation of product.
- Damages caused in shipping.
- Damages caused by replacement or resetting of house fuses or circuit breakers.
- Defects other than manufacturing defects.
- Breakage caused by misuse, abuse, accident, alteration, lack of proper care and maintenance, or incorrect current or voltage.
- Lost or missing parts of the product. Parts will need to be purchased separately.
- Damages of parts that are not electrical; i.e. cracked or broken plastic/glass, scratched/dented inner pots.
- Damage from service or repair by unauthorized personnel.
- Extended warranties purchased via a separate company or reseller.
- Acts of nature such as fire, floods, hurricanes, tornadoes, etc.

8. This warranty does not apply to re-manufactured merchandise.

Maxi-Matic, USA shall not be liable for any incidental or consequential damages caused by the breach of any express or implied warranty. Apart from the extent prohibited by applicable law, any implied warranty of merchantability or fitness for a particular purpose is limited in time to the duration of the warranty.

*One Year Limited Warranty valid only in the 50 U.S. states plus the District of Columbia, excluding Puerto Rico and the Virgin Islands.

This warranty is effective only if the product is purchased and operated in the USA; product usage which is in violation of the written instructions provided with the unit will void this warranty. For international warranty, please contact the local distributor.

This warranty gives you special legal rights and you may also have other rights to which you are entitled which may vary by state, province, and/or jurisdiction.

**Any instruction or policy included in this manual may be subject to change at any time.

RETURN INSTRUCTIONS

RETURNS:

A. Any return of defective merchandise to the manufacturer must be processed accordingly by first contacting customer service (info@maxi-matic.com) to obtain an RA # (Return Authorization Number). We will not accept any returns of merchandise without an applicable RA #.

B. IMPORTANT RETURN INSTRUCTIONS. Your Warranty depends on your following these instructions if you are returning the unit to Maxi-Matic, USA:

1. Carefully pack the item in its original carton or other suitable box with sufficient cushioning to avoid damage in shipping.
2. Before packing your unit for return, be sure to enclose:
 - a) Your name, full address with zip code, daytime telephone number, and RA#,
 - b) A dated sales receipt or PROOF OF PURCHASE,
 - c) The model number of the unit and the problem you are having (Enclose in an envelope and tape directly to the unit before the box is sealed,) and
 - d) Any parts or accessories related to the problem.
3. Maxi-Matic, USA recommends that you ship the package via UPS ground service for tracking purposes. We cannot assume responsibility for lost or damaged products returned to us during incoming shipment. For your protection, always carefully package the product for shipment and insure it with the carrier. C.O.D shipments cannot be accepted.
4. All return shipping charges must be prepaid by you.
5. Once your return has been received by our warehouse, Maxi-Matic, USA will repair or replace the product if it is defective in material or workmanship, subject to the conditions in paragraph B.
6. Maxi-Matic will pay the shipping charges to ship the repaired or replacement product back to you.

Warning

This content is compiled from multiple sources and is provided for reference purposes only. It may not be complete or fully applicable to all situations. If you are unable to resolve your issue, please contact the product manufacturer or an authorized service provider for official support.

Document generated by [ManualsFile](#)