

## Chargers

Be sure to read all safety instructions before using your charger. Consult the chart at the end of this manual for compatibility of chargers and battery packs.

FIG. 1

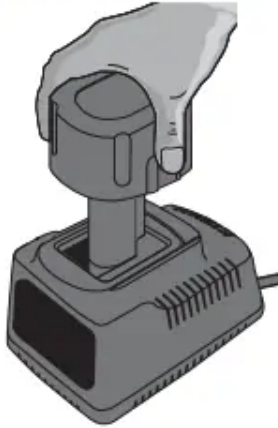

NiCd/NiMH/Li-Ion Tower Battery

Li-Ion Slide Battery



### Charging Procedure (Fig. 1)

**DANGER:** *Electrocution hazard. 120 volts are present at recessed terminals of the tower port. Do not probe with conductive objects. Electric shock or electrocution may result.*

1. Plug the charger into an appropriate outlet before inserting the battery pack.
2. Insert the battery pack into the correct charger port, as shown in Figure 1, making sure the pack is fully seated in the charger. The red (charging) light will blink continuously indicating that the charging process has started.
3. The completion of charge will be indicated by the red light remaining ON continuously. The pack is fully charged and may be used at this time or left in the charger.

### Charge Indicators

This charger is designed to detect certain problems that can arise. Problems are indicated by the red light flashing at a fast rate. If this occurs, re-insert the battery pack into the charger. If the problem persists, try a different battery pack to determine if the charger is working properly. If the new pack charges correctly, then the original pack is defective and should be returned to a service center or other collection site for recycling. If the new battery pack elicits the same trouble indication as the original, have the charger and the battery pack tested at an authorized service center.

## HOT/COLD DELAY

This charger has a hot/cold delay feature: when the charger detects a battery that is hot, it automatically starts a delay, suspending charging until the battery has cooled. After the battery has cooled, the charger automatically switches to the pack charging mode. This feature ensures maximum battery life. The red light flashes long, then short while in the hot/cold delay mode.

## LEAVING THE BATTERY PACK IN THE CHARGER

The charger and battery pack can be left connected with the charge indicator showing pack charged.

**WEAK BATTERY PACKS:** Weak batteries will continue to function but should not be expected to perform as much work.

**FAULTY BATTERY PACKS:** This charger will not charge a faulty battery pack. The charger will indicate faulty battery pack by refusing to light or by displaying problem pack or charger.

NOTE: This could also mean a problem with a charger.

## PROBLEM POWER LINE

Some chargers have a problem power line indicator. When the charger is used with some portable power sources such as generators or sources that convert DC to AC, the charger may temporarily suspend operation, flashing the red light with two fast blinks followed by a pause. This indicates the power source is out of limits.

## Important Charging Notes

1. Longest life and best performance can be obtained if the battery pack is charged when the air temperature is between 65 °F and 75 °F (18 ° – 24 °C). DO NOT charge the battery pack in an air temperature below +40 °F (+4.5 °C), or above +105 °F (+40.5 °C). This is important and will prevent serious damage to the battery pack.
2. The charger and battery pack may become warm to the touch while charging. This is a normal condition, and does not indicate a problem. To facilitate the cooling of the battery pack after use, avoid placing the charger or battery pack in a warm environment such as in a metal shed or an uninsulated trailer.
3. **LITHIUM ION ONLY:** A cold battery pack will charge at about half the rate of a warm battery pack. The battery pack will charge at that slower rate throughout the entire charging cycle and will not return to maximum charge rate even if the battery pack warms.
4. If the battery pack does not charge properly:
  - Check operation of the receptacle by plugging in a lamp or other appliance;

- Check to see if the receptacle is connected to a light switch which turns the power off when you turn out the lights;
- Move the charger and battery pack to a location where the surrounding air temperature is approximately 65 °F – 75 °F (18 ° – 24 °C);
- If charging problems persist, take the tool, battery pack and charger to your local service center.

5. The battery pack should be recharged when it fails to produce sufficient power on jobs which were easily done previously. **DO NOT CONTINUE** to use it under these conditions. Follow the charging procedure. You may also charge a partially used pack whenever you desire with no adverse effect on the battery pack.

6. Foreign materials of a conductive nature such as, but not limited to, grinding dust, metal chips, steel wool, aluminum foil, or any buildup of metallic particles should be kept away from charger cavities. Always unplug the charger from the power supply when there is no battery pack in the cavity. Unplug the charger before attempting to clean it.

7. Do not freeze or immerse the charger in water or any other liquid.

**WARNING:** *Shock hazard. Don't allow any liquid to get inside the charger. Electric shock may result.*

**WARNING:** *Burn hazard. Do not submerge the battery pack in any liquid or allow any liquid to enter the battery pack. Never attempt to open the battery pack for any reason. If the plastic housing of the battery pack breaks or cracks, return it to a service center for recycling.*

## Storage Recommendations

1. The best storage place is one that is cool and dry, away from direct sunlight and excess heat or cold.
2. For long storage, it is recommended to store a fully charged battery pack in a cool dry place out of the charger for optimal results.

NOTE: Battery packs should not be stored completely depleted of charge. The battery pack will need to be recharged before use.

## COMPONENTS

**WARNING:** *Never modify the power tool or any part of it. Damage or personal injury could result.*

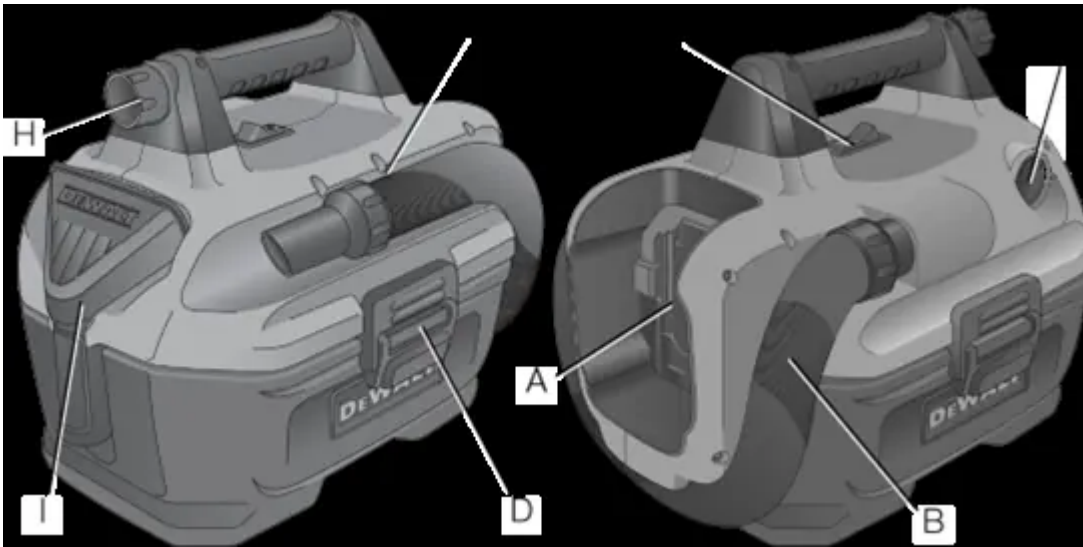

- A. Battery port
- B. Vacuum hose
- C. On/off button
- D. Tank latch
- E. Filter (Fig. 5)
- F. Side exhaust port
- G. Hose clip
- H. Crevice tool
- I. Wide nozzle tool

## INTENDED USE

The vacuum is designed to operate on a DEWALT 18V NiCd/NiHiD/ Li-Ion or a 20V Max\* Li-Ion battery pack. The battery pack and charger are sold separately.

The vacuum is designed to perform as a wet/dry unit with no component changes required when changing from wet to dry, or dry to wet pick up. This vacuum is for household use. It is recommended that the tank be emptied of any dry contents prior to being used for wet pick up to facilitate tank cleaning.

## OPERATION

**WARNING:** To reduce the risk of injury, turn unit off and disconnect it from power source before installing and removing accessories, before adjusting or when making repairs. An accidental start-up can cause injury.

## Installing and Removing the Battery Pack (Fig. 3)

# FIG. 3

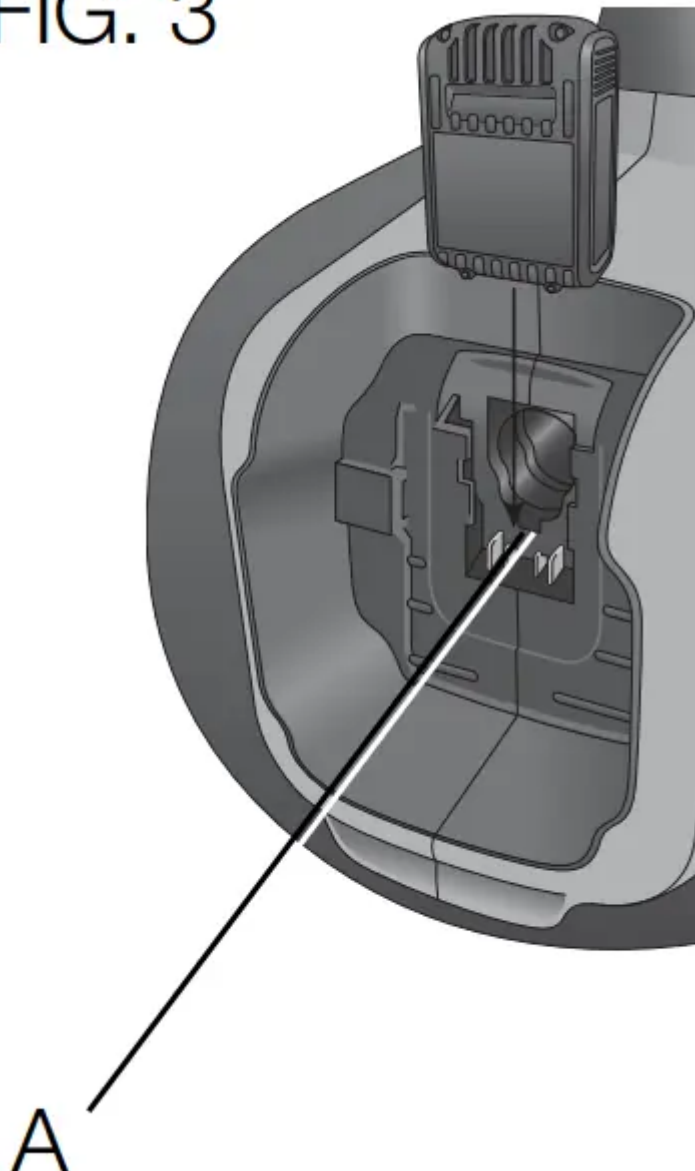

**NOTE:** Make sure your battery pack is fully charged.

To install the battery pack into the vacuum, insert/slide battery pack into battery port (A). Make sure the battery pack is fully seated.

To remove the battery pack from the vacuum, press and hold the battery release on the battery pack and remove. To charge the pack, insert it into your DEWALT charger.

## Using the Appliance (Fig. 2, 4)

1. Attach the appropriate accessory to FIG. 4 the hose (B).
2. Insert the DEWALT battery pack.
3. To turn machine on, press the I/O (on/off) button (C).

## Vacuum Cleaning

### TO EMPTY TANK (FIG. 5)

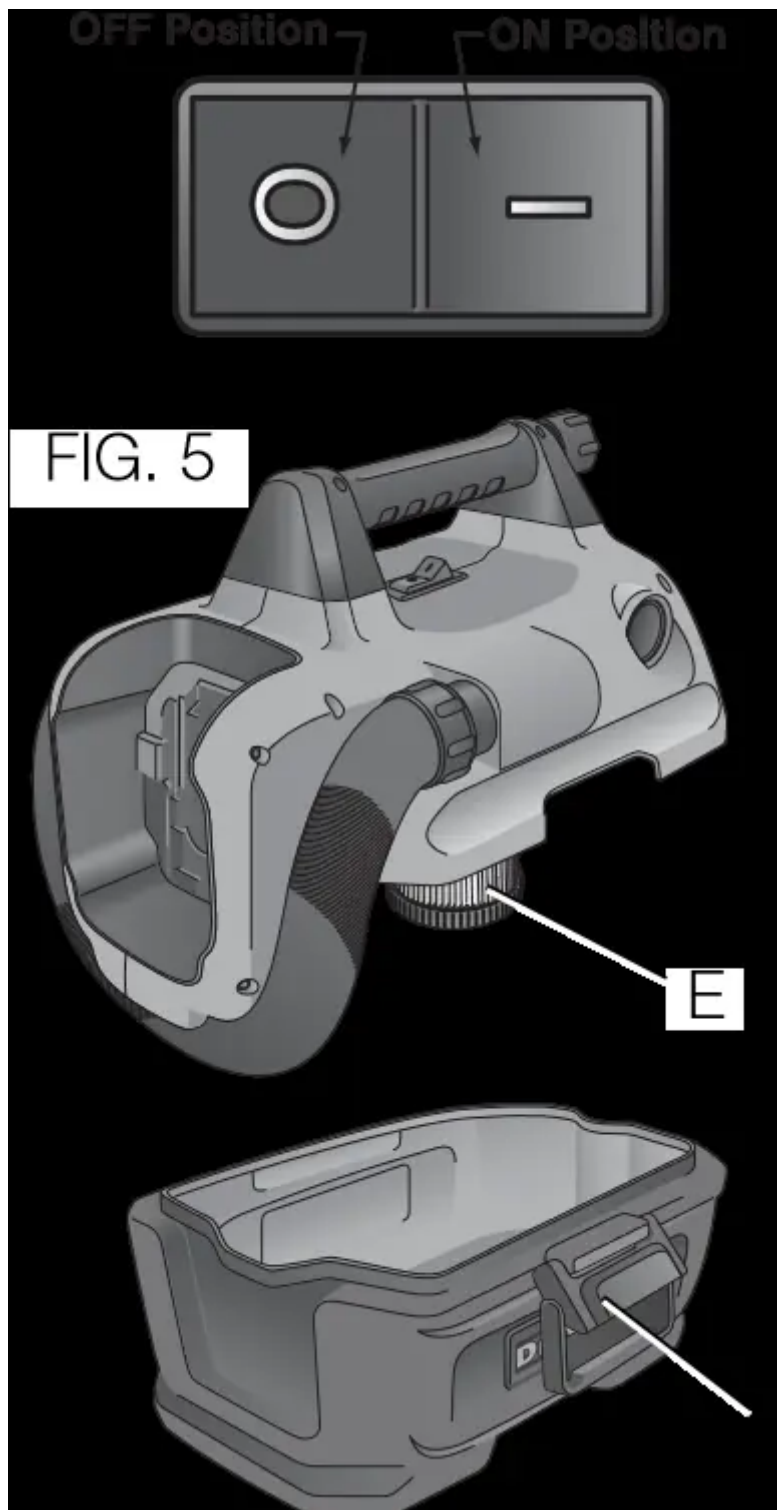

The sound of the motor changes and suction is reduced when the tank is full.

1. Turn machine off and remove the battery pack.
2. Unlatch the tank latches (D) and remove the power head from the tank.

3. Empty the contents of the tank into a suitable container.
4. Clean or change filters. See *Filter* section of this manual.
5. Inspect machine for damage by foreign objects. Contact the nearest DEWALT authorized service center for replacement of damaged or missing parts.
6. Replace power head onto the tank and latch securely.

NOTE: The machine must be used in the upright position at all times to prevent unwanted actuation of the Automatic Vacuum Shutoff. If unwanted actuation should happen, turn off the motor and wait until the motor stops turning. Turn the motor on again and suction will be restored.

### Filter (Fig. 6)

## FIG. 6

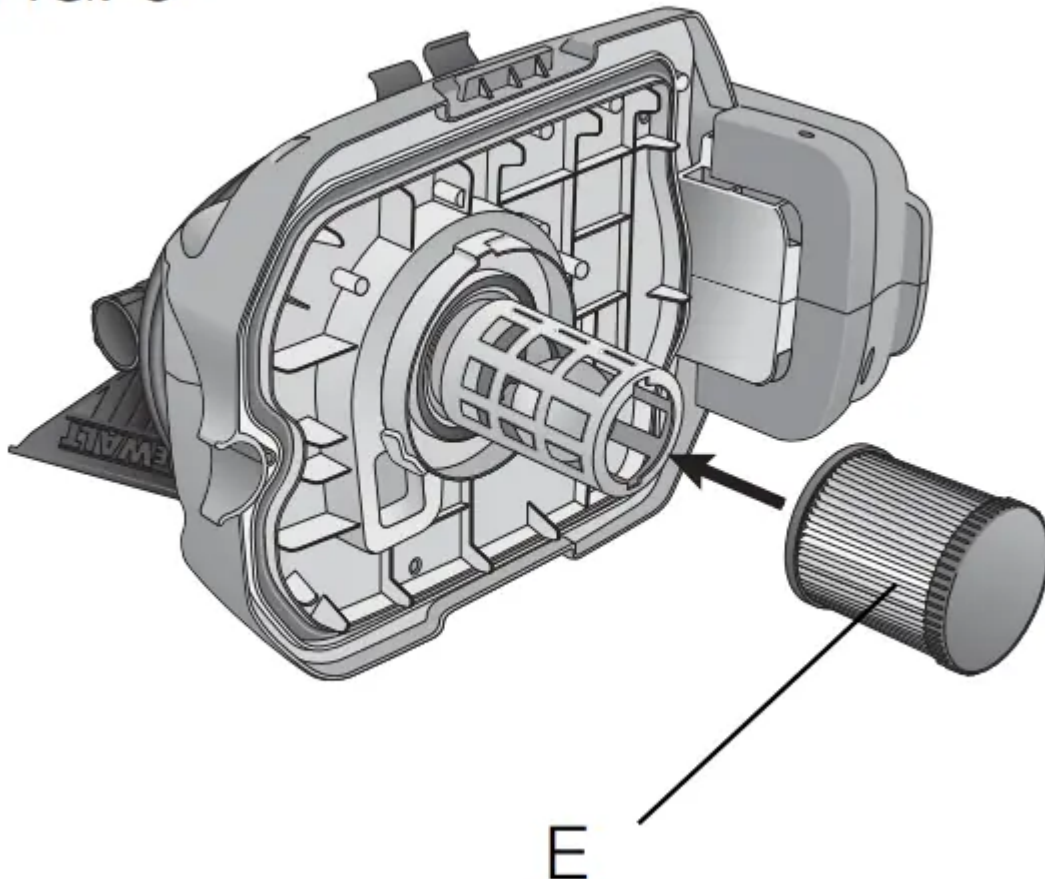

### FILTER CARE

The wet/dry filter (E) included with this vacuum is a long life filter. To be effective in minimizing dust recirculation the filters **MUST** be installed correctly and in good condition.

**NOTE:** Never operate without a filter in place. A clean filter is the most important factor in the operation and efficiency of any vacuum. If the filter becomes clogged beyond cleaning, damaged, or fails to operate properly, replace only with genuine DEWALT replacement filters.

### **TO CLEAN OR CHANGE THE FILTER**

1. Turn the machine off and FIG. 6 remove the battery pack.
2. Unlatch the tank latches (D) and remove the power head from the tank. Twist the filter (E) to the right to remove it from the power head.
3. Clean the filter by shaking off excess dust, tapping into a waste receptacle, then rinsing under running water. Depending on the condition of the filter, a water wash is not always required. Do not use a brush to clean filter.
4. Reinstall and secure the filter onto the power head by twisting the filter to the left.
5. Replace power head onto the tank and secure latches.

### **Blower (Fig. 2)**

The blower function can be used to remove debris from behind small spaces, to dry a damp floor, to blow grass clippings or leaves from an outside walk, patio, etc.

### **TO USE AS A BLOWER**

1. Empty the tank following the instructions under the Vacuum Cleaning section of this manual.
2. Twist the vacuum hose (B) to remove.
3. Insert the hose into the side exhaust port (F) and twist to secure.

## **MAINTENANCE**

***WARNING: To reduce the risk of injury, turn unit off and disconnect it from power source before installing and removing accessories, before adjusting or when making repairs. An accidental start-up can cause injury.***

- Empty the vacuum often, especially when wet debris is in the canister.
- MAINTAIN TOOL WITH CARE. Keep fan area clean for best and safest performance.
- Do not attempt to repair the vacuum. To assure product safety and reliability, repairs, maintenance, and adjustments should be performed by authorized DEWALT service centers.

## Hose and Accessory Storage (Fig. 2)

When the vacuum is not in use, the hose can be wrapped around the appliance, underneath the battery interface, and secured with the hose clip (G) also located at the back of the vacuum. The two accessories (crevice tool and wide nozzle) can be stored on board the vacuum as well

## Lubrication

Never lubricate the vacuum motor. The motor bearings are permanently sealed. This vacuum is intended for indoor use and for wet or dry pick up, but it is not intended to be exposed to rain.

## Cleaning

**WARNING:** Blow dirt and dust out of all air vents with clean, dry air at least once a week. To minimize the risk of eye injury, always wear ANSI Z87.1 approved eye protection when performing this.

**WARNING:** Never use solvents or other harsh chemicals for cleaning the non-metallic parts of the tool. These chemicals may weaken the plastic materials used in these parts. Use a cloth dampened only with water and mild soap. Never let any liquid get inside the tool; never immerse any part of the tool into a liquid.

## CHARGER CLEANING INSTRUCTIONS

**WARNING:** Shock hazard. Disconnect the charger from the AC outlet before cleaning. Dirt and grease may be removed from the exterior of the charger using a cloth or soft non-metallic brush. Do not use water or any cleaning solutions.

## Accessories (Fig. 2, 7)

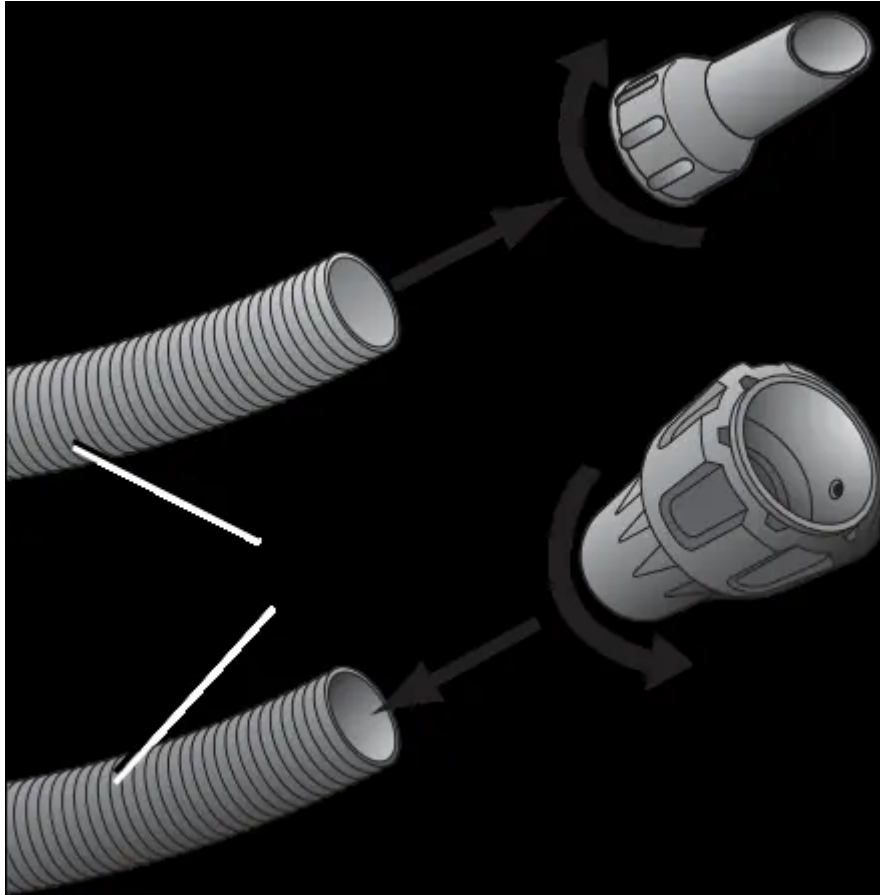

**WARNING:** Since accessories, other than those offered by DEWALT, have not been tested with this product, use of such accessories with this tool could be hazardous. To reduce the risk of injury, only DEWALT recommended accessories should be used with this product.

The DCV580 includes a 1-1/4" hose, crevice tool (stored in the handle) and wide nozzle.

A replacement filter is available at extra cost at your local DEWALT service center.

### DUST COLLECTOR (FIG. 7)

In the vacuum mode, the appliance can also function as a dust collector for power tool applications producing dust or debris.

Install the DWV9000 dust extraction adaptor, available at additional cost, to facilitate connection of a power tool to the vacuum hose ( B ).

1. Unscrew and remove the standard hose nozzle.
2. Screw on the dust extraction adaptor to the hose.
3. Attach the adaptor to the power tool.

**NOTE:** Follow these instructions in reverse to set up the appliance for standard vacuum use.

**IMPORTANT!** The DWV9000 dust extraction adaptor is designed to work with Dust System Compatible DEWALT power tools. An additional adaptor will be necessary for use with incompatible DEWALT tools.

Recommended accessories for use with your machine are available at extra cost from your local dealer or authorized service center. If you need assistance in locating any accessory, please contact DEWALT Industrial Tool Co., 701 East Joppa Road, Baltimore, MD 21286, call 1-800-4-DEWALT (1-800-433-9258) or visit our website: [www.dewalt.com](http://www.dewalt.com).

## Repairs

The charger and battery pack are not serviceable.

To assure product SAFETY and RELIABILITY, repairs, maintenance and adjustment (including brush inspection and replacement) should be performed by a DEWALT factory service center, a DEWALT authorized service center or other qualified service personnel. Always use identical replacement parts.

## Register Online

Thank you for your purchase. Register your product now for:

- **WARRANTY SERVICE:** Registering your product will help you obtain more efficient warranty service in case there is a problem with your product.
- **CONFIRMATION OF OWNERSHIP:** In case of an insurance loss, such as fire, flood or theft, your registration of ownership will serve as your proof of purchase.
- **FOR YOUR SAFETY:** Registering your product will allow us to contact you in the unlikely event a safety notification is required under the Federal Consumer Safety Act.

## IMPORTANT SAFETY INSTRUCTIONS

**WARNING:** *When using electric appliances, always follow basic safety precautions to reduce the risk of fire, electric shock and personal injury, including the following:*

### TO REDUCE RISK OF INJURY

- *Before any use, be sure everyone using this vacuum reads and understands all safety instructions and other information contained in this manual.*
- *Save these instructions and review frequently prior to use and in instructing others.*
- *Instructions for compatible batteries and chargers are included for reference in this manual. Read all instruction manuals included with your battery pack or charger. Read all cautionary markings on the charger and battery pack. Consult the chart at the end of this manual for compatibility of chargers and battery packs.*

When using this vacuum, basic safety precautions should always be followed including the following:

## **READ ALL INSTRUCTIONS BEFORE USING VACUUM**

**WARNING:** To reduce the risk of electric shock. Do not expose to rain. Store indoors.

- Do not leave the vacuum when connected to power source. Remove the battery pack when not in use and before servicing.
- Do not allow vacuum to be used as a toy. Close attention is necessary when used by or near children.
- Use this appliance **ONLY** as described in the manual. Use only DEWALT recommended attachments.
- Do not use this appliance if it is showing signs of malfunction in anyway. If the appliance is not working correctly, has been dropped, damaged, left outdoors, or dropped into water, return it to a service center.
- Do not handle the appliance with wet hands.
- Do not put any objects into the openings of the appliance. Do not use the appliance with any opening blocked; keep free of dust, lint, hair and anything else that may reduce air flow.
- Keep hair, loose clothing, fingers, and all body parts away from the openings and moving parts.
- Do not place outlet of vacuum near eyes or ears when operating.
- The blower operation can result in foreign objects being blown into eyes, which can result in eye damage. Always wear safety goggles when using blower feature.
- Use safety equipment. Always wear eye protection. Dust mask, non-skid safety shoes, hard hat, or hearing protection must be used for appropriate conditions.
- Use extra care when cleaning on stairs.
- Do not use without filter in place.
- Do not use the appliance to pick up flammable or combustible liquids, such as gasoline, or use in areas where flammable or combustible liquids are present.
- Do not pick up anything that is burning or smoking, such as cigarettes, matches or hot ashes.
- Do not use in areas where explosive vapors may be present.
- Do not use to pick up explosive dust, or in areas where air contains explosive dust such as coal, grain, or other combustible material.

- *Static shocks are possible in dry areas or when the relative humidity of the air is low. This is only temporary and does not affect the use of the vacuum. To reduce the frequency of static shocks, add moisture to the air with a console or installed humidifier.*
- *To avoid spontaneous combustion, empty canister after each use.*
- *Store idle tools. When not in use, the vacuum should be stored in a dry, high or locked up place – out of the reach of children.*
- *Disconnect the battery pack from the vacuum before making any adjustments, changing accessories, servicing, moving or storing the vacuum. Such preventative safety measures reduce the risk of starting the appliance accidentally.*
- *Avoid accidental starting. Be sure the switch is in the OFF position before inserting the battery pack.*
- *Never leave vacuum running unattended. Turn power off.*
- *Keep your work area clean and well lit. Cluttered benches and dark areas invite accidents.*
- *Do not overreach. Keep proper footing and balance at all times. Proper footing and balance enables better control of the vacuum in unexpected situations.*
- *Do not use appliance if switch does not turn it on or off. Any appliance that cannot be controlled with the switch is dangerous and must be repaired.*
- *Turn off all controls before removing the battery pack.*

## **SAVE THESE INSTRUCTIONS**

### **ADDITIONAL SAFETY RULES**

**WARNING:** *When not in use, place vacuum on a stable surface where it will not cause a tripping or falling hazard.*

- *Do not use vacuum as a step ladder.*
- *Do not place heavy objects on vacuum.*
- *Air vents often cover moving parts and should be avoided. Loose clothes, jewelry or long hair can be caught in moving parts.*

**WARNING: ALWAYS** use safety glasses. Everyday eyeglasses are NOT safety glasses. Also use face or dust mask if cutting operation is dusty. **ALWAYS WEAR CERTIFIED SAFETY EQUIPMENT:**

- *ANSI Z87.1 eye protection (CAN/CSA Z94.3),*
- *ANSI S12.6 (S3.19) hearing protection, • NIOSH/OSHA/MSHA respiratory protection.*

**WARNING:** Some dust created by power sanding, sawing, grinding, drilling, and other construction activities contains chemicals known to the State of California to cause cancer, birth defects or other reproductive harm. Some examples of these chemicals are:

- lead from lead-based paints,
- crystalline silica from bricks and cement and other masonry products, and
- arsenic and chromium from chemically-treated lumber.

Your risk from these exposures varies, depending on how often you do this type of work. To reduce your exposure to these chemicals: work in a well ventilated area, and work with approved safety equipment, such as those dust masks that are specially designed to filter out microscopic particles.

- Avoid prolonged contact with dust from power sanding, sawing, grinding, drilling, and other construction activities. Wear protective clothing and wash exposed areas with soap and water. Allowing dust to get into your mouth, eyes, or lay on the skin may promote absorption of harmful chemicals.

**WARNING:** Use of this tool can generate and/or disperse dust, which may cause serious and permanent respiratory or other injury. Always use NIOSH/OSHA approved respiratory protection appropriate for the dust exposure. Direct particles away from face and body.

**WARNING:** Always wear proper personal hearing protection that conforms to ANSI S12.6 (S3.19) during use. Under some conditions and duration of use, noise from this product may contribute to hearing loss.

## **Additional Specific Safety Rules for All Battery-Operated Tools**

- A battery-operated tool with integral batteries or a separate battery pack must be recharged only with the specified charger for the battery pack. A charger that may be suitable for one type of battery pack may create a risk of fire when used with another battery pack.
- Use battery-operated tool only with the specifically designed DEWALT battery pack. Use of any other batteries may create a risk of fire.
- When battery pack is not in use, keep it away from other metal objects like: paper clips, coins, keys, nails, screws, or other small metal objects that can make a connection from one terminal to another. Shorting the battery terminals together may cause sparks, burns, or a fire.
- The label on your tool may include the following symbols. The symbols and their definitions are as follows:

V.....	volts	A.....	amperes
Hz.....	hertz	W.....	watts
min.....	minutes	~ or AC.....	alternating current
== or DC...	direct current	≈ or AC/DC...	alternating or direct current
Ⓜ.....	Class I Construction (grounded)	$n_0$ .....	no load speed
□.....	Class II Construction (double insulated)	n.....	rated speed
.../min.....	per minute	⊕.....	earthing terminal
BPM.....	beats per minute	▲.....	safety alert symbol
IPM.....	impacts per minute		
RPM.....	revolutions per minute		
sfpn.....	surface feet per minute		
SPM.....	strokes per minute		

### Important Safety Instructions for All Battery Packs

When ordering replacement battery packs, be sure to include the catalog number and voltage. Consult the chart at the end of this manual for compatibility of chargers and battery packs.

The battery pack is not fully charged out of the carton. Before using the battery pack and charger, read the safety instructions below and then follow charging procedures outlined.

#### READ ALL INSTRUCTIONS

- Do not charge or use the battery pack in explosive atmospheres, such as in the presence of flammable liquids, gases or dust. Inserting or removing the battery pack from the charger may ignite the dust or fumes.
- NEVER force the battery pack into the charger. DO NOT modify the battery pack in any way to fit into a noncompatible charger as battery pack may rupture causing serious personal injury. Consult the chart at the end of this manual for compatibility of batteries and chargers.
- Charge the battery packs only in designated DEWALT chargers.
- DO NOT splash or immerse in water or other liquids.

- Do not store or use the tool and battery pack in locations where the temperature may reach or exceed 105 °F (40 °C) (such as outside sheds or metal buildings in summer). For best life store battery packs in a cool, dry location.

**NOTE:** Do not store the battery pack in a tool with the trigger switch locked on. Never tape the trigger switch in the ON position.

**DANGER:** Electrocutation hazard. Never attempt to open the tower battery pack for any reason. If the tower battery pack case is cracked or damaged, do not insert into the charger. Do not crush, drop or damage the tower battery pack. Do not use a tower battery pack or charger that has received a sharp blow, been dropped, run over or damaged in any way (e.g., pierced with a nail, hit with a hammer, stepped on). Damaged tower battery packs should be returned to the service center for recycling.

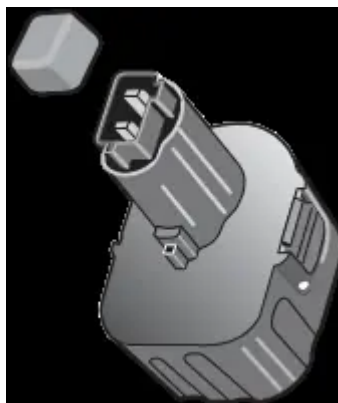

**NOTE:** The battery storage and carrying caps are provided for use whenever the tower battery pack is out of the tool or charger. Remove the cap before placing battery pack in charger or tool.

**WARNING:** Fire hazard. Do not store or carry the battery pack so that metal objects can contact exposed battery terminals. For example, do not place the battery pack in aprons, pockets, tool boxes, product kit boxes, drawers, etc., with loose nails, screws, keys, etc. Transporting batteries can possibly cause fires if the battery terminals inadvertently come in contact with conductive materials such as keys, coins, hand tools and the like. The US Department of Transportation Hazardous Material Regulations (HMR) actually prohibit transporting batteries in commerce or on airplanes (e.g., packed in suitcases and carry-on luggage) UNLESS they are properly protected from short circuits. So when transporting individual battery packs, make sure that the battery terminals are protected and well insulated from materials that could contact them and cause a short circuit.

**WARNING:** Fire hazard. Never attempt to open the slide battery pack for any reason. If the slide battery pack case is cracked or damaged, do not insert into the charger. Do not crush, drop or damage the slide battery pack. Do not use a slide battery pack or charger that has received a sharp blow, been dropped, run over or damaged in any way (e.g., pierced with a nail, hit with a hammer, stepped on). Damaged slide battery packs should be returned to the service center for recycling.

## **SPECIFIC SAFETY INSTRUCTIONS FOR NICKEL CADMIUM (NiCd) OR NICKEL METAL HYDRIDE (NiMH)**

- *Do not incinerate the battery pack even if it is severely damaged or is completely worn out. The battery pack can explode in a fire.*
- *A small leakage of liquid from the battery pack cells may occur under extreme usage or temperature conditions. This does not indicate a failure.*

*However, if the outer seal is broken:*

- a. and the battery liquid gets on your skin, immediately wash with soap and water for several minutes.*
- b. and the battery liquid gets into your eyes, flush them with clean water for a minimum of 10 minutes and seek immediate medical attention. (Medical note: The liquid is 25–35% solution of potassium hydroxide.)*

## **SPECIFIC SAFETY INSTRUCTIONS FOR LITHIUM ION (Li-Ion)**

- *Do not incinerate the battery pack even if it is severely damaged or is completely worn out. The battery pack can explode in a fire. Toxic fumes and materials are created when lithium ion battery packs are burned.*
- *If battery contents come into contact with the skin, immediately wash area with mild soap and water. If battery liquid gets into the eye, rinse water over the open eye for 15 minutes or until irritation ceases. If medical attention is needed, the battery electrolyte is composed of a mixture of liquid organic carbonates and lithium salts.*
- *Contents of opened battery cells may cause respiratory irritation. Provide fresh air. If symptoms persist, seek medical attention.*

**WARNING:** *Burn hazard. Battery liquid may be flammable if exposed to spark or flame.*

### **The RBRC™ Seal**

The RBRC™ (Rechargeable Battery Recycling Corporation) Seal on the nickel cadmium, nickel metal hydride or lithium ion batteries (or battery packs) indicate that the costs to recycle these batteries (or battery packs) at the end of their useful life have already been paid by DEWALT. In some areas, it is illegal to place spent nickel cadmium, nickel metal hydride or lithium ion batteries in the trash or municipal solid waste stream and the RBRC program provides an environmentally conscious alternative.

RBRC™, in cooperation with DEWALT and other battery users, has established programs in the United States and Canada to facilitate the collection of spent nickel cadmium, nickel metal hydride or lithium ion batteries. Help protect our environment and conserve natural resources by returning the spent nickel cadmium, nickel metal hydride or lithium ion batteries

to an authorized DEWALT service center or to your local retailer for recycling. You may also contact your local recycling center for information on where to drop off the spent battery.

RBRC™ is a registered trademark of the *Rechargeable Battery Recycling Corporation*.

### Using Automatic Tune-Up™ Mode (NiCd/NiMH only)

The automatic Tune-Up™ Mode equalizes or balances the individual cells in the battery pack allowing it to function at peak capacity. Battery packs should be tuned up weekly or after 10 charge/ discharge cycles or whenever the pack no longer delivers the same amount of work. To use the automatic Tune-Up™, place the battery pack in the charger and leave it for at least 8 hours. The charger will cycle through the following modes.

1. The red light will blink continuously indicating that the 1-hour charge cycle has started.
2. When the 1-hour charge cycle is complete, the light will stay on continuously and will no longer blink. This indicates that the pack is fully charged and can be used at this time.
3. If the pack is left in the charger after the initial 1-hour charge, the charger will begin the Automatic Tune-Up mode. This mode continues up to 8 hours or until the individual cells in the battery pack are equalized. The battery pack is ready for use and can be removed at any time during the Tune-Up mode.
4. Once the Automatic Tune Up mode is complete, the charger will begin a maintenance charge; the red indicator will remain lit.

### Important Safety Instructions for All Battery Chargers

**SAVE THESE INSTRUCTIONS:** *This manual contains important safety and operating instructions for battery chargers.*

- *Before using the charger, read all instructions and cautionary markings on the charger, battery pack and product using the battery pack.*

**DANGER:** *Electrocution hazard. 120 volts are present at recessed terminals of the tower port. Do not probe with conductive objects. Electric shock or electrocution may result.*

**WARNING:** *Shock hazard. Do not allow any liquid to get inside the charger. Electric shock may result.*

**CAUTION:** *Burn hazard. To reduce the risk of injury, charge only DEWALT rechargeable battery packs. Other types of batteries may overheat and burst resulting in personal injury and property damage.*

**NOTICE:** *Under certain conditions, with the charger plugged into the power supply, the charger can be shorted by foreign material. Foreign materials of a conductive nature, such as, but not limited to, grinding dust, metal chips, steel wool, aluminum foil or any buildup of metallic particles should be kept away from the charger cavities. Always unplug the charger*

*from the power supply when there is no battery pack in the cavity. Unplug the charger before attempting to clean it.*

- DO NOT attempt to charge the battery pack with any chargers other than the ones in this manual. The charger and battery pack are specifically designed to work together.*
- These chargers are not intended for any uses other than charging DEWALT rechargeable batteries. Any other uses may result in risk of fire, electric shock or electrocution.*
- Do not expose the charger to rain or snow.*
- Pull by the plug rather than the cord when disconnecting the charger. This will reduce the risk of damage to the electric plug and cord.*
- Make sure that the cord is located so that it will not be stepped on, tripped over or otherwise subjected to damage or stress.*
- Do not use an extension cord unless it is absolutely necessary. Use of improper extension cord could result in risk of fire, electric shock or electrocution.*
- When operating a charger outdoors, always provide a dry location and use an extension cord suitable for outdoor use. Use of a cord suitable for outdoor use reduces the risk of electric shock.*
- An extension cord must have adequate wire size (AWG or American Wire Gauge) for safety. The smaller the gauge number of the wire, the greater the capacity of the cable, that is, 16 gauge has more capacity than 18 gauge. An undersized cord will cause a drop in line voltage resulting in loss of power and overheating. When using more than one extension to make up the total length, be sure each individual extension contains at least the minimum wire size. The following table shows the correct size to use depending on cord length and nameplate ampere rating. If in doubt, use the next heavier gauge. The lower the gauge number, the heavier the cord.*

Minimum Gauge for Cord Sets						
Ampere Rating		Volts	Total Length of Cord in Feet (meters)			
		120V	25 (7.6)	50 (15.2)	100 (30.5)	150 (45.7)
		240V	50 (15.2)	100 (30.5)	200 (61.0)	300 (91.4)
More Than	Not More Than	AWG				
0	6		18	16	16	14
6	10		18	16	14	12
10	12		16	16	14	12
12	16		14	12	Not Recommended	

- Do not place any object on top of the charger or place the charger on a soft surface that might block the ventilation slots and result in excessive internal heat. Place the charger in a position away from any heat source. The charger is ventilated through slots in the top and the bottom of the housing.
- Do not operate the charger with a damaged cord or plug.
- Do not operate the charger if it has received a sharp blow, been dropped or otherwise damaged in any way. Take it to an authorized service center.
- **Do not disassemble the charger; take it to an authorized service center when service or repair is required.** Incorrect reassembly may result in a risk of electric shock, electrocution or fire.
- **Disconnect the charger from the outlet before attempting any cleaning. This will reduce the risk of electric shock.** Removing the battery pack will not reduce this risk.
- **NEVER** attempt to connect 2 chargers together.
- **The charger is designed to operate on standard 120 volt household electrical power. Do not attempt to use it on any other voltage. This does not apply to the vehicular charger**

### Warning

This content is compiled from multiple sources and is provided for reference purposes only. It may not be complete or fully applicable to all situations. If you are unable to resolve your issue, please contact the product manufacturer or an authorized service provider for official support.