

## PARTS AND FEATURES

### REPLACEMENT PARTS

Item	Part No.
HEPA Filter	561051107
Pre-filter Basket	561059102
Brush Roll	561059103
2-in-1 Combination Tool	561051104
Charging Adapter	561051105
Wall Mountable Bracket	561051102
Screw (2)	561011130

To order a replacement part call  
1-844-202-9924

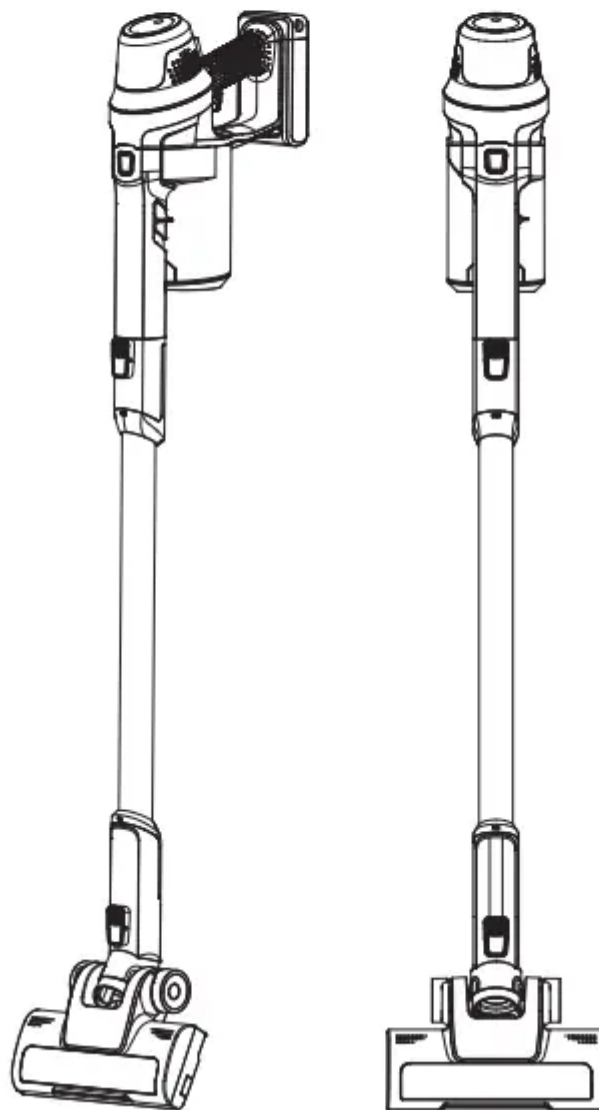

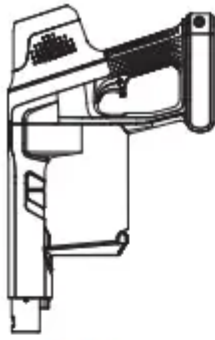

Hand Vacuum



Charging Adapter

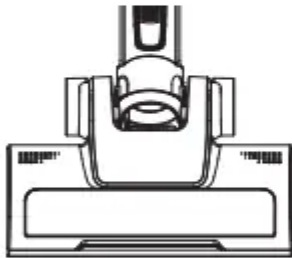

Motorized Nozzle



Wand



Wall Mountable Bracket



Screw (2)



2-in-1 Combination Tool

The motorized nozzle and the combination tool can be inserted into either the hand vacuum or the wand. You will hear a click if the motorized nozzle installed correctly.

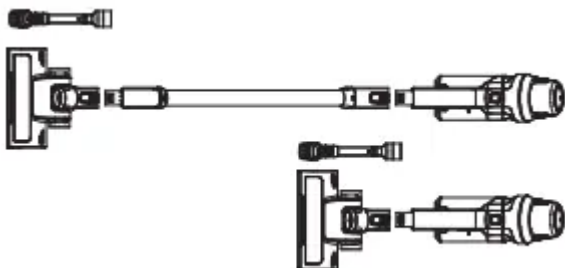

## Combination Tool

The combination brush can be used as a crevice tool or as a dusting brush. To use as a dusting brush, simply squeeze the buttons in the side of the tool and shift brush forward.

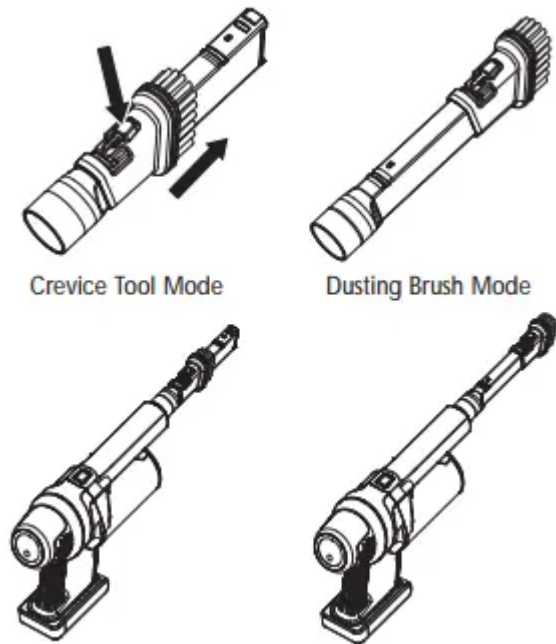

NOTE: For proper electrical contact, always be sure that metal contact surfaces of the motorized nozzle, the wand and the hand vacuum are clean before use.

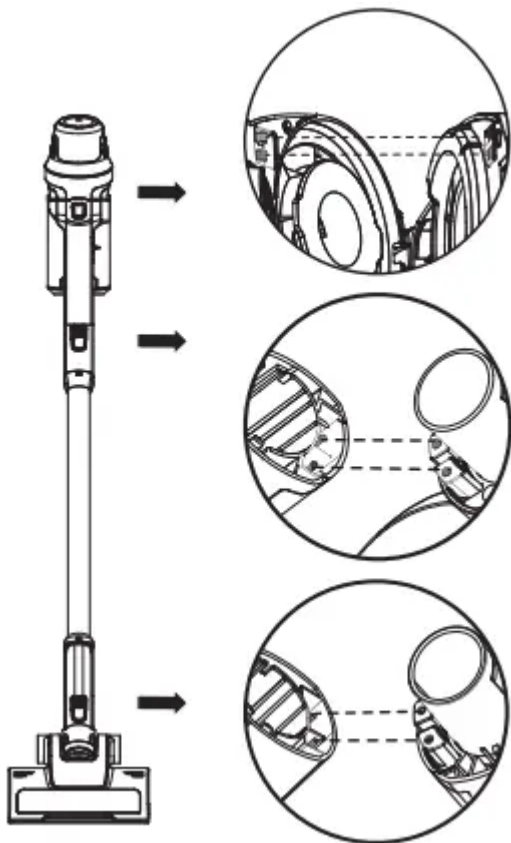

## Friction Hold Stoppers

The back of the hand vacuum features two rubber stoppers. When you lean the stick vac against a wall, the stoppers help prevent the unit from slipping down and possibly being damaged.

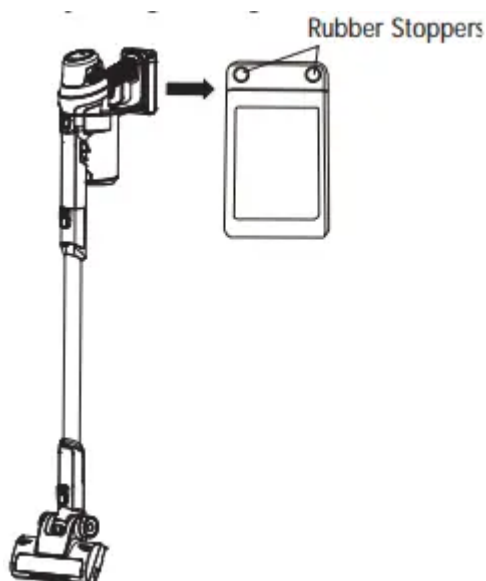

## ASSEMBLY INSTRUCTIONS

Before assembling the vacuum cleaner, check the PACKING LIST (Page 2). Use this list to verify that you have received all the components of your new Kenmore CSV Go Cordless Stick Vac

1. Insert the hand vacuum into the top of the wand until you hear a click.

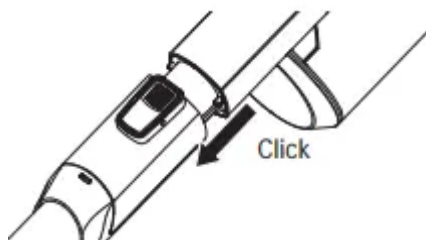

2. Insert the bottom of the wand into the motorized nozzle until you hear a click.

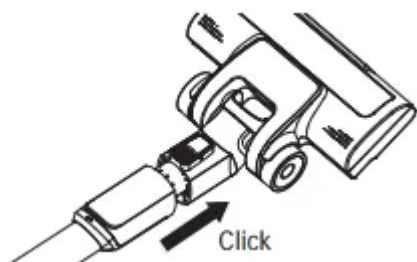

3. Use the 2 screws provided to mount the bracket on the wall, but not to drywall only. Secure the screws to a stud. Mount at a recommended height of 59" and no less than 44" above the floor. Ensure that no plumbing or electrical cables, wires or ductwork are located directly behind the mounting area.

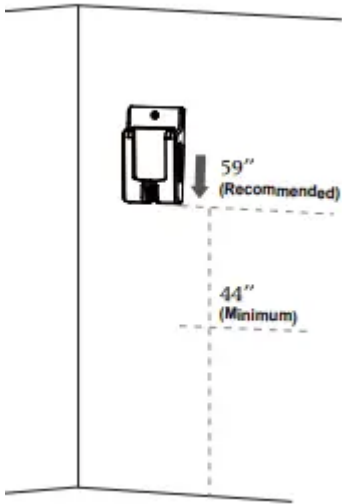

4. Hang the hand vacuum on the wall mount. Align the base of the hand vacuum with the wall mount and slide in as shown in the picture below

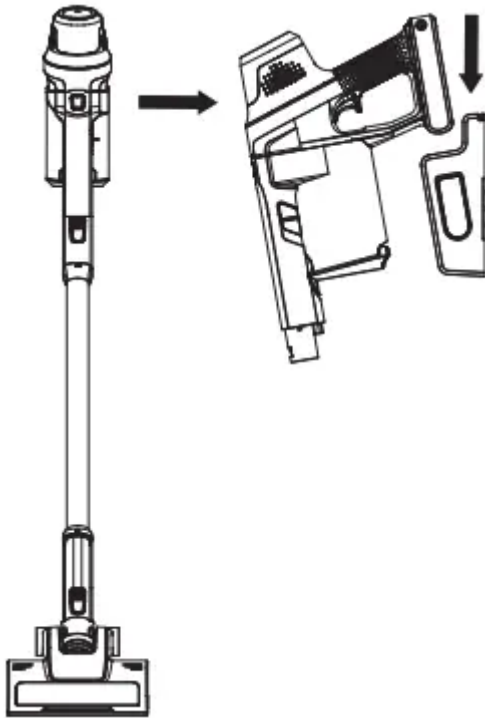

NOTE: To be able to charge vacuum while it is mounted, attach bracket to wall no more than 59" from wall electrical outlet.

## CHARGING

1. Insert the charging adapter plug into the charging port on the side of the hand vacuum base.
2. Plug the adapter into a wall outlet. The battery indicator will begin to pulse blue

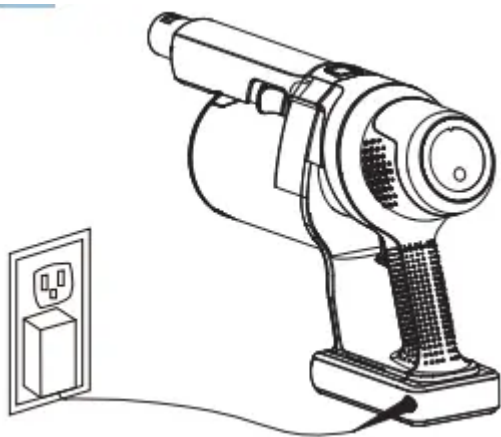

NOTE: The unit can be charged while it is hung on the wall mountable bracket. Attach bracket to wall no more than 59" from a wall electrical outlet.

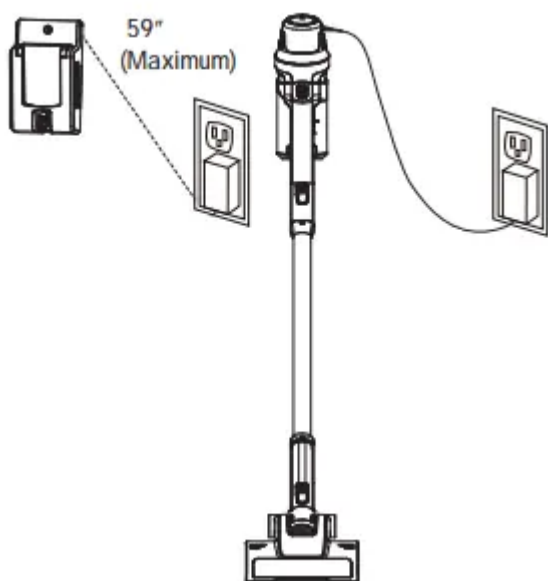

The battery requires approximately 4 hours of charging to regain full capacity. While the unit is charging, the battery indicator ring will pulse blue. When the battery is fully charged, the battery indicator will show a continuous blue light, and turn off after 15 minutes

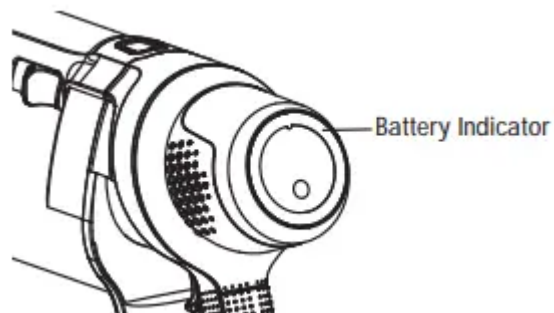

NOTE: If the battery indicator does not illuminate when charging, ensure that the charging adapter is plugged in properly to the wall outlet and the charging port on the hand vacuum.

For better battery performance, it is recommended to charge the unit when the battery indicator shows a continuous yellow light during operation, and remove the charging adapter from the unit after the battery is fully charged.

Never charge the batteries in temperatures above 104°F (40°C) or below 39.2°F (4°C). It is normal for the charger to become warm when charging.

## OPERATING INSTRUCTIONS

### CONTROL BUTTONS

The on/off trigger button is located on the inner side of the hand vacuum handle. The vacuum has two-speed controls, ECO and HIGH. Change speed by pressing the speed change button shown below.

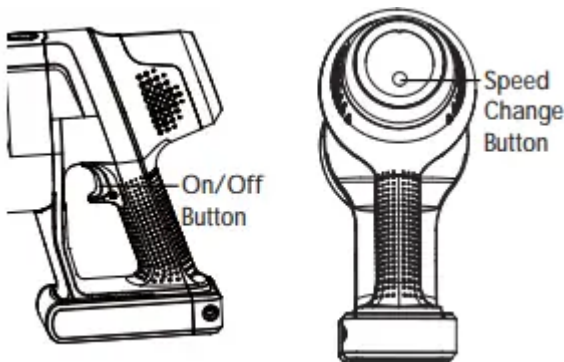

### Battery Power Level Indicator

The battery power level indicator lights up to give you an idea of how much battery power remains at any given time.

Battery Power Level Indicator	Battery Capacity
Blue, Continuous	75%~100%
Green, Continuous	50%~74%
Yellow, Continuous	25%~49% (Recharge recommended)
Red, Continuous	10%~24%
Red, Flashing	0~9% (Recharge required)

### VACUUM OPERATION

Before vacuuming floors, connect the motorized nozzle to the wand. Then connect the hand vacuum to the wand. The motorized nozzle can be used for cleaning carpets or rugs, as well as hard floors

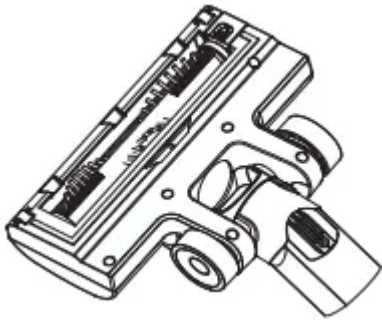

To start the vacuum, press the on/off trigger button. Once turned on, the battery level indicator will be lit.

The vacuum starts in the ECO speed position. To switch the speed to HIGH, press the speed change button. Press the speed change button again to switch back to ECO speed.

To turn the vacuum off, press the on/off trigger button again.

When vacuuming on plush carpet, use ECO mode for best performance.

NOTE: When battery power decreases to about 10% remaining, the battery level indicator will start red flashing. The flashing will continue until the unit is charged or is completely out of battery power

## CLEANING WITH THE HAND VACUUM

Easily clean messes on furniture, upholstery, stairs and other hard-to-reach areas with the included combination tool.

1. To detach the hand vacuum, press the wand release button and pull the wand from the hand vacuum

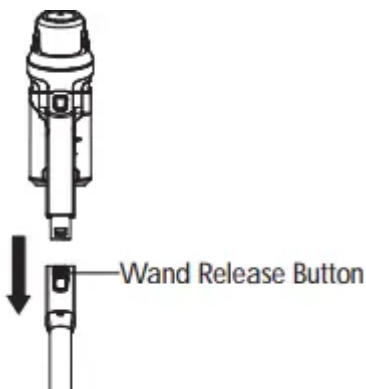

2. Install the combination tool onto the end of the hand vacuum.

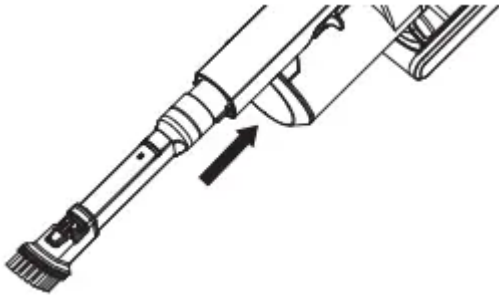

3. When finished cleaning, turn the hand vacuum OFF and remove the combination tool.

## VACUUM MAINTENANCE AND CARE

### EMPTYING DUST CUP AND CLEANING FILTER

#### Dust Cup Emptying

For best performance, empty dust cup after every use or once dust reaches max fill line. Never operate the vacuum cleaner without dust cup and filter in place.

Before emptying the dust cup, ensure the vacuum is turned off.

1. Position dust cup lid area of vacuum over a waste receptacle. Press down the dust cup release latch to open dust cup lid and allow cup contents to drop into waste receptacle.

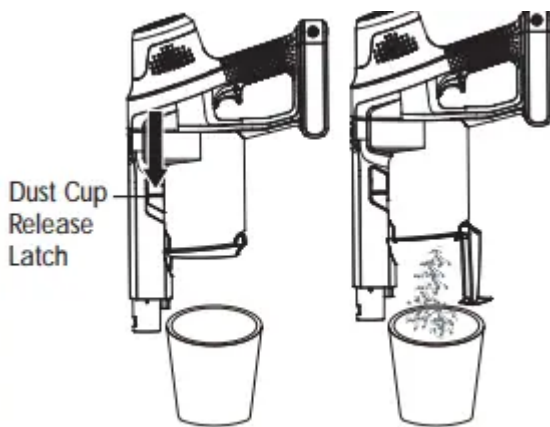

2. Close dust cup lid until you hear a click.

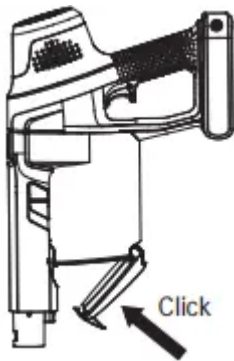

#### Filter Cleaning

If there is hair wrapped or blocked in the dust cup or the suction power is weak, it is necessary to wash the HEPA filter and pre-filter basket to clean off accumulated dust or hair.

**WARNING:** Do not operate vacuum cleaner without filters in place.

1. With one hand grasped around the handle, press the filter release button to separate the dust cup and filters from the hand vacuum.

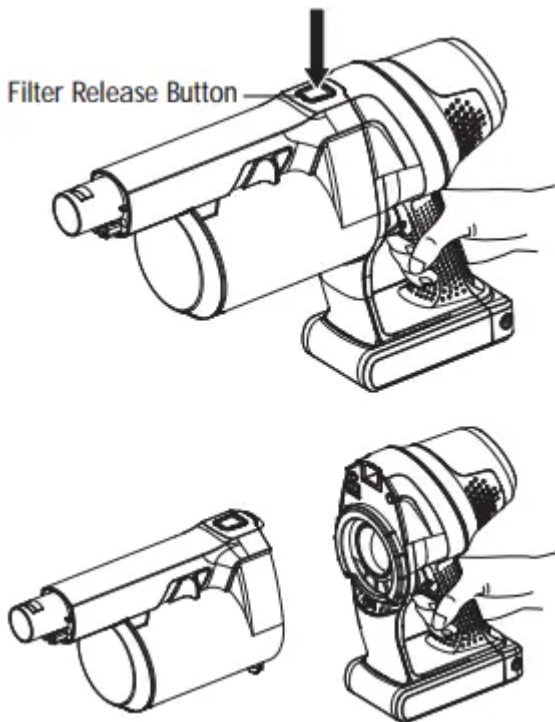

2. Remove the HEPA filter and pre-filter basket from the dust cup.

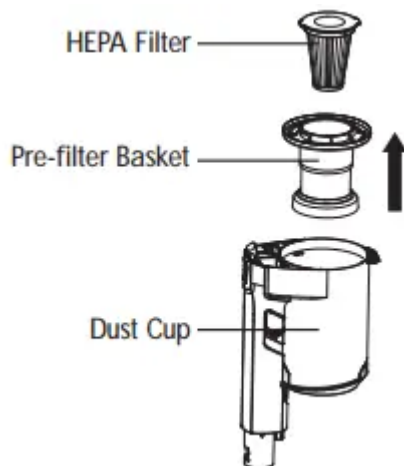

3. Brush loose debris from HEPA filter and pre-filter basket and then rinse with warm water. Set both filters aside and allow to air dry for 24 hours.

**IMPORTANT:** The HEPA filter and pre-filter must dry completely before reuse.

4. Place the pre-filter basket back into the dust cup, then place the HEPA filter back into the pre-filter basket.

5. To reassemble the dust cup to the hand vacuum, align the tabs on the dust cup with slots in the hand vacuum. Once aligned, attach the dust cup to the hand vacuum until you hear a click.

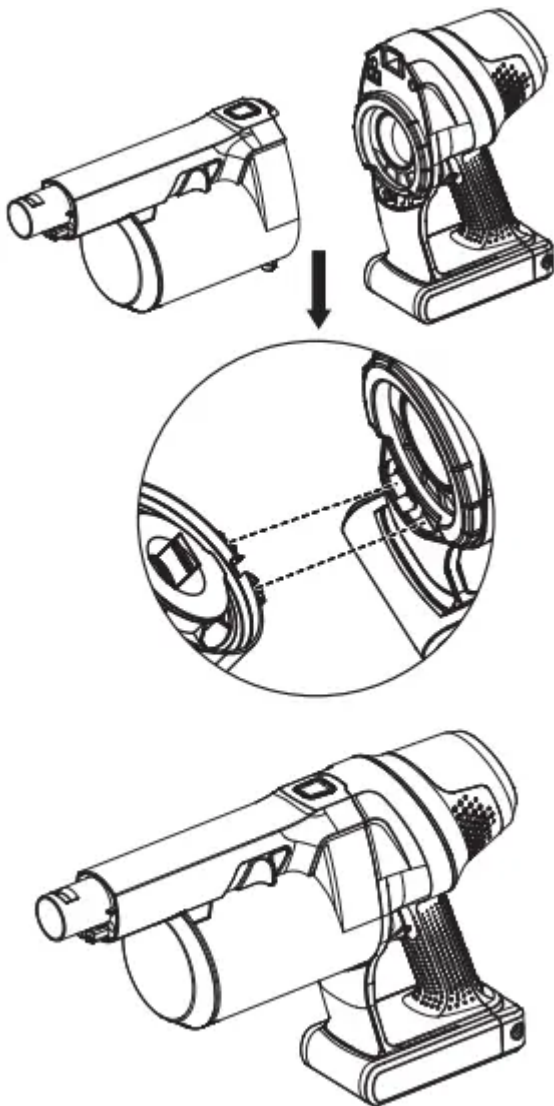

## **CLEANING THE MOTORIZED NOZZLE & BLOCKAGES**

The brush roll may accumulate debris such as strings, hair and fibers. This type of debris can wrap around the brush and diminish its ability to clean effectively.

### **Brush Roll Manual Cleaning**

1. Make sure the vacuum cleaner is turned off. Remove the wand and the hand vacuum from the motorized nozzle and set aside.
2. Turn the nozzle over to access the brush roll. As shown below, press and push the tab on the left hand side of the nozzle to the left and hold it. This will unlock the brush roll.

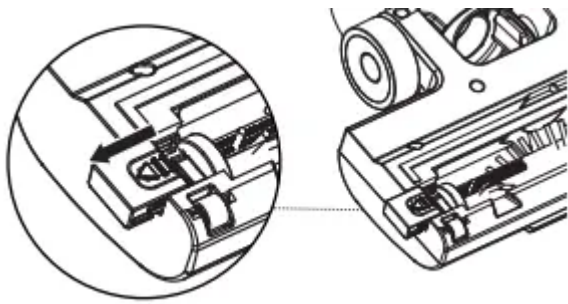

3. With the tab pushed to the left, simply lift the brush roll out of the nozzle housing. Clean off debris and anything wrapped around the brush roll. Use a pair of scissors to remove threads, etc.

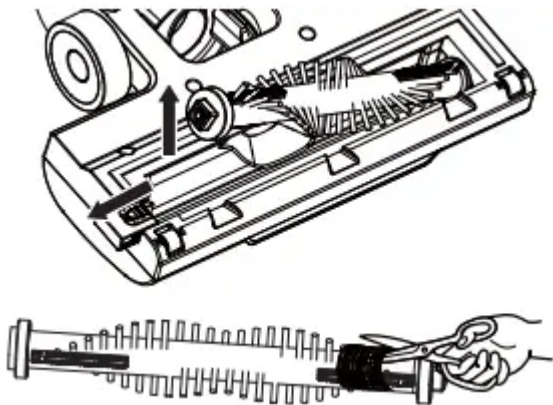

4. Place the brush roll back into the housing by aligning the hexagon end of the brush roll into the right end of the nozzle. Then push the unlock tab to the left and hold it. Align the square end of the brush roll with the left end of the nozzle and insert it into place. Release the tab to lock the brush roll.

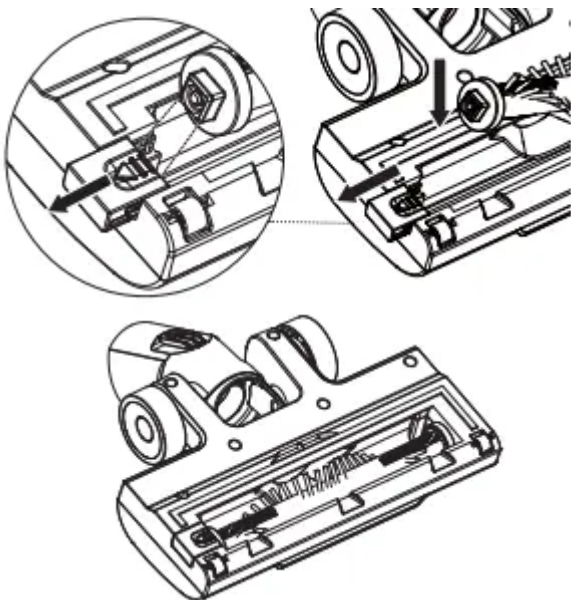

### **Brush Roll Reset**

If the brush roll is blocked or overloaded, the unit will automatically stop power. Switch the unit off and remove the obstruction.

### **Hose Blockage Removal**

1. To clean out the hose, press the wand release button on the motorized nozzle, and pull the motorized nozzle away from the wand.

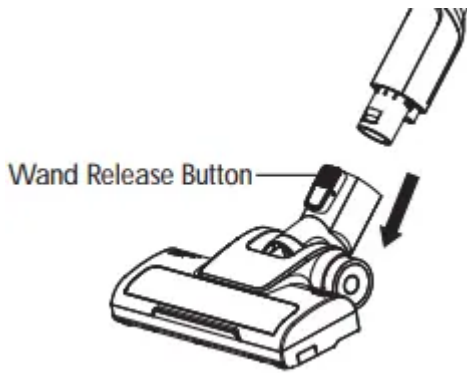

2. Carefully remove any debris or blockage from the inside of the hose. Reattach the motorized nozzle onto the wand.

3. Once the blockage is removed, start the vacuum to ensure air flow through the hose.

## TROUBLESHOOTING

Review the table for solutions to minor performance problems. Any service needed, other than maintenance described in this Use & Care Guide, should be performed by a qualified service dealer

<b>PROBLEM</b>	<b>POSSIBLE CAUSE</b>	<b>SOLUTION</b>
Vacuum will not power on.	Battery may be depleted.	Charge the battery as instructed
	Wrong charger being used.	Be sure to use only the charger supplied with your product.
	Brush roll is jammed.	Remove obstruction. Follow instructions on page 15.
	Hand vacuum or battery is damaged.	Call 1-877-531-7321 for assistance.
Battery indicator does not illuminate when charging the battery	Charging adapter is not plugged into outlet firmly	Be sure the charging adapter is plugged in properly to the outlet, and the charging connector is plugged into the charging port of the hand vacuum.
	Dust accumulated on the charging port of the hand vacuum.	Clean off any dust accumulated on the charging port of the hand vacuum.
	No power at electrical outlet	Check circuit breakers.
	The battery is damaged.	Call 1-877-531-7321 for assistance.
	The battery indicator is damaged.	Call 1-877-531-7321 for assistance.
Battery indicator does not illuminate when using the vacuum.	Battery may be depleted.	Charge the battery as instructed
	The battery indicator is damaged.	Call 1-877-531-7321 for assistance.
Battery indicator red flashes and then turns off when using the vacuum.	This indicates an obstruction of brush roll or missing of the filters, which causes the motor protection to trip.	With the unit turned off, check to remove any obstruction in the brush roll or in the motor section, reinstall the filters into place and then re start. If the unit cannot be re-started, call 1-877- 531-7321 for assistance
	Battery may be depleted.	Charge the battery as instructed on page 10.
	Brush roll is jammed.	Remove obstruction. Follow instructions on page 15.



Brush roll in the motorized nozzle is not turning.	Brush roll is not installed properly	Remove obstruction. Follow instructions on page 15.
	Debris accumulates on metal contacts connecting the dust cup and the main body of the hand vacuum.	Remove obstruction. Follow instructions on page 14.
	The dust cup is installed incorrectly.	Reinstall the dust cup correctly as instructed on page 14.
	The hand vacuum and the wand are not connected into place.	Reinstall the hand vacuum and the wand correctly as instructed on page 9.
	The motorized nozzle and the wand are not connected into place.	Reinstall the motorized nozzle and the wand correctly as instructed on page 15.
	Nozzle motor and brush roll both are not turning	Check to confirm the above connections are properly made. Re-start the unit. If the nozzle motor and brush roll are still not turning, the nozzle motor may be damaged. Call 1-877-531- 7321 for assistance.
	Nozzle motor is spinning, but the brush roll is not rotating.	The belt is broken. Call 1-877-531-7321 for assistance.
Vacuum is not picking up or suction power is weak.	Dust cup is full.	Empty the dust cup.
	Filter needs cleaning	Follow filter cleaning instructions
	Filter needs to be replaced.	To purchase parts call 1-844-202-9924.
	Battery may be depleted.	Charge the battery as instructed
	Dust cup is not installed well	Check the dust cup for correct installation and ensure it is snapped firmly in place.
Dust escapes from vacuum	Filter is missing or installed incorrectly.	Check the filter for correct installation.



	Filter is damaged and needs to be replaced.	To purchase a replacement filter, call 1-844-202-9924.
	Dust cup is full or is installed incorrectly.	Empty the dust cup container or position the dust cup correctly and snap firmly into place
	Pre-filter is missing or is installed incorrectly.	Reinstall correctly as instructed
Vacuum turns off on its own.	Battery may be depleted.	Charge the battery as instructed
	Brush roll in the motorized nozzle is jammed or is not installed well causing motor protection system activated.	With the unit turned off, remove the obstruction or re-install the brush roll as instructed on page 15 and then re-start.
	Excessive loading on brush roll brush.	Remove the obstruction and then re-start
	The battery is damaged	Call 1-877-531-7321 for assistance

**Warning**

This content is compiled from multiple sources and is provided for reference purposes only. It may not be complete or fully applicable to all situations. If you are unable to resolve your issue, please contact the product manufacturer or an authorized service provider for official support.

