

Parts

Main Unit (attached power cord not shown)

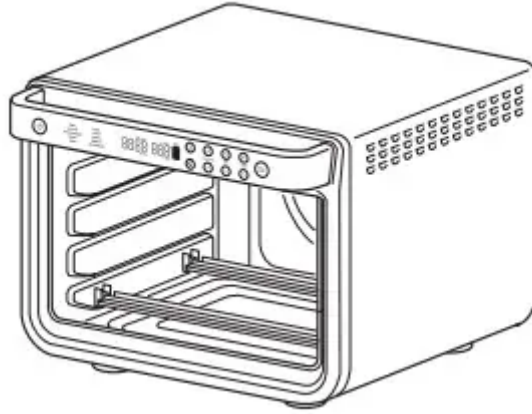

Air Fry Basket

Install when using the air fry function. Hand-wash recommended.

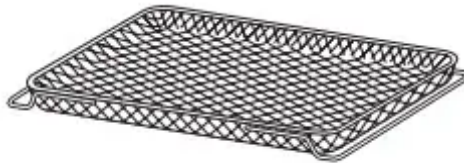

Roast Tray

its on top of the oven tray to catch grease below roasted or air fried foods to reduce smoke and grease splatter. Hand-wash only

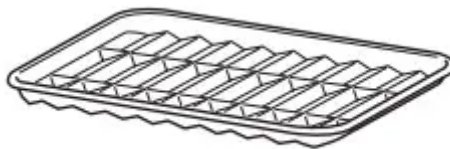

Oven Tray

Place on top of the wire rack. Hand-wash only.



2 Wire Racks

Use on its own or place the oven tray on top. Hand-wash recommended.

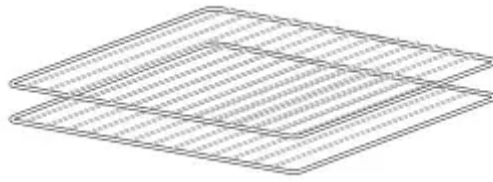

Removable Crumb Tray (already installed in unit)

Must remain installed when the oven is in use. Hand-wash only.



IMPORTANT: Place crumb tray below lower heating elements. **DO NOT** slide into any rack positions.

COMMON-SENSE PRACTICES/GOOD HABITS:

- DO NOT leave your oven unattended while making food. If possible, unplug the oven while not in use to eliminate the possibility of accidents occurring.
- Have a fire extinguisher or fire containment blanket handy in a safe, known location. If you don't have a fire extinguisher, douse the flames with bicarbonate of soda until they are put out.
- If a fire occurs and the food in the oven is not greasy, immediately unplug the unit and douse the flames with water until the fire is extinguished. **DO NOT** use water if grease is present, since it could make the fire worse. Use bicarbonate of soda instead.

Accessory Placement

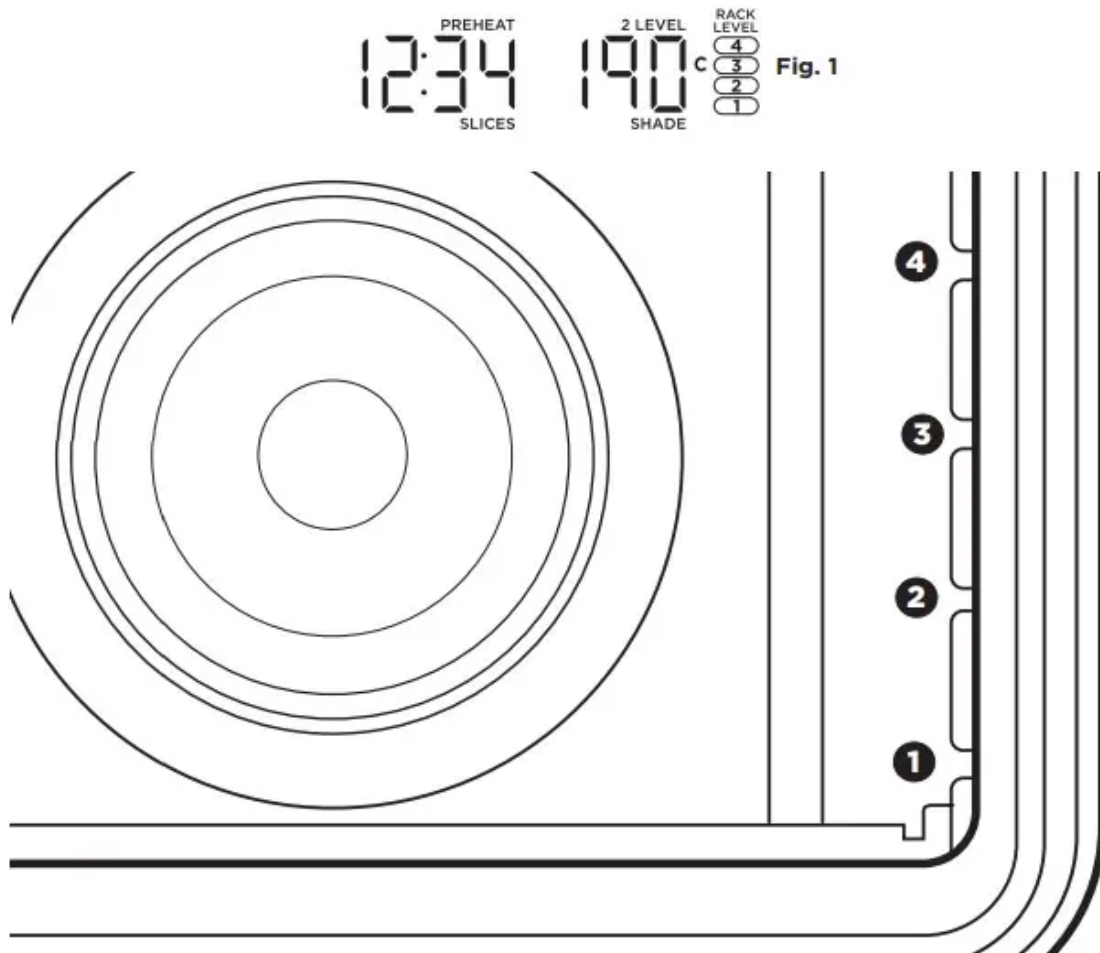

The oven has 4 available rack positions where your accessories can slide into the unit (see image above). When you select a function, the corresponding rack number(s) will illuminate on the control panel. The numbers on the control panel (see Fig. 1) will coincide with those on the interior of the unit. See the chart on page 8 for further details.

Before First Use

1. Remove and discard any packaging material, promotional labels and tape from the unit.
2. Remove all accessories from the package and read this manual carefully. Please pay particular attention to operational instructions, warnings and important safeguards to avoid any injury or property damage.
3. Wash the air fry basket, oven tray, wire rack, roasting rack and removable crumb tray in warm, soapy water, then rinse and dry thoroughly. DO NOT put oven tray, roasting rack or removable crumb tray in the dishwasher. Finishes may degrade. NEVER submerge the main unit in water.

NOTE: The accessories are hand-wash recommended. The air fry basket and wire racks can be put in the dishwasher, but may wear more quickly over time.

Using the Control Panel



Functions

Once you've selected a function below, you can change temperature/shade and time/slices.

GRILL: Evenly grill meats, fish and brown the tops of casseroles.

AIR FRY: Foods that would traditionally be fried—such as chicken wings, French fries and chicken nuggets—with little to no added oil.

WHOLE ROAST: Simultaneously roast large proteins, like a 2.25kg chicken and sides, for a complete meal. Or cook a larger protein, like a 5.4kg turkey, on its own.

ROAST: Achieve a crispy outside and perfectly cooked inside for full-sized oven tray meals, thicker proteins and roasted veggies.

BAKE: Evenly bake everything from your favourite cookies to cakes.

PIZZA: Cook frozen or homemade pizzas evenly.

TOAST: Toast up to 8 slices of bread to your desired level of darkness.

BAGEL: Perfectly toast up to 8 bagel halves when they're placed cut-side up on the wire rack.

REHEAT: Heat leftovers without over cooking.

DEHYDRATE: Dehydrate meats, fruits and vegetables for healthy snacks.

NOTE: The oven's technology leads to faster cooking. Always monitor food to prevent overcooking. Refer to cook charts in the Recipe Guide for more guidance on cook times and temperatures.

Control Panel Display & Operating Buttons

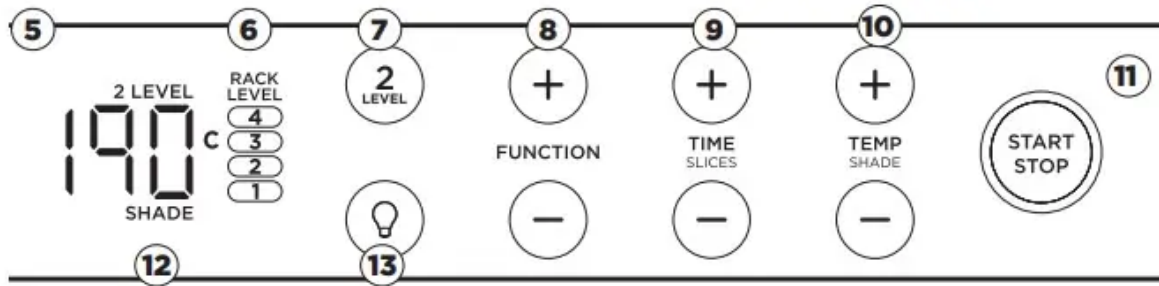

1.  (Power) button: Press to turn the unit on and off.
2. Time display: Shows the cook time. The time will count down when cooking is in progress.
3. PREHEAT: Flashes when the unit is preheating. If the oven is already up to temperature from using a previous cooking function, the unit will skip preheating.
4. SLICES: Illuminates when using the Toast or Bagel function to designate number of slices.
5. Temperature display: Shows the cook temperature.
6. RACK LEVEL: Depending on the function you choose, the illuminated rack level(s) will indicate where your accessory should be placed in the unit.
7. 2 LEVEL: For functions that allow you to cook on 2 levels, press the button to select 2-level cooking and rack levels will update.
8. FUNCTION +/- buttons: To select a cooking function, press the FUNCTION +/- buttons. 6 ninjakitchen.co.uk USING THE CONTROL PANEL GRILL: Evenly grill meats, fish and brown the tops of casseroles. AIR FRY: Foods that would traditionally be fried—with little to no added oil. WHOLE ROAST: Simultaneously roast large proteins, like a 2.25kg chicken and sides, for a complete meal. Or cook a larger protein, like a 5.4kg turkey, on its own. ROAST: Achieve a crispy outside and perfectly cooked inside for full-sized oven tray meals, thicker proteins and roasted veggies. BAKE: Evenly bake everything from your favourite cookies to cakes.
9. TIME/SLICES +/- buttons: To select a cook time, press the TIME +/- buttons. When using the Toast or Bagel function, these buttons will adjust the number of slices/bagel halves instead of the time. If cooking for 1 hour or less, the clock will count down by minutes and seconds. If cooking for more than 1 hour, the clock will count down by hours and minutes. Hold the +/- buttons for 2 seconds to activate faster scrolling in 5-minute increments.
10. TEMP/SHADE +/- buttons: To adjust temperature, press the TEMP +/- buttons. When using the Toast or Bagel function, these buttons will adjust the shade level (1, lightest –

7, darkest) instead of the temperature. Temperature will increase in 5-degree increments. Hold the +/- buttons for 2 seconds to activate faster scrolling in 10-degree increments.

11. START/STOP button: Press to start or stop cooking.

12. SHADE: Illuminates when using the Toast or Bagel function to designate desired shade.

13.  (Light) button: Press to turn the oven's interior light on and off.

Using Your Ninja® Foodi® Oven

When to Use the Roast Tray.

Use Roast Tray on Oven Tray when cooking on convection functions (such as Whole Roast, Roast and Air Fry) or with greasy foods like: whole chicken, chicken wings, bacon, marinated meats or oiled vegetables.



Recommended for

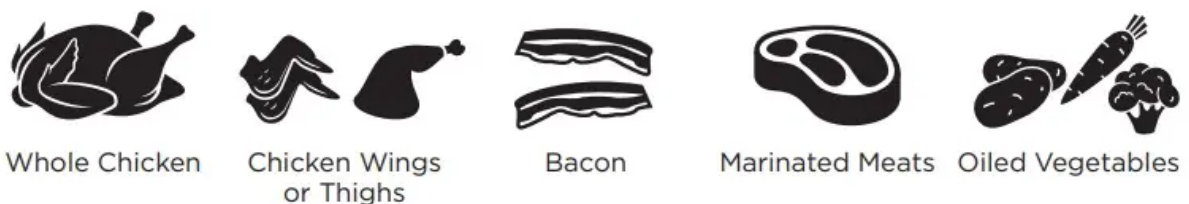

Using the Cooking Functions with Rack Levels

When you select a cooking function, the control panel will illuminate the recommended rack height(s). The chart below outlines these recommendations along with the suggested accessories. For best results, use only the recommended accessories for a given function and remove others from the oven.

	WHOLE ROAST		ROAST		AIR FRY		BAKE	
	1 Layer	2 Layers	1 Layer	2 Layers	1 Layer	2 Layers	1 Layer	2 Layers
LEVEL 4		Air Fry Basket				Air Fry Basket		
LEVEL 3			Roast Tray on Oven Tray	Air Fry Basket	Air Fry Basket		Oven Tray on Wire Rack	Accessory on Wire Rack
LEVEL 2						Roast Tray on Oven Tray		
LEVEL 1	Roast Tray on Oven Tray	Roast Tray on Oven Tray		Roast Tray on Oven Tray	Roast Tray on Oven Tray			Accessory on Wire Rack

NOTE: When cooking greasy, drippy foods on one level, place the Oven Tray on the Wire Rack below to catch the drippings. Alternatively, use the Roast Tray on top of the Oven Tray

DEHYDRATE		GRILL	TOAST	BAGEL	REHEAT	PIZZA	
1 Layer	2 Layers	1 Layer	1 Layer	1 Layer	1 Layer	1 Layer	2 Layers
	Air Fry Basket						
Air Fry Basket		Roast Tray on Oven Tray	Wire Rack	Wire Rack	Wire Rack	Wire Rack	Wire Rack
	Oven Tray						
							Wire Rack

NOTE: Always place Oven Tray on Wire Rack, DO NOT place directly on heating elements.

How to Reduce Smoke

We recommend using vegetable, sunflower, refined coconut, avocado, rapeseed or grapeseed oil instead of olive oil.

Recommended:



Vegetable

Sunflower

Refined coconut

Avocado

Rapeseed

Grapeseed

Not recommended:



Olive oil Butter Margarine

The unit may produce smoke when cooking on a hotter setting than recommended

NOTE: For more cooking charts, refer to your recipe guide

Using the Cooking Functions

To turn on the unit, plug the power cord into an electrical socket and press the  button. The unit will automatically shut off after 10 minutes of inactivity.

Grill

NOTE: The unit does not preheat in Grill mode

1. To select the function, press the function +/- buttons until GRILL brightly illuminates. The default time and temperature settings will display.
2. Press the TIME/SLICES +/- buttons to select a cook time up to 30 minutes.
3. Press the TEMP/SHADE +/- buttons to select either HI or LO.
4. Place ingredients on the oven tray. Place the oven tray on the wire rack and close the oven door, press START/STOP to start cooking.
5. When cook time is complete, the unit will beep and "END" will appear on the display

Air Fry

1. To select the function, press the function +/- buttons until AIR FRY brightly illuminates. The default time and temperature settings will display. When cooking 2 layers, select the 2 LEVEL button so that "2 LEVEL" appears on the display.
2. Press the TIME/SLICES +/- buttons to select a cook time up to 4 hours.

3. Then press the TEMP/SHADE +/- buttons to select a temperature between 120°C and 230°C.
4. Press START/STOP to begin preheating.
NOTE: Food cooks faster when using the Air Fry function. Refer to Air Fry Chart in the Recipe Guide for more guidance
5. Place ingredients in the air fry basket and roast tray with oven tray. If ingredients are fatty, oily or marinated, place the basket on the oven tray. Use air fry basket for dry ingredients.
6. When the unit beeps to signify it has preheated, immediately slide the basket into the rack level(s) designated on the control panel. If also using the oven tray, slide both into the oven at the same time, with the basket in the upper rack and the pan on the wire rack beneath the basket. Close oven door.
7. When cook time is complete, the unit will beep and “END” will appear on the display
NOTE: The timer will start counting down as soon as the unit has preheated. If ingredients are not ready to go into the oven, simply press the TIME +/- buttons to add more time.

Whole Roast

1. To select the function, press the function +/- buttons until WHOLE ROAST brightly illuminates. The default time and temperature settings will display. When cooking 2 layers, select the 2 LEVEL button so that “2 LEVEL” appears on the display.
2. Press the TIME/SLICES +/- buttons to select a cook time up to 4 hours.
NOTE: If cooking for 1 hour or less, the clock will count down in minutes and seconds. If cooking for more than 1 hour, the clock will count down in hours and minutes.
3. Press the TEMP/SHADE +/- buttons to select a temperature between 120°C and 230°C.
4. Press START/STOP to begin preheating.
NOTE: Food cooks faster when using the Whole Roast function so refer to cook charts in the Recipe Guide for more guidance on cook times and temperatures.
5. Place ingredients on the roast tray or directly on oven tray. When the unit beeps to signify it has preheated, immediately place roast tray on the oven tray on the wire rack on Level 1. Close oven door. When cooking on 2 levels, place the oven tray on Level 1 and use the air fry basket as the second layer on Level 4.
NOTE: The timer will start counting down as soon as the unit has preheated. If ingredients are not ready to go into the oven, simply press the TIME +/- buttons to add more time.
6. When cook time is complete, the unit will beep and “END” will appear on the display

Roast

1. To select the function, press the function +/- buttons until ROAST brightly illuminates. The default time and temperature settings will display. When cooking 2 layers, select the 2 LEVEL button so that "2 LEVEL" appears on the display.
2. Press the TIME/SLICES +/- buttons to select a cook time up to 4 hours.
NOTE: If cooking for 1 hour or less, the clock will count down in minutes and seconds. If cooking for more than 1 hour, the clock will count down in hours and minutes.
3. Press the TEMP/SHADE +/- buttons to select a temperature between 120°C and 230°C.
4. Press START/STOP to begin preheating.
NOTE: Food cooks faster when using the Roast function, so refer to cook charts in the Recipe Guide for more guidance on cook times and temperatures.
5. Place ingredients on the oven tray. When the unit beeps to signify it has preheated, immediately place the roast tray on oven tray on the wire rack on Level 1. Close oven door. When cooking on 2 levels, place the oven tray on Level 1 and use the air fry basket as the second layer on Level 3.
NOTE: The timer will start counting down as soon as the unit has preheated. If ingredients are not ready to go into the oven, simply press TIME +/- buttons to add more time.
6. When cook time is complete, the unit will beep and "END" will appear on the display

Bake.

1. To select the function, press the function +/- buttons until BAKE brightly illuminates. The default time and temperature settings will display. When cooking 2 layers, select the 2 LEVEL button so that "2 LEVEL" appears on the display.
2. Press the TIME/SLICES +/- buttons to select a cook time up to 4 hours.
NOTE: If cooking for 1 hour or less, the clock will count down in minutes and seconds. If cooking for more than 1 hour, the clock will count down in hours and minutes.
3. Press the TEMP/SHADE +/- buttons to select a temperature between 80°C and 230°C.
4. Press START/STOP to begin preheating.
5. Place ingredients on the oven tray. Other baking tins can be used instead of the oven tray if preferred. When the unit beeps to signify it has preheated, immediately place the oven tray on the wire rack. Close oven door.
NOTE: The timer will start counting down as soon as the unit has preheated. If ingredients are not ready to go into the oven, simply press the TIME +/- buttons to add more time.
6. During cooking, you can turn on the light  to check on progress.

7. When cook time is complete, the unit will beep and “END” will appear on the display.

NOTE: For best results with baked goods such as cookies, line the oven tray with baking paper.

Pizza

1. To select the function, press the function +/- buttons until PIZZA brightly illuminates. The default time and temperature setting will display.
2. Press the TIME/SLICES +/- buttons to select a cook time up to 4 hours.
3. Press the TEMP +/- buttons to select a temperature between 80°C and 230°C.
4. Place pizza on the oven tray or directly on the wire rack. Close oven door and press START/STOP to begin cooking.
5. When cook time is complete, the unit will beep and “END” will appear on the display.

Toast

NOTE: The unit does not preheat in Toast mode.

1. To select the function, press the function +/- buttons until TOAST brightly illuminates. The default amount of slices and darkness level will display.
2. Press the TIME/SLICES +/- buttons to select the number of bread slices. You may toast up to 9 slices at once.
3. Press the TEMP/SHADE +/- buttons to select a darkness level.

NOTE: There is no temperature adjustment available for the Toast function and the unit does not preheat in Toast mode. It is very important to select the exact number of slices to avoid over- or under-toasting.

4. Place bread slices on the wire rack. Close oven door and press START/STOP to begin cooking.
5. When cook time is complete, the unit will beep and “END” will appear on the display

NOTE: You can also manually adjust the time once cooking has started to better choose your preferred shade.

Bagel

NOTE: The unit does not preheat in Bagel mode.

1. To select the function, press the function +/- buttons until BAGEL brightly illuminates. The default number of slices and darkness level will display.
2. Press the TIME/SLICES +/- buttons to select the number of slices. You may toast up to 9 bagel slices at once.
3. Press the TEMP +/- buttons to select a darkness level.

NOTE: There is no temperature adjustment available for the Bagel function and the unit does not preheat in Bagel mode. It is very important to select the exact number of slices to avoid over- or under-toasting.

4. Place bagel slices, cut-side up, in the middle of the wire rack. Close oven door and press START/STOP to begin cooking.
5. When cook time is complete, the unit will beep and “END” will appear on the display.
NOTE: You can also manually adjust the time once cooking has started to better choose your preferred shade.

Reheat

NOTE: The unit does not preheat in Reheat mode.

1. To select the function, press the function +/- buttons until REHEAT brightly illuminates.
2. Press the TIME/SLICES +/- buttons to select a reheat time up to 4 hours.
3. Press the TEMP/SHADE +/- buttons to select a temperature between 40°C and 230°C.
4. Place food on the oven tray or in an oven-safe container and place the pan or container on the wire rack. Close oven door and press START/STOP to begin warming.
5. When cook time is complete, the unit will beep and “END” will appear on the display

Dehydrate

NOTE: The unit does not preheat in Dehydrate mode

1. To select the function, press the function +/- buttons until DEHYDRATE brightly illuminates. The default time and temperature settings will display. When dehydrating 2 layers, select the 2 LEVEL button so that “2 LEVEL” appears on the display.
2. Press the TIME/SLICES +/- buttons to select a dehydrate time up to 24 hours.
3. Press the TEMP/SHADE +/- buttons to select a temperature between 30°C and 90°C.
4. Place ingredients in the air fry basket and place basket in oven. Close oven door and press START/STOP to begin cooking
NOTE: For best results, lay ingredients flat on each layer; do not stack food.
5. When cook time is complete, the unit will beep and “END” will appear on the display

Cleaning & Maintenance

Everyday Cleaning

The unit should be cleaned thoroughly after every use.

1. Unplug the unit from the socket and allow it to cool down before cleaning.

2. Empty crumb tray by sliding it out of the oven.

NOTE: Empty crumb tray frequently. Hand-wash when necessary.

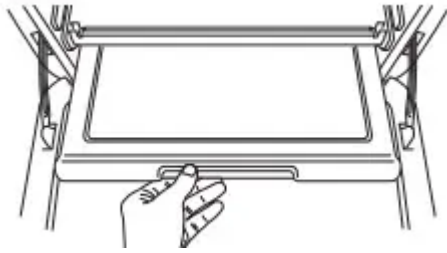

3. After every use, wipe away any food splatter on the interior walls and glass door of the unit with a soft, damp sponge.
4. To clean the exterior of the main unit and the control panel, wipe them clean with a damp cloth. A non-abrasive liquid cleanser or mild spray solution may be used. Apply the cleanser to the sponge, not the oven surface, before cleaning.
5. When using accessories, we recommend greasing them with recommended cooking oil or covering them with parchment paper or aluminum foil before placing food on top. **DO NOT** cover roast tray holes with parchment paper or aluminum foil.

Deep Cleaning

1. Unplug the unit from the socket and allow it to cool down before cleaning.
2. Remove all accessories from the unit, including the crumb tray and wash separately. Use a non-abrasive cleaning brush to more thoroughly wash the air fry basket. Accessories are hand-wash recommended. The air fry basket and wire racks can be put in the dishwasher, but may wear more quickly over time. **DO NOT** place roast tray, oven tray or crumb tray in dishwasher.
3. Use warm, soapy water and a soft cloth to wash the oven's interior and glass door, **DO NOT** use abrasive cleaners, scrubbing brushes or chemical cleaners, as they will damage the oven.
CAUTION: NEVER put the main unit in the dishwasher or immerse it in water or any other liquid.
4. To remove tough grease, let oven tray and roast tray soak overnight in warm, soapy water, then wash with a nonabrasive sponge or brush.
5. Thoroughly dry all parts before placing them back in the oven.



IMPORTANT: Place crumb tray below lower heating elements. DO NOT slide into any rack positions.

Troubleshooting & FAQ

ERROR MESSAGES

“CALL CUST SrVC” followed by “Er0,” “Er1,” “Er2,” “Er3,” “Er4,” “Er5,” or “Er6” Turn off the unit and call Customer Service at 0800 862 0453

FAQ

- Why won't the oven turn on?
 - Make sure the power cord is securely plugged into the socket. Insert the power cord into a different socket.
 - Reset the circuit breaker if necessary.
 - Press the power button.

- Can I use the oven tray instead of the air fry basket with Air Fry function?
 - Yes, but crispiness results may vary.
- Do I need to adjust the cook times and temperatures of traditional oven recipes?
 - For best results, keep an eye out on your food while cooking. Refer to cook charts in the Recipe Guide for more guidance on cook times and temperatures.
- Can I restore the unit to its default settings?
 - The oven will remember the last setting used for each function, even if you unplug it. To restore the oven's default settings for each function, press the Light and 2 LEVEL buttons simultaneously for 5 seconds.
- Why do the heating elements appear to be turning on and off?
 - This is normal. The oven is designed to control temperature precisely for every function by adjusting the heating elements' power levels.
- Why does the oven have a different temperature reading with an external thermometer?
 - Convection ovens circulate air differently than traditional ovens, so when the door is opened, more heat will escape. This may affect any external temperature reading of the unit's interior temperature.
 - Since this is a convection oven, it can cook more quickly than a traditional oven. Convection cooking includes a fan that helps speed up cook time by circulating hot air and can affect temperatures within the cavity. The time it takes the unit to heat up to the set temperature will vary based on the amount of food being cooked, the function being used and the cook temperature and time. The oven features an algorithm that ensures temperature and time settings work with most traditional oven recipes. As a result, the temperature inside the oven may differ from the set temperature. This does not impact cooking quality. Refer to the Recipe Guide to learn more about recommended cook times and temperatures.
- Why is my unit not fully preheated when the preheat cycle is completed?
 - During preheating, the unit will not reach the intended cook temperature, but it will preheat to a level that will start cooking your ingredients. As the cook cycle continues, the oven will continue to heat up and cook your food to doneness. It may take up to 10 minutes for the unit to reach the intended cook temperature. This does not affect the cooking quality of most recipes.
- Why is steam coming out from the oven door?
 - This is normal. Foods with a high moisture content may release steam around the door.

- Why is water dripping onto the worktop from under the door?
 - This is normal. The condensation created by foods with a high moisture content (such as frozen breads) may run down the inside of the door and drip onto the worktop
- Why is the unit generating smoke?
 - Ensure you are using the roast tray on the oven tray when cooking all greasy foods or when using Air Fry, Roast or Whole Roast functions.
 - If problem persists, run a Toast cycle on shade 7 with accessories removed; this will burn off any additional grease on the heating elements that are causing smoke.
- How can I clean the oven tray?
 - For stuck-on food, let the oven tray soak before cleaning.
 - Line the oven tray with aluminum foil or parchment paper when cooking to make clean-up easier.
- Why does the unit sound like it is still running even though the power is off?
 - The cooling fan may continue to run even after the unit has been turned off. This is a normal function and should not be a source of concern. The cooling fan will stop after the temperature of the unit reaches below 35°C

Accessories for Purchase

We offer range of accessories for your Ninja® Foodi® 10-in-1 Multifunction Oven



• Silicone Mitts

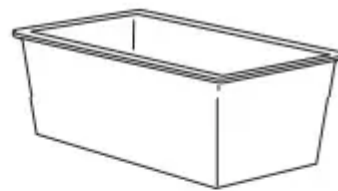

• Loaf Tin



• 12-Cup Muffin Tin



• Tube Pan

Warning

This content is compiled from multiple sources and is provided for reference purposes only. It may not be complete or fully applicable to all situations. If you are unable to resolve your issue, please contact the product manufacturer or an authorized service provider for official support.

Document generated by [ManualsFile](#)