

Operation Guide

Instrument

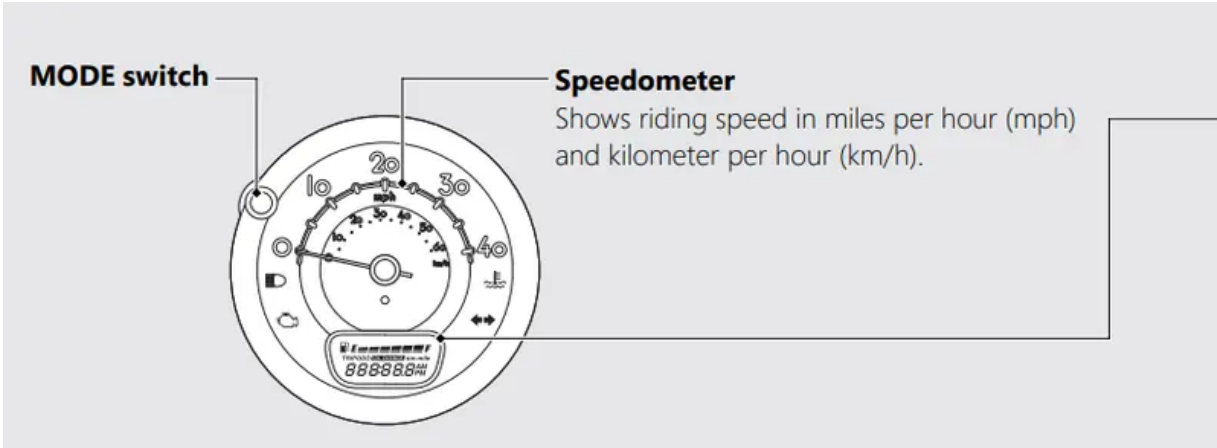

Display Check

When the ignition switch is turned to the ON position, the speedometer needle swings to the maximum scale on the dial once, all the mode and digital segments will show. If any part of these displays does not come on when it should, have your dealer check for problems.

Fuel gauge
Remaining fuel when only 1st (E) segment starts flashing: approximately 0.394 US gal (1.45 L)

Odometer [ODO] & Tripmeter [TRIP] & Clock (12-hour display)
MODE switch selects the odometer, tripmeter and clock.

- Odometer: Total distance ridden.
- Tripmeter: Distance ridden since tripmeter was reset (press and hold MODE switch to reset to 0.0 miles (0.0 km)).

To set the clock: ➔ P.22

Odometer **Tripmeter** **Clock**

ODO 150 TRIP 150.0 10:25 AM

➔ Press the MODE switch

If the fuel gauge indicator flashes in a repeat pattern or turns off: ➔ P.82

Display Setting

You can adjust the following settings.

- Clock setting
- Changing of mileage unit

To set the clock:

1. Turn the ignition switch to the ON position.
2. Select the clock display. (P.21)
3. Press and hold the MODE switch until the hour digits start flashing.



4. Press the MODE switch until the desired hour and AM/PM are displayed.



5. Press and hold the MODE switch until the minute digits start flashing.



6. Press the MODE switch until the desired minute is displayed.



7. Press and hold the MODE switch. The clock is set.

- The time can also be set by turning the ignition switch to the OFF position.
- The display will stop flashing automatically and the adjustment will be canceled if the button is not pressed for about 30 seconds.

Changing the mileage unit:

1. Turn the ignition switch to the ON position.
2. Select the odometer display. (P.21)
3. Press and hold the MODE switch to select the "mile" or "km".

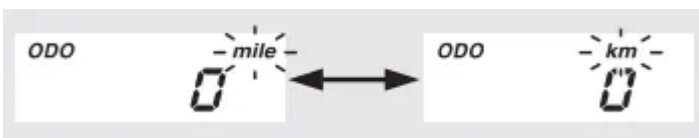

Maintenance

Maintenance Fundamentals

Pre-ride Inspection

To ensure safety, it is your responsibility to perform a pre-ride inspection and make sure that any problem you find is corrected. A pre-ride inspection is a must, not only for safety, but because having a breakdown, or even a flat tire, can be a major inconvenience.

Check the following items before you get on your vehicle:

- Tire tread wear and air pressures are within limits. **P. 60**
- Lights, horn, and turn signals operate normally.

Check the following items if you are carrying a cargo:

- Combined weight is within load limits. **P. 114**
- Cargo is secured properly.

Check the following items after you get on your vehicle:

- Throttle action moves smoothly without binding. **P. 77**
- Brake levers operate normally.
- Check the fuel level and refuel when needed. **P. 12, P. 37**
- Engine stop switch functions properly. **P. 26**

Check the following items at regular intervals:

- Oil level is between the upper and lower level marks. **P. 68**
- Engine coolant level is between the UPPER and LOWER level marks. **P. 70**
- Rear brake lock works properly. **P. 30**

Periodic Checks

You should also perform other periodic maintenance checks at least once a month regardless of how often you ride, or more often if you ride frequently.

Also, check the odometer reading against the Maintenance Schedule and perform all maintenance that is due. **P. 47**

Tires and wheels

- Check the air pressure (P. 60), examine tread for wear and damage (P. 60), and check the wheels for damage.

Fluid levels

- Check the engine oil level (P. 68) and engine coolant level (P. 70).

Lights

- Check that the headlight, brake light, taillight, and turn signals are working properly.

Controls

- Check the freeplay of the front and rear brake levers (P. 72), and throttle grip (P. 77).

Fuses

- Check that you have a full supply of spare fuses.

Nuts & bolts

- Check the major nuts and bolts, and tighten as needed.

Replacing Parts

Always use Honda Genuine Parts or their equivalents to ensure reliability and safety. When ordering colored components, specify the model name, color, and code mentioned on the color label.

The color label is attached to the center compartment under the seat. **P. 39**

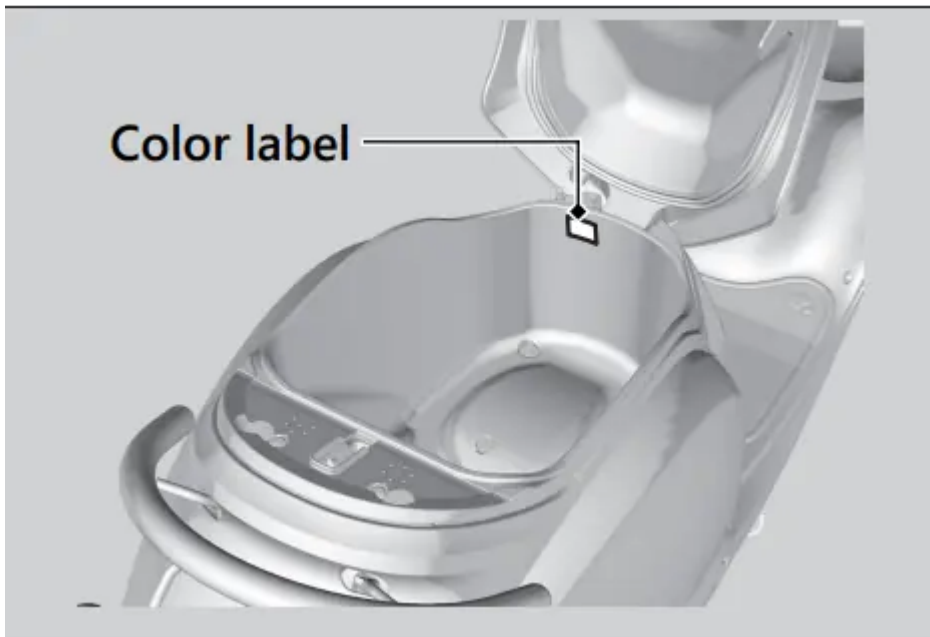

WARNING

Installing non-Honda parts may make your vehicle unsafe and cause a crash in which you can be seriously hurt or killed. Always use Honda Genuine Parts or equivalents that have been designed and approved for your vehicle.

Battery

Your vehicle has a maintenance-free type battery. You do not have to check the battery electrolyte level or add distilled water. Clean the battery terminals if they become dirty or corroded.

Do not remove the battery cap seals. There is no need to remove the cap when charging.

NOTICE

An improperly disposed of battery can be harmful to the environment and human health.

Always confirm local regulations for proper battery disposal instruction

What to do in an emergency

If any of the following occur, immediately see your doctor.

- Electrolyte splashes into your eyes:
 - Wash your eyes repeatedly with cool water for at least 15 minutes. Using water under pressure can damage your eyes.
- Electrolyte splashes onto your skin:
 - Remove affected clothing and wash your skin thoroughly using water.
- Electrolyte splashes into your mouth:
 - Rinse mouth thoroughly with water, and do not swallow

WARNING: Battery posts, terminals, and related accessories contain lead and lead compounds.

Wash your hands after handling.

Cleaning the Battery Terminals

1. Remove the battery. **P. 64**
2. If the terminals are starting to corrode and are coated with a white substance, wash with warm water and wipe clean.
3. If the terminals are heavily corroded, clean and polish the terminals with a wire brush or sandpaper. Wear safety glasses.

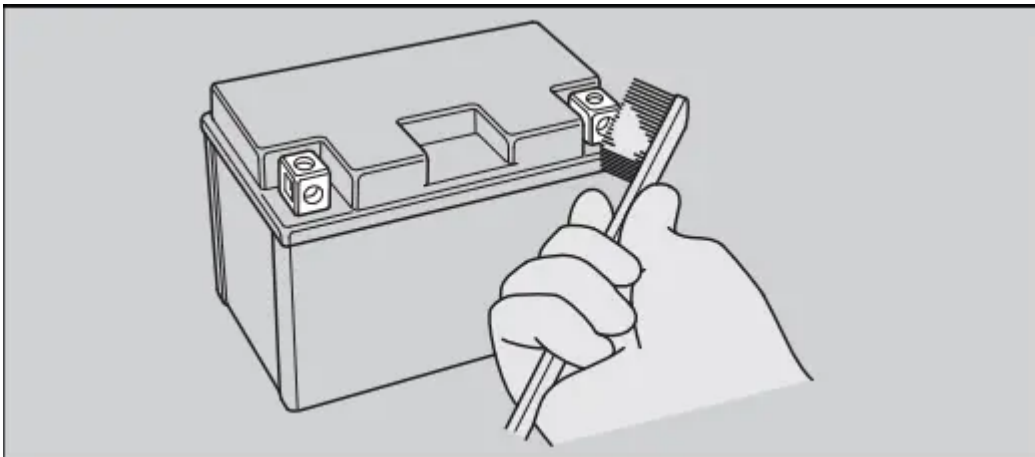

4. After cleaning, reinstall the battery.

The battery has a limited life span. Consult your dealer about when you should replace the battery. Always replace the battery with another maintenance-free battery of the same type.

Charging

If you use electrical accessories that drain the battery or you do not ride frequently, we recommend that you charge the battery every 30 days using a charger designed specifically for your Honda, which can be purchased from your dealer. Read the information that came with your battery charger and follow the instructions on the battery. Avoid using an automobile-type battery charger, as these can overheat a motorcycle battery and cause permanent damage.

Make sure the ignition switch is in the OFF position before charging the battery.

NOTICE Improper charging can damage the battery. If you can't charge the battery or it appears unable to hold a charge, contact your dealer.

NOTICE Jump starting using an automobile battery can damage your vehicle's electrical system and is not recommended. Bump starting is also not recommended.

NOTICE Installing non-Honda electrical accessories can overload the electrical system, discharging the battery and possibly damaging the system.

Fuses

Fuses protect the electrical circuits on your vehicle. If something electrical on your vehicle stops working, check for and replace any blown fuses. P. 89

Inspecting and Replacing Fuses

Turn the ignition switch to the OFF position to remove and inspect fuses. If a fuse is blown, replace with a fuse of the same rating. For fuse ratings, see "Specifications." P. 115

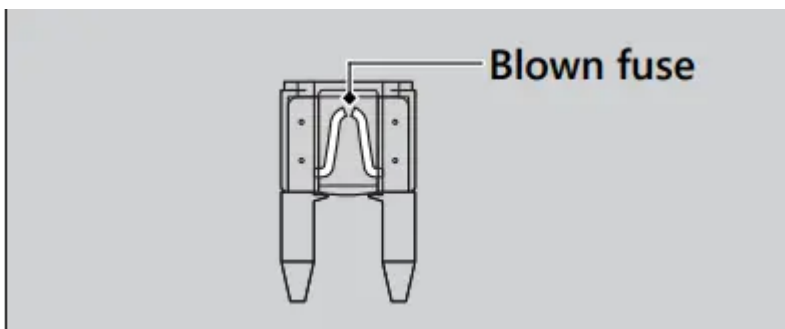

NOTICE Replacing a fuse with one that has a higher rating greatly increases the chance of damage to the electrical system.

If a fuse fails repeatedly, you likely have an electrical fault. Have your vehicle inspected by your dealer.

Engine Oil

Engine oil consumption varies and oil quality deteriorates according to riding conditions and time elapsed.

Check the engine oil level regularly, and add the recommended engine oil if necessary. Dirty oil or old oil should be changed as soon as possible.

Selecting the Engine Oil

For recommended engine oil, see “Specifications.” P. 115 If you use non-Honda engine oil, check the label to make sure that the oil satisfies all of the following standards:

- JASO T 903 standard*1: MB
- SAE standard*2: 10W-30
- API classification*3: SG or higher

*1. The JASO T 903 standard is an index for engine oils for 4-stroke motorcycle engines. There are two classes: MA and MB. For example, the following label shows the MB classification.

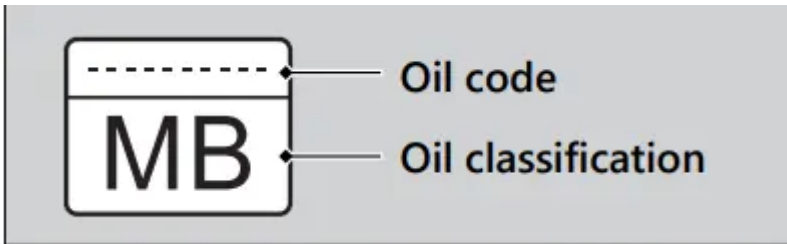

*2. The SAE standard grades oils by their viscosity.

*3. The API classification specifies the quality and performance rating of engine oils. Use SG or higher oils, excluding oils marked as “Energy Conserving” or “Resource Conserving” on the circular API service symbol.

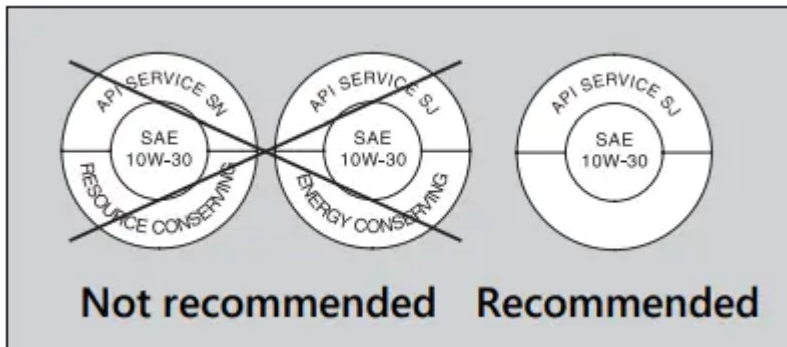

Recommended Coolant

Pro Honda HP Coolant is a pre-mixed solution of antifreeze and distilled water.

Concentration: 50% antifreeze and 50% distilled water

A concentration of antifreeze below 40% will not provide proper corrosion and cold temperature protection.

A concentration of up to 60% will provide better protection in colder climates.

NOTICE

Using coolant not specified for aluminum engines or tap/mineral water can cause corrosion.

Crankcase Breather

Service more frequently when riding in rain, at full throttle, or after the vehicle is washed or overturned. Service if the deposit level can be seen in the transparent section of the drain tube.

If the drain tube overflows, the air filter may become contaminated with engine oil causing poor engine performance.

Tires (Inspecting/Replacing)

Checking the Air Pressure

Visually inspect your tires and use an air pressure gauge to measure the air pressure at least once a month or any time you think the tires look low. Always check air pressure when your tires are cold.

Inspecting for Damage

Inspect the tires for cuts, slits, or cracks that exposes fabric or cords, or nails or other foreign objects embedded in the side of the tire or the tread. Also inspect for any unusual bumps or bulges in the side walls of the tires.

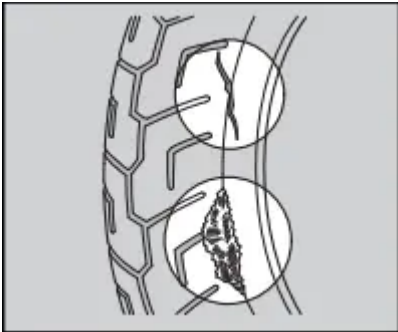

Inspecting for Abnormal Wear

Inspect the tires for signs of abnormal wear on the contact surface.

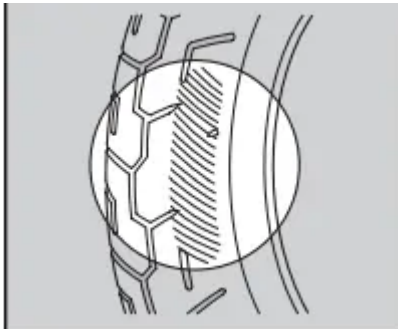

Inspecting Tread Depth

Inspect the tread wear indicators. If they become visible, replace the tires immediately

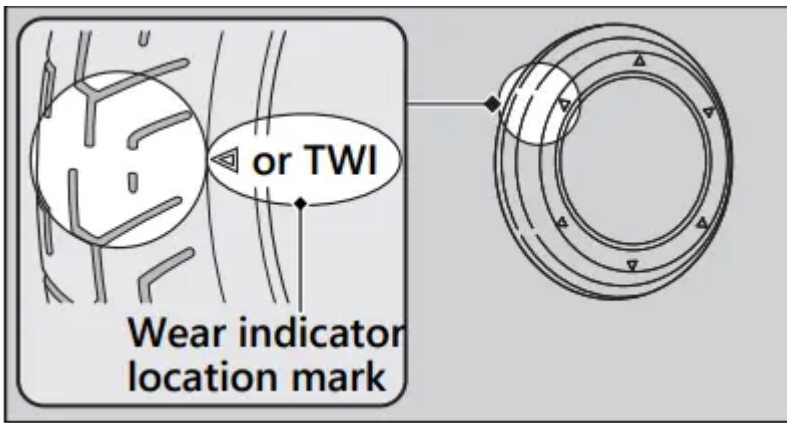

WARNING Riding on tires that are excessively worn or improperly inflated can cause a crash in which you can be seriously hurt or killed. Follow all instructions in this owner's manual regarding tire inflation and maintenance.

Have your tires replaced by your dealer. For recommended tires and air pressure, see "Specifications." P. 115 Follow these guidelines whenever you replace tires.

- Use the recommended tires or equivalents of the same size, construction, speed rating, and load range.
- Do not install a tube inside a tubeless tire on this vehicle. Excessive heat build-up can cause the tube to burst.
- Use only tubeless tires on this vehicle. The rims are designed for tubeless tires, and during hard acceleration or braking, a tubetype tire could slip on the rim and cause the tire to rapidly deflate.

Removing & Installing Body Components

Battery

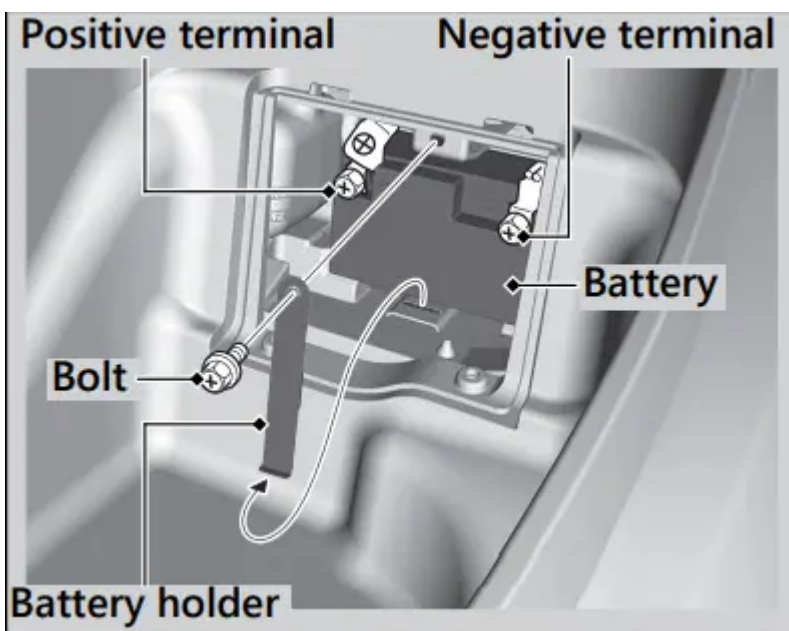

Removal

Make sure the ignition switch is in the OFF position.

1. Remove the battery lid. P. 65
2. Remove the battery holder by removing the bolt.
3. Disconnect the negative - terminal from the battery.
4. Disconnect the positive + terminal from the battery.
5. Remove the battery taking care not to drop the terminal nuts.

Installation

Install the parts in the reverse order of removal. Always connect the positive + terminal first. Make sure that bolts and nuts are tight.

Make sure the clock information is correct after the battery is reconnected. P. 22 For proper handling of the battery, see "Maintenance Fundamentals." P. 54 "Battery Goes Dead." P. 84

Battery Lid

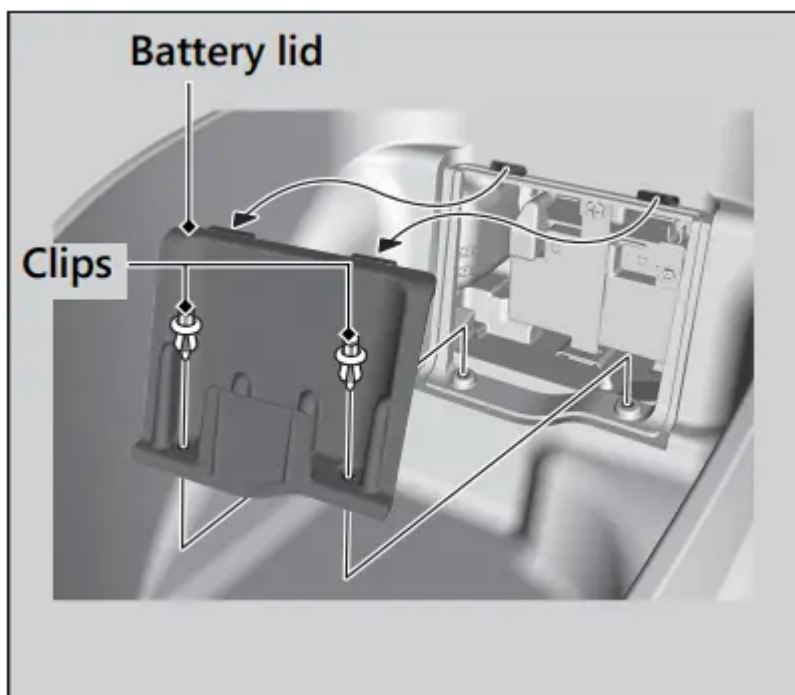

Removal

1. Open the seat. P. 39
2. Remove the clips. P. 66
3. Remove the battery lid.

Installation

Install the parts in the reverse order of removal.

Clip

Removal

1. Press down on the center pin to release the lock.
2. Pull the clip out of the hole.

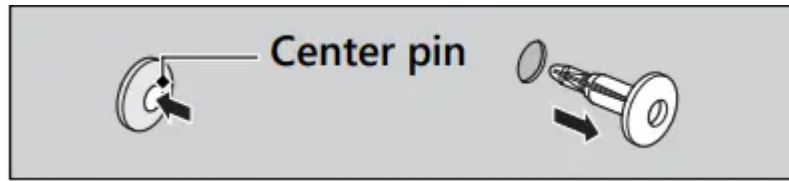

Installation

1. Push the bottom of the center pin.



2. Insert the clip into the hole.
3. Press down on the center pin to lock the clip.

Maintenance Cover

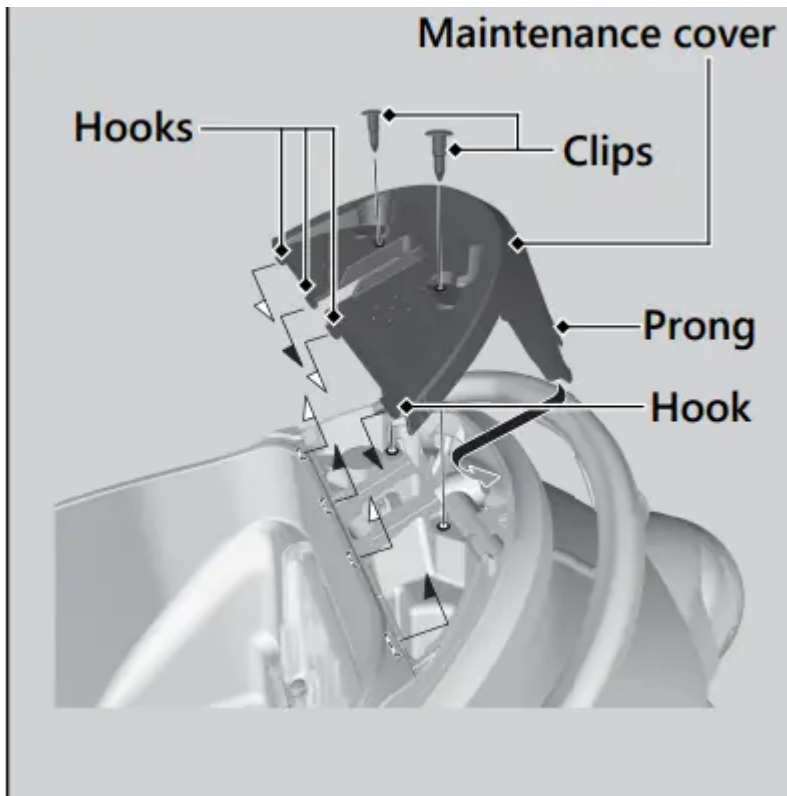

Removal

1. Open the seat. P. 39
2. Remove the clips. P. 66

3. Remove the hooks.

- Remove the outside hooks at first, then remove the inside hooks.

4. Remove the maintenance cover by lifting it and removing the prongs from the body cover.

Installation

Install the parts in the reverse order of removal.

Checking the Engine Oil

1. Place your vehicle on its center stand on a firm, level surface.
2. If the engine is cold, idle the engine for 3 to 5 minutes.
3. Turn the ignition switch to the OFF position and wait for 2 to 3 minutes.
4. Remove the oil fill cap/dipstick and wipe it clean.
5. Insert the oil fill cap/dipstick until it seats, but don't screw it in.
6. Check that the oil level is between the upper level and lower level marks on the oil fill cap/dipstick.
7. Securely install the oil fill cap/dipstick.

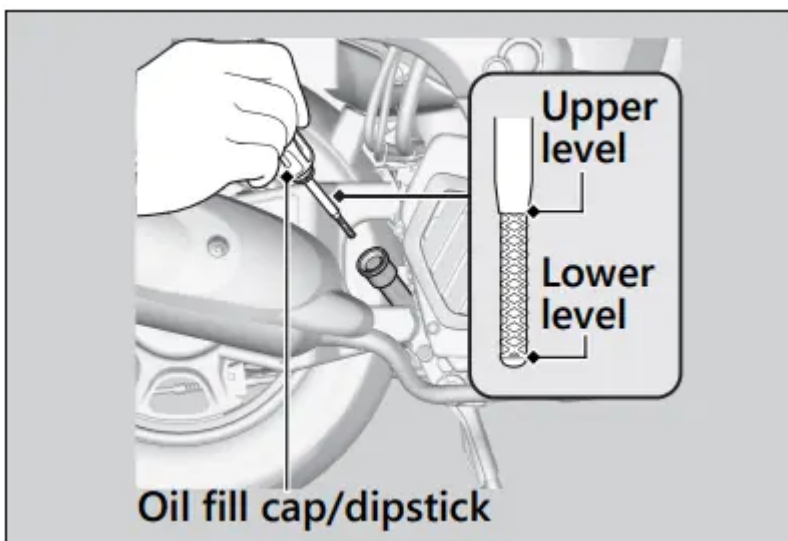

NOTICE Do not remove the dipstick while the engine is running.

Adding Engine Oil

If the engine oil is below or near the lower level mark, add the recommended engine oil. P. 58, P. 115

1. Remove the oil fill cap/dipstick. Add the recommended oil until it reaches the upper level mark.
 - Place your vehicle on its center stand on a firm, level surface when checking the oil level.
 - Do not overfill above the upper level mark.
 - Make sure no foreign objects enter the oil filler opening.
 - Wipe up any spills immediately.

2. Securely reinstall the oil fill cap/dipstick

NOTICE Overfilling with oil or operating with insufficient oil can cause damage to your engine. Do not mix different brands and grades of oil.

For the recommended oil and oil selection guidelines, see “Maintenance Fundamentals.” P. 58

Checking the Coolant

Check the coolant level in the reserve tank while the engine is cold.

1. Place your vehicle on its center stand on a firm, level surface.
2. Remove the battery lid. P. 65
3. Check that the coolant level is between the UPPER level and LOWER level marks on the reserve tank.

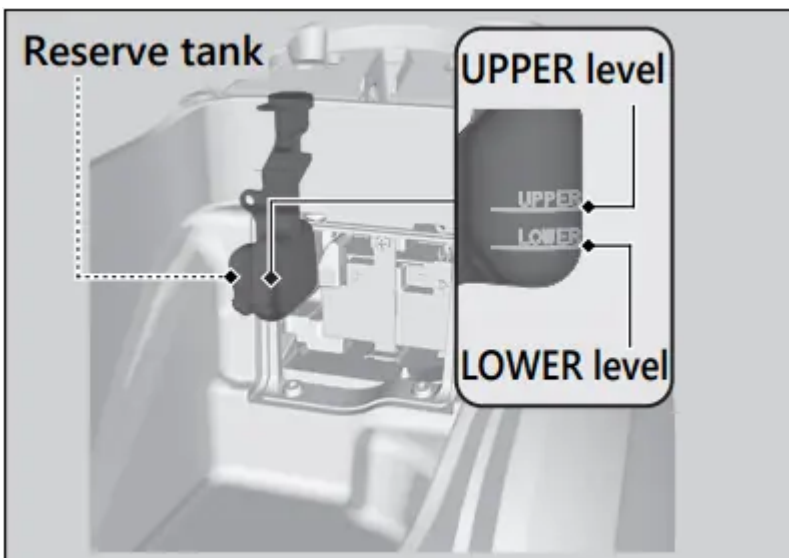

If the coolant level is dropping noticeably or the reserve tank is empty, you likely have a serious leak. Have your vehicle inspected by your dealer.

Adding Coolant

If the coolant level is below the LOWER level mark, add the recommended coolant (P. 59) until the level reaches the UPPER level mark.

Add fluid only from the reserve tank cap and do not remove the radiator cap.

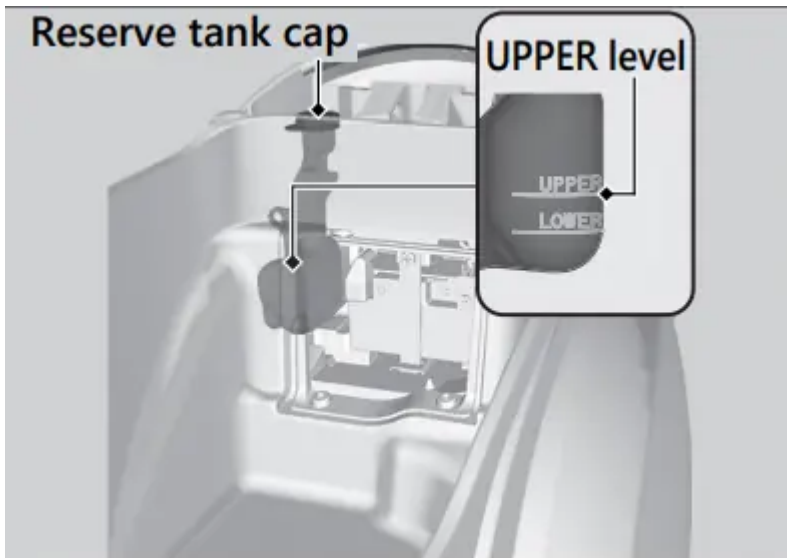

1. Remove the battery lid. P. 65
2. Remove the maintenance cover. P. 67
3. Remove the reserve tank cap and add fluid while monitoring the coolant level.
 - Do not overfill above the UPPER level mark.
 - Make sure no foreign objects enter the reserve tank opening.
4. Securely reinstall the reserve tank cap.
5. Install the maintenance cover. P. 67
6. Install the battery lid. P. 65

WARNING Removing the radiator cap while the engine is hot can cause the coolant to spray out, potentially scalding you. Always let the engine and radiator cool down before removing the radiator cap.

Brakes

Inspecting the Brake Lever Freeplay

1. Place your vehicle on its center stand on a firm, level surface.
2. Measure the distance the front and rear brake levers move before each brake takes hold.

Freeplay at the tip of the brake levers: 3/8 - 13/16 in (10 - 20 mm)

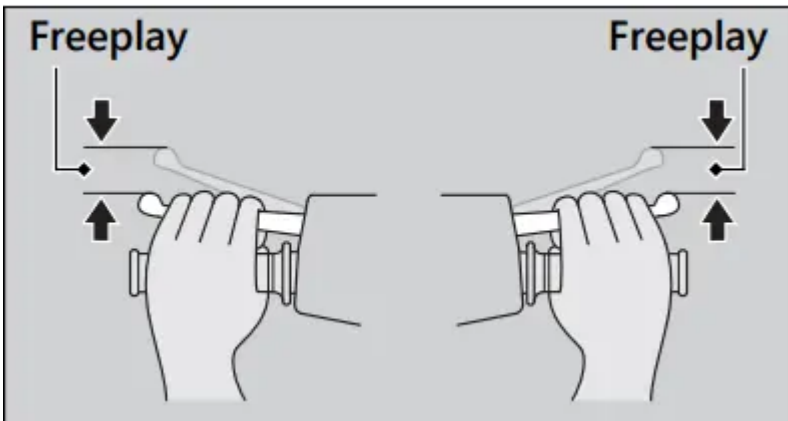

Adjusting the Rear Brake Lever Freeplay

Adjust the freeplay of the brake lever with the front wheel pointed straight ahead. Make sure the cut-out on the adjusting nut is seated on the brake arm pin when adjusting the freeplay.

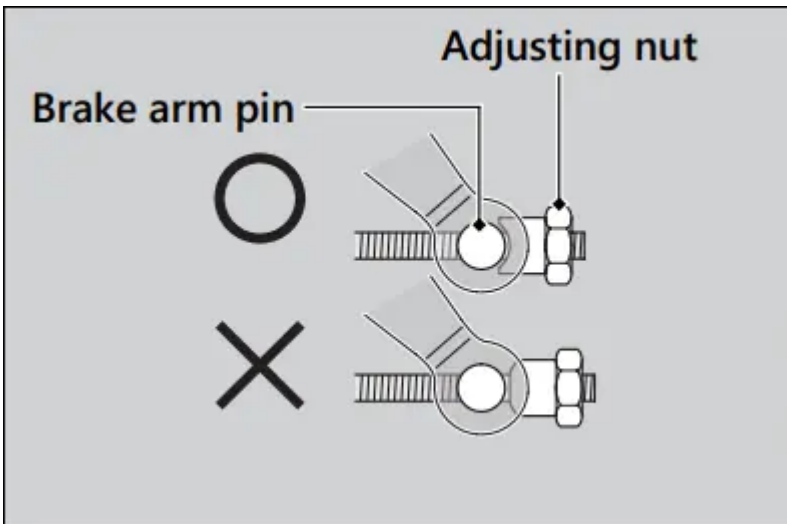

If proper adjustment cannot be obtained by this method, see your dealer.

1. Adjust by turning the rear brake adjusting nut a half-turn at a time.

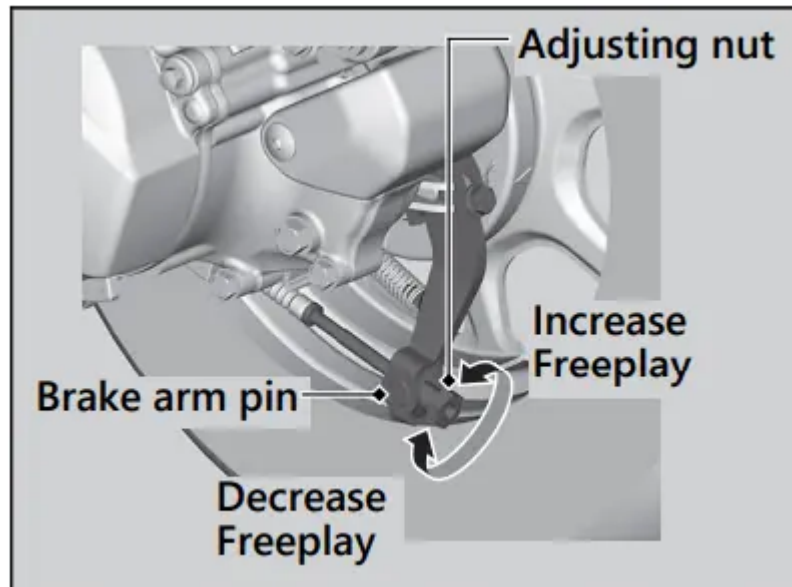

2. Apply the brake several times and check for free wheel rotation after the brake lever is released.
3. Push the brake arm to confirm that there is a gap between the rear brake adjusting nut and brake arm pin.

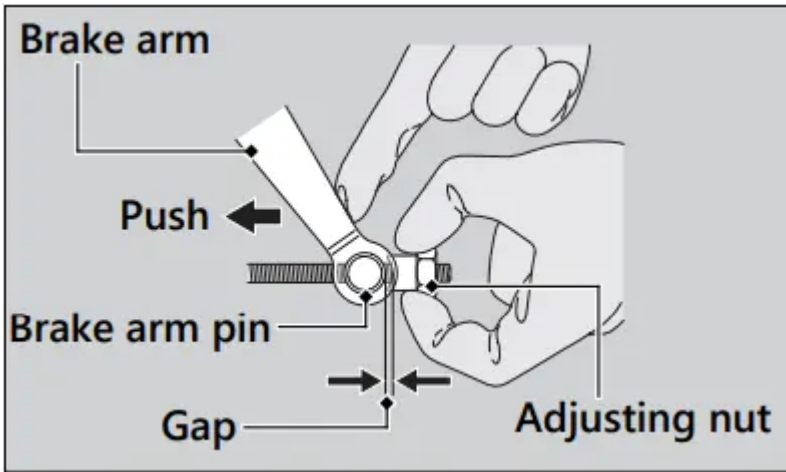

After adjustment, confirm the freeplay of the brake lever.

Make sure the brake arm, spring and fastener are in good condition.

NOTICE

Do not turn the adjuster beyond its natural limits.

Adjusting the Front Brake Lever Freeplay

Adjust the freeplay of the brake lever with the front wheel pointed straight ahead. Make sure the cut-out on the adjusting nut is seated on the brake arm pin when adjusting the freeplay.

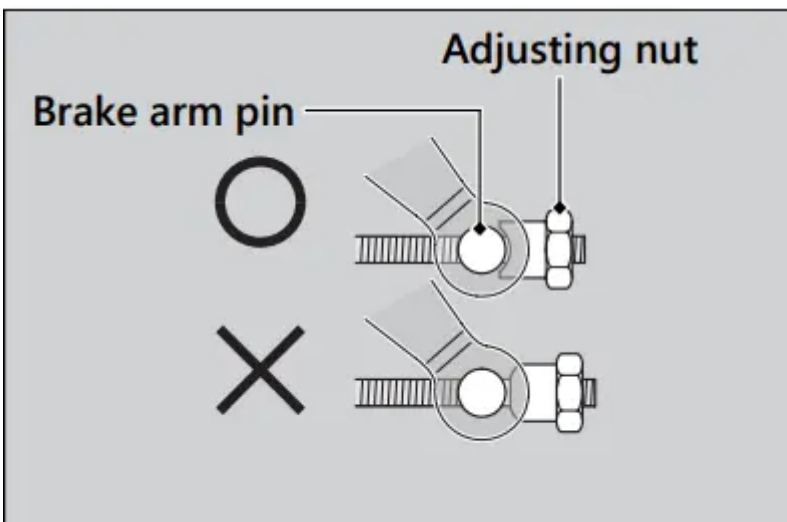

If proper adjustment cannot be obtained by this method, see your dealer.

1. Adjust by turning the front brake adjusting nut a half-turn at a time.

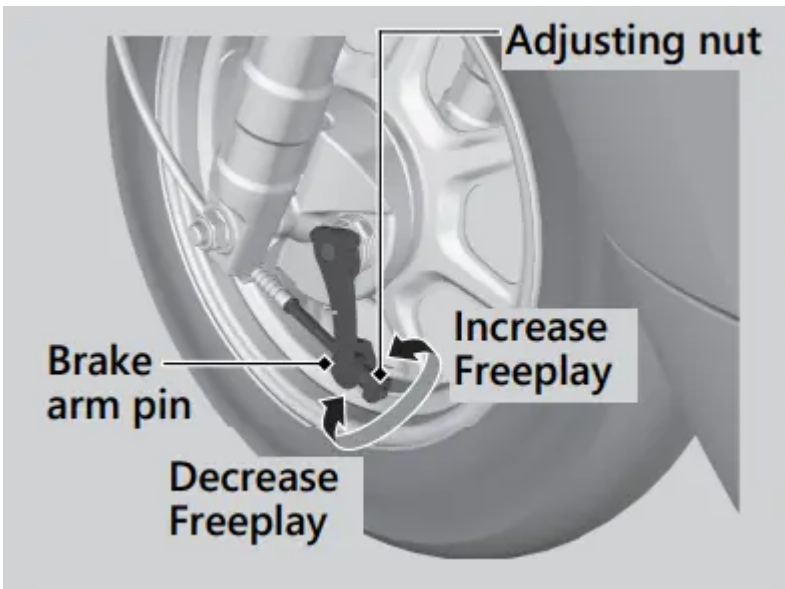

2. Apply the brake several times and check for free wheel rotation after the brake lever is released.
3. Push the brake arm to confirm that there is a gap between the front brake adjusting nut and brake arm pin.

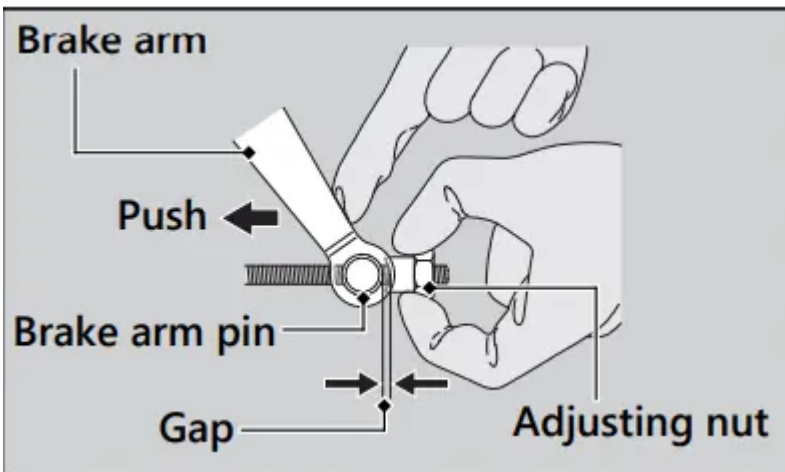

After adjustment, confirm the freeplay of the brake lever.

NOTICE Do not turn the adjuster beyond its natural limits.

Make sure the brake arm, spring and fastener are in good condition.

Inspecting the Brake Shoe Wear

The front and rear brake are equipped with a brake wear indicator.

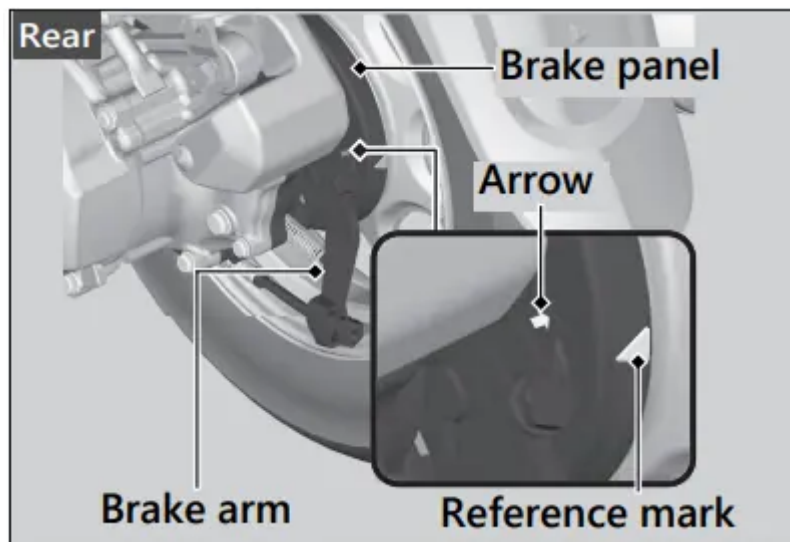
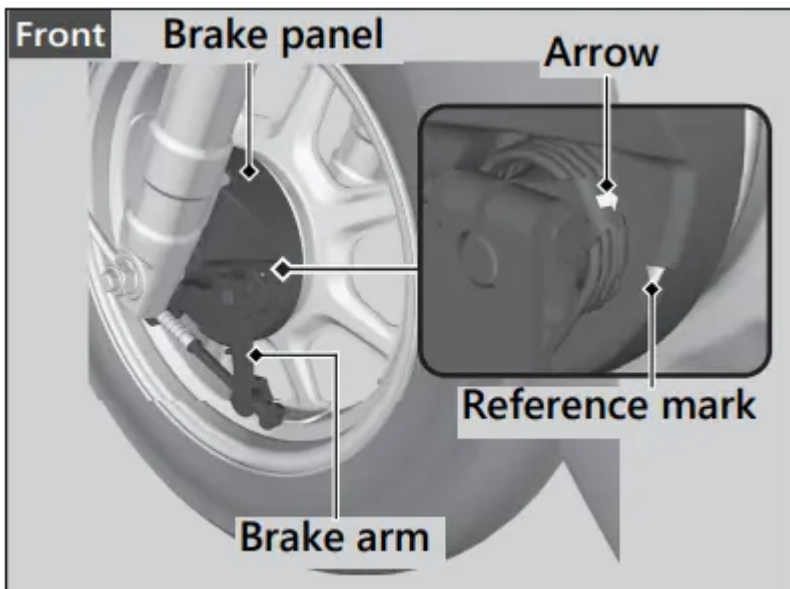

When the brake is applied, an arrow attached to the brake arm moves toward a reference mark on the brake panel. If the arrow aligns with the reference mark on full application of the brake, the brake shoes must be replaced. See your dealer for this service.

When the brake service is necessary, see your dealer. Use only Honda Genuine Parts or its equivalent.

Throttle

Checking the Throttle

With the engine off, check that the throttle rotates smoothly from fully closed to fully open in all steering positions and throttle freeplay is correct. If the throttle does not move smoothly, close automatically, or if the cable is damaged, have the vehicle inspected by your dealer.

Freeplay at the throttle grip flange: 1/16 - 1/4 in (2 - 6 mm)

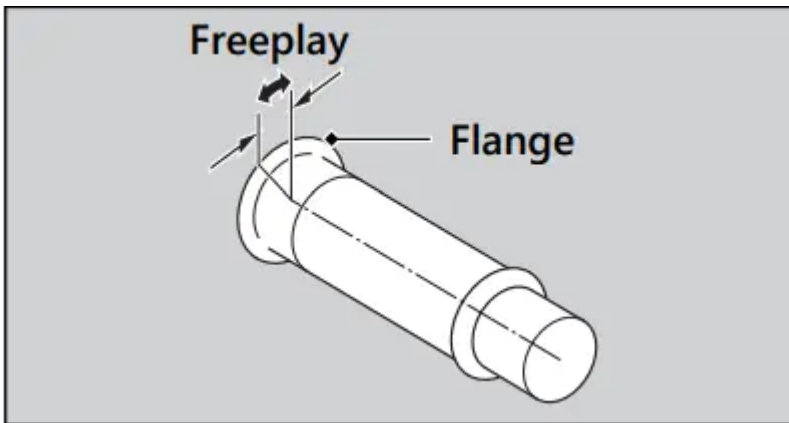

Adjusting the Throttle Freeplay

1. Loosen the lock nut.
2. Turn the adjuster until the freeplay is 1/16 - 1/4 in (2 - 6 mm).
3. Tighten the lock nut and inspect the throttle action again.

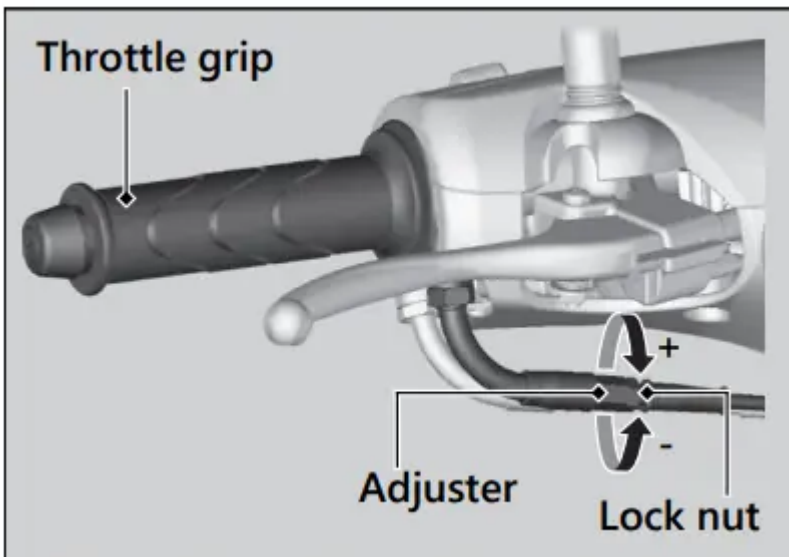

Troubleshooting

Engine Will Not Start

Starter Motor Operates But Engine Does Not Start

Check the following items:

- Check the correct engine starting sequence. 2 P. 31
- Check that there is gasoline in the fuel tank.
- Check if the PGM-FI malfunction indicator lamp (MIL) is on.
 - If the indicator lamp is on, contact your dealer as soon as possible.

Starter Motor Does Not Operate

Check the following items:

- Check the correct engine starting sequence. P. 31
- Make sure engine stop switch is in the  (Run) position. P. 26
- Check for a blown fuse. P. 89
- Check for a loose battery connection (P. 64) or battery terminal corrosion (2 P. 54).
- Check the condition of the battery.P. 84

If the problem continues, have your vehicle inspected by your dealer.

Overheating (High coolant temperature indicator is on)

The engine is overheating when the following occurs:

- High coolant temperature indicator comes on.
- Acceleration becomes sluggish. If this occurs, pull safely to the side of the road and perform the following procedure.

Extended fast idling may cause the high coolant temperature indicator to come on.

NOTICE Continuing to ride with an overheated engine can cause serious damage to the engine.

1. Stop the engine using the ignition switch.
2. Allow the engine to cool with the ignition switch in the OFF position.
3. After the engine has cooled, inspect the radiator hose and check if there is a leak.

If there is a leak: Do not start the engine. Transport your vehicle to your dealer.

4. Check the coolant level in the reserve tank. Add coolant as necessary.
5. If 1-4 check normal, you may continue riding, but closely monitor the high coolant temperature indicator.

Warning Indicators On or Flashing

PGM-FI (Programmed Fuel Injection) Malfunction Indicator Lamp (MIL)

If the indicator comes on while riding, you may have a serious problem with the PGM-FI system. Reduce speed and have your vehicle inspected by your dealer as soon as possible.

Other Warning Indications

Fuel Gauge Failure Indication

If the fuel system has an error, the fuel gauge indicators will be displayed as shown in the illustration.

If this occurs, see your dealer as soon as possible.

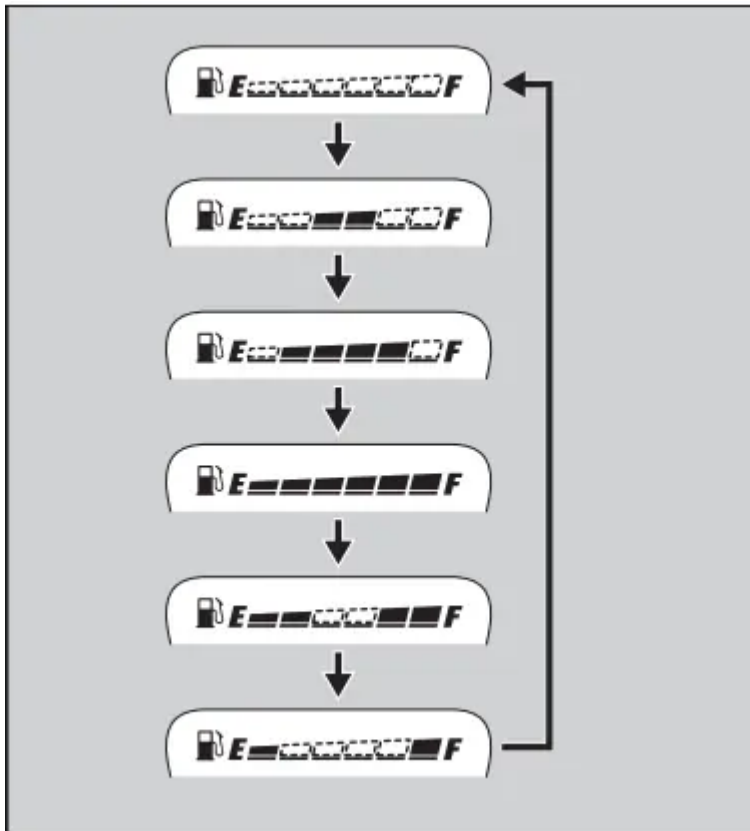

Tire Puncture

Repairing a puncture or removing a wheel requires special tools and technical expertise. We recommend you have this type of service performed by your dealer. After an emergency repair, always have the tire inspected/replaced by your dealer.

Emergency Repair Using a Tire Repair Kit

If your tire has a minor puncture, you can make an emergency repair using a tubeless tire repair kit. Follow the instructions provided with the emergency tire repair kit. Riding your vehicle with a temporary tire repair is very risky. Do not exceed 30 mph (50 km/h). Have the tire replaced by your dealer as soon as possible.

WARNING Riding your vehicle with a temporary tire repair can be risky. If the temporary repair fails, you can crash and be seriously injured or killed. If you must ride with a temporary tire repair, ride slowly and carefully and do not exceed 30 mph (50 km/h) until the tire is replaced.

Electrical Trouble

Battery Goes Dead

Charge the battery using a motorcycle battery charger. Remove the battery from the vehicle before charging.

Do not use an automobile-type battery charger, as these can overheat a motorcycle battery and cause permanent damage. If the battery does not recover after recharging, contact your dealer.

NOTICE Jump starting using an automobile battery can damage your vehicle's electrical system and is not recommended. Bump starting is also not recommended.

Burned-out Light Bulb

Follow the procedure below to replace a burned-out light bulb. Turn the ignition switch to the OFF or  (Lock) position.

Allow the bulb to cool before replacing it. Do not use bulbs other than those specified. Check the replacement bulb for correct operation before riding.

For the light bulb wattage, see “Specifications.”

Headlight Bulb

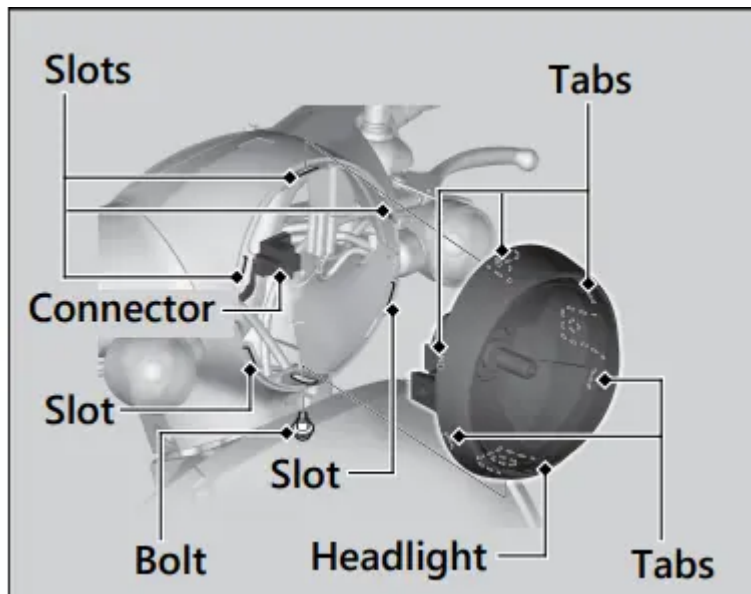

1. Remove the bolt from the headlight case.
2. Remove the tabs from the slots by gently pulling the lower end of the headlight forward and remove the headlight.
3. Disconnect the connector.

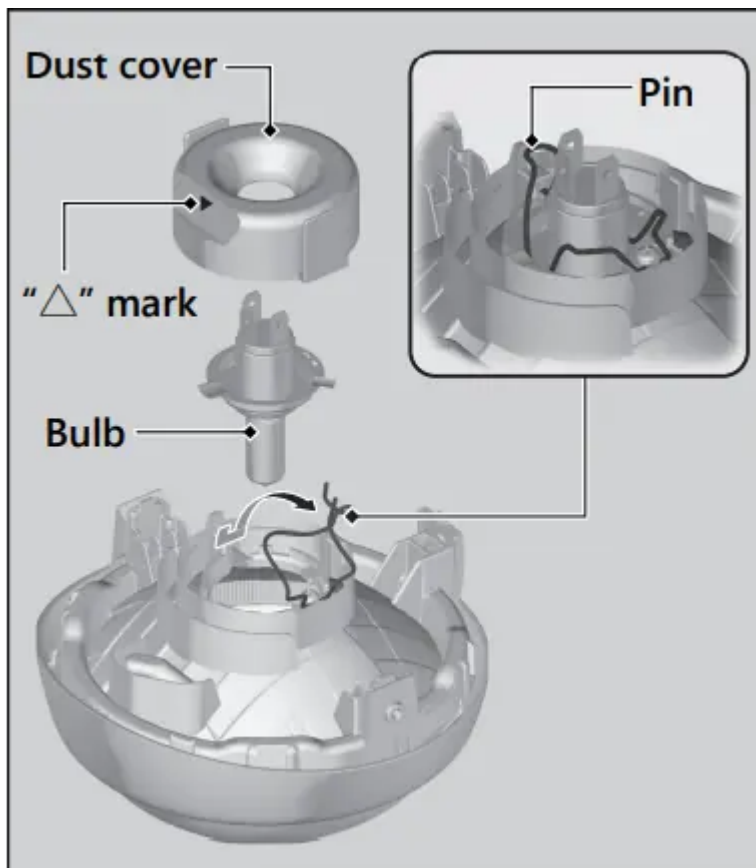

4. Remove the dust cover.
5. Unhook the pin and remove the bulb.
6. Install a new bulb and parts in the reverse order of removal.
 - Install the dust cover with its "5" mark facing up.

Do not touch the glass surface with your fingers. If you touch the bulb with your bare hands, clean it with a cloth moistened with isopropyl (rubbing) alcohol.

Brake light/Taillight Bulb

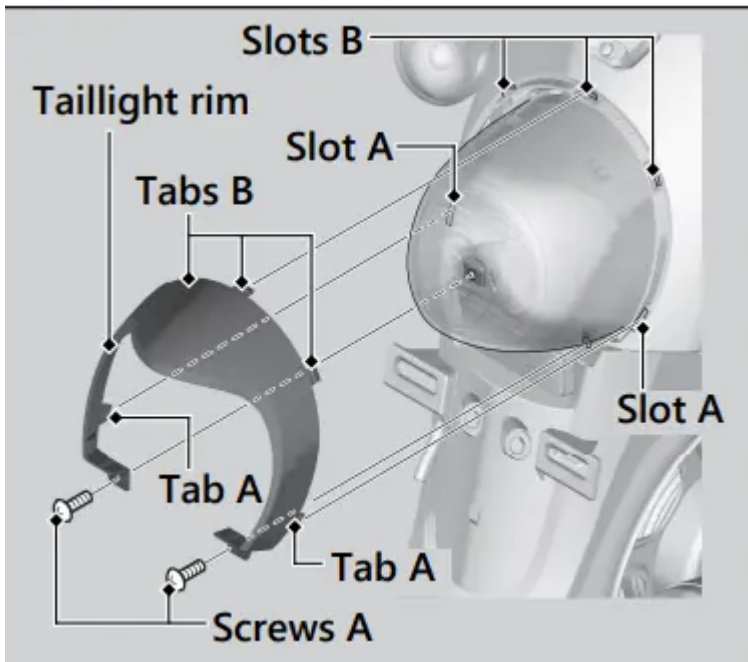

1. Remove the screws A.
2. Raise the lower side of taillight rim and remove the tabs A from the slots A.
3. Remove the taillight rim by pulling the taillight rim and removing the tabs B from the slots B.

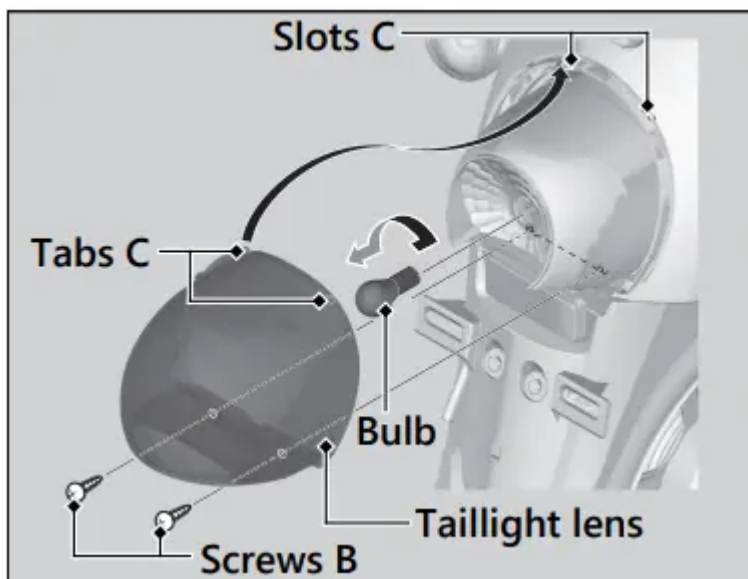

4. Remove the screws B.
5. Remove the tabs C from the slots C by lowering the taillight lens and remove the lens.
6. Slightly press the bulb in and turn it counterclockwise.
7. Install a new bulb and parts in the reverse order of removal.

Front/Rear Turn Signal Bulb

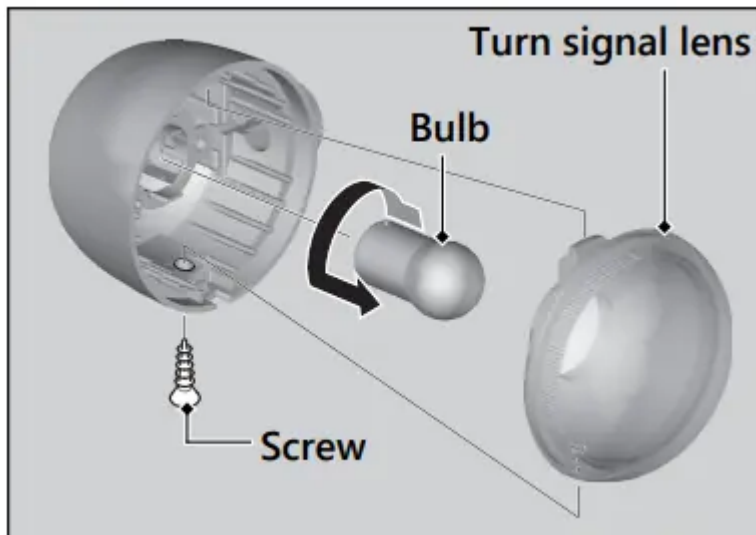

1. Remove the turn signal lens by removing the screw.
2. Slightly press the bulb and turn it counterclockwise.
3. Install a new bulb and parts in the reverse order of removal.
 - Use only the amber bulb.
 - After putting back the lens packing in place, install the turn signal lens.

Blown Fuse

Before handling fuses, see “Inspecting and Replacing Fuses.”

Fuse Box Fuses

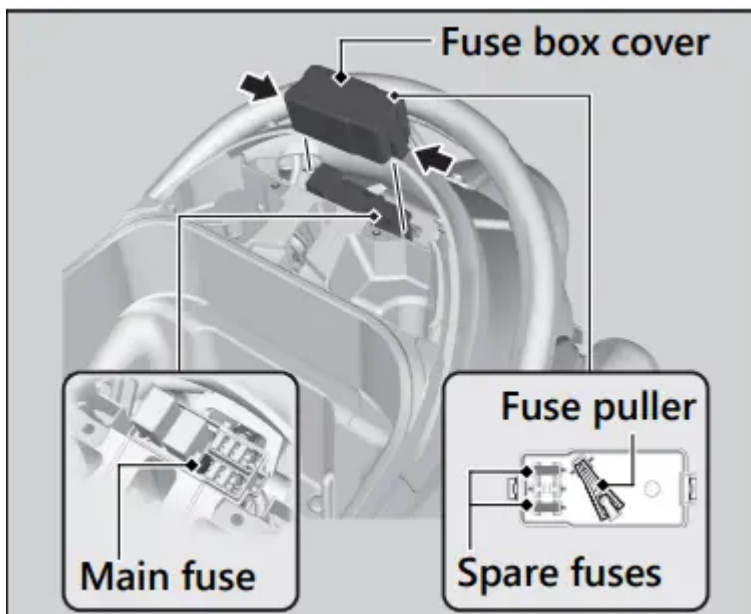

1. Remove the maintenance cover. 2 P. 67
2. Pull out the fuse box cover.

3. Pull the main fuse and other fuses out with the fuse puller furnished in reverse side of the fuse box cover one by one and check for a blown fuse. Always replace a blown fuse with a spare fuse of the same rating.

- Spare fuses are provided on reverse side of the fuse box cover.

4. Reinstall the fuse box cover.

5. Install the maintenance cover.

NOTICE If a fuse fails repeatedly, you likely have an electrical problem. Have your vehicle inspected by your dealer.

Unstable Engine Operation Occurs Intermittently

If the fuel pump filter is clogged, unstable engine operation will occur intermittently while riding. Even if this symptom occurs, you can continue to ride your vehicle.

If unstable engine operation occurs even if sufficient fuel is available, have your vehicle inspected by your dealer as soon as possible.

Instruments, Controls, & Other Features

Ignition Switch

Leaving the ignition switch in the ON position with the engine stopped will drain the battery.

Do not turn the key while riding.

Engine Stop Switch

Do not use the engine stop switch except in an emergency. Doing so when riding will cause the engine to suddenly turn off, making riding unsafe.

If you stop the engine using the engine stop switch, turn the ignition switch to the OFF position. Failing to do so will drain the battery.

Odometer

The display locks at 999,999 when the read-out exceeds 999,999.

Tripmeter

The tripmeter returns to 0.0 when the read-out exceeds 999.9.

Document Bag

The owner's manual, registration, and insurance information can be stored in the plastic document bag located in the center compartment.

Caring for Your Vehicle

Frequent cleaning and polishing is important to ensure the life of your Honda. A clean vehicle makes it easier to spot potential problems. In particular, seawater and salts used to prevent ice on roads promote the formation of corrosion. Always wash your vehicle thoroughly after riding on coastal or treated roads.

Washing

Allow the engine, muffler, brakes, and other high-temperature parts to cool before washing.

1. Rinse your vehicle thoroughly using a low pressure garden hose to remove loose dirt.
2. If necessary, use a sponge or a soft towel with mild cleaner to remove road grime.
 - Clean the headlight lens, panels, and other plastic components with extra care to avoid scratching them. Avoid directing water into the air cleaner, muffler, and electrical parts.
3. Thoroughly rinse your vehicle with plenty of clean water and dry with a soft, clean cloth.
4. After the vehicle dries, lubricate any moving parts.
 - Make sure that no lubricant spills onto the brakes or tires. Brake discs, pads, drum or shoes contaminated with oil will suffer greatly reduced braking effectiveness and can lead to a crash.
5. Apply a coat of wax to prevent corrosion.
 - Avoid products that contain harsh detergents or chemical solvents. These can damage the metal, paint, and plastic on your vehicle. Keep the wax clear of the tires and brakes.
 - If your vehicle has any matte painted parts, do not apply a coat of wax to the matte painted surface.

Washing Precautions

Follow these guidelines when washing:

- Do not use high-pressure washers:
 - High-pressure water cleaners can damage moving parts and electrical parts, rendering them inoperable.
 - Water in the air intake can be drawn into the throttle body and/or enter the air cleaner.
- Do not direct water at the muffler:
 - Water in the muffler can prevent starting and causes rust in the muffler.

- Dry the brakes:
 - Water adversely affects braking effectiveness. After washing, apply the brakes intermittently at low speed to help dry them.
- Do not direct water under the seat:
 - Water in the under seat compartment can damage your documents and other belongings.
- Do not direct water at the air cleaner:
 - Water in the air cleaner can prevent the engine from starting.
- Do not direct water near the headlight:
 - The headlight's inside lens may fog temporarily after washing or while riding in the rain. This does not impact the headlight function.
 - Any condensation inside the headlight should dissipate after a few minutes of running the engine with the headlight(s) on. However, if you see a large amount of water or ice accumulated inside the lens(es), have your vehicle inspected by your dealer.
- Do not use wax or polishing compounds on matte painted surface:
 - Use a soft cloth or sponge, plenty of water, and a mild detergent to clean matte painted surfaces. Dry with a soft clean cloth.

Aluminum Components

Aluminum will corrode from contact with dirt, mud, or road salt. Clean aluminum parts regularly and follow these guidelines to avoid scratches:

- Do not use stiff brushes, steel wool, or cleaners containing abrasives.
- Avoid riding over or scraping against curbs.

Panels

Follow these guidelines to prevent scratches and blemishes:

- Wash gently using a soft sponge and plenty of water.
- To remove stubborn stains, use diluted detergent and rinse thoroughly with plenty of water.
- Avoid getting gasoline or detergents on the instruments, panels, or headlight.

Exhaust Pipe and Muffler

When the exhaust pipe and muffler are painted, do not use a commercially available abrasive kitchen cleaning compound. Use a neutral detergent to clean the painted surface on the exhaust pipe and muffler. If you are not sure if your exhaust pipe and muffler are painted, contact your dealer.

Vehicle Identification Number

The VIN and engine serial number uniquely identify your vehicle and are required in order to register your vehicle. They may also be required when ordering replacement parts.

You should record these numbers and keep them in a safe place.

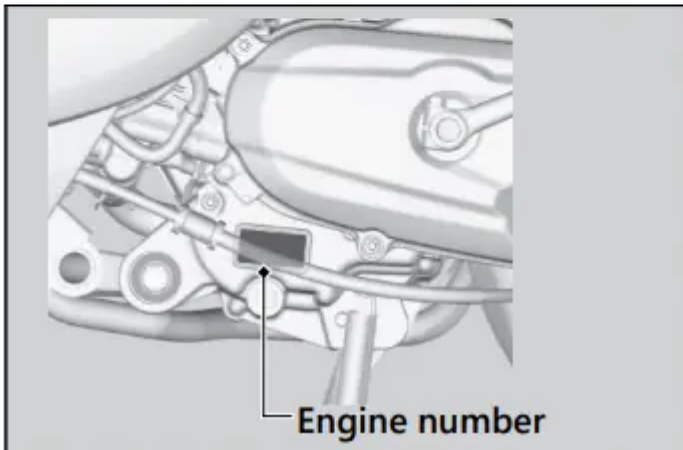
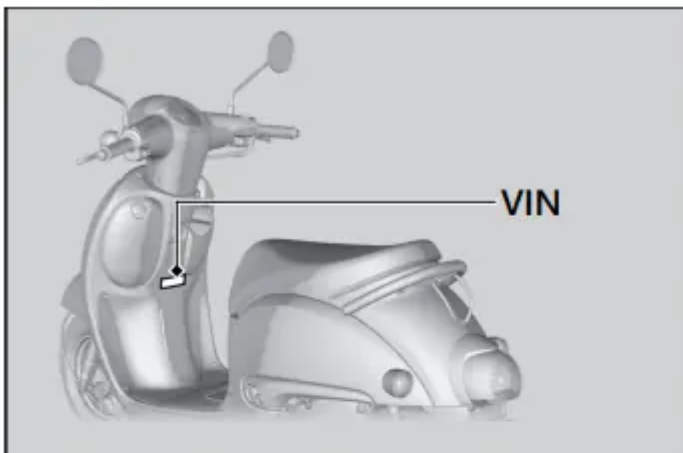
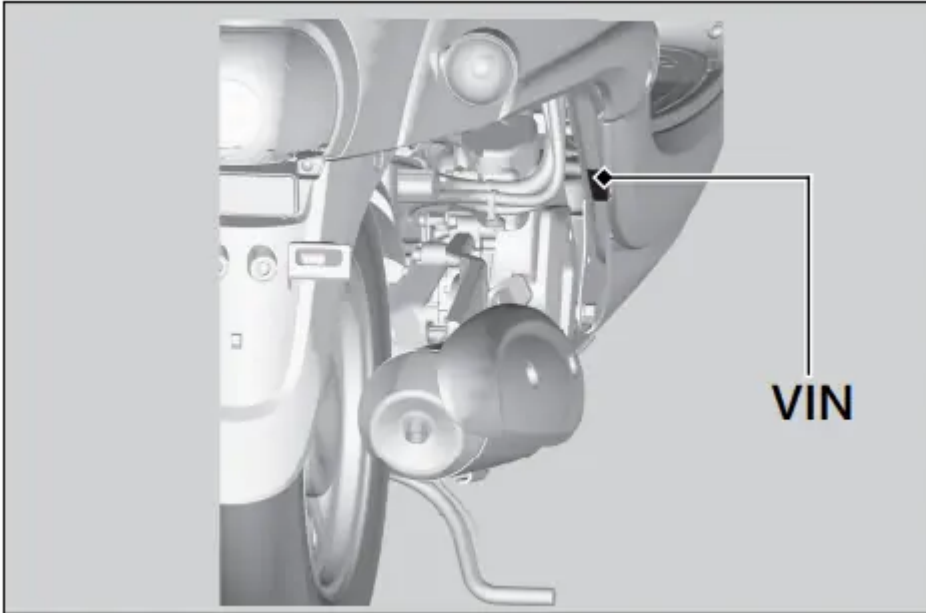

Warning

This content is compiled from multiple sources and is provided for reference purposes only. It may not be complete or fully applicable to all situations. If you are unable to resolve your issue, please contact the product manufacturer or an authorized service provider for official support.

Document generated by [ManualsFile](#)