

## PARTS REFERENCE

### For Pools with Dual Suction Outlets Configuration:

In order to comply with the requirement of the Virginia Grahame Baker Act (for USA and Canada), your pool is designed with dual suction outlets and one inlet fittings. Overview of the dual suction outlets configuration is as follow:

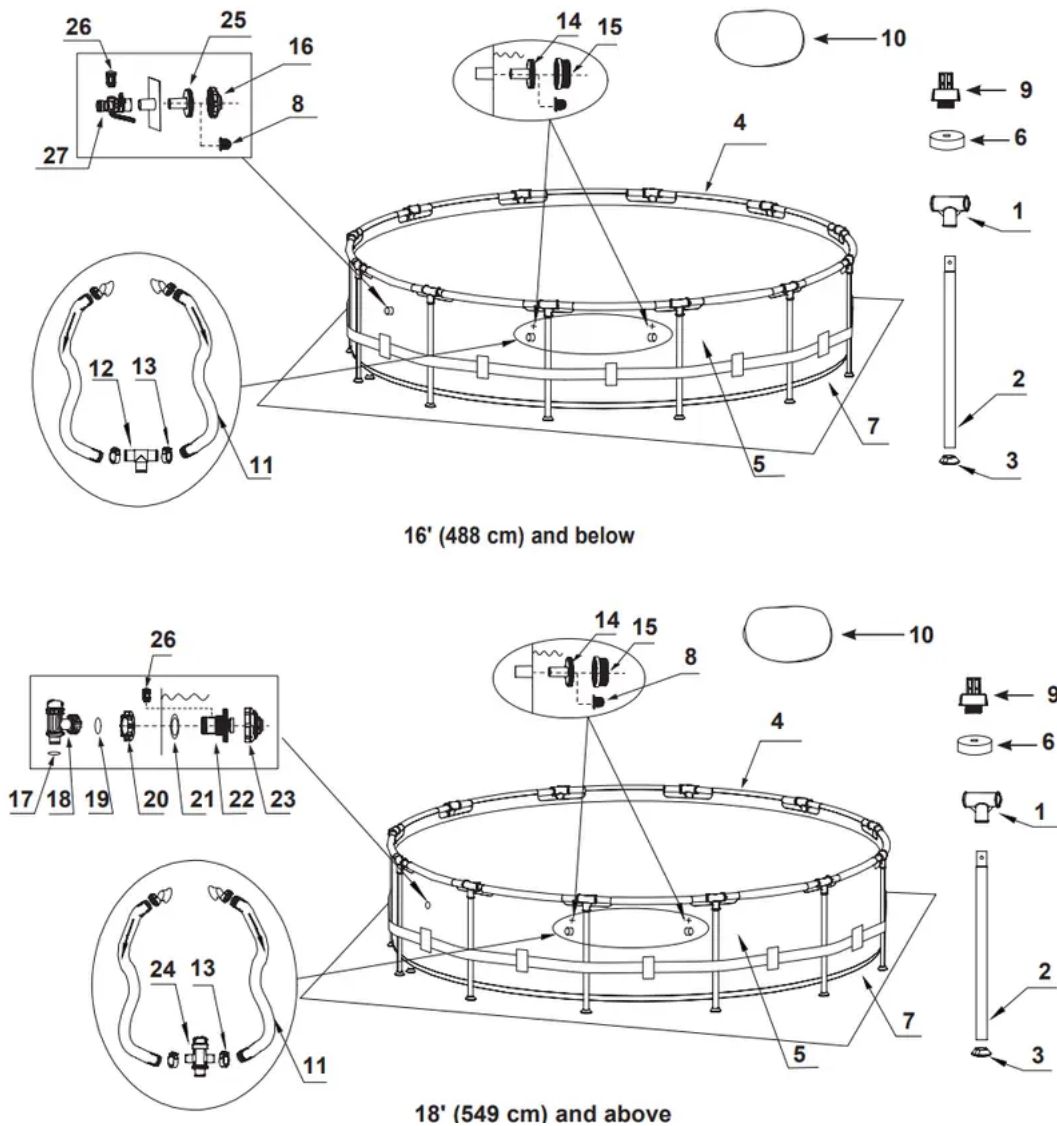

**NOTE:** Drawings for illustration purpose only. Actual product may vary. Not to scale.

FOR PRISM FRAME™ PREMIUM POOL

REF NO.	DESCRIPTION	POOL SIZE & QUANTITIES								
		10' (305cm)	12' (366cm)	13' (396cm)	14' (427cm)	15' (457cm)	16' (488cm)	18' (549cm)	20' (610cm)	24' (732cm)
1	T - JOINT	10	12	13	14	15	16	18	20	24
2	VERTICAL LEG	10	12	13	14	15	16	18	20	24
3	LEG CAP	10	12	13	14	15	16	18	20	24
4	HORIZONTAL BEAM	10	12	13	14	15	16	18	20	24
5	POOL LINER (DRAIN VALVE CAP INCLUDED)	1	1	1	1	1	1	1	1	1
6	DRAIN VALVE CAP	1	1	1	1	1	1	2	2	2
7	GROUND CLOTH	-	-	-	1	1	1	1	1	1
8	STRAINER HOLE PLUG	3	3	3	3	3	3	2	2	2
9	DRAIN CONNECTOR	1	1	1	1	1	1	1	1	1
10	POOL COVER	-	-	1	1	1	1	1	1	1
11	HOSE	2	2	2	2	2	2	2	2	2
12	HOSE T-JOINT	1	1	1	1	1	1	-	-	-
13	HOSE CLAMP	8	8	8	8	8	8	4	4	4
14	STRAINER CONNECTOR	2	2	2	2	2	2	2	2	2
15	STRAINER GRID	2	2	2	2	2	2	2	2	2
16	POOL INLET JET NOZZLE	1	1	1	1	1	1	-	-	-
17	HOSE O-RING	-	-	-	-	-	-	1	1	1
18	PLUNGER VALVE (HOSE O-RING & STEP WASHER INCLUDED)	-	-	-	-	-	-	1	1	1
19	STEP WASHER	-	-	-	-	-	-	1	1	1
20	STRAINER NUT	-	-	-	-	-	-	1	1	1
21	FLAT STRAINER RUBBER WASHER	-	-	-	-	-	-	1	1	1
22	INLET THREADED AIR CONNECTOR +	-	-	-	-	-	-	1	1	1
23	ADJUSTABLE POOL INLET JET NOZZLE	-	-	-	-	-	-	1	1	1
24	SPLIT HOSE PLUNGER VALVE	-	-	-	-	-	-	1	1	1
25	INLET STRAINER CONNECTOR	1	1	1	1	1	1	-	-	-
26	AIR JET VALVE	1	1	1	1	1	1	1	1	1
27	POOL INLET AIR ADAPTOR +	1	1	1	1	1	1	-	-	-
28	AIR JET VALVE CAP (NOT SHOWN)	1	1	1	1	1	1	1	1	1

REF NO.	DESCRIPTION	10' X 30'	12' X 30'	12' X 32'	12' X 36'	13' X 36'	14' X 42'	15' X 32'	15' X 36'	15' X 42'	15' X 48'	15' X 48'	20' X 52'	24' X 52'
		(305cm X 76cm)	(366cm X 76cm)	(366cm X 84cm)	(366cm X 91cm)	(396cm X 91cm)	(427cm X 107cm)	(457cm X 84cm)	(457cm X 91cm)	(457cm X 107cm)	(457cm X 122cm)	(488cm X 122cm)	(549cm X 122cm)	(610cm X 132cm)
SPARE PART NO.														
1	T - JOINT	12801	12801	12801	12801	12802	12802	12802	12802	12802	12802	12802	12803	12803
2	VERTICAL LEG	12823	12823	12825	12824	12576	12828	12574	12575	12828	12829	12829	12830	12831
3	LEG CAP	12454	12454	12454	12454	12465	12465	12465	12465	12465	12465	12465	12476	12476
4	HORIZONTAL BEAM	12807	12807	12807	12807	12809	12809	12809	12809	12809	12809	12809	12822	12822
5	POOL LINER (DRAIN VALVE CAP INCLUDED)	10084E	10085E	12878E	10086E	12880E	10088E	12881E	12882E	10089E	10090E	10091E	10092E	10093E
6	DRAIN VALVE CAP	10649	10649	10649	10649	10649	10649	10649	11044	11044	11044	11044	11044	11044
7	GROUND CLOTH	-	-	-	-	-	10080	18932	18932	18932	18932	18932	11290	18935
8	STRAINER HOLE PLUG	10127	10127	10127	10127	10127	10127	10127	10127	10127	10127	10127	10127	10127
9	DRAIN CONNECTOR	10184	10184	10184	10184	10184	10184	10184	10184	10184	10184	10184	10184	10184
10	POOL COVER	-	-	-	-	11142	11054	18901	18901	18901	18901	10754	18937	11289
11	HOSE	11873	11873	11873	11873	11873	11873	11873	11873	11873	11873	11873	11873	11873
12	HOSE T-JOINT	11871	11871	11871	11871	11871	11871	11871	11871	11871	11871	11871	-	-
13	HOSE CLAMP	11489	11489	11489	11489	11489	11489	11489	11489	11489	11489	11489	10122	10122
14	STRAINER CONNECTOR	11070	11070	11070	11070	11070	11070	11070	11070	11070	11070	11070	11070	11070
15	STRAINER GRID	11072	11072	11072	11072	11072	11072	11072	11072	11072	11072	11072	11072	11072
16	POOL INLET JET NOZZLE	12364	12364	12364	12364	12364	12364	12364	12364	12364	12364	12364	-	-
17	HOSE O-RING	-	-	-	-	-	-	-	-	-	-	-	10262	10262
18	PLUNGER VALVE (HOSE O-RING & STEP WASHER INCLUDED)	-	-	-	-	-	-	-	-	-	-	-	10747	10747
19	STEP WASHER	-	-	-	-	-	-	-	-	-	-	-	10745	10745
20	STRAINER NUT	-	-	-	-	-	-	-	-	-	-	-	10256	10256
21	FLAT STRAINER RUBBER WASHER	-	-	-	-	-	-	-	-	-	-	-	10255	10255
22	INLET THREADED AIR CONNECTOR +	-	-	-	-	-	-	-	-	-	-	-	12371	12371
23	ADJUSTABLE POOL INLET JET NOZZLE	-	-	-	-	-	-	-	-	-	-	-	12372	12372
24	SPLIT HOSE PLUNGER VALVE	-	-	-	-	-	-	-	-	-	-	-	12369	12369
25	1-1/4" INLET STRAINER CONNECTOR	12365	12365	12365	12365	12365	12365	12365	12365	12365	12365	12365	-	-
26	AIR JET VALVE	12363	12363	12363	12363	12363	12363	12363	12363	12363	12363	12363	12363	12363
27	POOL INLET AIR ADAPTOR +	12366	12366	12366	12366	12366	12366	12366	12366	12366	12366	12366	12366	12366
28	AIR JET VALVE CAP (NOT SHOWN)	12373	12373	12373	12373	12373	12373	12373	12373	12373	12373	12373	12373	12373

- If applicable, depending on the size of the filter pump fitted with your pool, you must quote the model number shown on the filter pump housing to order the correct size of “Pool Inlet Air Adaptor ” or “Inlet Threaded Air Connector” replacement part.

**FOR GREYWOOD PRISM FRAME™ PREMIUM POOL**



REF NO.	DESCRIPTION	15' X 48" (457CM X 122CM)		18' X 48" (549CM X 122CM)	
		QUANTITIES	SPARE PART NO.	QUANTITIES	SPARE PART NO.
1	T - JOINT	15	12802G	18	12803G
2	VERTICAL LEG	15	12829G	18	12830G
3	LEG CAP	15	12465	18	12476
4	HORIZONTAL BEAM	15	12821G	18	12822G
5	POOL LINER (DRAIN VALVE CAP INCLUDED)	1	10090EH	1	10092EH
6	DRAIN VALVE CAP	1	11044	2	11044
7	GROUND CLOTH	1	18932	1	18933
8	STRAINER HOLE PLUG	3	10127	2	10127
9	DRAIN CONNECTOR	1	10184	1	10184
10	POOL COVER	1	18901	1	18937
11	HOSE	2	11873	2	11873
12	HOSE T-JOINT	1	11871	-	-
13	HOSE CLAMP	8	11489	4	10122
14	STRAINER CONNECTOR	2	11070	2	11070
15	STRAINER GRID	2	11072	2	11072
16	POOL INLET JET NOZZLE	1	12364	-	-
17	HOSE O-RING	-	-	1	10262
18	PLUNGER VALVE (HOSE O-RING & STEP WASHER INCLUDED)	-	-	1	10747
19	STEP WASHER	-	-	1	10745
20	STRAINER NUT	-	-	1	10256
21	FLAT STRAINER RUBBER WASHER	-	-	1	10255
22	INLET THREADED AIR CONNECTOR +	-	-	1	12371 12372
23	ADJUSTABLE POOL INLET JET NOZZLE	-	-	1	12369
24	SPLIT HOSE PLUNGER VALVE	-	-	1	11872
25	1-1/4" INLET STRAINER CONNECTOR	1	12365	-	-
26	AIR JET VALVE	1	12363	1	12363
27	POOL INLET AIR ADAPTOR +	1	12366 12367 12368	-	-
28	AIR JET VALVE CAP (NOT SHOWN)	1	12373	1	12373

- If applicable, depending on the size of the filter pump fitted with your pool, you must quote the model number shown on the filter pump housing to order the correct size of “Pool Inlet Air Adaptor” or “Inlet Threaded Air Connector” replacement part.

Before assembling your product, please take a few minutes to check the contents and become familiar with all the parts.

**Non-USA & Canada:**

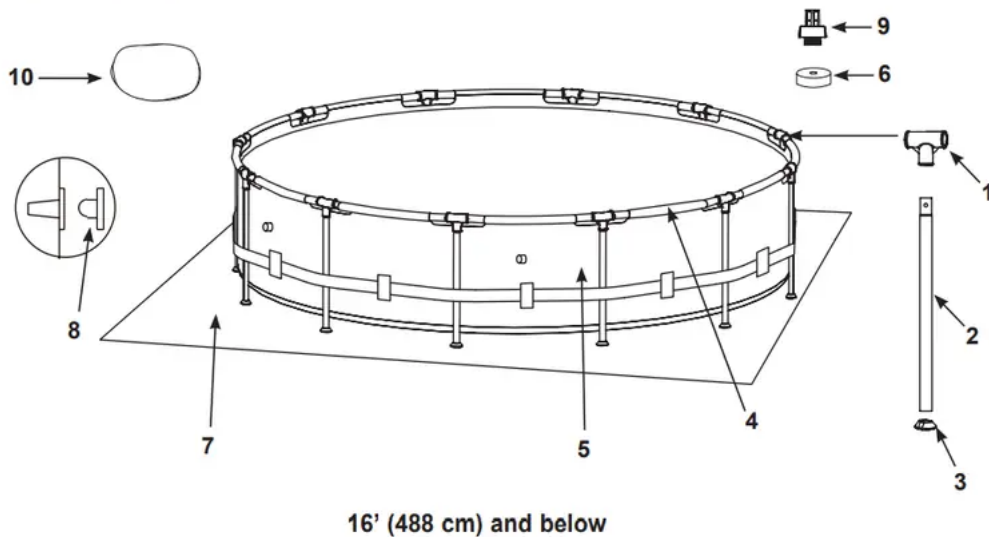

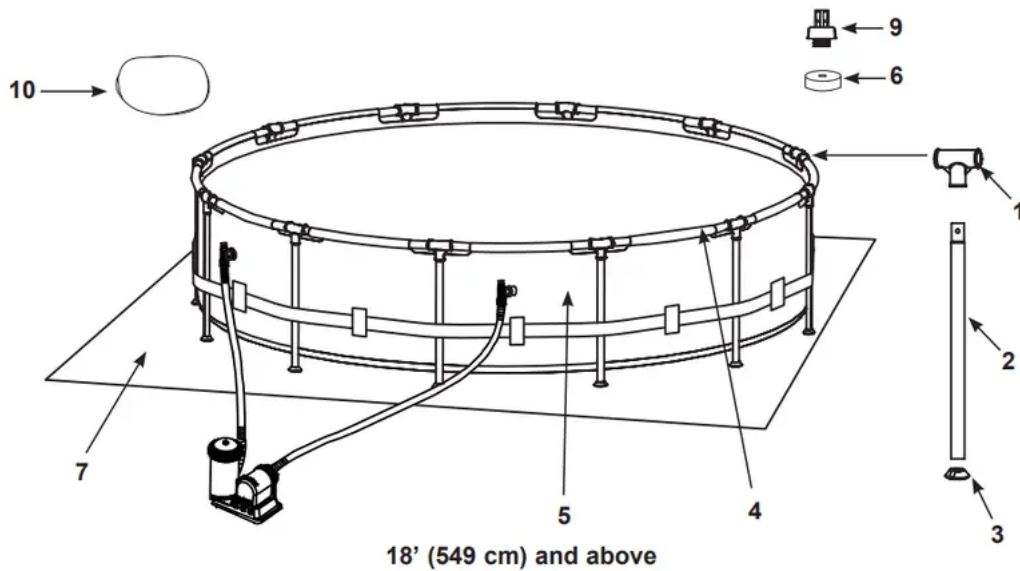

**NOTE: Drawings for illustration purpose only. Actual product may vary. Not to scale.**

**FOR PRISM FRAME™ PREMIUM POOL**

REF NO.	DESCRIPTION	POOL SIZE & QUANTITIES									
		10' (305cm)	12' (366cm)	13' (396cm)	14' (427cm)	15' (457cm)	16' (488cm)	18' (549cm)	20' (610cm)	24' (732cm)	
1	T - JOINT	10	12	13	14	15	16	18	20	24	
2	VERTICAL LEG	10	12	13	14	15	16	18	20	24	
3	LEG CAP	10	12	13	14	15	16	18	20	24	
4	HORIZONTAL BEAM	10	12	13	14	15	16	18	20	24	
5	POOL LINER (DRAIN VALVE CAP INCLUDED)	1	1	1	1	1	1	1	1	1	
6	DRAIN VALVE CAP	1	1	1	1	1	1	2	2	2	
7	GROUND CLOTH	-	-	-	1	1	1	1	1	1	
8	STRAINER HOLE PLUG (WITH 1 EXTRA)	3	3	3	3	3	3	-	-	-	
9	DRAIN CONNECTOR	1	1	1	1	1	1	1	1	1	
10	POOL COVER	-	-	1	1	1	1	1	1	1	

REF NO.	DESCRIPTION	10' X 30'	10' X 39'	12' X 30'	12' X 33'	12' X 36'	12' X 39'	12' X 48'	13' X 39'	14' X 42'
		(305cm X 76cm)	(305cm X 99cm)	(366cm X 76cm)	(366cm X 84cm)	(366cm X 91cm)	(366cm X 99cm)	(366cm X 122cm)	(396cm X 99cm)	(427cm X 107cm)
SPARE PART NO.										
1	T - JOINT	12801	12801	12801	12801	12801	12801	12801	12802	12802
2	VERTICAL LEG	12823	12824	12823	12825	12826	12824	12827	12576	12828
3	LEG CAP	12454	12454	12454	12454	12454	12454	12454	12465	12465
4	HORIZONTAL BEAM	12807	12807	12807	12807	12807	12807	12807	12809	12809
5	POOL LINER (DRAIN VALVE CAP INCLUDED)	10084	12877	10085	12878	12879	10086	10087	12880	10088
6	DRAIN VALVE CAP	10649	10649	10649	10649	10649	10649	10649	10649	10649
7	GROUND CLOTH	-	-	-	-	-	-	-	-	10080
8	STRAINER HOLE PLUG (WITH 1 EXTRA)	10127	10127	10127	10127	10127	10127	10127	10127	10127
9	DRAIN CONNECTOR	10184	10184	10184	10184	10184	10184	10184	10184	10184
10	POOL COVER	-	-	-	-	-	-	-	11142	11054



REF NO.	DESCRIPTION	15' X 33"	15' X 36"	15' X 42"	15' X 48"	16' X 48"	18' X 48"	20' X 52"	24' X 52"
		(457cm X 84cm)	(457cm X 91cm)	(457cm X 107cm)	(457cm X 122cm)	(488cm X 122cm)	(549cm X 122cm)	(610cm X 132cm)	(732cm X 132cm)
		SPARE PART NO.							
1	T - JOINT	12802	12802	12802	12802	12802	12803	12803	12803
2	VERTICAL LEG	12574	12575	12828	12829	12829	12830	12831	12831
3	LEG CAP	12465	12465	12465	12465	12465	12476	12476	12476
4	HORIZONTAL BEAM	12809	12809	12809	12809	12809	12822	12822	12822
5	POOL LINER (DRAIN VALVE CAP INCLUDED)	12881	12882	10089	10090	10091	10092	10093	10094
6	DRAIN VALVE CAP	10649	10649	11044	11044	11044	11044	11044	11044
7	GROUND CLOTH	18932	18932	18932	18932	18927	18933	11290	18935
8	STRAINER HOLE PLUG (WITH 1 EXTRA)	10127	10127	10127	10127	10127	-	-	-
9	DRAIN CONNECTOR	10184	10184	10184	10184	10184	10184	10184	10184
10	POOL COVER	18901	18901	18901	18901	10754	18937	11289	18929

## FOR GREYWOOD PRISM FRAME™ PREMIUM POOL

REF NO.	DESCRIPTION	15' X 48"		18' X 48"	
		(457CM X 122CM)		(549CM X 122CM)	
		QUANTITIES	SPARE PART NO.	QUANTITIES	SPARE PART NO.
1	T - JOINT	15	12802G	18	12803G
2	VERTICAL LEG	15	12829G	18	12830G
3	LEG CAP	15	12465	18	12476
4	HORIZONTAL BEAM	15	12809G	18	12822G
5	POOL LINER (DRAIN VALVE CAP INCLUDED)	1	10090G	1	10092G
6	DRAIN VALVE CAP	1	11044	2	11044
7	GROUND CLOTH	1	18932	1	18933
8	STRAINER HOLE PLUG (WITH 1 EXTRA)	3	10127	-	-
9	DRAIN CONNECTOR	1	10184	1	10184
10	POOL COVER	1	18901	1	18937

## POOL SETUP

Select an outdoor location for the pool with the following requirements in mind:

1. The area where the pool is to be set up must be absolutely flat and level. Do not set up the pool on a slope or inclined surface.
2. The ground surface must be compacted and firm enough to withstand the pressure and weight of a fully set up pool. Do not set up the pool on mud, sand, soft or loose soil conditions.
3. Do not set up the pool on a deck, balcony or platform, which may collapse under the weight of the filled pool.
4. The pool requires at least 4 feet of space all around pool from objects that a child could climb on to gain access to the pool.
5. Grass under the pool will be damaged. Splash out chlorinated pool water could damage the surrounding vegetation.

6. Above ground storable pools shall be located at a minimum distance of 6 ft (1.83 meters) from any receptacle, and all 125-volt 15- and 20-ampere receptacles located within 20 ft (6.0 meters) of the pool shall be protected by a ground fault circuit interrupter (GFCI), where distances are by measuring the shortest path the supply cord of an appliance connected to the receptacle would follow without piercing a floor, wall, ceiling, doorway with hinged or sliding door, window opening, or other effective permanent barrier.
7. Eliminate all aggressive grasses first. Certain types of grass such as St. Augustine and Bermuda, may grow through the liner. Grass growing through the liner it is not a manufacture defect and is not covered under warranty.
8. The area shall facilitate drainage of the pool water after each use and/or for long term pool storage

**IMPORTANT:** Before allowing anyone to use the pool, hold a family meeting. Establish a set of rules that include, at a minimum, the important safety rules and general aquatic safety information in this manual. Review these rules on a regular basis and with all users of the pool, including guests. The installer of the vinyl liner shall affix on the original or replacement liner, or on the pool structure, all safety signs in accordance with the manufacturer's instructions. The safety signs shall be placed above the water line.

You may have purchased this pool with the Intex Krystal Clear™ filter pump. The pump has its own separate set of installation instructions. First assemble your pool unit and then set up the filter pump.

Estimated assembly time 30-60 minutes. (Note the assembly time is only approximate and individual assembly experience may vary.)

## **1.Liner preparation**

- Find a flat, level location that is free and clear of stones, branches or other sharp objects that may puncture the pool liner or cause injury.
- Open the carton containing the liner, joints, legs, etc., very carefully as this carton can be used to store the pool during the winter months or when not in use.
- Take out the ground cloth (7) (optional) and spread it over the cleared area. Then take out the liner (5) and spread it out over the ground cloth, with the drain valve directed towards the draining area. Place the drain valve away from the house. Allow the sun to

warm up the liner before inserting the beams (4) into the sleeve openings.

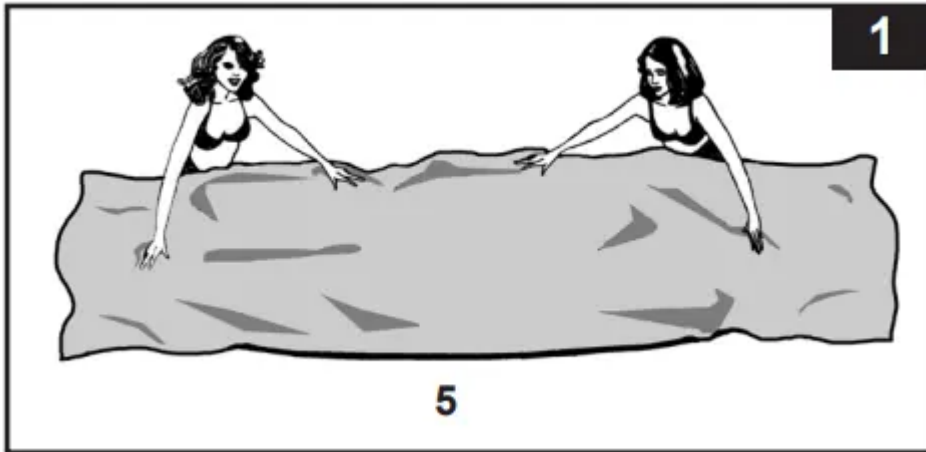

**IMPORTANT:** Always set up the pool unit with at least 2 persons. Do not drag the liner across the ground as this can cause liner damage and pool leakage (see drawing 1).

- During the setup of this pool liner, point the hose connections or openings in the direction of the electric power source. The outer edge of the pool should be within reach of the pump's electrical connection.

## 2. Horizontal beams assembly

- The frame pool's legs (2) and beams (4) fall into two groups. The larger diameters are the horizontal beams that are slid (pushed) into the sleeve openings at the top of the liner. The smaller diameters are the vertical legs. Both these legs and beams fit into the T-joints (1).

**NOTE:** Sprinkle some talcum powder over the horizontal beams before sliding them into the pool liner sleeve. This will make removal of the beams from the liner easier during the disassembly of the pool.

- Starting at any location, but always working in the same direction, push the horizontal beam into the sleeve. Once the beam is centered take one of the T-joints and attach the joint to one end of the beam. Push the beam firmly into the T-joint. Repeat this procedure in a circular fashion until all the beams and joints have been connected (see drawings 2.1 & 2.2).

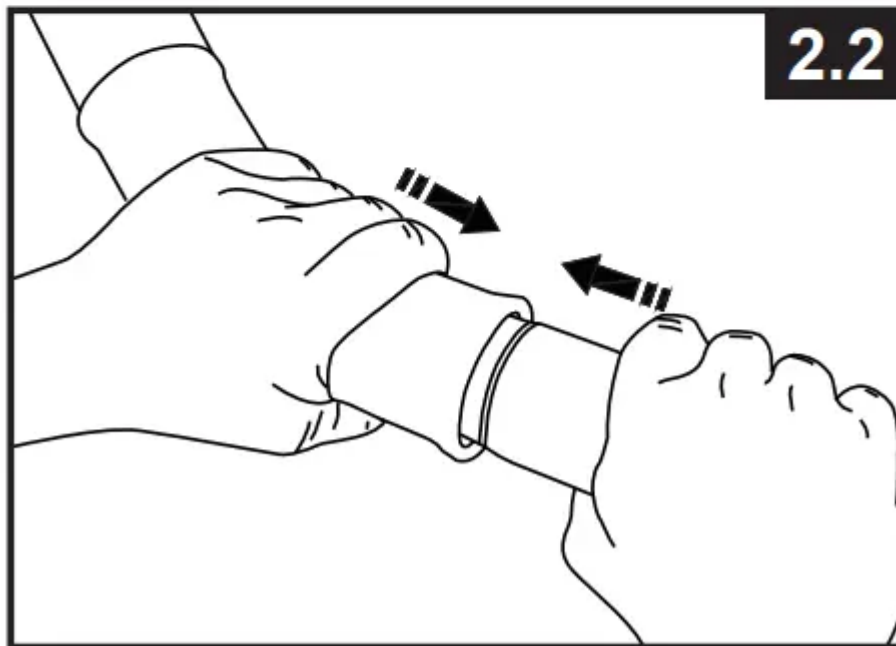
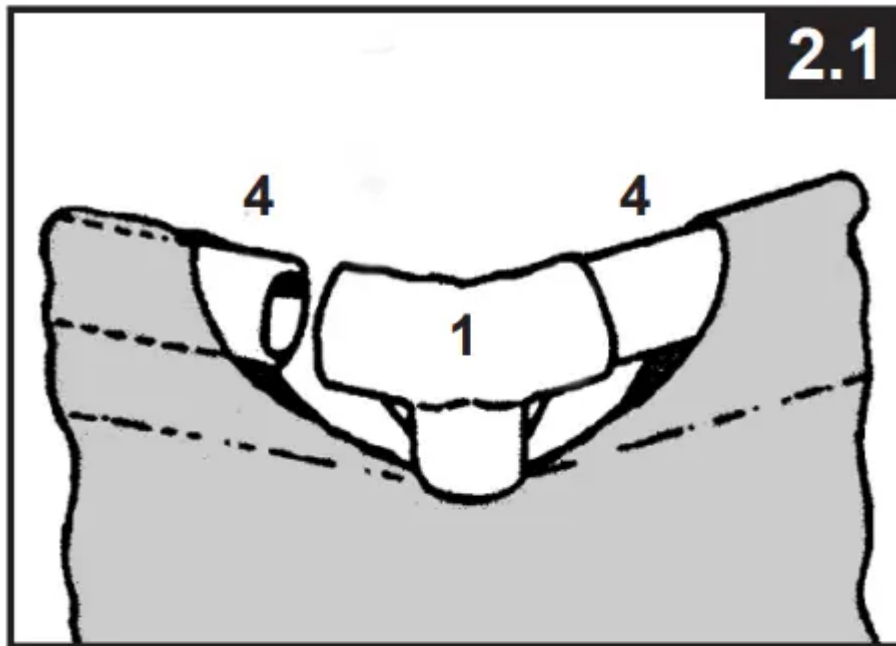

**NOTE:** It's important to start from one location and work in the same direction until the last attachment. Do not start from multiple locations as this will make the connections difficult for the last few beams and joints.

The last joint connection may be difficult to complete. You can do it though, if you first simultaneously raise the last joint and beam about 2 inches (5 cm). Now insert the beam into the joint while lowering the pieces into position. The beam will easily slide into the joint (see drawing 2.3). Ensure that the last joint is fully connected before proceeding to connecting the legs.

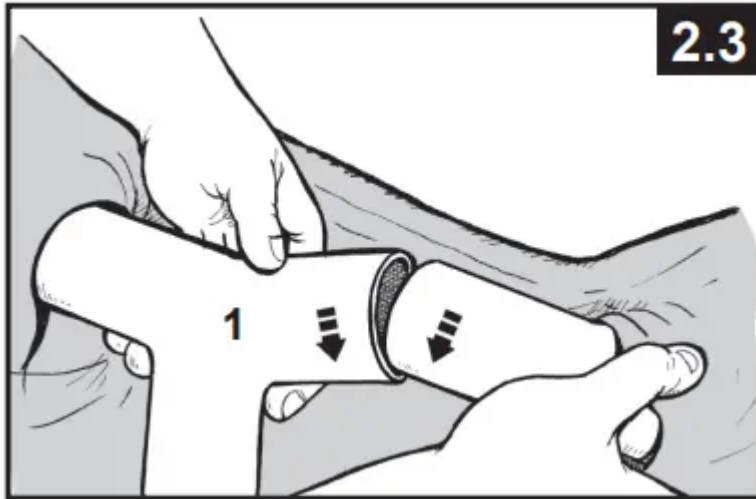

### 3. Vertical legs assembly

- Attach the leg's end cap (3) to the bottom of each leg (2) first. With the beams and T-joints assembly resting on the ground, slide one vertical leg into the belt loop located in the middle of the pool liner and insert the top of the leg into the bottom of the T-joint (1) (see drawing 3.1). Continue the process with all the vertical legs.

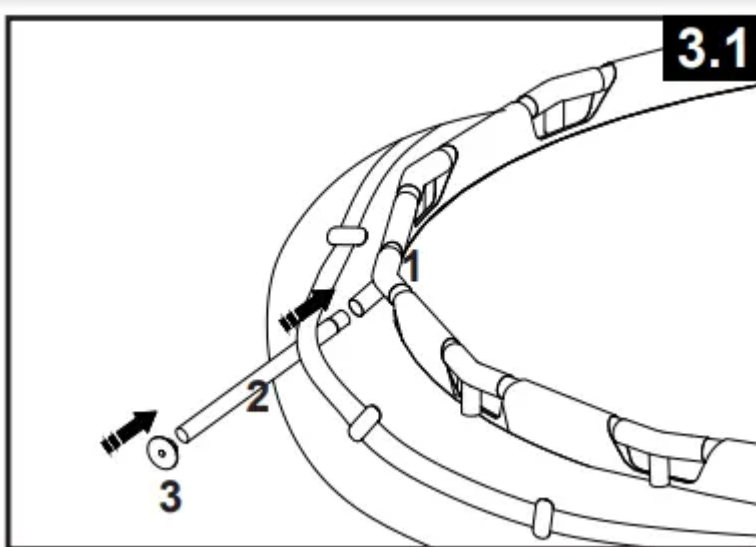

- Lift the beams assembly and make sure all the legs are in a vertical position (see drawing 3.2). Push all the T-joints downward to ensure they are firmly connected to the

legs.

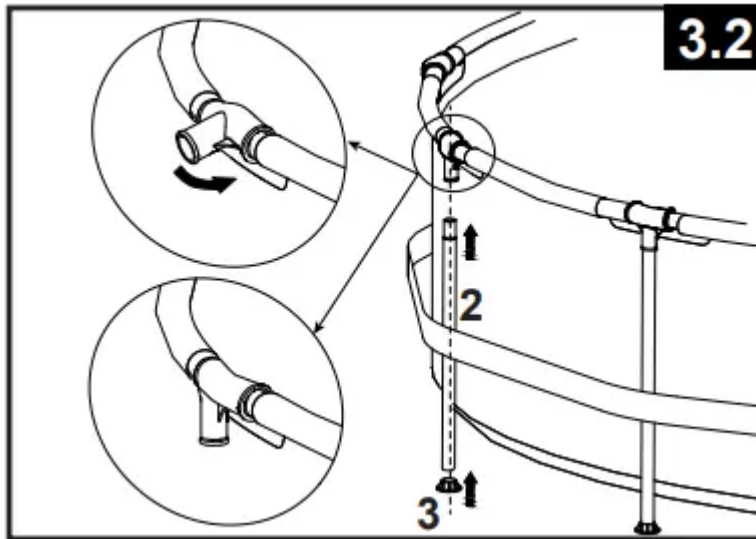

- Pull gently, in an outward direction, the bottom of the leg making sure the leg is vertical and perpendicular to the level ground.

#### 4. Filling of the pool

- The following applies to pool liners with hose connectors (16' (488 cm) & below pools). If the pool was purchased without a filter pump, insert the strainer hole plugs (8) into the black filter pump outlets. Do this from the inside of the pool so that water will not run out when filling it. If the pool was purchased with a filter pump, read the Krystal Clear™ Filter Pump Manual first and then proceed to next installation step.
- Before filling the pool with water, ensure that the drain plug inside the pool is closed and that the drain cap on the outside is screwed on tightly. Fill the pool with no more than 1 inch (2.5 cm) of water. Check to see whether the water is level.

**IMPORTANT: If the water in the pool flows to one side, the pool is not completely level.**

**Setting up the pool on unlevel ground will cause the pool to tilt resulting in the sidewall material bulging and a potential collapse of the pool. If the pool is not completely level, you must drain the pool, level the area or move the pool to a different area that is level, and re-fill the pool, following the above directions.**

- Smooth out the bottom liner wrinkles (from inside the pool) by pushing out where the pool floor and pool sides meet. Or, (from outside pool) reach under the side of the pool, grasp the pool floor and pull in an outward direction. If the ground cloth is causing the wrinkles, have 2 people pull from opposite sides to remove all wrinkles. Use the properly assembled pool ladder when entering or exiting the pool during this process. Also make sure all the legs are vertical and perpendicular to the ground.
- Fill the pool with water up to just below the sleeve line see drawing 4).

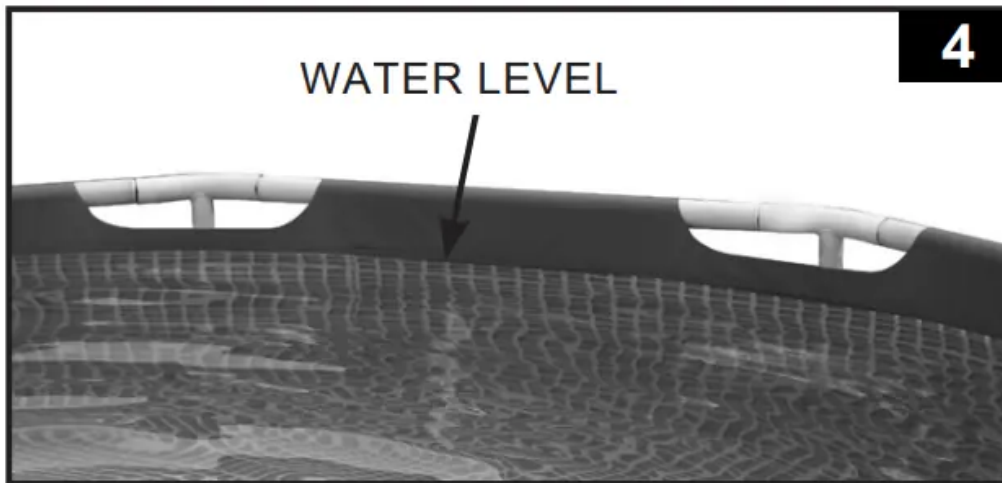

## 5. Posting aquatic safety signs

Select a highly visible area near the pool to post the Danger

No Diving or Jumping sign included later in this manual.

## GENERAL AQUATIC SAFETY

**Water recreation is both fun and therapeutic. However, it involves inherent risks of injury and death. To reduce your risk of injury, read and follow all product, package and package insert warnings and instructions. Remember, however, that product warnings, instructions and safety guidelines cover some common risks of water recreation, but do not cover all risks and dangers.**

**Assign an adult to be responsible for watching children in the pool. Give this person a “water watcher” tag and ask that they wear it the entire time they are in charge of supervising children in the pool. If they need to leave for any reason, ask this person to pass the “water watcher” tag and the supervision responsibility to another adult.**

For additional safeguards, also familiarize yourself with the following general guidelines as well as guidelines provided by nationally recognized Safety

### **Organizations:**

- Demand constant supervision. A competent adult should be appointed as a “lifeguard” or water watcher, especially when children are in and around the pool.
- Learn to swim.
- Take the time to learn CPR and first aid.
- Instruct anyone who is supervising pool users about potential pool hazards and about the use of protective devices such as locked doors, barriers, etc.
- Instruct all pool users, including children what to do in case of an emergency.

- Always use common sense and good judgement when enjoying any water activity.
- Supervise, supervise, supervise.

## **POOL MAINTENANCE & CHEMICALS**

### **Water maintenance**

The maintenance of a proper water balance through appropriate use of sanitizers is the single most important factor in maximizing the life and appearance of the liner as well as ensuring clean, healthy and safe water. Proper technique is important for water testing and treating the pool water. See your pool professional for chemical, test kits and testing procedures. Be sure to read and follow the written instructions from the chemical manufacturer.

1. Never let chlorine come in contact with the liner if it is not completely dissolved. Dissolve granular or tablet chlorine first in a bucket of water, then add it to the pool water. Likewise with liquid chlorine; mix it immediately and thoroughly with the pool water.
2. Never mix chemicals together. Add the chemicals to the pool water separately. Thoroughly dissolve each chemical before adding another one to the water.
3. An Intex pool skimmer and an Intex pool vacuum are available to assist in maintaining clean pool water. See your pool dealer for these pool accessories.
4. Do not use a pressure washer to clean the pool.

## **POOL MAINTENANCE & DRAINAGE**

**EXCESSIVE RAIN: To avoid damage to the pool and over filling, immediately drain rain water that causes the water level to be higher than the maximum.**

### **How to Drain Your Pool and Long Term Storage**

1. Check local regulations for specific directions regarding disposal of swimming pool water.
2. Check to make sure that the drain plug inside the pool is plugged in place.
3. Remove the cap from the drain valve on the outside pool wall.
4. Attach the female end of the garden hose to the drain connector (9).
5. Place the other end of the hose in an area where the water can be safely drained away from the house and other nearby structures.
6. Attach the drain connector to the drain valve. NOTE: The drain connector will push the drain plug open inside the pool and water will start to drain immediately.
7. When the water stops draining, start lifting the pool from the side opposite the drain, leading any remaining water to the drain and emptying the pool completely.
8. Disconnect hose and adapter when finished.

9. Re-insert drain plug in drain valve on inside of pool for storage.
10. Replace drain cap on outside of pool.
11. Reverse set-up instructions to disassemble the pool, and remove all connecting parts.
12. Be sure that the pool and all parts are completely dry before storage. Air dry the liner in the sun until completely dry before folding (see drawing 5). Sprinkle some talcum powder to prevent the vinyl from sticking together and to absorb any residual moisture.
13. Create a square shape. Starting at one side, fold one-sixth of liner in on itself twice. Do the same on the opposite side (see drawings 6.1 & 6.2).
14. Once you have created two opposing folded sides, simply fold one over the other like closing a book (see drawings 7.1 & 7.2).
15. Fold the two long ends to the middle (see drawing 8).
16. Fold one over the other like closing a book and finally compact the liner (see drawing 9).
17. Store the liner and accessories in a dry, temperature controlled, between 32 degrees Fahrenheit (0 degrees Celsius) and 104 degrees Fahrenheit (40 degrees Celsius), storage location.
18. The original packing can be used for storage.

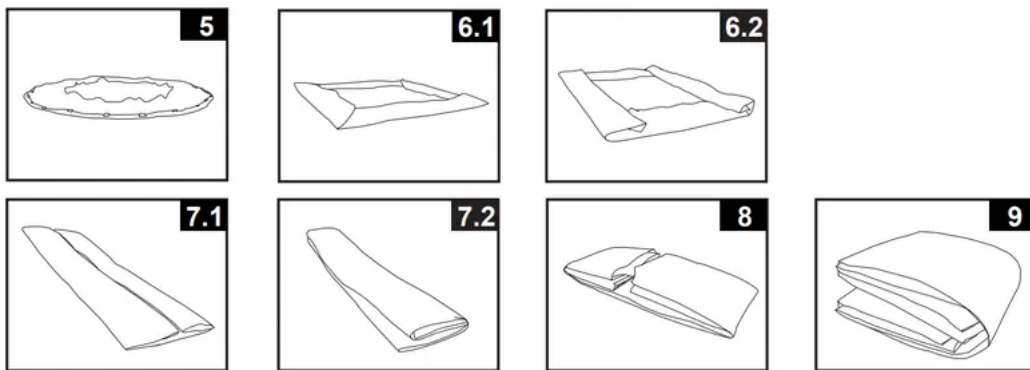

## WINTER PREPARATIONS

### Winterizing your Above Ground Pool

After usage, you can easily empty and store away your pool in a safe place. You must drain, disassemble and properly store the pool when the temperature drops below 41 degrees Fahrenheit (5 degrees Celsius) to prevent ice damage to the pool and related components. Ice damage can result in sudden liner failure or pool collapse. Also see the section “How To Drain Your Pool”.

Should temperatures in your area not drop below 41 degrees Fahrenheit (5 degrees Celsius), and you choose to leave your pool out, prepare it as follows:

1. Clean the pool water thoroughly. If the type is an Easy Set Pool or an Oval Frame Pool, make sure that the top ring is properly inflated.

2. Remove the skimmer (if applicable) or any accessories attached to the threaded strainer connector. Replace strainer grid if necessary. Be sure all accessories parts are clean and completely dry before storage.
3. Plug the Inlet and Outlet fitting from the inside of the pool with the plug provided (sizes 16' and below). Close the Inlet and Outlet Plunger Valve (sizes 17' and above).
4. Remove the ladder (if applicable) and store in a safe place. Be sure the ladder is completely dry before storage.
5. Remove the hoses that connect the pump and filter to the pool.
6. Add the appropriate chemicals for the winter period. Consult your local pool dealer as to which chemicals you should use and how to use them. This can vary greatly by region.
7. Cover pool with Intex Pool Cover. **IMPORTANT NOTE: INTEX POOL COVER IS NOT A SAFETY COVER.**
8. Clean and drain the pump, filter housing and hoses. Remove and discard the old filter cartridge. Keep a spare cartridge for the next season.
9. Bring pump and filter parts indoors and store in a safe and dry area, preferably between 32 degrees Fahrenheit (0 degrees Celsius) and 104 degrees Fahrenheit (40 degrees Celsius).

# TROUBLESHOOTING



PROBLEM	DESCRIPTION	CAUSE	SOLUTION
<b>ALGAE</b>	<ul style="list-style-type: none"> <li>• Greenish water.</li> <li>• Green or black spots on pool liner.</li> <li>• Pool liner is slippery and/or has a bad odor.</li> </ul>	<ul style="list-style-type: none"> <li>• Chlorine and pH level need adjustment.</li> </ul>	<ul style="list-style-type: none"> <li>• Super chlorinate with shock treatment. Correct pH to your pool store's recommended level.</li> <li>• Vacuum pool bottom.</li> <li>• Maintain proper chlorine level.</li> </ul>
<b>COLORED WATER</b>	<ul style="list-style-type: none"> <li>• Water turns blue, brown, or black when first treated with chlorine.</li> </ul>	<ul style="list-style-type: none"> <li>• Copper, iron or manganese in water being oxidized by the added chlorine.</li> </ul>	<ul style="list-style-type: none"> <li>• Adjust pH to recommended level.</li> <li>• Run filter until water is clear.</li> <li>• Replace cartridge frequently.</li> </ul>
<b>FLOATING MATTER IN WATER</b>	<ul style="list-style-type: none"> <li>• Water is cloudy or milky.</li> </ul>	<ul style="list-style-type: none"> <li>• "Hard water" caused by a too high pH level.</li> <li>• Chlorine content is low.</li> <li>• Foreign matter in water.</li> </ul>	<ul style="list-style-type: none"> <li>• Correct the pH level. Check with your pool dealer for advice.</li> <li>• Check for proper chlorine level.</li> <li>• Clean or replace your filter cartridge.</li> </ul>
<b>CHRONIC LOW WATER LEVEL</b>	<ul style="list-style-type: none"> <li>• Level is lower than on</li> </ul>	<ul style="list-style-type: none"> <li>• Rip or hole in pool liner or hoses.</li> </ul>	<ul style="list-style-type: none"> <li>• Repair with patch kit.</li> <li>• Finger tighten all caps.</li> </ul>



	previous day.		<ul style="list-style-type: none"> <li>• Replace the hoses.</li> </ul>
<b>SEDIMENT ON POOL BOTTOM</b>	<ul style="list-style-type: none"> <li>• Dirt or sand on pool floor.</li> </ul>	<ul style="list-style-type: none"> <li>• Heavy use, getting in and out of pool.</li> </ul>	<ul style="list-style-type: none"> <li>• Use Intex pool vacuum to clean bottom of pool.</li> </ul>
<b>SURFACE DEBRIS</b>	<ul style="list-style-type: none"> <li>• Leaves, insects etc.</li> </ul>	<ul style="list-style-type: none"> <li>• Pool too close to trees.</li> </ul>	<ul style="list-style-type: none"> <li>• Use Intex pool skimmer.</li> </ul>

<b>PROBLEM</b>	<b>CAUSE</b>	<b>SOLUTION</b>
<b>POOL INLET AIR ADAPTOR LEAKING</b>	<ul style="list-style-type: none"> <li>• Hose clamps are not well-fitted.</li> </ul>	<ul style="list-style-type: none"> <li>• Tighten or reinstall hose clamps.</li> </ul>
<b>INLET TREADED AIR CONNECTOR LEAKING</b>	<ul style="list-style-type: none"> <li>• Plunger valve not well-fitted.</li> </ul>	<ul style="list-style-type: none"> <li>• Tighten or reinstall plunger valve.</li> </ul>
<b>AIR JET VALVE LEAKING</b>	<ul style="list-style-type: none"> <li>• Air jet valve is not tight and facing up.</li> <li>• Air jet valve internal seal blocked.</li> <li>• Air jet valve internal seal dirty.</li> <li>• Air jet valve broken.</li> </ul>	<ul style="list-style-type: none"> <li>• Tighten air jet valve and make sure it's facing up.</li> <li>• Turn ON or plug in the pump and run for few seconds, then turn OFF or unplug, repeat 3 times.</li> <li>• Remove air jet valve, flush dirt out with water and replace valve back.</li> <li>• Replace a new air jet valve.</li> </ul>

**Warning**

This content is compiled from multiple sources and is provided for reference purposes only. It may not be complete or fully applicable to all situations. If you are unable to resolve your issue, please contact the product manufacturer or an authorized service provider for official support.

---

Document generated by [ManualsFile](#)

