

PARTS & ACCESSORIES

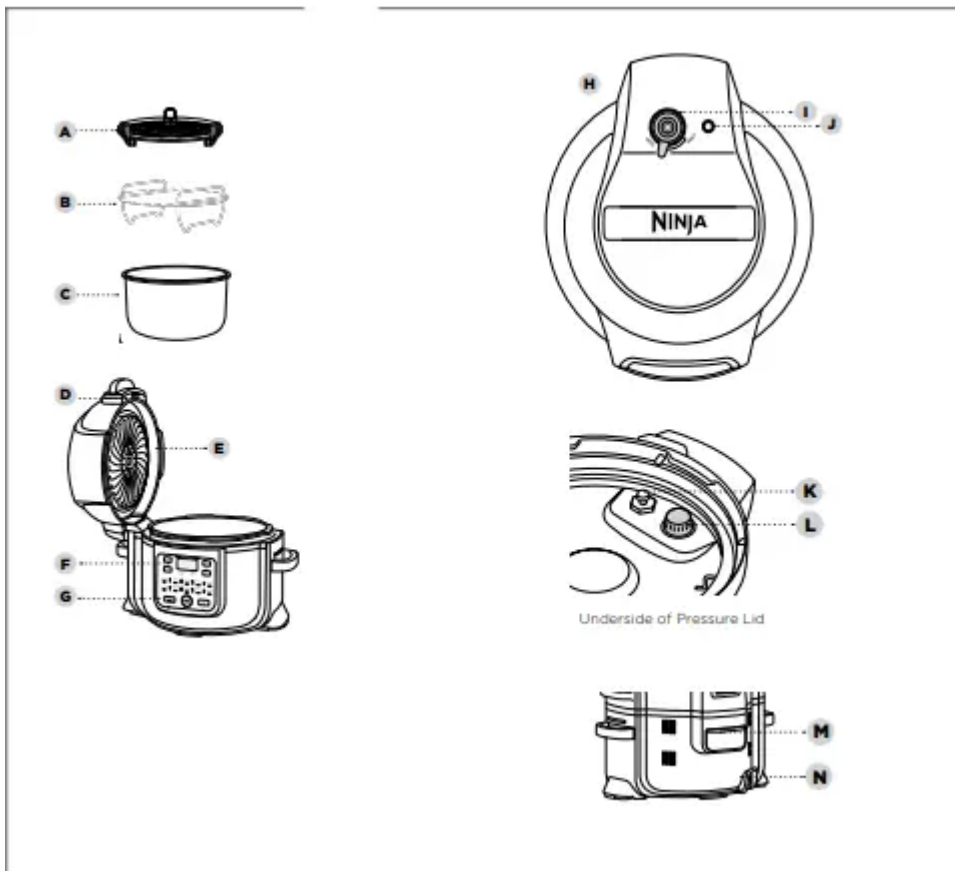

A Cook & Crisp™ Plate

B Nesting Broil Rack

C 5-Quart Removable Cooking Pot

D Crisping Lid

E Heat Shield

F Control Panel

G Cooker Base (power cord not shown)

H Pressure Lid

I Pressure Release Valve

J Float Valve

K Silicone Ring

L Anti-Clog Cap

M Air Outlet Vent

USING THE CONTROL PANEL



NOTE: Control panel may differ per model.

FUNCTION BUTTONS

PRESSURE: Cook food quickly while maintaining tenderness.

STEAM: Gently cook delicate foods at a high temperature.

SLOW COOK: Slow cook food at lower temperatures.

YOGURT: Pasteurize and ferment milk for creamy homemade yogurt.

SEAR/SAUTÉ: Use the unit as a stovetop for browning meats, sautéing veggies, simmering sauces, and more.

AIR CRISP: Give foods crispiness and crunch with little to no oil.

BAKE/ROAST: Use the unit as an oven for tender meats, baked treats, and more.

BROIL: Use to caramelize and brown your food.

DEHYDRATE: Dehydrate meats, fruits, and vegetables for healthy snacks.

SOUS VIDE: French for “under vacuum,” this function slow cooks food sealed in a plastic bag in an accurately regulated low-temperature water bath.

KEEP WARM: After pressure cooking, steaming, or slow cooking, the unit will automatically switch to Keep Warm mode and start counting up. Keep Warm will stay on for 12 hours, or you may press KEEP WARM to turn it off. Keep Warm mode is not intended to reheat food, but to keep it warm at a food-safe temperature.

OPERATING BUTTONS

TEMP arrows: Use the up and down TEMP arrows to adjust the cook temperature and/or pressure level.

TIME arrows: Use the up and down TIME arrows to adjust the cook time.

NOTE: The temperature and time can be adjusted anytime during cooking by using the up and down TEMP and TIME arrows. The unit will then resume at those settings.

START/STOP button: Press the START/STOP button after selecting your temperature (or pressure) and time to start cooking. Pressing this button while the unit is cooking will stop the current function.

POWER button: The Power button turns the unit on and off and stops all cooking modes

BEFORE FIRST USE

1. Remove and discard any packaging material, promotional labels, and tape from the unit.
2. Please pay particular attention to operational instructions, warnings, and important safeguards to avoid any injury or property damage.
3. Wash the pressure lid, silicone ring, removable cooking pot, Cook & Crisp™ Plate, and condensation collector in hot, soapy water, then rinse and dry thoroughly. NEVER clean the cooker base in the dishwasher. Inspect the pressure lid to ensure there is no debris blocking the valves.
4. The silicone ring is reversible and can be inserted in either direction. Insert the silicone ring around the outer edge of the silicone ring rack on the underside of the lid. Ensure it is fully inserted behind the silicone ring rack



INSTALLING THE CONDENSATION COLLECTOR

The condensation collector comes installed in the unit. Slide it out to remove for washing after each use.



NOTE: Prior to each use, make sure the silicone ring is well seated in the silicone ring rack and the anti-clog cap is mounted properly on the pressure release valve.

REMOVING & REINSTALLING THE ANTI-CLOG CAP

Make sure that the anti-clog cap is in the correct position before using the pressure lid. The anti-clog cap protects the inner valve of the pressure lid from clogging and protects users from potential food splatters. It should be cleaned after every use with a cleaning brush. To remove, hold the anti-clog cap between your thumb and bent index finger, then rotate your wrist clockwise to remove

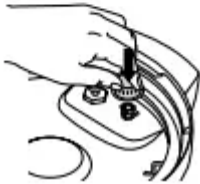
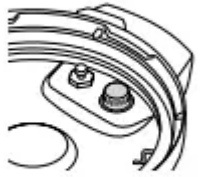

SWAP THE TOP

The two lids allow you to seamlessly transition between all your favorite cooking methods. Use the pressure lid to tenderize, then use the crisping lid to crisp up your food.

USING THE CRISPING LID

The crisping lid is permanently attached to the unit by a hinge. The lid can be opened when using the AIR CRISP and BAKE/ROAST functions, allowing you to check on or toss ingredients. When the lid is opened, cooking will stop and the timer will pause. When the lid is closed, cooking and the timer will resume.

USING THE COOKING FUNCTIONS WITH THE CRISPING LID

To turn on the unit, plug the power cord into a wall outlet, then press the Power button.

Air Crisp

1 With the pot installed, place the Cook & Crisp™ Plate into the pot.



2 Press the AIR CRISP button. The default temperature setting will display. Use the up and down TEMP arrows to set a temperature between 300°F and 400°F.

NOTE: It is recommended to let the unit preheat for 5 minutes before adding ingredients. If preheating, before step 4, close the lid, and press the START/STOP button to begin

3 Use the up and down TIME arrows to set the cook time in minute increments up to 1 hour.



4 Add ingredients to the pot. Close the lid and press the START/STOP button to begin cooking.

5 During cooking, you can open the lid and toss ingredients with silicone-tipped tongs for even browning as needed. When done, close lid. Cooking will automatically resume after lid is closed.



6 When cook time is complete, the unit will beep and display “End”.



Bake/Roast

1 Place ingredients in the pot or into the accessory called for in the recipe (then place accessory in the pot). Close the lid and press the START/STOP button to begin cooking.

2 Press the BAKE/ROAST button. The default temperature setting will display. Use the up and down TEMP arrows to set a temperature between 250°F and 400°F.



3 Use the up and down TIME arrows to set the cook time in 1-minute increments up to 1 hour, and in 5-minute increments from 1 hour to 4 hours



NOTE: If running for less than one hour the clock will count down by minutes and seconds. If running for more than one hour, the clock will count down by minutes only.

NOTE: It is recommended to let the unit preheat for 5 minutes before adding ingredients. If preheating, before step 3, close the lid, and press the START/STOP button to begin.

4 When cook time is complete, the unit will beep and display “End”.

Broil

1 Place the nesting broil rack in the pot and follow directions per recipe.



2 Place ingredients on the rack, then close the lid.



3 Press the BROIL button.



NOTE: There is no temperature adjustment when using the Broil function.

4 Use the up and down TIME arrows to set the cook time in minute increments up to 30 minutes.



5 Press the START/STOP button to begin cooking.



6 When cook time is complete, the unit will beep and display “End”.

Dehydrate

NOTE: The DEHYDRATE function is not included on all models

1 Place the ingredients on the bottom of the Cook & Crisp™ Plate.



2 Press the DEHYDRATE button. The default temperature setting will display. Use the up and down TEMP arrows to choose a temperature between 105°F and 195°F.



3 Use the up and down TIME arrows to set the cook time in 15-minute increments up to 12 hours.



4 Press the START/STOP button to begin dehydrating.



5 When cook time is complete, the unit will beep.

NOTE: For five levels of capacity, use the dehydrating rack* directly in the cooking pot.

NOTE: To reduce the risk of injury from unintended contact with hot foods, liquids and steam when pressure cooking, you must review and follow all warnings on pages 2–5. Failure to follow these safeguards increases your risk of experiencing a burn.

FAMILIARIZING YOURSELF WITH PRESSURE COOKING

In order to familiarize yourself with pressure cooking, it is highly recommended for firsttime users to do an initial run.

1 Place the pot in the cooker base and add 2 cups room-temperature water to the pot.



2 Assemble the pressure lid by aligning the arrow on the front of the lid with the arrow on the front of the cooker base. Then turn the lid clockwise until it locks into place.



3 Make sure the pressure release valve on the lid is in the SEAL position.



4 Press the PRESSURE button, the unit will default to high (Hi) pressure. Set the time to 2 minutes and press the START/STOP button to begin.

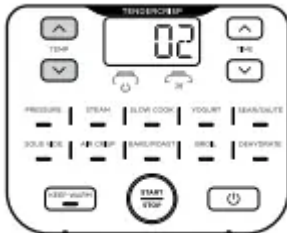

5 The unit will begin building pressure, indicated by the rotating lights. The unit will begin counting down when it is fully pressurized.

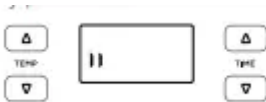

6 When the countdown is finished, the unit will beep, automatically switch to Keep Warm mode, and begin counting up.



7 Turn the pressure release valve to the VENT position to quick release the pressurized steam. A quick burst of steam will spurt out of the pressure release valve. When steam is completely released and the float valve drops down, the unit will be ready to open.



NATURAL PRESSURE RELEASE VS. QUICK PRESSURE RELEASE

Natural Pressure Release: Once pressure cooking is complete, the pressure will start to naturally release as the unit cools down. During this time, the unit will switch to Keep Warm mode. When natural pressure release is complete, the float valve will drop down.

NOTE: Press the KEEP WARM button if you would like to turn Keep Warm mode off.

Quick Pressure Release: Use ONLY when called for in a recipe. When cooking is complete, the unit will switch to Keep Warm mode. Turn the pressure release valve to the VENT position to instantly release pressure through the valve. When quick pressure release is complete the float valve will drop down. Even after releasing pressure, some steam will remain in the unit and will escape when the lid is opened. Lift and tilt it away from you, making sure no condensation drips into the cooker base.



NOTE: At any time during the natural release process, you can switch to quick release by turning the pressure release valve to the VENT position

PRESSURIZING

As pressure builds in the unit, the control panel will display progress bar. Pressurizing time varies, depending on the amount of ingredients and liquid in the pot. As the unit pressurizes, the lid will lock as a safety measure, and it will not unlock until pressure is released. Once the unit has reached full pressure. The cooking cycle will begin and the timer will start counting down

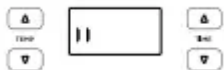

INSTALLING & REMOVING THE PRESSURE LID

Place the pressure lid on top of the unit with the [] on the lid and the [] on the base lined up evenly. Turn the lid clockwise until it locks in place. To unlock the pressure lid, turn it counterclockwise. Lift the lid at an angle to prevent splatter. Do not lift the lid straight up.

NOTE: The pressure lid will not unlock until the unit is completely depressurized.

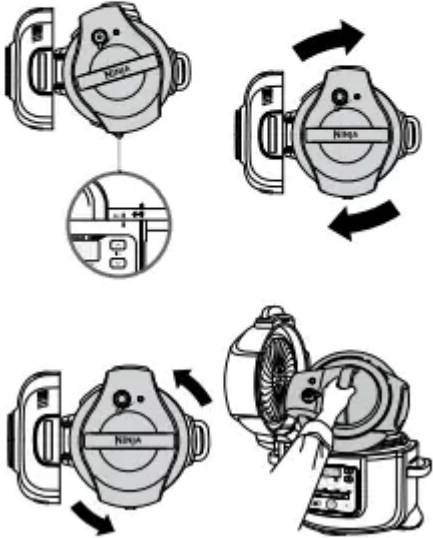

USING THE COOKING FUNCTIONS WITH THE PRESSURE LID

To turn on the unit, plug the power cord into a wall outlet, then press the Power button. Install the cooking pot in the cooker base before starting a function.

Pressure

1 Install the cooking pot in the cooker base. Place ingredients and at least 1 /2 cup of liquid in the pot, including an accessory if your recipe calls for it. Do not exceed the line marked PRESSURE MAX when pressure cooking.

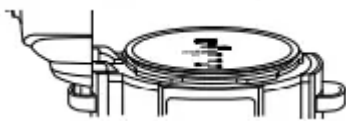

NOTE: When cooking rice, beans, or other ingredients that expand, do not fill the pot more than halfway

2 Install the pressure lid (see section titled Installing & Removing the Pressure Lid).



3 Press the PRESSURE button. The default pressure level will display. Use the up and down TEMP arrows to select either Hi or Lo.



NOTE: If running for less than 1 hour the clock will count down by minutes and seconds. If running for more than an hour, the clock will count down by minutes only.

4 Use the up and down TIME arrows to set the cook time 1-minute increments up to 1 hour, and in 5-minute increments from 1 hour to 4 hours.



5 Press the START/STOP button. The display will show progress bars during this time. When the unit reaches the proper temperature, the time you set will begin counting down.

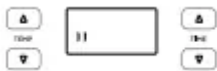

6 When cook time is complete, the unit will beep, automatically switch to Keep Warm mode, and start counting up from 00:00.



NOTE: After cooking is complete, you may press the KEEP WARM button to turn the Keep Warm mode off.

7 Let the unit naturally release pressure or, if the recipe instructs, turn the pressure release valve to the VENT position, quickly releasing steam through the valve.



Steam

1 Install the cooking pot in the cooker base. Add at least 1 cup of liquid (or the amount stated in your recipe) to the pot, then place the Cook & Crisp™ Plate with ingredients in the pot.



2 Follow the steps provided earlier to install the pressure lid. Turn the pressure release valve to the VENT position.



3 Press the STEAM button. Use the up and down TIME arrows to set the cook time in minute increments up to 30 minutes.



NOTE: There is no temperature adjustment available or necessary when using the Steam function

4 Press the START/STOP button.

5 The unit will automatically preheat to bring the steaming liquid to a boil. The display will show progress bars during this time. When the unit reaches the proper temperature, the time you set will begin counting down.

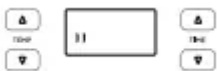

6 When cook time is complete, the unit will beep and automatically switch to Keep Warm mode. If the float valve pops up, wait for it to drop and then you can open the lid.



NOTE: After cooking is complete, you may press the KEEP WARM button to turn the Keep Warm mode off.

Slow Cook

1 Install the cooking pot in the cooker base. Place ingredients in the pot. DO NOT exceed the line marked MAX when slow cooking.

2 Install the pressure lid (see section titled Installing & Removing the Pressure Lid).



3 Press the SLOW COOK button. The default temperature setting will display. Use the up and down TEMP arrows to select either Slow Cook HIGH or LOW.



4 Use the up and down TIME arrows to set the cook time in 15-minute increments up to 12 hours.



5 Press the START/STOP button to begin cooking.

NOTE: The Slow Cook Hi (High) time setting may be adjusted anywhere between 4 and 12 hours; the Slow Cook Lo (low) time setting may be adjusted anywhere between 6 and 12 hours.

6 When cook time is complete, the unit will beep and automatically switch to Keep Warm mode.

NOTE: After cooking is complete, you may press the KEEP WARM button to turn the Keep Warm mode off.

CLEANING & MAINTENANCE



Cleaning: Dishwasher & Hand-Washing

The unit should be cleaned thoroughly after every use.

1. Unplug the unit from the wall outlet before cleaning.
2. NEVER put the cooker base in the dishwasher, or immerse it in water or any other liquid.
3. To clean the cooker base and the control panel, wipe them clean with a damp cloth.
4. The cooking pot, pressure lid, silicone ring, and Cook & Crisp™ Plate can be washed in the dishwasher.
5. The nesting broil rack is hand-wash ONLY.
6. The pressure lid, including the pressure release valve and anti-clog cap, can be washed with water and dish soap. DO NOT take apart the pressure release valve or float valve assembly.
7. To clean the crisping lid, wipe it down with a wet cloth or paper towel after the heat shield cools.
8. If food residue is stuck on the cooking pot or Cook & Crisp Plate, fill the pot with water and allow to soak before cleaning. DO NOT use scouring pads. If scrubbing is necessary, use a nonabrasive cleanser or liquid dish soap with a nylon pad or brush.
9. Air-dry all parts after each use.

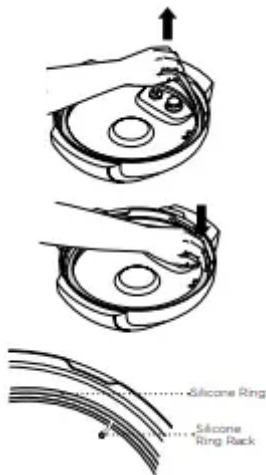

Removing & Reinstalling the Silicone Ring

To remove the silicone ring, pull it outward, section by section, from the silicone ring rack. The silicone ring is reversible and can be installed with either side facing up. To reinstall, press it down into the rack section by section.

After use, remove any food debris from the silicone ring and anti-clog cap.

Keep the silicone ring clean to avoid odor.

Washing it in warm, soapy water or in the dishwasher can remove odor. However, it is normal for it to absorb the smell of certain acidic foods. It is recommended to have more than one silicone ring on hand. You can purchase additional silicone rings on ninjaaccessories.com.

NEVER pull out the silicone ring with excessive force, as that may deform it and the rack and affect the pressure-sealing function. A silicone ring with cracks, cuts, or other damage should be replaced immediately.

TROUBLESHOOTING GUIDE

Why is my unit taking so long to come to pressure? How long does it take to come to pressure?

- Cooking times may vary based on the selected temperature, current temperature of the cooking pot, and temperature or quantity of the ingredients.
- Check to make sure your silicone ring is fully seated and flush against the lid. If installed correctly, you should be able to tug lightly on the ring to rotate it.
- Check that the pressure lid is fully locked, and the pressure release valve is in the SEAL position when pressure cooking.

Why is the time counting down so slowly?

- You may have set hours rather than minutes. When setting time, the display will show HH:MM and the time will increase/decrease in minute increments.

How can I tell when the unit is pressurizing?

- The rotating lights will display on the screen to indicate the unit is building pressure.

Progress bars are showing on the display screen when using the Pressure or Steam function.

- The progress bar indicates the unit is building pressure or preheating when using STEAM or PRESSURE. When the unit has finished building pressure, your set cook time will begin counting down.

There is a lot of steam coming from my unit when using the Steam function.

- It's normal for steam to release through the pressure release valve during cooking. Leave the pressure release valve in the VENT position for Steam, Slow Cook, and Sear/Sauté.

Why can't I take the pressure lid off?

- As a safety feature, the pressure lid will not unlock until the unit is completely depressurized. To release pressure, turn the pressure release valve to the VENT position to quickly release the pressurized steam. A quick burst of steam will spurt out of the pressure release valve. When the steam is completely released, the unit will be ready to open. To unlock the pressure lid, turn it counterclockwise. Lift the lid at an angle to prevent splatter. Do not lift the lid straight up.

Is the pressure release valve supposed to be loose?

- Yes. The pressure release valve's loose fit is intentional; it enables a quick and easy transition between SEAL and VENT and helps regulate pressure by releasing small amounts of steam during cooking to ensure great results. Please make sure it is turned as far as possible toward the SEAL position when pressure cooking and as far as possible toward the VENT position when quick releasing.

The unit is hissing and not reaching pressure.

- Make sure the pressure release valve is turned to the SEAL position. If you've done this and still hear a loud hissing noise, it may indicate your silicone seal is not fully in place. Press START/STOP to stop cooking, VENT as necessary, and remove the pressure lid. Press down on the silicone ring, ensuring it is fully inserted and lies flat under the ring rack. Once fully installed, you should be able to tug lightly on the ring to rotate it.

The unit is counting up rather than down.

- The cooking cycle is complete and the unit is in Keep Warm mode.

How long does the unit take to depressurize?

- The time it takes to release pressure depends on the quantity of food in the unit and can vary from recipe to recipe. Always ensure the float valve has dropped before trying to remove the lid. If the unit is taking longer than normal to depressurize, unplug the unit and wait until the float valve drops before removing the lid.

"ADD POT" error message appears on display screen.

- Cooking pot is not inside the cooker base. Cooking pot is required for all functions.

"OTHR LID" error message appears on display screen.

- The incorrect lid is installed for your desired cooking function. Place the pressure lid on the unit if you want to use the Pressure, Slow Cook, Steam, Sear/Sauté, or Keep Warm functions and ensure it is in the closed position.

"SHUT LID" error message appears on display screen.

- The crisping lid is open and needs to be closed for the selected function to start.

"TURN LID" error message appears on the display screen.

- The pressure lid is not fully installed. Turn the lid clockwise until it clicks for the selected cooking function to start.

"OPEN VENT" error message appears on display screen.

- When set to Slow Cook or Sear/Sauté, and the unit senses pressure building up, this message indicates the pressure release valve is in the SEAL position.
- Turn the pressure release valve to the VENT position and leave it there for the remainder of the cooking function.

- If you do not turn the pressure release valve to the VENT position within 5 minutes, the program will cancel and the unit will shut off.

"ADD WATR" error message appears on display screen when using the Steam function.

- The water level is too low. Add more water to the unit for the function to continue.

"ADD WATR" error message appears on display screen when using the Pressure function.

- Add more liquid to the cooking pot before restarting the pressure cook cycle.
- Make sure the pressure release valve is in the SEAL position.
- Make sure the silicone ring is installed correctly.

"ERR" message appears.

- The unit is not functioning properly. Please contact Customer Service at 1-877-646-5288. So we may better assist you, please register your product online at registeryourninja.com and have the product on hand when you call.

"ADD FOOD" message on screen when using the Sous Vide function.

- Preheating is complete and you can now place the resealable bags containing food in the water. Remove the pressure lid, add food, then reinstall pressure lid, ensuring the pressure release valve is in the VENT position.

Warning

This content is compiled from multiple sources and is provided for reference purposes only. It may not be complete or fully applicable to all situations. If you are unable to resolve your issue, please contact the product manufacturer or an authorized service provider for official support.