

DESCRIPTION OF THE APPLIANCE

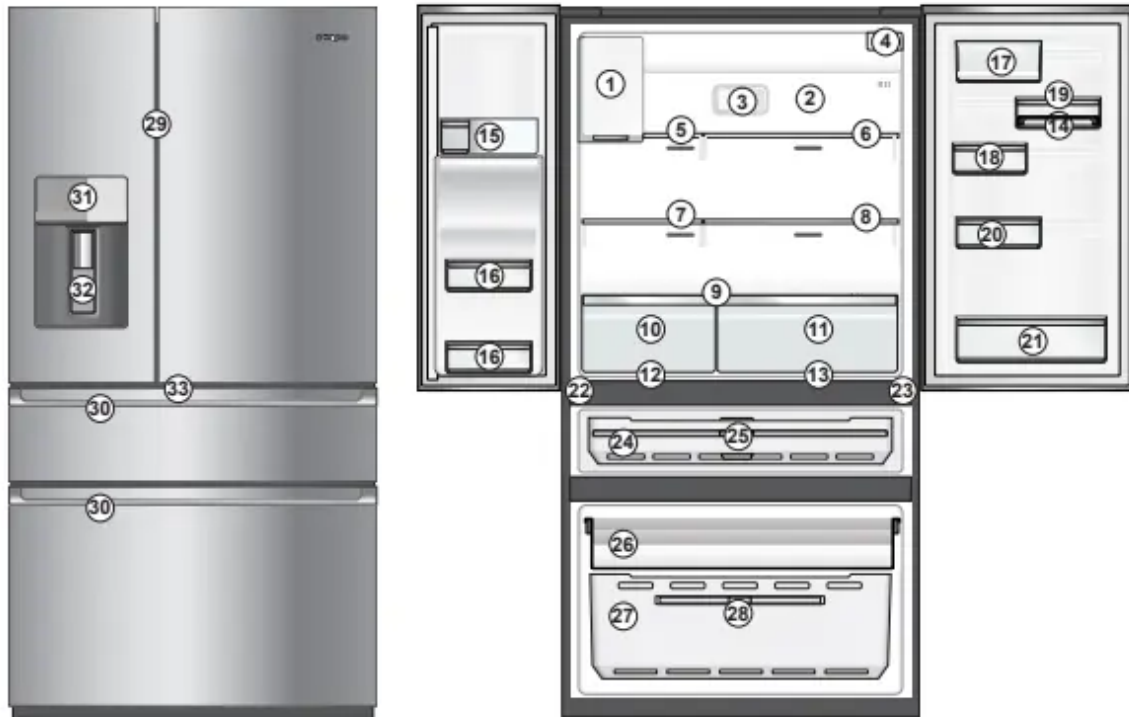

The details of the refrigerator feature:



- | | |
|--|---|
| <ol style="list-style-type: none"> 1. Ice Maker 2. Air distributor - Multiflow 3. Air filter 4. Water filter 5. Flip up glass shelf 6. Slide/fold glass shelf 7. Left Glass shelf 8. Right Glass shelf 9. Crisper shelf cover 10. Left crisper 11. Right crisper 12. Left Snack Zone compartment 13. Right Snack Zone compartment 14. Egg Tray 15. Upper fixed door bin 16. Left fixed door bin 17. FlexStor™ dairy bin | <ol style="list-style-type: none"> 18. Adjustable Door 1/3 bin 19. Adjustable Door 2/3 bin 20. Adjustable Expandable bin 21. Bottle storage bin 22. Adjustable left hinge 23. Adjustable right hinge 24. Drawer 25. Drawer divider 26. Upper freezer drawer 27. Lower freezer basket 28. Lower freezer basket divider 29. Refrigerator Door Handles 30. Drawer Door handles 31. Refrigerator/Freezer control panel 32. Water and Ice Dispenser Trigger 33. Drawer control panel |
|--|---|

ABOUT THE USER INTERFACE

External user interface

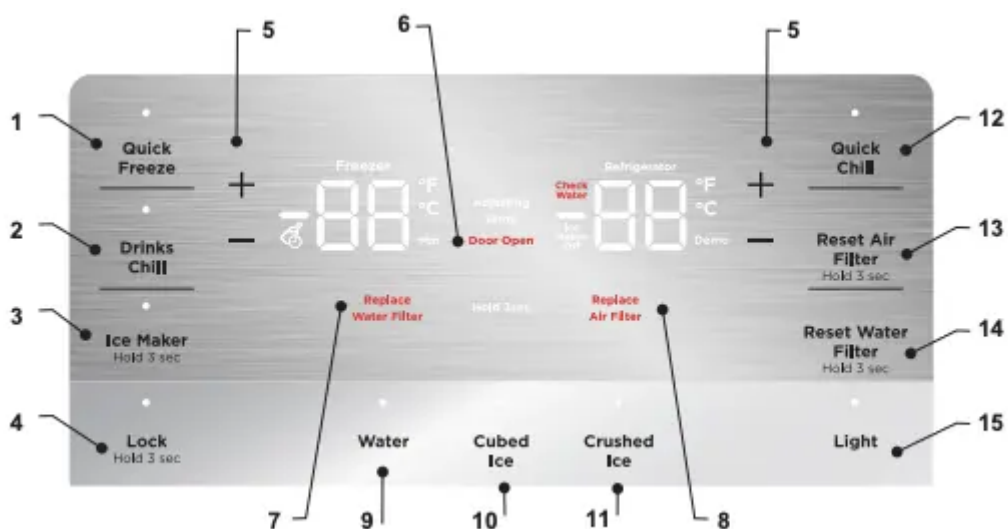

BUTTON/ ICON	DESCRIPTION	PRIMARY FUNCTION
1	Quick Freeze (on/off)	Activates a faster rate for freezing food in the freezer. Deactivates after 12 hours.
2	Drinks Chill	Quickly chills a drink inside the freezer compartment. Touch the Drinks Chill Key, a time value will display on the freezer temp display (in minutes) and can be changed using the +/- buttons. A tone will sound when the time has been input. Range is from 20-45 minutes in 5 minute intervals.
3	Ice Maker	When LED is lit, the ice maker is on. When ice maker is in OFF state, the indicator will blink when dispensing ice. Press and hold for 3 seconds to turn ice maker on/off.
4	Lock	Press and hold for 3 seconds to enable/disable. While in the locked state, you will not be able to change any settings on the display nor dispense ice and water. The indicator will flash and an audible warning tone is played
5	Adjusting Temp	Press either the + or - to adjust to desired temperature setting. Freezer temp - Control temperatures range From -23°C to -15°C. Refrigerator temp - Control temperatures range From +1°C to +7°C. How to change the °F/°C Mode: Press and hold for 5 seconds + and - on the refrigerator side. A tone will be heard. The display will then revert to either °F/°C mode
6	Door Open	Illuminates and sounds an alarm when the door is left open for 5 minutes or more. It stays illuminated as long as the door is open. Pressing any key will mute and reset the alarm.
7	Replace Water Filter	Display illuminates every 6 months or when filter needs replacing. Press and hold 'Reset Water Filter' for 3 seconds to reset.
8	Replace Air Filter	Display illuminates every 6 months or when filter needs replacing. Press and hold 'Reset Air Filter' for 3 seconds to reset.
9	Water	Press the "water" key to select water. An indicator light will be illuminated above the active feature.
10	Cubed Ice	Press the "cube" key to select cubed ice. An indicator light will be illuminated above the active feature.

11	Crushed Ice	Press the “crush” key to select crushed ice. An indicator light will be illuminated above the active feature.
12	Quick Chill	Quick chill is a faster rate for chilling food in the refrigerator compartment. Deactivates after 6 hours.
13	Reset Air Filter	After replacing filter, press and hold for 3 seconds to reset.
14	Reset Water Filter	After replacing filter, press and hold for 3 seconds to reset.
15	Lighting	Press the light button to turn on/off the dispenser light. If you press and hold it for 3 sec. it will toggle on/off the handles ambient lighting.

Internal user interface

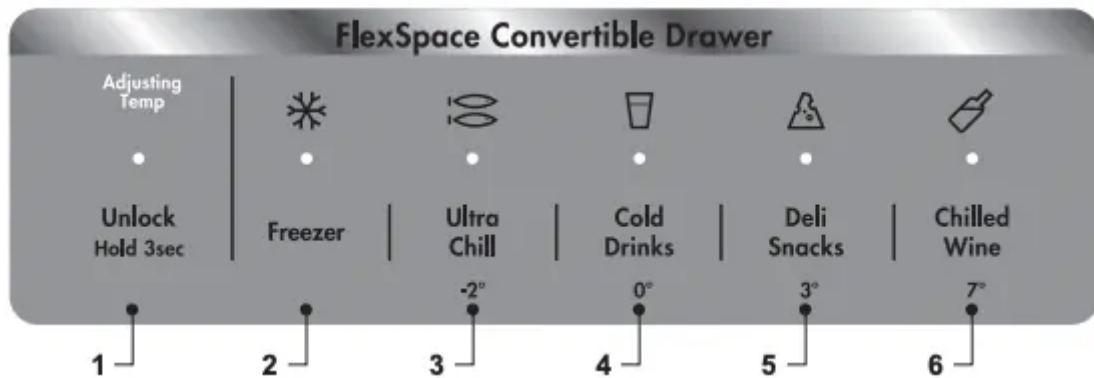

BUTTON/ ICON	DESCRIPTION	PRIMARY FUNCTION
1	Unlock	The interface will automatically lock after 3 seconds without any interaction. Press and hold 3 seconds to unlock the interface. A tone will sound to confirm your choice.
2	Freezer	Choosing Freezer will set drawer temperature to the same temperature as the freezer compartment. A tone will sound to confirm your choice.
3	Ultra Chill	Choosing Ultra Chill will set drawer temperature to -2°C. A tone will sound to confirm your choice.
4	Cold Drinks	Choosing Cold Drinks will set drawer temperature to 0°C. A tone will sound to confirm your choice.
5	Deli Snacks	Choosing Deli Snacks will set drawer temperature to 3°C. A tone will sound to confirm your choice.
6	Chilled Wine	Choosing Chilled Wine will set drawer temperature to 7°C. A tone will sound to confirm your choice.

Setting cooling temperatures

Note: The recommended settings for a product installed in a kitchen is 3°C for the fresh food compartment and -17°C for the freezer.

IMPORTANT If your product has food freezing in the fresh food compartment, increase the temperature setting 1 or 2 degrees Celsius. If you place food within 2 cm in front of the air ports, there may be the chance of freezing food.

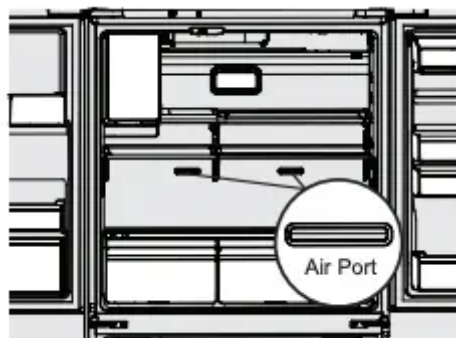

Note: Control features and alarms may vary by model.

Alerts and Alarms

Water Filter

When illuminated, the water filter needs to be replaced. Change the water filter every 6 months or when 454 litres of water has been dispensed. To reset, press and hold button for 3 seconds. Tone will sound once it has been reset.

Air Filter Installation

First operation the refrigerator need to installation the air filter which storage at crisper left side and follow installation method as below.

Carbon activated air filter

1. Remove plastic wrap.
2. Install filter according to your refrigerator's use&care guide.
3. Reset filter reminder light on your refrigerator.
4. Replace filter every 6 months.

When illuminated, air filter needs to be replaced. Change the air filter every 6 months. To reset, press and hold button for seconds. Tone will sounds once it has been reset.

Door Open

If a door has been left open for 5 minutes or more, an alarm will sound and the door open indicator will illuminate on the display. The alarm can be turned off by closing the door or pressing any key. Control panel will return to normal operation after the door is closed.

Error Tone

An alarm will sound if the user tries to make a selection that is not available.

Sabbath Mode

The Sabbath Mode is a feature that disables portions of the refrigerator and its controls in accordance with observance of the weekly Sabbath and religious holidays within the Orthodox Jewish community.

Sabbath Mode is turned ON and OFF by simultaneously pressing and holding both the "-" (freezer side) and "+" (refrigerator side) for five seconds. Other than the High Temp alarm, no audible sounds will occur until the user exits the Sabbath mode. The display shows "Sb" while in Sabbath mode.

In the Sabbath Mode, the High Temp alarm is active for health reasons. For example,

If the door is left ajar the High Temp alarm is activated. The refrigerator will function normally once the door is closed, without any violation of the Sabbath/Holidays. The High Temp alarm is permitted when cabinet temperature is outside the safe zone for 20 minutes. The alarm silences itself after 10 minutes while the High Temp icon stays lit until the Sabbath mode is exited.

Note: While in Sabbath Mode, neither the lights, dispenser, nor the control panel will work until Sabbath Mode is deactivated.

Refrigerator stays in Sabbath Mode after power failure recovery. It must be deactivated with the buttons on the control panel.

Although you have entered the Sabbath Mode, the ice maker will complete the cycle it had already initiated. The ice cube compartment will remain cold and new ice cubes can be made with standard trays.

USING YOUR REFRIGERATOR

AUTOMATIC ICE & WATER DISPENSER

Using the ice maker after installation

Before making ice for the first time, be sure to prime the water supply system. Air in new plumbing lines can result in two or three empty ice maker cycles. Furthermore, if the system is not flushed, the first ice cubes may be discolored or have an odd flavor.

Priming the water supply system

CAUTION

For proper dispenser operation, recommended water supply pressure should fall between 30 psi and 100 psi. Excessive pressure may cause the system to malfunction.

1. Begin filling the system by pressing and holding a drinking glass against the dispenser.
2. Keep the glass in this position until water comes out of the dispenser. It may take about 1½ minutes.
3. Continue dispensing water for about four minutes to flush the system and plumbing connections of any impurities (stopping to empty the glass as necessary).

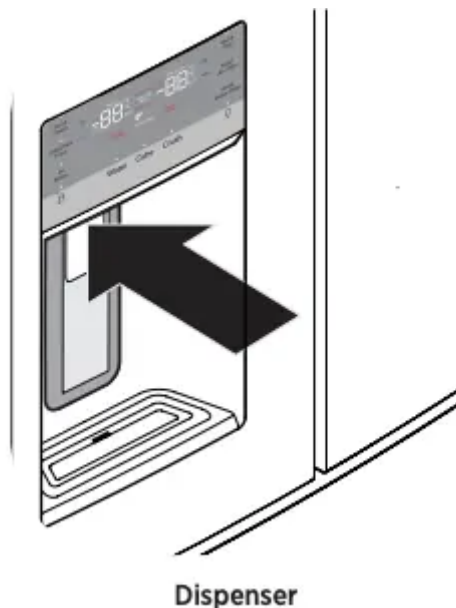

Note: The water dispenser has a built-in device that shuts off the water flow after two minutes of continuous use. To reset this shut-off device, simply release the dispenser paddle.

Only the first 26 ounces (750 ml) of dispensed water is chilled.

WARNING Flushing system about 2 minutes after period of non-use exceeding 30 days

Ice maker operation & care

After the refrigerator is installed properly and has cooled for several hours, the ice maker can produce ice within 24 hours. The ice maker will fill the ice bin from the rear. You must dispense some ice to force the ice forward in the bin. This will allow the bin to fill completely.

Ice Maker and Storage Bin Capacity

This ice maker should produce 1,2 to 1,5 Kg of ice per 24 hours. The ice bin will hold about Kg of ice.

Turning the ice maker on and off

IMPORTANT

Your ice maker is turned on at the factory so it can work as soon as you install your refrigerator. If you cannot connect a water supply, set the ice maker's On/Off feature to Off; otherwise, the ice maker's fill valve may make a loud chattering noise when it attempts to operate without water.

Ice production is controlled by the ice maker's On/Off feature on the control panel. Pressing the On/Off feature turns the ice maker on & off.

Note: The ice maker also has a built-in plastic signal arm that automatically stops ice production when the ice bin is full. This signal arm should not be used to manually stop the ice maker.

IMPORTANT

Turning off the ice maker simply disables ice making. You will still be able to dispense existing ice, and you will still be able to dispense water.

On occasion, unusually small ice cubes may be noticed in the bucket or in dispensed ice. This could occur in normal operation of the ice maker. If you start seeing these more frequently, it may be an indication of low water pressure, or that the water filter needs to be replaced. As the water filter nears the end of its useful life and becomes clogged with particles, less water is delivered to the ice maker during each cycle. Remember, if it has been six months or longer since you last changed your water filter, replace the water filter with a new one. Poor quality household water may require the filter to be changed more frequently.

Ice maker/dispenser tips

- If your refrigerator is not connected to a water supply or the water supply is turned off, turn off the ice maker as described in the previous section.
- The following sounds are normal when the ice maker is operating:

Motor running

Ice dropping into ice bin

Water valve opening or closing

Running water

- If you need a large quantity of ice at one time, it is best to get cubes directly from the ice bin.
- Ice cubes stored too long may develop an odd flavor. Empty the ice bin as explained below.
- When dispensing cubed ice, it is normal to have a small quantity of little pieces along with the whole cubes.
- To avoid splashing, dispense ice into your container before adding liquids.
- It is normal for ice to fill to the top of the ice bin.

CAUTION If the water supply to your refrigerator is softened, be sure the softener is properly maintained. Chemicals from a water softener can damage the ice maker.

Cleaning the ice maker

Clean the ice maker and ice bin at regular intervals, especially prior to vacation or moving.

1. Turn off the icemaker.
2. Remove the ice bin by pulling straight out.
3. Empty and carefully clean the ice bin with mild detergent. Do not use harsh or abrasive cleaners. Do not place in dishwasher. Rinse with clear water.
4. Allow the ice bin to dry completely before placing it back into the freezer.
5. Place ice bin back into position. Turn the ice maker on.

Remove and empty the ice bin if:

- An extended power failure (one hour or longer) causes ice cubes in the ice bin to melt and refreeze together after power is restored, jamming the dispenser mechanism.
- You do not use the ice dispenser frequently. Ice cubes will freeze together in the bin, jamming the dispenser mechanism.

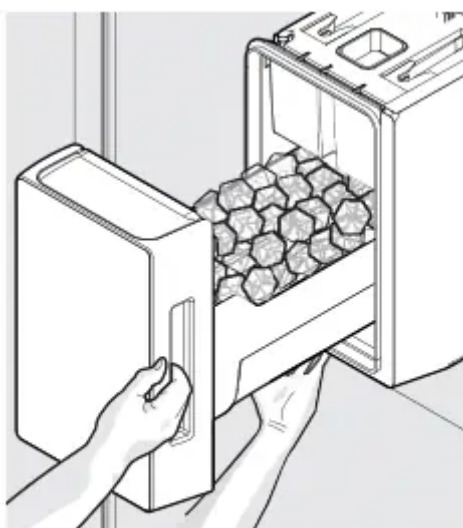

Removing Ice Bin

Remove the ice bin and shake to loosen the cubes or clean as explained above.

CAUTION NEVER use an ice pick or similar sharp instrument to break up the ice. This could damage the ice bin and dispenser mechanism. To loosen stuck ice, use warm water. Before replacing the ice bin, make sure it is completely dry

IMPORTANT When removing or replacing the ice bin, avoid rotating the auger in the ice bin. If the auger is accidentally rotated, you must realign the auger by turning it in 45 degree turns (see below) until the ice bin fits into place with the drive mechanism. If the auger is not properly aligned when replacing the ice bin, the refrigerator will not dispense ice. The fresh food door also may not close properly causing warm air to leak into the fresh food compartment.

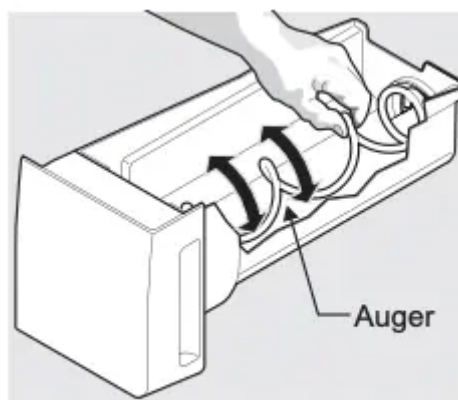

Adjusting the Ice Bin Auger

STORAGE FEATURES

CAUTION To avoid personal injury or property damage, handle tempered glass shelves carefully. Shelves may break suddenly if nicked, scratched, or exposed to sudden temperature change. Allow the glass shelves to stabilize to room temperature before cleaning. Do not wash in dishwasher.

You can easily adjust shelf positions in the fresh food compartments to suit your needs. The shelves have mounting brackets that attach to slotted supports at the rear of each compartment.

To change a shelf position:

1. Remove all food from shelf.
2. Lift the front edge up and pull the shelf out.
3. Replace by inserting the mounting bracket hooks into the desired support slots.
4. Lower the shelf and lock into position.

To adjust the flip shelf:

1. Remove food from shelf.
2. Lift the right side edge of shelf upwards and push to the left towards ice maker

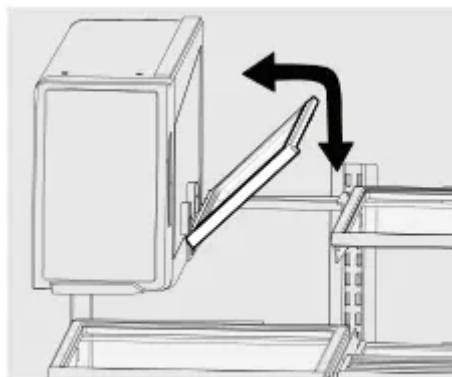

Flip Shelf

To adjust the slide-under/flip shelf:

1. Pull front half shelf forward until its back drops down, then gently push front half shelf back and under back half shelf.

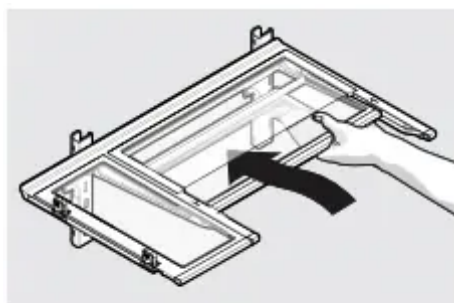

Slide-Under/Flip Shelf

2. With front half fully below back half, lift front of shelf to flip it upwards toward the back of the cabinet.

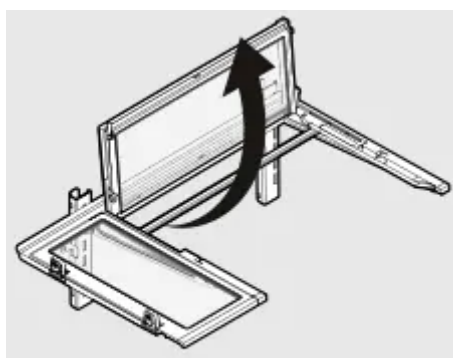

Slide-Under/Flip Shelf

Drawers

Your refrigerator includes a variety of storage drawers.

FreshSeal™ Crisper (with automatic humidity control)

Crisper drawers are designed for storing fruits, vegetables, and other fresh produce. Crispers have an auto humidity control (with replaceable membrane) on the side of each crisper under the humidity control cover.

To remove the auto humidity control membrane:

1. Reach to back of humidity control cover.
2. Pull up on cover.
3. Pull cover towards back of cabinet and remove.
4. Replace humidity membrane.
5. Replace cover by reversing the steps above. Repeat for both crispers.

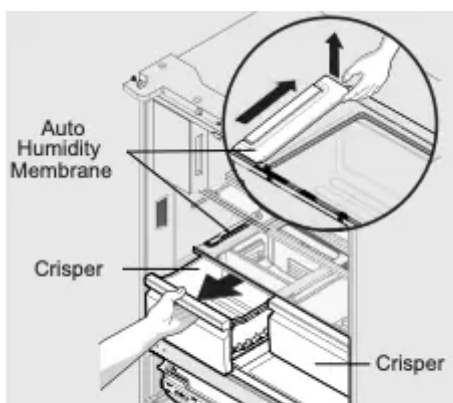

Opening the Crisper Drawer

To remove the FreshSeal™ Crisper for cleaning:

1. Pull the drawer out until it stops.
2. Lift the front slightly and remove the drawer.

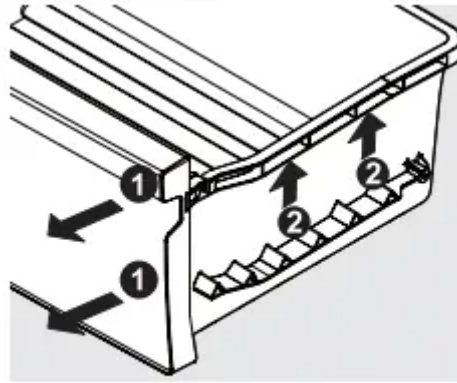

Removing the FreshSeal™ Crisper

Recessed SnackZone

This drawer is ideal for storage of deli meats and cheese. Slide back the cover to allow access to the drawers.

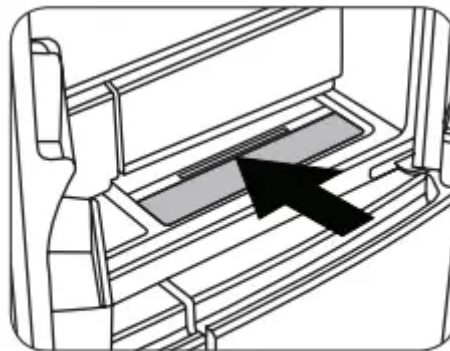

Opening the SnackZone

Doors

Storage bins

The doors to your fresh food compartment use a system of modular storage bins. All of these bins are removable for easy cleaning. Bins can be adjusted to your needs. Door bins are ideal for storing jars, bottles, cans, and large drink containers. They also enable quick selection of frequently used items.

Adjustable door bins

Some models have adjustable door bins that can be moved to suit individual needs.

To adjust the collapsible door bin:

1. Make sure bin is securely seated on rail in door.
2. Grab one side of bin and place other hand on adjustable side.
3. Pull on side of bin until the bin is adjusted to desired width.

Note: It can be difficult to pull out the collapsible bin. Some force may be required.

To move door bin along a rail:

1. Tilt bin up so the back of the bin is off the door but the hook is still engaged.
2. Slide bin along rail to desired position.
3. Lower bin back into place.

To move door bin from rail to rail:

1. Lift bin up disengaging the hook.
2. Move bin to desired rail location.
3. Push bin hook into rail engaging the hook.

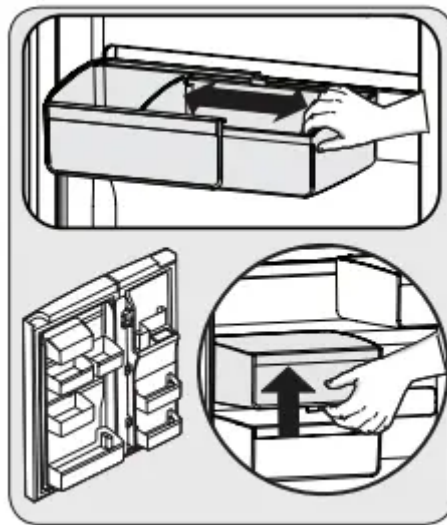

Adjustable Door Bins

Freezer Features (varies by model)

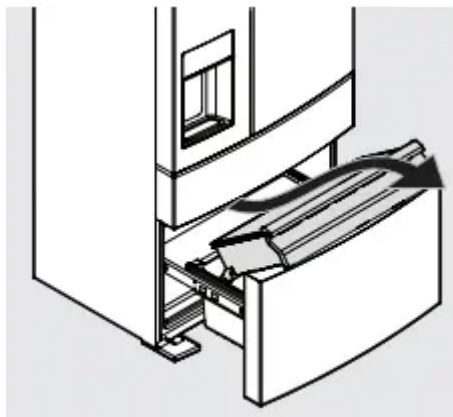

Freezer Basket

To remove upper freezer basket:

1. Open freezer compartment completely.
2. Lift up and out to remove upper freezer basket. Reverse the steps to reinstall basket.

IMPORTANT

There are wheels on the bottom of the drawer. Make sure all wheels are aligned on their respective tracks for proper function. If drawer is not aligned properly, it will cause problems with the door operation.

Note: If basket is not resting on stabilizer bar retainer clips, the drawer will not close properly

To remove lower freezer basket:

1. Open freezer compartment completely.
2. Lift the basket up and remove. Reverse the steps to reinstall drawer.

Dividers

Grab hand hold on lower divider and pull up slightly to slide to next position. (The divider cannot be removed.)

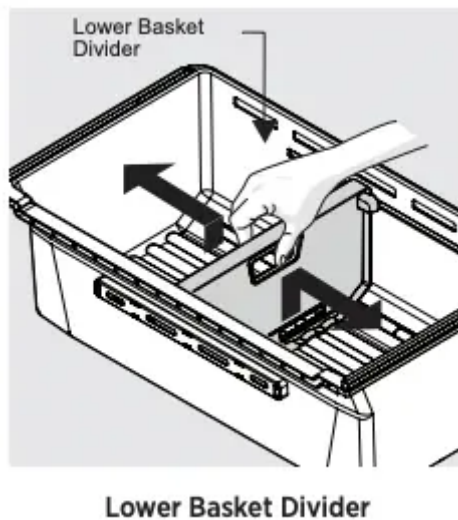

CLEANING YOUR REFRIGERATOR

WARNING BEFORE CLEANING: Turn the refrigerator off at the power point and unplug the cord to prevent any chance of electrocuting yourself.

Doors and exterior (white and silver):

You should only clean the doors with lukewarm soapy water and a soft cloth.

Stainless Steel:

Your stainless steel refrigerator is manufactured from mark-resistant stainless steel. This stainless steel has a special advanced protective coating that eases the removal of marks such as fingerprints and water spots. To keep its appearance, clean it regularly with lukewarm soapy water and a soft cloth.

CAUTION



Never use stainless steel cleaners, abrasive pads or other cleaners that will scratch the surface. Damage to the appliance after delivery is not covered by your warranty.

Interior

Clean the inside of your refrigerator regularly with a soft cloth, unscented mild soap and lukewarm water. Thoroughly dry all surfaces and removable parts and avoid getting water on the controls. Replace removable parts, plug power cord in and switch the power on before returning the food.

Door seals

Always keep door seals clean by washing them with a mild detergent and warm water, followed by a thorough drying. Sticky food and drink can cause seals to stick to the cabinet and tear when you open the door.

Never use hot water, solvents, commercial kitchen cleaners, aerosol cleaners, metal polishes, caustic or abrasive cleaners, or scourers to clean your refrigerator. Many commercially available cleaning products and detergents contain solvents that will damage your refrigerator. Use only a soft cloth with an unscented mild soap and lukewarm water

CAUTION

To clean a crisper or freezer bin with telescopic extension slides, simply wipe with a damp cloth and warm soapy water. Never immerse the cover in water, as this could affect the operation of the slide.

Switching off your refrigerator

If you switch off your refrigerator for an extended period, follow these steps to reduce the chances of mould.

1. Remove all food.
2. Remove the power plug from the power point.
3. Thoroughly clean and dry the Interior.
4. Ensure that all the doors are wedged open slightly for air circulation.

CHANGING THE FILTER

Air Filter

The air filter is located in the top center of the fresh food compartment.

Replacing your Air Filter

To ensure optimal filtering of refrigerator odors, you should change the air filter six months (The filter status light on the Touch Panel prompts you to replace the filter after six month)

1. Remove the air filter cover by squeezing the sides of the cover together and removing from liner
2. Remove the old filter and discard it.
3. Unpack the new filter and slide it into the housing. The open face must (carbon media) of the filter should be installed facing the air port (hole) in the multiflow.
4. Replace the air filter cover by squeezing the sides and snapping it back into place.
5. Press and hold the “Reset Air Filter” button on the control panel for three seconds. When the LED turns off, the status has been reset.

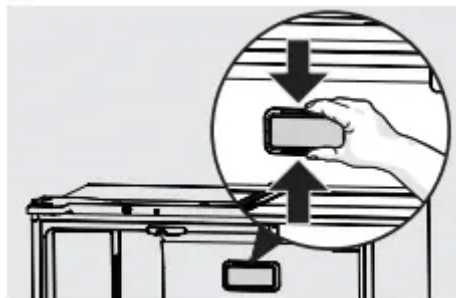

Water Filter

Your refrigerator is equipped with a water filtering system. The water filtering system filters all dispensed drinking water, as well as the water used to produce ice. The water filter is located at the top right side of the fresh food compartment.

In general, you should change the water filter every six months to ensure the highest possible water quality. Water filter status on the user interface prompts you to replace the filter after a standard amount of water (125 gallons/473 litres) has flowed through the system.

If your refrigerator has not been used for a period of time (during moving for example), change the filter before reinstalling the refrigerator

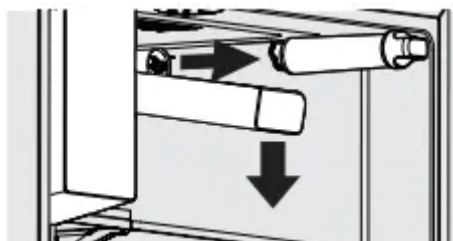

Note: When ordering your replacement filter, please reorder the same filter type that is currently in your refrigerator.

WARNING Use the appliance with water filter supplied by Electrolux Home Products Pty Ltd or its authorised service agent only.

For correct operation of this appliance it is essential to observe the manufacturer's instructions.

Replacing the Water Filter

To Remove: Pull cover towards you and cover will drop down and allow access to filter.

To Reinstall: Push cover up towards liner and then push towards rear of cabinet. Filter cover will snap back into place.

It is not necessary to turn the water supply off to change the filter. Be ready to wipe up any small amounts of water released during the filter replacement.

1. Ensure that the ice maker is turned off
2. Remove the filter by turning anti-clockwise
3. Slide the old water filter cartridge straight out of the housing and discard it.
4. Unwrap the new filter cartridge and using the alignment guide, slide it gently into filter housing until it stops against the filter connection at the back of the housing.
5. Engage the filter by firmly rotating clockwise until the filter snaps into position (once engaged the filter cannot be rotated further).
6. Press a drinking glass against the water dispenser while checking for any leaks at the filter housing. Any spurts and sputters that occur as the system purges air out of the dispenser system are normal.
7. After filling one glass of water, continue flushing the system for about four minutes.
8. Turn on the ice maker.
9. When the filter has been replaced press and hold the 'Reset Water Filter' button for three seconds to reset the filter replace timer.
10. Replace filter cover by pushing up and snapping into place.

FOOD STORAGE GUIDE

CATEGORY	PRODUCT	RECOMMENDED STORAGE TIMES FOR FRESH FOODS *			STORAGE TIPS
		REFRIGERATOR	ULTRA CHILL	FREEZER	
MEAT	Sausages and Mince	1-2 Days	3-5 Days	2-3 Months	Keep cold meat at the back of the refrigerator where it is coldest. Plastic can cause meat to sweat if stored in refrigerator for more than a day. Roast can take up to 48 hours to defrost properly, transfer frozen roast to the refrigerator 2 days before use.
	Chops and Steak	3-4 Days	5-7 Days	4-6 Months	
	Cold Meats	3-5 Days	5-7 Days	4-6 Months	
	Roasts	3-5 Days	1 week	12 Months	
POULTRY	Chicken	1-2 Days	5-7 Days	2 Months	If poultry takes on a smell or colour you are unsure about it is best to throw it out. Whole eggs are not suitable for freezing, slightly beaten eggs may be frozen for four months.
	Roast Chicken	3-5 Days	1 week	12 Months	
	Eggs	6 Weeks	Not Suitable	Not Suitable	
SEAFOOD	Whole fish and fillets	2-3 Days	5-7 Days	2 Months	Store in an airtight container or foil. Never freeze prawns in salty water as this will dehydrate the flesh.
	Lobster and Crab	1-2 Days	3-5 Days	2 Months	
	Prawns	1-2 Days	3-5 Days	2 Months	
DAIRY	Milk	Until Expiry Date	Not Suitable	Not Suitable	If dairy takes on a smell or colour and you are unsure about it, it is best to throw it out.
	Yoghurt	7- 10 Days	Not Suitable	Not Suitable	
	Hard Cheeses	2 Weeks – 2 Months	1-2 Months	2 Months (Grated)	Depending on the variety hard cheese can last from 2 weeks to 2 months.
	Soft Cheeses	1-2 Weeks	2-4 Weeks *	Not Suitable	* Texture may change depending of the type of soft cheese
	Butter	8 Weeks	3-4 Months	12 Months	
FRUIT & VEGETABLES	Every fruit and vegetable has a different shelf life. Some stay fresh for a couple of days e.g. beans, others can last for a couple of months e.g. onions.		Not Suitable	8-12 Months When freezing chop and blanch in small portions.	Keep vegetables in the crisper and away from the air vents to avoid freezing. If you wash fruit and vegetables before storing them make sure they are dry or wrap in absorbent paper before storing in the refrigerator as this can make them susceptible to rotting. Try to keep fruit and vegetables separated as fruits that give off high levels of ethylene (the ripening agent) can prematurely ripen and spoil surrounding vegetables

IMPROTANT * Please note, use this information as a guide only, actual storage times will vary depending on how you use your refrigerator.

TROUBLESHOOTING



Concern	Potential Cause	Common Solution
Automatic Ice Maker		
Ice maker is not making any ice.	<ul style="list-style-type: none"> • Ice maker is turned off. • Refrigerator is not connected to water line or water valve is not open. • The water supply line is kinked. • The water filter is not seated properly. • The water filter may be clogged with foreign material. 	<ul style="list-style-type: none"> • Turn on ice maker. For the fresh food ice maker, press ice maker on-off button once. • Connect the unit to the household water supply and ensure the water valve is open. • Ensure that the supply line does not kink when the refrigerator is pushed into place against the wall. • Remove and re-install the water filter. Be sure to seat it fully into the locked position. • If water dispenses slowly or not at all, or if the filter is six months old or older, it should be replaced.
Ice maker is not making enough ice.	<ul style="list-style-type: none"> • Ice maker is producing less ice than you expect. • The water filter may be clogged with foreign material. • The water supply line is kinked. • Water pressure is extremely low. Cut-off and cut-on pressures are too low (well systems only). • Reverse osmosis system is in regenerative phase. 	<ul style="list-style-type: none"> • The ice maker will produce approximately 1 kg of ice every 24 hours depending on usage conditions. • If water dispenses slower than normal, or if the filter is six months old or older, it should be replaced. • Ensure that the supply line does not kink when the refrigerator is pushed into place against the wall. • Have someone turn up the cut-off and cut-on pressure on the water pump system (well systems only). • It is normal for a reverse osmosis system to be below 137 kPa (20 psi) during the regenerative phase.
		<ul style="list-style-type: none"> • Remove ice container and discard ice. The ice maker will produce fresh



<p>Ice cubes are freezing together.</p>	<ul style="list-style-type: none"> • Ice cubes are not being used frequently enough or interruption of power for prolonged time. • Ice cubes are hollow (shells of ice with water inside). The hollow cubes break open in the bin and leak their water onto existing ice, which causes it to freeze together. 	<p>supply. Ice should be used at least twice weekly to keep the cubes separated.</p> <ul style="list-style-type: none"> • This generally occurs when the ice maker does not get enough water. This is usually the result of a clogged water filter or restricted water supply. Replace the water filter and if the condition still occurs, check to see if the water valve is not turned on all the way or if there is a kinked water supply line.
<p>Dispenser (Ice & Water)</p>		
<p>Dispenser (Ice & water) not dispensing ice.</p>	<ul style="list-style-type: none"> • There is no ice in the bin to be dispensed. • The refrigerator doors are not completely closed. • Dispenser paddle has been pressed too long and the dispenser motor has overheated. 	<ul style="list-style-type: none"> • See the “Ice maker is not making any ice” section. • Be sure the refrigerator doors are completely closed. • The motor overload protector will reset in about three minutes and then ice can be dispensed.
<p>Ice dispenser is jammed.</p>	<ul style="list-style-type: none"> • Ice has melted and frozen around auger due to infrequent use, temperature fluctuations, and/or power outages. • Ice cubes are jammed between ice maker and back of ice container. 	<ul style="list-style-type: none"> • Remove ice container, thaw, and empty the contents. Clean container, wipe dry, and replace in proper position. When new ice is made, dispenser should operate. • Remove ice cubes that are jamming the dispenser.
<p>Dispenser (Ice & Water)</p>		
<p>Dispenser (Ice & water) not dispensing water.</p>	<ul style="list-style-type: none"> • Dispenser (Ice & water) not dispensing water. 	<ul style="list-style-type: none"> • Remove and reinstall the water filter. Be sure to rotate it to the right until it stops and the grip end is vertical. • Replace filter cartridge. Be sure to rotate it to the right until it stops and the grip end is vertical.



		<ul style="list-style-type: none"> • Open household water line valve. See CONCERN column AUTOMATIC ICE MAKER.
Water not cold enough	<ul style="list-style-type: none"> • As warmer tap water goes through the filter and enters the water supply system, the chilled water is pushed through to the dispenser. Once the chilled water is used up, it will take several hours to bring the freshly replaced water to a cooler temperature. 	<ul style="list-style-type: none"> • Add ice to cup or container before dispensing water.
Water has an odd taste and/or odor.	<ul style="list-style-type: none"> • Water has not been dispensed for an extended period of time. • Unit not properly connected to cold water line. 	<ul style="list-style-type: none"> • Draw and discard 10-12 glasses of water to freshen the supply. • Connect unit to cold water line that supplies water to the kitchen faucet.
Opening/Closing Of Doors/Drawer		
Door(s) will not close.	<ul style="list-style-type: none"> • Door was closed too hard, causing other door to open slightly. • Refrigerator is not level. It rocks on the floor when moved slightly. • Refrigerator is touching a wall or cabinet. • Check gasket and cabinet interface for any obstructions. 	<ul style="list-style-type: none"> • Close both doors gently. • Ensure floor is level and solid, and can adequately support the refrigerator. Contact a carpenter to correct a sagging or sloping floor. • Ensure floor is level and solid, and can adequately support the refrigerator. Contact a carpenter to correct a sagging or sloping floor. • Clean the refrigerator door gaskets and interface with warm, soapy water to remove any grease, dirt and grime from the surface. Wipe clean with a dry cloth. Inspect the gasket to make sure it is thoroughly clean.
Drawers are difficult to move.	<ul style="list-style-type: none"> • Food is touching shelf on top of drawer. 	<ul style="list-style-type: none"> • Remove top layer of items in drawer. • Ensure drawer is properly installed on track.



	<ul style="list-style-type: none"> • Track that drawers slide on is dirty 	<ul style="list-style-type: none"> • Clean drawer, rollers, and track. • See Care & Cleaning.
Running of Refrigerator		
Compressor does not run.	<ul style="list-style-type: none"> • Refrigerator is in defrost cycle. • Plug at electrical outlet is disconnected. • House fuse blown or tripped circuit breaker. • Power outage. 	<ul style="list-style-type: none"> • This is normal for a fully automatic defrost refrigerator. The defrost cycle occurs periodically, lasting about 30 minutes. • Ensure plug is tightly pushed into outlet. • Check/replace fuse with a 15 amp time-delay fuse. Reset circuit breaker. • Check house lights. Call local electric company
Refrigerator seems to run too much or too long.	<ul style="list-style-type: none"> • Your variable speed compressor is designed to run 100% of the time except during the defrost cycle. At times it will run faster, such as after a defrost cycle. 	<ul style="list-style-type: none"> • It is normal for the compressor to run continuously except during defrost mode.
Digital Temperature Setting Display		
Digital temperature displays an error.	<ul style="list-style-type: none"> • Electronic control system has detected a performance problem. 	<ul style="list-style-type: none"> • Call your Electrolux service representative, who can interpret any messages or number codes flashing on the digital displays.
Water/Moisture/Frost Inside Refrigerator		
Moisture collects on inside of refrigerator walls.	<ul style="list-style-type: none"> • Weather is hot and humid. • Flipper mullion 	<ul style="list-style-type: none"> • The rate of frost buildup and internal sweating increases. • Adjust flipper mullion. (See “To adjust the flipper mullion” in the Installation section.)
Water collects on bottom side of drawer cover.	<ul style="list-style-type: none"> • Vegetables contain and give off moisture. 	<ul style="list-style-type: none"> • It is not unusual to have moisture on the bottom side of the cover.

Water collects in bottom of drawer	<ul style="list-style-type: none"> Washed vegetables and fruit drain while in the drawer 	<ul style="list-style-type: none"> Dry items before putting them in the drawer. Water collecting in bottom of drawer is normal
Water/Moisture/Frost Outside Refrigerator		
Moisture collects on outside of refrigerator or between doors.	<ul style="list-style-type: none"> Weather is humid. 	<ul style="list-style-type: none"> This is normal in humid weather. When humidity is lower, the moisture should disappear.
Food in Fresh Food Compartment		
Food is freezing.	<ul style="list-style-type: none"> Temperature setting is too low. Temperature sensor is covered by food (right side of fresh food area). Food is covering the air ports. 	<ul style="list-style-type: none"> Move the setting to a higher degree. Allow space for air flow to the sensor. Allow space between the air ports and the food.

Warning

This content is compiled from multiple sources and is provided for reference purposes only. It may not be complete or fully applicable to all situations. If you are unable to resolve your issue, please contact the product manufacturer or an authorized service provider for official support.

