

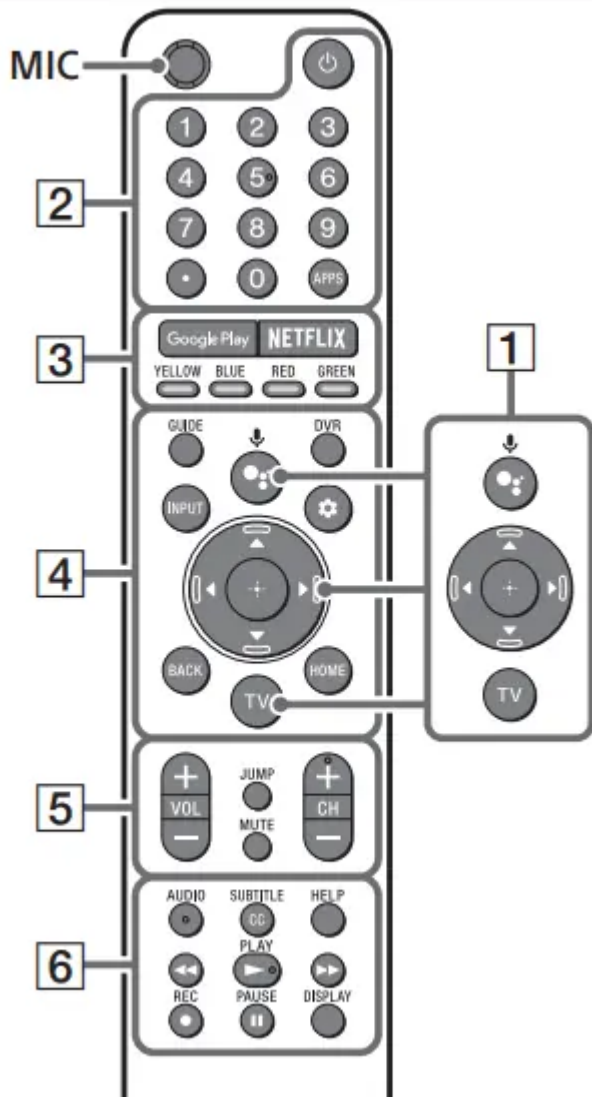









Remote Control and TV

The remote control shape, location, availability and function of remote control buttons may vary depending on your region/country/TV model.



- 1 : **(The Google Assistant)** / 
(Microphone): Use the Google Assistant*¹*² or voice search*². For hints on how to control your TV press : (the Google Assistant) /  (Microphone) button and speak the phrase "voice hints".*¹

////: On screen menu navigation and selection.

TV: Display TV channel list or switch to input.

- 2  **(TV standby)**
Number buttons

 **(dot)**

APPS: Display a list of installed apps.

- 3 **Google Play** / **NETFLIX***¹ / **Color buttons**

- 4 **GUIDE:** Display the digital program guide of TV or Cable/Satellite box*¹*³.

DVR: Display the Rec list of DVR*³.

INPUT: Display and select the input source, etc.

⚙️ (Quick settings): Display Quick Settings.

BACK

HOME

5 VOL +/- (Volume)

JUMP

MUTE*4

CH +/- (Channel)

6 AUDIO: Select the sound of multilingual source or dual sound (depend on program source).

SUBTITLE/CC

HELP: Display the Help menu.

◀️/▶️/⏮️/⏭️

● REC: Record the currently viewed program on DVR*3.

DISPLAY: Display information.

Guidelines for IR Remote Control

- Point your remote control directly at the IR sensor located on your TV.
- Make sure that no objects are blocking the path between the remote control and the IR sensor on your TV.
- Fluorescent lamps can interfere with your remote control; try turning off the fluorescent lamps.
- If you are having problems with the remote control, reinsert or replace your batteries and make sure that they are correctly inserted.

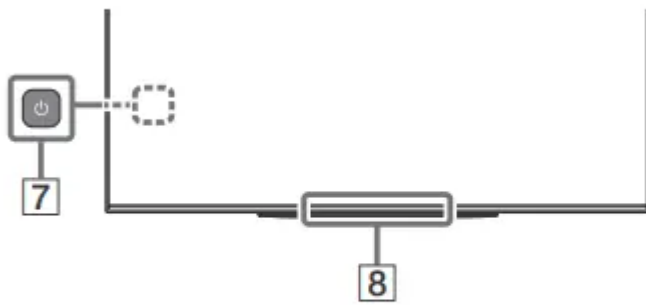

7  (Power)

8 Remote Control sensor / Light sensor / LED

**1 Only on limited region/country/TV model/ language.*

**2 The Google Assistant or voice search requires an Internet connection.*

**3 [Cable/Satellite box setup] setting is required.*

**4 Accessibility shortcut is available by pressing and holding MUTE.*

Installing the TV to the Wall

Using the optional Wall-Mount Bracket (SU-WL855 only)* (not supplied)

To Customers:

For product protection and safety reasons, Sony strongly recommends that installation of your TV be performed by Sony dealers or licensed contractors. Do not attempt to install it yourself.

To Sony Dealers and Contractors:

Provide full attention to safety during the installation, periodic maintenance and examination of this product.

Wall-Mount Bracket Installation Information

This TV's instruction manual only provides the steps to prepare the TV for Wall-Mount installation before it is installed on the wall. For instructions on Wall-Mount Bracket installation, see the Installation Information (Wall-Mount Bracket) on the Sony Customer Support website for your TV model at the following address.

Preparing for Wall-Mount Installation

You can use the Wall-Mount Bracket SU-WL855 (not supplied) to install the TV to the wall. Make sure to attach the Table-Top Stand before installing the TV to the wall by referring to the Setup Guide

- Prepare the TV for the Wall-Mount Bracket before making cable connections.
- Follow the instruction guide provided with the Wall-Mount Bracket for your model. Sufficient expertise is required in installing this TV, especially to determine the strength of the wall for withstanding the TV's weight.
- Be sure to entrust the attachment of this product to the wall to Sony dealers or licensed contractors and pay adequate attention to safety during the installation. Sony is not liable for any damage or injury caused by mishandling or improper installation.
- The length of the screw for Wall-Mount Bracket differs depending on the Wall-Mount Bracket thickness. Please refer to below illustration.

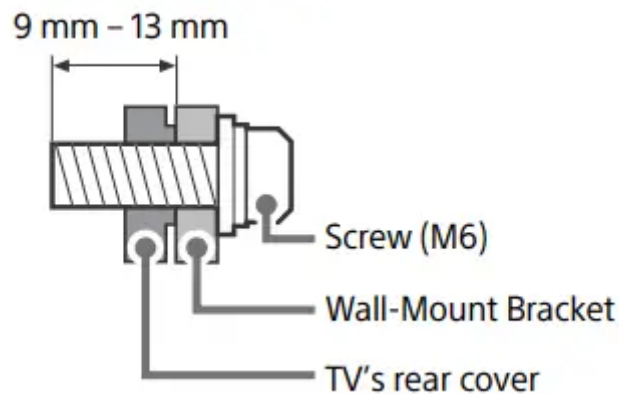

- Be sure to store the unused screws and Table-Top Stand in a safe place until you are ready to attach the Table-Top Stand. Keep the screws away from small children.

Note

- Read the supplied Safety Booklet for additional safety information.
- Only on limited region/country/TV model.

1 Remove the stand cover and terminal covers.

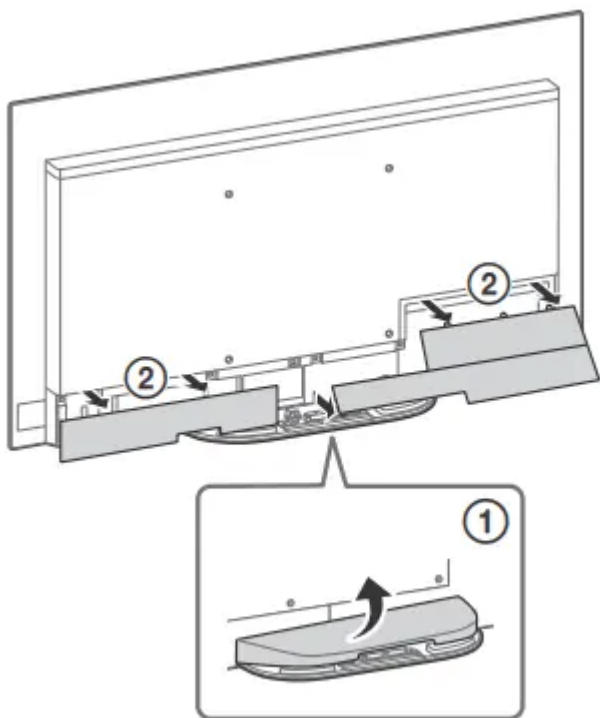

2 Remove the screws from the rear of the TV.

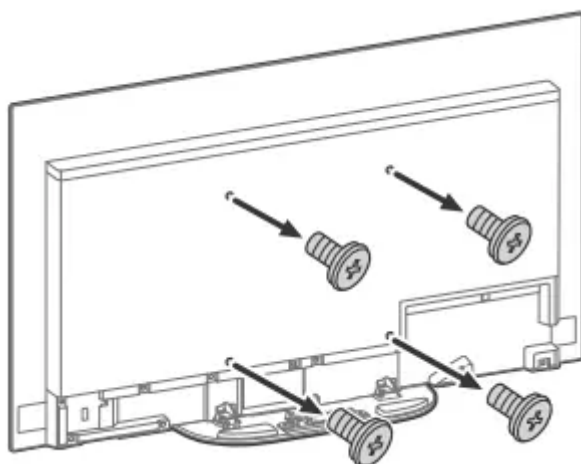

Note

- Be sure to store the removed screws and reuse when attaching the Wall-Mount Bracket to the TV set. Keep the screws away from small children.

Using the optional Wall-Mount Bracket (Except SU-WL855) (not supplied)

This TV's instruction manual only provides the steps to prepare the TV for Wall-Mount installation before it is installed on the wall.

Your TV can be mounted to a wall using a suitable Wall-Mount Bracket (not supplied). If the Table-Top Stand is attached to the TV, the TV may require detaching the Table-Top Stand; see "Detaching the Table-Top Stand from the TV".

Prepare the TV for the Wall-Mount Bracket before making cable connections

For product protection and safety reasons, Sony strongly recommends that installation of your TV on the wall be performed by qualified professionals. Do not attempt to install it yourself.

- Follow the instruction guide provided with the Wall-Mount Bracket for your model. Sufficient expertise is required in installing this TV, especially to determine the strength of the wall for withstanding the TV's weight.
- The screws for Wall-Mount Bracket are not supplied.
- The length of the screw for Wall-Mount Bracket differs depending on the Wall-Mount Bracket thickness. Please refer to below illustration.

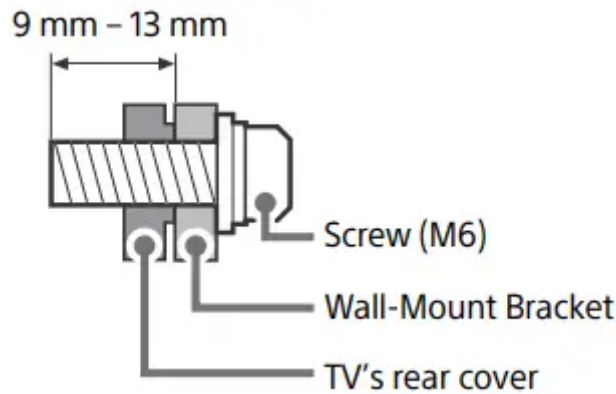

- Refer to the following table for wall-mount hole pattern.

Model Name	Wall-mount hole pattern
	a × b
XBR-48A9S	300 × 300 mm

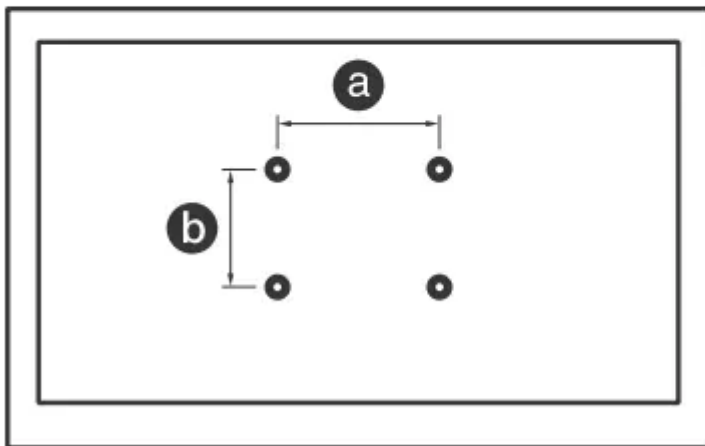

- Be sure to store the unused screws and Table-Top Stand in a safe place until you are ready to attach the Table-Top Stand. Keep the screws away from small children.

Note

- Read the supplied Safety Booklet for additional safety information.
- For more detailed information, visit Sony Customer Support website.*

* Only on limited region/country/TV model.

1 Remove the screws from the rear of the TV.

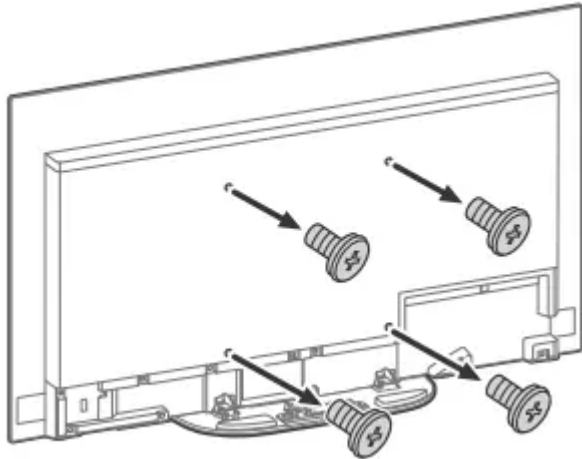

2 Attach the Wall-Mount Bracket (not supplied) using the screws (not supplied).

Wall-Mount Bracket (not supplied)

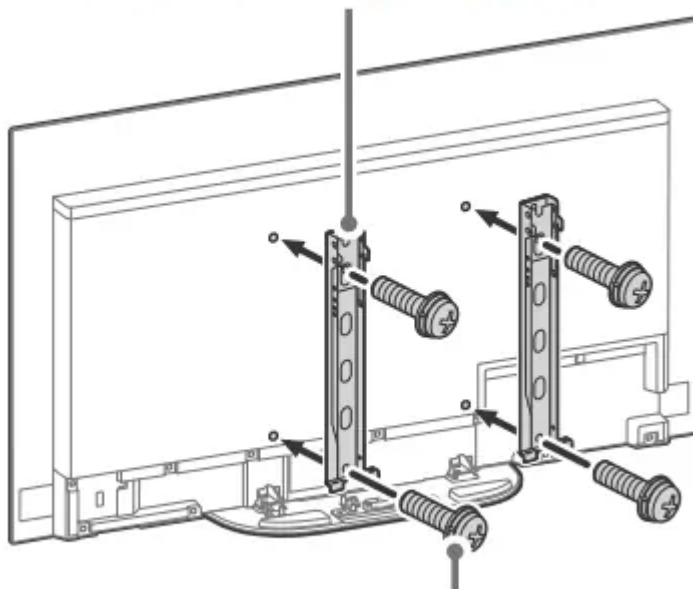

Screw (not supplied)

Note

If using an electric screwdriver, set the torque at approximately 1.5 N·m {15 kgf·cm}.

Detaching the Table-Top Stand from the TV

To detach the Table-Top Stand from the TV, remove the screws .

Note

- Do not remove the Table-Top Stand for any reason other than to install corresponding accessories on the TV.
- Be sure the TV is vertical before turning on. To avoid uneven picture uniformity do not power on the TV with the panel facing down.
- When attaching the Table-Top Stand again, be sure to fasten the screws (previously removed) to the original holes on the rear of the TV.

Troubleshooting

General troubleshooting for issues like: black screen, no sound, frozen picture, TV does not respond, or network is lost, do the following steps.

1. Restart your TV by pressing the power button on the remote control until a menu appears. Select Restart to restart the TV. If the TV does not recover, try unplugging the AC power cord. Then press the power button on the TV, and release it. Wait for two minutes, and plug in the AC power cord.
2. Refer to the Help Guide in Customer Support by pressing **HELP** on the remote control.
3. Connect your TV to the Internet and perform a software update. Sony recommends you to keep your TV software updated. Software updates provide new features and performance improvements.
4. Visit Sony support website (information provided at the end of this manual).
5. Perform the factory data reset.

When you plug in the TV, the TV may not be able to turn on for a while even if you press the power button on the remote control or the TV.

It takes time to initialize the system. Wait for about one minute, then operate it again.

How to reset the TV to factory settings

WARNING: The reset will clear all of your customized settings including the parental lock setting.

- You can reset the TV to factory settings by selecting [Reset]. How to select [Reset], refer to the Help Guide.
- To force factory data reset, unplug the AC power cord. Press and hold both and – buttons on the TV, then plug in the AC power cord. Release both buttons when the LED blinks.
- For security purposes, be sure to remove all personal and account information before discarding, selling or passing your TV to someone else by: unlinking/ unregistering, signing out of and deactivating all network services as well as factory reset the TV.

The remote control does not function.

- Replace the batteries.

The parental lock password has been forgotten.

- Enter 4357 for the PIN and enter the new PIN.

The restricted profile password has been forgotten.

- Perform the force factory data reset.

The screen becomes darker while watching TV.

- If the whole image or part of the image remains still, the screen brightness will be gradually reduced to prevent image retention. This is not a malfunction of the TV.

You are concerned about image retention.

If the same image is displayed repeatedly or for long periods of time, image retention may occur. To reduce image retention, we recommend that you turn off the TV normally by pressing the power button on the remote control or the TV.

Note

- Perform Panel refresh only when image retention is particularly noticeable. Avoid performing Panel refresh more than once a year because it may affect the usable life of the panel.
- Images that include clocks, logos and bright colors (including white) easily cause image retention. Avoid displaying these types of images for long periods of time, otherwise image retention may occur.

A white line appears on the screen.

- Panel refresh automatically runs after the TV has been used for long periods of time to reduce image retention. Panel refresh starts after the TV is turned off and takes about one hour to complete. A white line may be displayed on the screen during the Panel refresh. This is not a malfunction of the TV.

The message [Panel refresh did not finish...] is displayed.

When i) the TV is turned on, ii) the AC power cord is unplugged, or iii) the room temperature falls outside of the range between 50 °F and 104 °F (10 °C and 40 °C) during the Panel refresh, the Panel refresh is not completed. Please avoid the above three conditions during the Panel refresh

Warning

This content is compiled from multiple sources and is provided for reference purposes only. It may not be complete or fully applicable to all situations. If you are unable to resolve your issue, please contact the product manufacturer or an authorized service provider for official support.

