

## PARTS REFERENCE

### For Pools with Dual Suction Outlets Configuration:

In order to comply with the requirement of the Virginia Grahame Baker Act (for USA and Canada), your pool is designed with dual suction outlets and one inlet fittings. Overview of the dual suction outlets configuration is as follow:

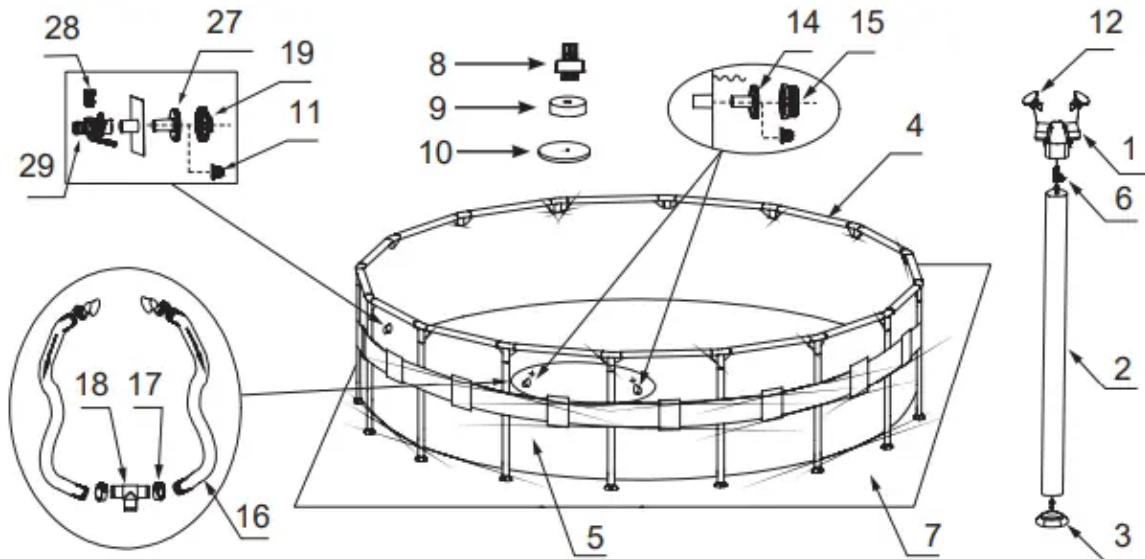

15' (457 cm) and below

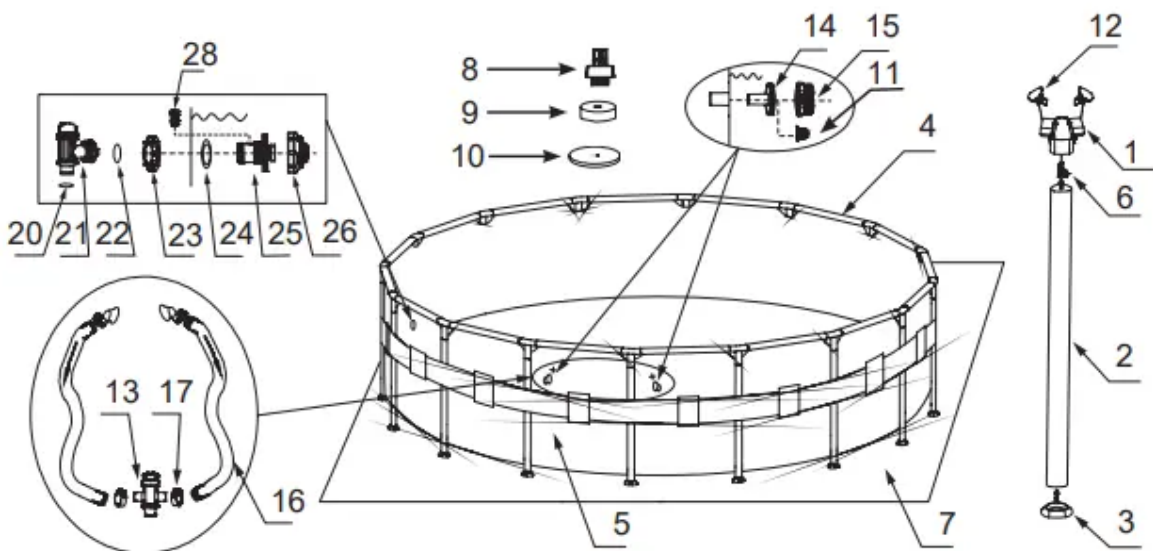

16' (488 cm) and above

**NOTE:** Drawings for illustration purpose only. Actual product may vary. Not to scale

| REF NO. | DESCRIPTION  | POOL SIZE & QUANTITIES |                |                |                |                |                |                |                |
|---------|--|------------------------|----------------|----------------|----------------|----------------|----------------|----------------|----------------|
|         |  | 14'<br>(427cm)         | 15'<br>(457cm) | 16'<br>(488cm) | 18'<br>(549cm) | 20'<br>(610cm) | 22'<br>(671cm) | 24'<br>(732cm) | 26'<br>(792cm) |
| 1       | T - JOINT  | 14                     | 15             | 16             | 18             | 20             | 22             | 24             | 26             |
| 2       | VERTICAL LEG                                       | 14                     | 15             | 16             | 18             | 20             | 22             | 24             | 26             |
| 3       | LEG CAP  | 14                     | 15             | 16             | 18             | 20             | 22             | 24             | 26             |
| 4       | HORIZONTAL BEAM                                    | 14                     | 15             | 16             | 18             | 20             | 22             | 24             | 26             |
| 5       | POOL LINER (DRAIN VALVE CAP INCLUDED)              | 1                      | 1              | 1              | 1              | 1              | 1              | 1              | 1              |
| 6       | VERTICAL LEG SPRING PIN                            | 14                     | 15             | 16             | 18             | 20             | 22             | 24             | 26             |
| 7       | GROUND CLOTH                                       | 1                      | 1              | 1              | 1              | 1              | 1              | 1              | 1              |
| 8       | DRAIN CONNECTOR                                    | 1                      | 1              | 1              | 1              | 1              | 1              | 1              | 1              |
| 9       | DRAIN VALVE CAP                                    | 1                      | 1              | 1              | 2              | 2              | 2              | 2              | 2              |
| 10      | POOL COVER   | 1                      | 1              | 1              | 1              | 1              | 1              | 1              | 1              |
| 11      | STRAINER HOLE PLUG                                 | 3                      | 3              | 2              | 2              | 2              | 2              | 2              | 2              |
| 12      | T - JOINT SPRING PIN                               | 28                     | 30             | 32             | 36             | 40             | 44             | 48             | 52             |
| 13      | SPLIT HOSE PLUNGER VALVE                           | -                      | -              | 1              | 1              | 1              | 1              | 1              | 1              |
| 14      | STRAINER CONNECTOR                                 | 2                      | 2              | 2              | 2              | 2              | 2              | 2              | 2              |
| 15      | STRAINER GRID                                      | 2                      | 2              | 2              | 2              | 2              | 2              | 2              | 2              |
| 16      | HOSE   | 2                      | 2              | 2              | 2              | 2              | 2              | 2              | 2              |
| 17      | HOSE CLAMP   | 8                      | 8              | 4              | 4              | 4              | 4              | 4              | 4              |
| 18      | HOSE T-JOINT                                       | 1                      | 1              | -              | -              | -              | -              | -              | -              |
| 19      | POOL INLET JET NOZZLE                              | 1                      | 1              | -              | -              | -              | -              | -              | -              |
| 20      | HOSE O-RING  | -                      | -              | 1              | 1              | 1              | 1              | 1              | 1              |
| 21      | PLUNGER VALVE (HOSE O-RING & STEP WASHER INCLUDED) | -                      | -              | 1              | 1              | 1              | 1              | 1              | 1              |
| 22      | STEP WASHER  | -                      | -              | 1              | 1              | 1              | 1              | 1              | 1              |
| 23      | STRAINER NUT                                       | -                      | -              | 1              | 1              | 1              | 1              | 1              | 1              |
| 24      | FLAT STRAINER RUBBER WASHER                        | -                      | -              | 1              | 1              | 1              | 1              | 1              | 1              |
| 25      | INLET THREADED AIR CONNECTOR +                     | -                      | -              | 1              | 1              | 1              | 1              | 1              | 1              |
| 26      | ADJUSTABLE POOL INLET JET NOZZLE                   | -                      | -              | 1              | 1              | 1              | 1              | 1              | 1              |
| 27      | INLET STRAINER CONNECTOR                           | 1                      | 1              | -              | -              | -              | -              | -              | -              |
| 28      | AIR JET VALVE                                      | 1                      | 1              | 1              | 1              | 1              | 1              | 1              | 1              |
| 29      | POOL INLET AIR ADAPTOR +                           | 1                      | 1              | -              | -              | -              | -              | -              | -              |
| 30      | AIR JET VALVE CAP (NOT SHOWN)                      | 1                      | 1              | 1              | 1              | 1              | 1              | 1              | 1              |

+ If applicable, depending on the size of the filter pump fitted with your pool, you must quote the model number shown on the filter pump housing to order the correct size of "Pool Inlet Air Adaptor" or "Inlet Threaded Air Connector" replacement part.



| REF NO. | DESCRIPTION  | 14' x 42" (427<br>cm x 107cm) | 14' x 48" (427<br>cm x 122cm) | 15' x 48" (457<br>cm x 122cm) | 16' x 48" (488<br>cm x 122cm) | 18' x 48" (549<br>cm x 122cm) | 18' x 52" (549<br>cm x 132cm) | 20' x 48" (610<br>cm x 122cm) | 20' x 52" (610<br>cm x 132cm) | 22' x 52" (671<br>cm x 132cm) | 24' x 52" (732<br>cm x 132cm) | 26' x 52" (792<br>cm x 132cm) |
|---------|--|-------------------------------|-------------------------------|-------------------------------|-------------------------------|-------------------------------|-------------------------------|-------------------------------|-------------------------------|-------------------------------|-------------------------------|-------------------------------|
|         |  | SPARE PART NO.                |                               |                               |                               |                               |                               |                               |                               |                               |                               |                               |
| 1       | T - JOINT  | 12423A                        | 12423A                        | 12427A                        | 12427A                        | 12427A                        | 12427A                        | 12427A                        | 12427A                        | 12427A                        | 12427A                        | 12427A                        |
| 2       | VERTICAL LEG                                       | 12425A                        | 12426A                        | 12429A                        | 12429A                        | 12429A                        | 12430A                        | 12429A                        | 12430A                        | 12430A                        | 12430A                        | 12430A                        |
| 3       | LEG CAP  | 11361                         | 11361                         | 11453                         | 11453                         | 11453                         | 11453                         | 11453                         | 11453                         | 11453                         | 11453                         | 11453                         |
| 4       | HORIZONTAL BEAM                                    | 12424A                        | 12424A                        | 12428A                        | 12428A                        | 12428A                        | 12428A                        | 12428A                        | 12428A                        | 12428A                        | 12428A                        | 12428A                        |
| 5       | POOL LINER (DRAIN VALVE CAP INCLUDED)              | 12440E                        | 12441E                        | 12442E                        | 12434E                        | 12435E                        | 12436E                        | 12443E                        | 12437E                        | 12438E                        | 12439E                        | 12495E                        |
| 6       | VERTICAL LEG SPRING PIN                            | 12432A                        | 12432A                        | 12432A                        | 12432A                        | 12432A                        | 12432A                        | 12432A                        | 12432A                        | 12432A                        | 12432A                        | 12432A                        |
| 7       | GROUND CLOTH                                       | 10080                         | 10080                         | 18932                         | 18927                         | 18933                         | 18933                         | 11290                         | 11290                         | 11510                         | 18935                         | 11543                         |
| 8       | DRAIN CONNECTOR                                    | 10184                         | 10184                         | 10184                         | 10184                         | 10184                         | 10184                         | 10184                         | 10184                         | 10184                         | 10184                         | 10184                         |
| 9       | DRAIN VALVE CAP                                    | 10649                         | 11044                         | 11044                         | 11044                         | 11044                         | 11044                         | 11044                         | 11044                         | 11044                         | 11044                         | 11044                         |
| 10      | POOL COVER   | 11054                         | 11054                         | 18901                         | 10754                         | 18937                         | 18937                         | 11289                         | 11289                         | 11509                         | 18929                         | 11542                         |
| 11      | STRAINER HOLE PLUG                                 | 10127                         | 10127                         | 10127                         | 10127                         | 10127                         | 10127                         | 10127                         | 10127                         | 10127                         | 10127                         | 10127                         |
| 12      | T - JOINT SPRING PIN                               | 12433A                        | 12433A                        | 12431A                        | 12431A                        | 12431A                        | 12431A                        | 12431A                        | 12431A                        | 12431A                        | 12431A                        | 12431A                        |
| 13      | SPLIT HOSE PLUNGER VALVE                           | -                             | -                             | -                             | 11872                         | 11872                         | 11872                         | 11872                         | 11872                         | 11872                         | 11872                         | 11872                         |
| 14      | STRAINER CONNECTOR                                 | 11070                         | 11070                         | 11070                         | 11070                         | 11070                         | 11070                         | 11070                         | 11070                         | 11070                         | 11070                         | 11070                         |
| 15      | STRAINER GRID                                      | 11072                         | 11072                         | 11072                         | 11072                         | 11072                         | 11072                         | 11072                         | 11072                         | 11072                         | 11072                         | 11072                         |
| 16      | HOSE   | 11873                         | 11873                         | 11873                         | 11873                         | 11873                         | 11873                         | 11873                         | 11873                         | 11873                         | 11873                         | 11873                         |
| 17      | HOSE CLAMP   | 11489                         | 11489                         | 11489                         | 10122                         | 10122                         | 10122                         | 10122                         | 10122                         | 10122                         | 10122                         | 10122                         |
| 18      | HOSE T-JOINT                                       | 11871                         | 11871                         | 11871                         | -                             | -                             | -                             | -                             | -                             | -                             | -                             | -                             |
| 19      | POOL INLET JET NOZZLE                              | 12364                         | 12364                         | 12364                         | -                             | -                             | -                             | -                             | -                             | -                             | -                             | -                             |
| 20      | HOSE O-RING  | -                             | -                             | -                             | 10262                         | 10262                         | 10262                         | 10262                         | 10262                         | 10262                         | 10262                         | 10262                         |
| 21      | PLUNGER VALVE (HOSE O-RING & STEP WASHER INCLUDED) | -                             | -                             | -                             | 10747                         | 10747                         | 10747                         | 10747                         | 10747                         | 10747                         | 10747                         | 10747                         |
| 22      | STEP WASHER  | -                             | -                             | -                             | 10745                         | 10745                         | 10745                         | 10745                         | 10745                         | 10745                         | 10745                         | 10745                         |
| 23      | STRAINER NUT                                       | -                             | -                             | -                             | 10256                         | 10256                         | 10256                         | 10256                         | 10256                         | 10256                         | 10256                         | 10256                         |
| 24      | FLAT STRAINER RUBBER WASHER                        | -                             | -                             | -                             | 10255                         | 10255                         | 10255                         | 10255                         | 10255                         | 10255                         | 10255                         | 10255                         |
| 25      | INLET THREADED AIR CONNECTOR +                     | -                             | -                             | -                             | 12371<br>12372                | 12371<br>12372                | 12371<br>12372                | 12371<br>12372                | 12371<br>12372                | 12371<br>12372                | 12371<br>12372                | 12371<br>12372                |
| 26      | ADJUSTABLE POOL INLET JET NOZZLE                   | -                             | -                             | -                             | 12369                         | 12369                         | 12369                         | 12369                         | 12369                         | 12369                         | 12369                         | 12369                         |
| 27      | INLET STRAINER CONNECTOR                           | 12365                         | 12365                         | 12365                         | -                             | -                             | -                             | -                             | -                             | -                             | -                             | -                             |
| 28      | AIR JET VALVE                                      | 12363                         | 12363                         | 12363                         | 12363                         | 12363                         | 12363                         | 12363                         | 12363                         | 12363                         | 12363                         | 12363                         |
| 29      | POOL INLET AIR ADAPTOR +                           | 12366<br>12367<br>12368       | 12366<br>12367<br>12368       | 12366<br>12367<br>12368       | -                             | -                             | -                             | -                             | -                             | -                             | -                             | -                             |
| 30      | AIR JET VALVE CAP (NOT SHOWN)                      | 12373                         | 12373                         | 12373                         | 12373                         | 12373                         | 12373                         | 12373                         | 12373                         | 12373                         | 12373                         | 12373                         |

+ If applicable, depending on the size of the filter pump fitted with your pool, you must quote the model number shown on the filter pump housing to order the correct size of "Pool Inlet Air Adaptor" or "Inlet Threaded Air Connector" replacement part.

**Non-USA & Canada:**



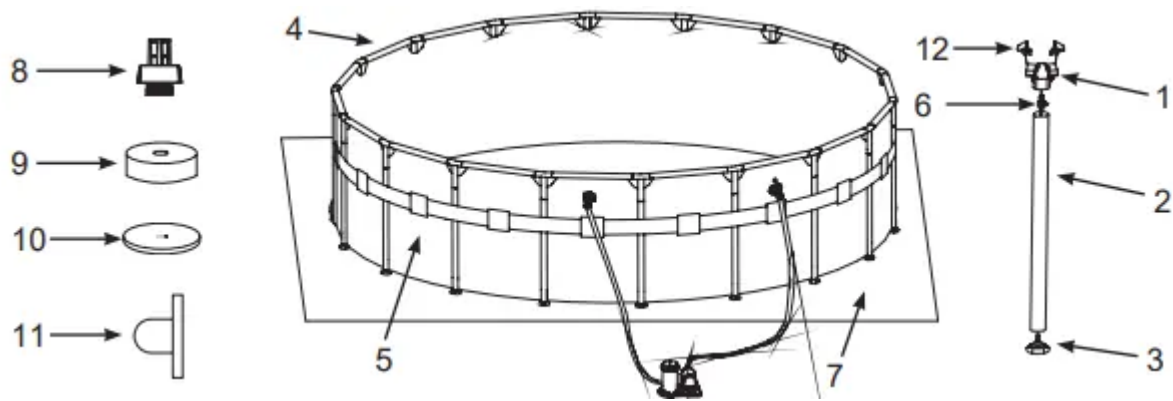

**NOTE:** Drawings for illustration purpose only. Actual product may vary. Not to scale.

**14' (427 cm), 16' (488 cm), 18' (549 cm), 20' (610 cm), 22' (671 cm), 24' (732 cm) & 26' (792 cm) models**

| REF NO. | DESCRIPTION                           | POOL SIZE & QUANTITIES |                |                |                |                |                |                |
|---------|---------------------------------------|------------------------|----------------|----------------|----------------|----------------|----------------|----------------|
|         |                                       | 14'<br>(427cm)         | 16'<br>(488cm) | 18'<br>(549cm) | 20'<br>(610cm) | 22'<br>(671cm) | 24'<br>(732cm) | 26'<br>(792cm) |
| 1       | T - JOINT                             | 14                     | 16             | 18             | 20             | 22             | 24             | 26             |
| 2       | VERTICAL LEG                          | 14                     | 16             | 18             | 20             | 22             | 24             | 26             |
| 3       | LEG CAP                               | 14                     | 16             | 18             | 20             | 22             | 24             | 26             |
| 4       | HORIZONTAL BEAM                       | 14                     | 16             | 18             | 20             | 22             | 24             | 26             |
| 5       | POOL LINER (DRAIN VALVE CAP INCLUDED) | 1                      | 1              | 1              | 1              | 1              | 1              | 1              |
| 6       | VERTICAL LEG SPRING PIN               | 14                     | 16             | 18             | 20             | 22             | 24             | 26             |
| 7       | GROUND CLOTH                          | 1                      | 1              | 1              | 1              | 1              | 1              | 1              |
| 8       | DRAIN CONNECTOR                       | 1                      | 1              | 1              | 1              | 1              | 1              | 1              |
| 9       | DRAIN VALVE CAP                       | 1                      | 1              | 2              | 2              | 2              | 2              | 2              |
| 10      | POOL COVER                            | 1                      | 1              | 1              | 1              | 1              | 1              | 1              |
| 11      | STRAINER HOLE PLUG (WITH 1 EXTRA)     | 3                      | -              | -              | -              | -              | -              | -              |
| 12      | T - JOINT SPRING PIN                  | 28                     | 32             | 36             | 40             | 44             | 48             | 52             |

| REF NO. | DESCRIPTION                           | 14' x 42" (427 cm x 107cm) | 14' x 48" (427 cm x 122cm) | 16' x 48" (488 cm x 122cm) | 18' x 48" (549 cm x 122cm) | 18' x 52" (549 cm x 132cm) | 20' x 48" (610 cm x 122cm) | 20' x 52" (610 cm x 132cm) | 22' x 52" (671 cm x 132cm) | 24' x 52" (732 cm x 132cm) | 26' x 52" (792 cm x 132cm) |
|---------|---------------------------------------|----------------------------|----------------------------|----------------------------|----------------------------|----------------------------|----------------------------|----------------------------|----------------------------|----------------------------|----------------------------|
|         |                                       | SPARE PART NO.             |                            |                            |                            |                            |                            |                            |                            |                            |                            |
| 1       | T - JOINT                             | 12423A                     | 12423A                     | 12427A                     | 12427A                     | 12427A                     | 12427A                     | 12427A                     | 12427A                     | 12427A                     | 12427A                     |
| 2       | VERTICAL LEG                          | 12425A                     | 12426A                     | 12429A                     | 12429A                     | 12430A                     | 12429A                     | 12430A                     | 12430A                     | 12430A                     | 12430A                     |
| 3       | LEG CAP                               | 11361                      | 11361                      | 11453                      | 11453                      | 11453                      | 11453                      | 11453                      | 11453                      | 11453                      | 11453                      |
| 4       | HORIZONTAL BEAM                       | 12424A                     | 12424A                     | 12428A                     | 12428A                     | 12428A                     | 12428A                     | 12428A                     | 12428A                     | 12428A                     | 12428A                     |
| 5       | POOL LINER (DRAIN VALVE CAP INCLUDED) | 12440A                     | 12441A                     | 12434A                     | 12435A                     | 12436A                     | 12443A                     | 12437A                     | 12438A                     | 12439A                     | 12495A                     |
| 6       | VERTICAL LEG SPRING PIN               | 12432A                     | 12432A                     | 12432A                     | 12432A                     | 12432A                     | 12432A                     | 12432A                     | 12432A                     | 12432A                     | 12432A                     |
| 7       | GROUND CLOTH                          | 10080                      | 10080                      | 18927                      | 18933                      | 18933                      | 11290                      | 11290                      | 11510                      | 18935                      | 11543                      |
| 8       | DRAIN CONNECTOR                       | 10184                      | 10184                      | 10184                      | 10184                      | 10184                      | 10184                      | 10184                      | 10184                      | 10184                      | 10184                      |
| 9       | DRAIN VALVE CAP                       | 10649                      | 11044                      | 11044                      | 11044                      | 11044                      | 11044                      | 11044                      | 11044                      | 11044                      | 11044                      |
| 10      | POOL COVER                            | 11054                      | 11054                      | 10754                      | 18937                      | 18937                      | 11289                      | 11289                      | 11509                      | 18929                      | 11542                      |
| 11      | STRAINER HOLE PLUG (WITH 1 EXTRA)     | 10127                      | 10127                      | -                          | -                          | -                          | -                          | -                          | -                          | -                          | -                          |
| 12      | T - JOINT SPRING PIN                  | 12433A                     | 12433A                     | 12431A                     | 12431A                     | 12431A                     | 12431A                     | 12431A                     | 12431A                     | 12431A                     | 12431A                     |

# POOL SETUP

## WARNING

- The pool location must allow you to secure all doors, windows, and safety barriers to prevent unauthorized, unintentional or unsupervised pool entry.
- Install a safety barrier that will eliminate access to the pool for young children and pets.
- Failure to set up the pool on flat, level, compact ground and to assemble and fill with water in accordance with the following instructions could result in the pool's collapse or the possibility that a person lounging in the pool could be swept out/ejected, resulting in serious injury or property damage.
- Risk of electric shock: connect the filter pump only to a grounding type receptacle protected by a ground-fault circuit interrupter (GFCI). To reduce the risk of an electrical shock, do not use extension cords, timers, plug adapters or converter plugs to connect the pump to an electrical supply. Always provide a properly located outlet. Locate the cord where it cannot be damaged by lawn mowers, hedge trimmers, and other equipment. See the filter pump manual for additional warnings and instructions.
- Risk of serious injury: do not attempt to assemble pool in high wind conditions.

## Select an outdoor location for the pool with the following requirements in mind:

1. The area where the pool is to be set up must be absolutely flat and level. Do not set up the pool on a slope or inclined surface.
2. The ground surface must be compacted and firm enough to withstand the pressure and weight of a fully set up pool. Do not set up the pool on mud, sand, soft or loose soil conditions.
3. Do not set up the pool on a deck, balcony or platform, which may collapse under the weight of the filled pool.
4. The pool requires at least 4 feet of space all around pool from objects that a child could climb on to gain access to the pool.
5. Grass under the pool will be damaged. Splash out chlorinated pool water could damage the surrounding vegetation.
6. Above ground storable pools shall be located at a minimum distance of 6 ft (1.83 meters) from any receptacle, and all 125-volt 15- and 20-ampere receptacles located within 20 ft (6.0 meters) of the pool shall be protected by a ground fault circuit interrupter (GFCI), where distances are by measuring the shortest path the supply cord of an appliance connected to the receptacle would follow without piercing a floor, wall, ceiling, doorway with hinged or sliding door, window opening, or other effective permanent barrier.
7. Eliminate all aggressive grasses first. Certain types of grass such as St. Augustine and Bermuda, may grow through the liner. Grass growing through the liner it is not a manufacture defect and is not covered under warranty.

8. The area shall facilitate drainage of the pool water after each use and/or for long term pool storage.

You may have purchased this pool with the Intex Krystal Clear™ filter pump. The pump has its own separate set of installation instructions. First assemble your pool unit and then set up the filter pump. Estimated assembly time 45-60 min. (Note the assembly time is only approximate and individual assembly experience may vary.)

### 1. Liner preparation

- Find a flat, level location that is free and clear of stones, branches or other sharp objects that may puncture the pool liner or cause injury.
- Open the carton containing the liner, joints, legs, etc., very carefully as this carton can be used to store the pool during the winter months or when not in use.
- Take out the ground cloth (7) (optional) and spread it over the cleared area. Then, take out the liner (5) and spread it out over the ground cloth, with the drain valve directed towards the draining area. Place the drain valve away from the house. Allow the sun to warm up the liner before inserting the beams (4) into the sleeve openings.

**IMPORTANT:** Always set up the pool unit with at least 2 persons. Do not drag the liner across the ground as this can cause liner damage and pool leakage (see drawing 1).

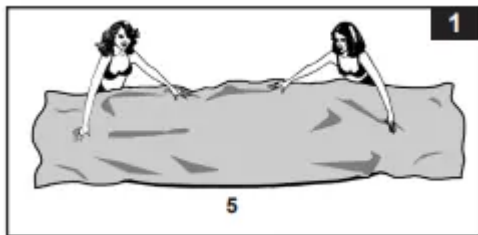

During the setup of this pool liner, point the hose connections or openings in the direction of the electric power source. The outer edge of the pool should be within reach of the pump's electrical connection.

### 2. Frame assembly

- The frame pool's legs (2) and beams (4) fall into two groups. The smaller diameters are the vertical legs. Both these legs and beams fit into the T-joints (1).

**NOTE:** Sprinkle some talcum powder over the horizontal beams before sliding them into the pool liner sleeve. This will make removal of the beams from the liner easier during the disassembly of the pool.

- Starting at any location, but always working in the same direction, push the horizontal beam into the sleeve (see drawing 2.1). Once the beam is centered take one of the T-joints (1), snap the joint to one end of the beam by aligning the hole and the spring-

loaded pin. Repeat this procedure in a circular fashion until all the beams and joints have been connected (see drawing 2.2).

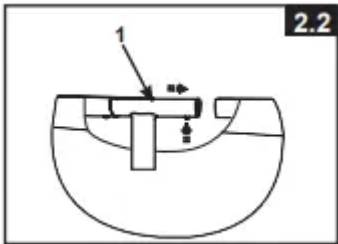
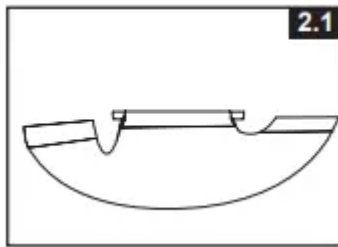

The last joint connection may be difficult to complete, but can be easily done by simultaneously raising this last joint and beam more than 2 inches (5 cm), and connect the beam to the joint while lowering these pieces to their normal position. The joint will slide into the beam (see drawing 2.3). Make sure the last joint is fully assembled before proceeding to assembling the legs.

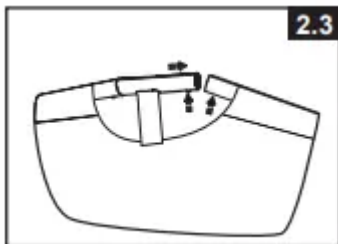

- Next slide the vertical legs into the belt loop located in the middle of the pool liner. Carefully slide the leg into the belt loop and insert the top of the leg into the bottom of the joint. Snap the leg into joint's holes by aligning the hole and the spring-loaded pin. Attach the leg's end cap (3) to the bottom of the leg (see drawing 3).

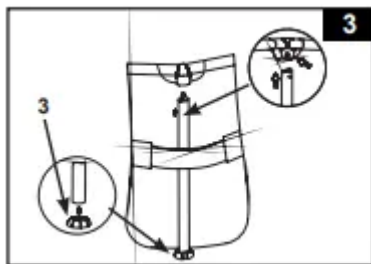

- Grab the frame pool's top beams in 2 – 3 locations and "shake" the pool to be sure all the joints, legs and beams "fit into each other".

- Pull gently, in an outward direction, the bottom of the leg making sure the leg is vertical and perpendicular to the level ground.
- If pool was purchased with a filter pump, read the Krystal Clear™ Filter Pump Manual first and then proceed to next installation step.

### 3. Filling of the pool

- Before filling the pool with water, ensure that the drain plug inside the pool is closed and that the drain cap on the outside is screwed on tightly. Fill the pool with no more than 1 inch (2.5 cm) of water. Check to see whether the water is level. **IMPORTANT:** If the water in the pool flows to one side, the pool is not completely level. Setting up the pool on unlevel ground will cause the pool to tilt resulting in the sidewall material bulging and a potential collapse of the pool. If the pool is not completely level, you must drain the pool, level the area or move the pool to a different area that is level, and re-fill the pool, following the above directions.
- Smooth out the bottom liner wrinkles (from inside the pool) by pushing out where the pool floor and pool sides meet. Or (from outside pool) reach under the side of the pool, grasp the pool floor and pull in an outward direction. If the ground cloth is causing the wrinkles, have 2 people pull from opposite sides to remove all wrinkles. Use the properly assembled pool ladder when entering or exiting the pool during this process.
- Fill the pool with water up to just below the sleeve line (see drawing 4).

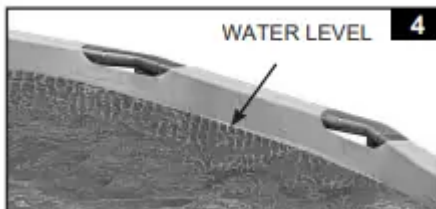

### 4. Posting aquatic safety signs

Select a highly visible area near the pool to post the Danger No Diving or Jumping sign included later in this manual.

**IMPORTANT** Before allowing anyone to use the pool, hold a family meeting. Establish a set of rules that include, at a minimum, the important safety rules and general aquatic safety information in this manual. Review these rules on a regular basis and with all users of the pool including guests. The installer of the vinyl liner shall affix on the original or replacement liner, or on the pool structure, all safety signs in accordance with the manufacturer's instructions. The safety signs shall be placed above the water line.

## POOL MAINTENANCE & CHEMICALS

### WARNING

## REMEMBER TO

- Protect all pool occupants from possible water-related illnesses by keeping the pool water clean and sanitized. Do not swallow the pool water. Always practice good hygiene.
- Keep your pool clean and clear. The pool floor must be visible at all times from the outside barrier of the pool.
- Keep children away from pool covers to avoid entanglement, drowning, or other serious injury

## Water maintenance

The maintenance of a proper water balance through appropriate use of sanitizers is the single most important factor in maximizing the life and appearance of the liner as well as ensuring clean, healthy and safe water. Proper technique is important for water testing and treating the pool water. See your pool professional for chemical, test kits and testing procedures. Be sure to read and follow the written instructions from the chemical manufacturer.

1. Never let chlorine come in contact with the liner if it is not completely dissolved. Dissolve granular or tablet chlorine first in a bucket of water, then add it to the pool water. Likewise with liquid chlorine; mix it immediately and thoroughly with the pool water.
2. Never mix chemicals together. Add the chemicals to the pool water separately. Thoroughly dissolve each chemical before adding another one to the water.
3. An Intex pool skimmer and an Intex pool vacuum are available to assist in maintaining clean pool water. See your pool dealer for these pool accessories.
4. Do not use a pressure washer to clean the pool

## POOL MAINTENANCE & DRAINAGE

**CAUTION** ALWAYS FOLLOW THE CHEMICAL MANUFACTURER'S DIRECTIONS, AND THE HEALTH AND HAZARD WARNINGS

Do not add chemicals if the pool is occupied. This can cause skin or eye irritation. Concentrated chlorine solutions can damage the pool liner. In no event is Intex Recreation Corp., Intex Development Co. Ltd., their related companies, authorized agents and service centers, retailers or employees liable to the buyer or any other party for costs associated with the loss of pool water, chemicals or water damage. Keep spare filter cartridges on hand. Replace cartridges every two weeks. We recommend the use of a Krystal Clear™ Intex Filter Pump with all of our above-ground-pools. To purchase an Intex Filter Pump or other accessories see your local retailer, visit our website or call the Intex Consumer Services Department listed in the separate "Authorized Service Centers" sheet and have your Visa or Mastercard ready.

**EXCESSIVE RAIN:** To avoid damage to the pool and over filling, immediately drain rain water that causes the water level to be higher than the maximum.

## How to Drain Your Pool and Long Term Storage

1. Check local regulations for specific directions regarding disposal of swimming pool water.
2. Check to make sure that the drain plug inside the pool is plugged in place.
3. Remove the cap from the drain valve on the outside pool wall.
4. Attach the female end of the garden hose to the drain connector (8).
5. Place the other end of the hose in an area where the water can be safely drained away from the house and other nearby structures.
6. Attach the drain connector to the drain valve. NOTE: The drain connector will push the drain plug open inside the pool and water will start to drain immediately.
7. When the water stops draining, start lifting the pool from the side opposite the drain, leading any remaining water to the drain and emptying the pool completely.
8. Disconnect hose and adapter when finished.
9. Re-insert drain plug in drain valve on inside of pool for storage.
10. Replace drain cap on outside of pool.
11. Reverse set-up instructions to disassemble the pool, and remove all connecting parts.
12. Be sure that the pool and all parts are completely dry before storage. Air dry the liner in the sun until completely dry before folding (see drawing 5). Sprinkle some talcum powder to prevent the vinyl from sticking together and to absorb any residual moisture.
13. Create a square shape. Starting at one side, fold one-sixth of liner in on itself twice. Do the same on the opposite side (see drawings 6.1 & 6.2).
14. Once you have created two opposing folded sides, simply fold one over the other like closing a book (see drawings 7.1 & 7.2).
15. Fold the two long ends to the middle (see drawing 8).
16. Fold one over the other like closing a book and finally compact the liner (see drawing 9).
17. Store the liner and accessories in a dry, temperature controlled, between 32 degrees Fahrenheit (0 degrees Celsius) and 104 degrees Fahrenheit (40 degrees Celsius), storage location.
18. The original packing can be used for storage.

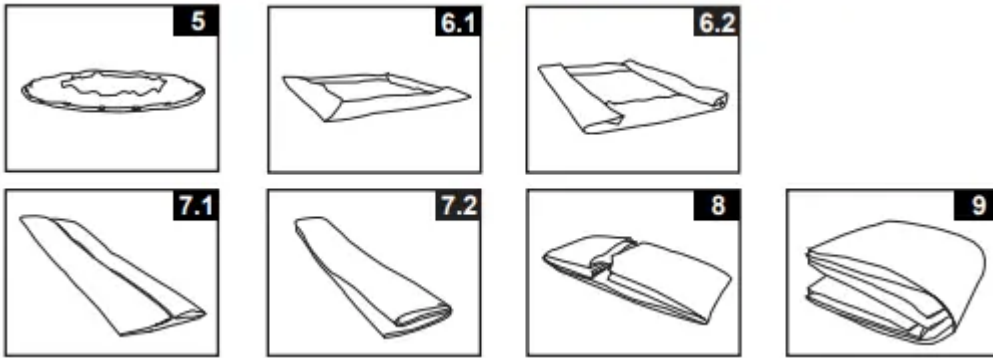

## WINTER PREPARATIONS

### Winterizing your Above Ground Pool

After usage, you can easily empty and store away your pool in a safe place. You must drain, disassemble and properly store the pool when the temperature drops below 41 degrees Fahrenheit (5 degrees Celsius) to prevent ice damage to the pool and related components. Ice damage can result in sudden liner failure or pool collapse. Also see the section "How To Drain Your Pool".

Should temperatures in your area not drop below 41 degrees Fahrenheit (5 degrees Celsius), and you choose to leave your pool out, prepare it as follows:

1. Clean the pool water thoroughly. If the type is an Easy Set Pool or an Oval Frame Pool, make sure that the top ring is properly inflated.
2. Remove the skimmer (if applicable) or any accessories attached to the threaded strainer connector. Replace strainer grid if necessary. Be sure all accessories parts are clean and completely dry before storage.
3. Plug the Inlet and Outlet fitting from the inside of the pool with the plug provided (sizes 16' and below). Close the Inlet and Outlet Plunger Valve (sizes 17' and above).
4. Remove the ladder (if applicable) and store in a safe place. Be sure the ladder is completely dry before storage.
5. Remove the hoses that connect the pump and filter to the pool.
6. Add the appropriate chemicals for the winter period. Consult your local pool dealer as to which chemicals you should use and how to use them. This can vary greatly by region.
7. Cover pool with Intex Pool Cover.

**IMPORTANT NOTE:** INTEX POOL COVER IS NOT A SAFETY COVER.

8. Clean and drain the pump, filter housing and hoses. Remove and discard the old filter cartridge. Keep a spare cartridge for the next season.
9. Bring pump and filter parts indoors and store in a safe and dry area, preferably between 32 degrees Fahrenheit (0 degrees Celsius) and 104 degrees Fahrenheit (40 degrees Celsius).

# TROUBLESHOOTING



| <b>PROBLEM</b>                  | <b>DESCRIPTION</b>  | <b>CAUSE</b>  | <b>SOLUTION</b>  |
|---------------------------------|---|---|--|
| <b>ALGAE</b>                    | <ul style="list-style-type: none"> <li>• Greenish water.</li> <li>• Green or black spots on pool liner.</li> <li>• Pool liner is slippery and/or has a bad odor.</li> </ul> | <ul style="list-style-type: none"> <li>• Chlorine and pH level need adjustment.</li> </ul>  | <ul style="list-style-type: none"> <li>• Super chlorinate with shock treatment. Correct pH to your pool store's recommended level.</li> <li>• Vacuum pool bottom.</li> <li>• Maintain proper chlorine level</li> </ul> |
| <b>COLORED WATER</b>            | <ul style="list-style-type: none"> <li>• Water turns blue, brown, or black when first treated with chlorine.</li> </ul>   | <ul style="list-style-type: none"> <li>• Copper, iron or manganese in water being oxidized by the added chlorine</li> </ul>   | <ul style="list-style-type: none"> <li>• Adjust pH to recommended level.</li> <li>• Run filter until water is clear.</li> <li>• Replace cartridge frequently.</li> </ul>   |
| <b>FLOATING MATTER IN WATER</b> | <ul style="list-style-type: none"> <li>• Water is cloudy or milky.</li> </ul>   | <ul style="list-style-type: none"> <li>• "Hard water" caused by a too high pH level.</li> <li>• Chlorine content is low.</li> <li>• Foreign matter in water.</li> </ul> | <ul style="list-style-type: none"> <li>• Correct the pH level. Check with your pool dealer for advice.</li> <li>• Check for proper chlorine level.</li> <li>• Clean or replace your filter cartridge.</li> </ul>       |
| <b>CHRONIC LOW WATER LEVEL</b>  | <ul style="list-style-type: none"> <li>• Level is lower than on previous day</li> </ul>   | <ul style="list-style-type: none"> <li>• Rip or hole in pool liner or hoses.</li> </ul>   | <ul style="list-style-type: none"> <li>• Repair with patch kit.</li> <li>• Finger tighten all caps.</li> <li>• Replace the hoses</li> </ul>  |



|                                |   |  |  |
|--------------------------------|---|--|--|
| <b>SEDIMENT ON POOL BOTTOM</b> | <ul style="list-style-type: none"> <li>• Dirt or sand on pool floor.</li> </ul> | <ul style="list-style-type: none"> <li>• Heavy use, getting in and out of pool.</li> </ul> | <ul style="list-style-type: none"> <li>• Use Intex pool vacuum to clean bottom of pool.</li> </ul> |
| <b>SURFACE DEBRIS</b>          | <ul style="list-style-type: none"> <li>• Leaves, insects etc.</li> </ul>        | <ul style="list-style-type: none"> <li>• Pool too close to trees.</li> </ul>               | <ul style="list-style-type: none"> <li>• Use Intex pool skimmer.</li> </ul>                        |

| <b>PROBLEM</b>                             | <b>CAUSE</b>   | <b>SOLUTION</b>   |
|--|--|---|
| <b>POOL INLET AIR ADAPTOR LEAKING</b>      | <ul style="list-style-type: none"> <li>• Hose clamps are not well-fitted.</li> </ul>   | <ul style="list-style-type: none"> <li>• Tighten or reinstall hose clamps.</li> </ul>   |
| <b>INLET TREADED AIR CONNECTOR LEAKING</b> | <ul style="list-style-type: none"> <li>• Plunger valve not well-fitted.</li> </ul>   | <ul style="list-style-type: none"> <li>• Tighten or reinstall hose clamps.</li> </ul>   |
| <b>AIR JET VALVE LEAKING</b>               | <ul style="list-style-type: none"> <li>• Air jet valve is not tight and facing up.</li> <li>• Air jet valve internal seal blocked.</li> <li>• Air jet valve internal seal dirty.</li> <li>• Air jet valve broken.</li> </ul> | <ul style="list-style-type: none"> <li>• Tighten air jet valve and make sure it's facing up.</li> <li>• Turn ON or plug in the pump and run for few seconds, then turn OFF or unplug, repeat 3 times.</li> <li>• Remove air jet valve, flush dirt out with water and replace valve back.</li> <li>• Replace a new air jet valve.</li> </ul> |

### **Warning**

This content is compiled from multiple sources and is provided for reference purposes only. It may not be complete or fully applicable to all situations. If you are unable to resolve your issue, please contact the product manufacturer or an authorized service provider for official support.

