

Setup

Battery Installation

1. Press and slide battery cover downward to remove.
2. Insert the batteries making sure to match the (+) (-) polarity inside the compartment.
3. Slide battery cover back into place.

Battery Precautions

- Do not mix old and new batteries.
- Do not mix alkaline, standard or rechargeable batteries.
- Always remove old, weak or worn-out batteries promptly and recycle or dispose of them in accordance with local and national regulations.

Battery Saver

Your remote automatically turn off if the buttons are held down for more than 8 seconds. This saves battery life if your remote gets stuck in a place where the buttons remain depressed.

Code Saver

You have up to 10 minutes to change the batteries in your remote without losing the codes you have programmed.

Button Functions

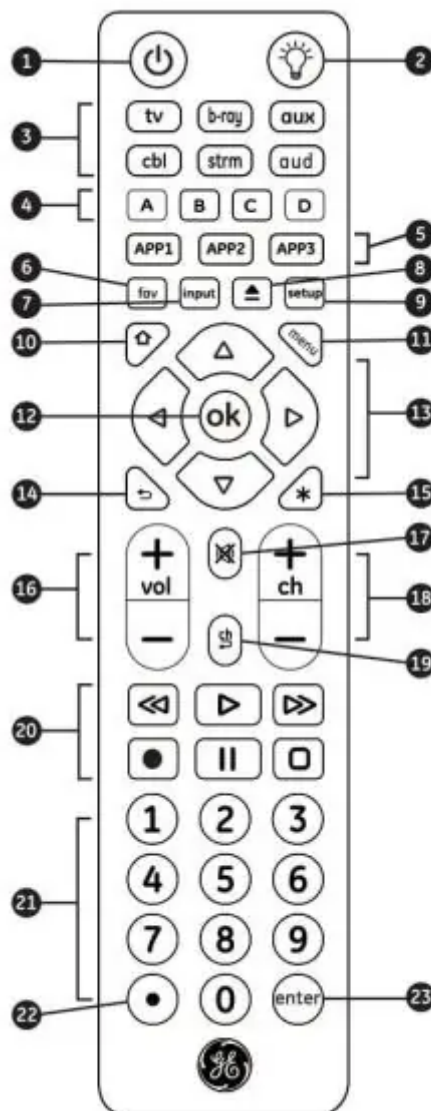

1. Power - Turns device ON/OFF
2. Blacklight - Turns LED lights ON/OFF
3. Device buttons - Select the device to control
4. ABCD - Access additional features for DVRs, cable and satellite receivers
5. APP1-3 - Access top apps like Netflix, Hulu Amazon Prime and more
6. Fav - Program up to 10 favorite channels
7. Input - Select video input
8. DVD/Blu-ray open/close - Open/close a player or List features on cable/satellite receivers
9. Setup - Used to program the remote
10. Home - Access streaming or Guide on cable and satellite receivers
11. Menu - Display on-screen menu

12. Ok - Accesses menu for selected devices
13. Up, down, left, right navigation
14. Exit - Exits the on-screen menu
15. Info - Display on-screen content information
16. Volume up/down
17. Mute - Mute sound
18. Channel up/down
19. Previous channel - Returns to previously selected channel
20. Record, play, stop, rewind, fast forward, pause
21. Numbers - For direct channel selection
22. Dot - For direct entry of digital channels
23. Enter - Same devices require ENTER to be pressed after channel selection



Direct Code Entry

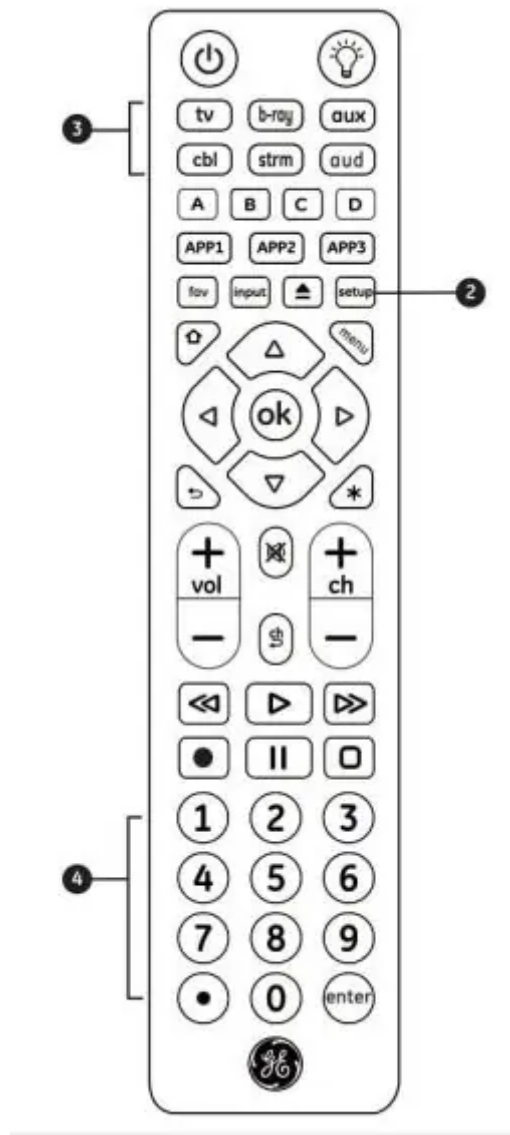

Direct code entry is recommended for quick and easy programming.

1. In the Code List, circle the 4-digit codes for the type and the brand of device you wish to control.
2. Press and hold down SETUP until the remote's red light turns on.
3. Press and release the chosen device button. The red light will blink once and remain on.
4. Enter the first 4-digit code circle in Step 1. The red light will turn off.
5. Point the remote at the device and test the buttons. If they don't work as expected, repeat Steps 2-5 with the next circled code.
6. Repeat the process for each device you wish to control.

Programming Notes

- Some codes may operate only a few device functions, so test other codes for more functionality.
- Trouble finding a code? Program the remote using the auto code search method.
- Keep your device codes for future reference.

Auto Code Search

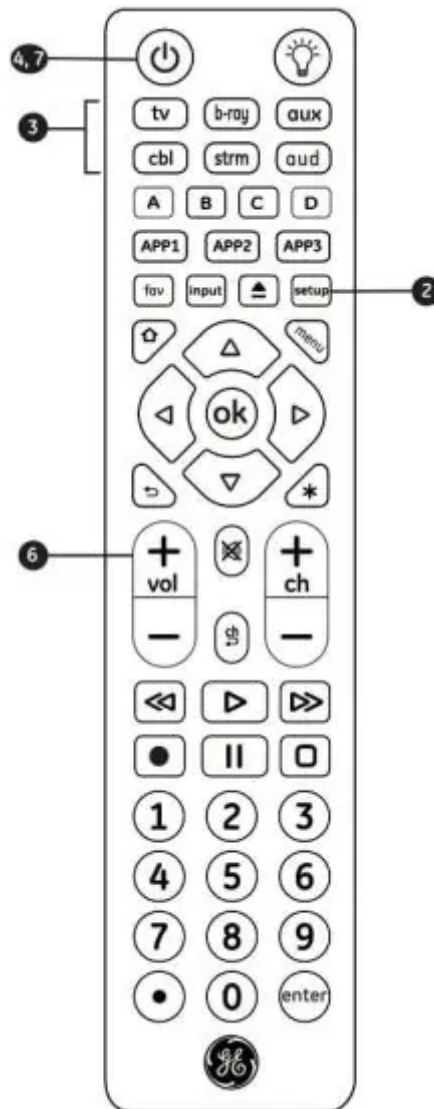

Auto code search cycles through all codes in the remote to find one for your device.

Familiarize with the Auto Code search process:

1. Manually turn on the device you wish to control
2. Press and hold down SETUP until the remote's red light turns on.
3. Press and release the chosen device button. The red light will blink once and remain on.

4. Point the remote at the device and press POWER. The red light will blink and then remain on after cycling through 10 codes.
5. Manually turn on the device
6. Point the remote at the device and press VOL+. The red light will blink once and remain on.
7. Use the remote to turn on the device. Test the remote's buttons. If they don't work as expected, repeat steps 2-7.
8. Repeat the process for each device you wish to control.

Code Identification

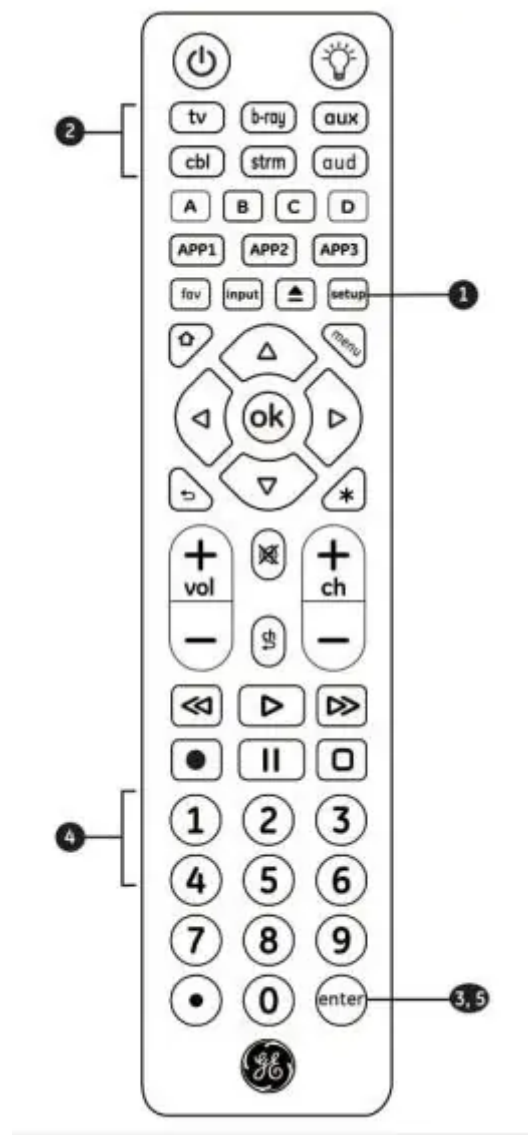

Code Identification lets you retrieve the 4-digit code used to program each of your devices buttons.

1. Press and hold down SETUP until the red light turns on.
2. Press the device button for the code you seek.

3. Press ENTER.
4. Press #1 and count how many times the red light blinks. This is the first digit in your code. Repeat the process by pressing #2 #3 #4 for the remaining digits.
5. Press ENTER to exit this mode.

Favorites

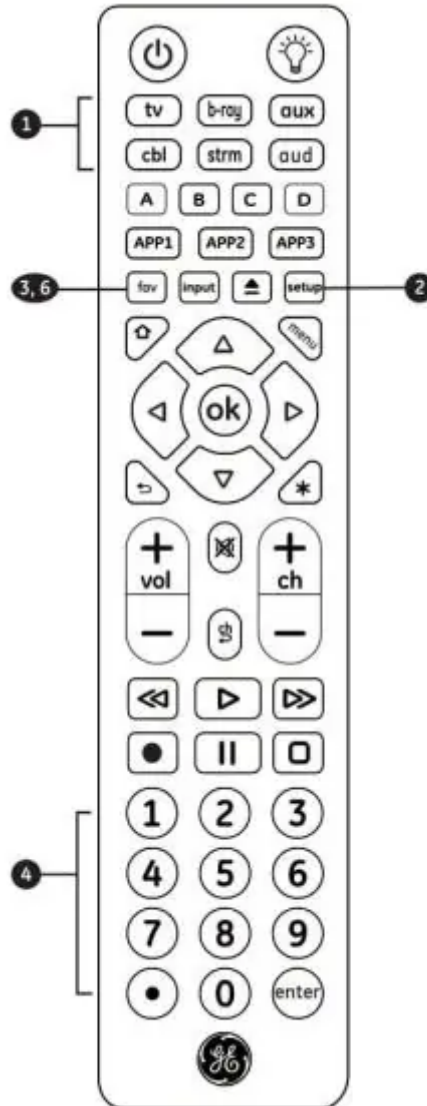

Favorites function lets you program up to 10 channels for quick access.

1. Press and release the device button for the component that controls channel selection, such as TV or cable box.
2. Press and hold down SETUP until the remote's red light turns on.
3. Press and release FAV. The red light will blink once and remain on.
4. Press and release the numerical button that you will use for storing your favorite channel. The red indicator will blink once and remain on.

5. Enter the channel number you wish to program to example channel 4, 21, 4.1, 52.2.
6. Press and release the FAV button, the red light will turn off. Your favorite channels is now saved.
7. Repeat this process for up to 10 of your favorite channels.

Using Favorites

1. Press and release FAV. The red light will turn on.
2. Press and release the programmed button for your favorite channel. The red light will blink twice and the remote will send the code for your preprogrammed channel.

Master Volume Control

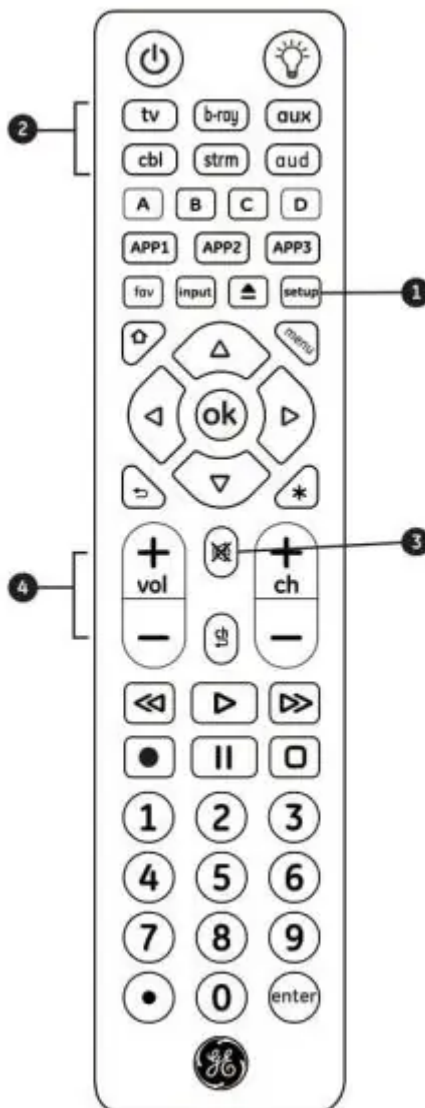

Master volume control lets you select an audio device to control the volume no matter which component you're operating.



Enabling Master Volume Control

1. Press and hold SETUP until the red light remains on.
2. Press the device button for the audio component you wish to use.
3. Press MUTE button.
4. Press VOL+. The red light will blink twice and turn off.

Disabling Master Volume Control

1. Press and hold SETUP until the red light remains on.
2. Press the device button programmed for master volume control.
3. Press MUTE button.
4. Press VOL-. The red light will blink twice and turn off.

Troubleshooting

Remote does not operate your device

- Make sure the batteries are fresh and installed correctly.
- Aim the remote directly at your device and make sure there are no obstructions between the remote and the device.
- Make sure you select the appropriate device on the remote you wish to control.
- Try programming the remote with a different code. See Direct Code Entry section.
- Remote may not be compatible with your device.

Remote does not operate some features of your device

- Sometimes a particular code might operate a few features but not all. Try programming the remote with a different code from the Code List. See Direct Code Entry section.
- Remote may not be able to operate all features of your device or button names may be different than that of your original remotes.

Reset to Factory Settings

1. Press and hold SETUP until the red light stays on.
2. Press and release the MUTE button.
3. Press and release 0. The red light will blink twice.

Warning

This content is compiled from multiple sources and is provided for reference purposes only. It may not be complete or fully applicable to all situations. If you are unable to resolve your issue, please contact the product manufacturer or an authorized service provider for official support.

Document generated by [ManualsFile](#)

