

FEATURES

External Water Dispenser Model

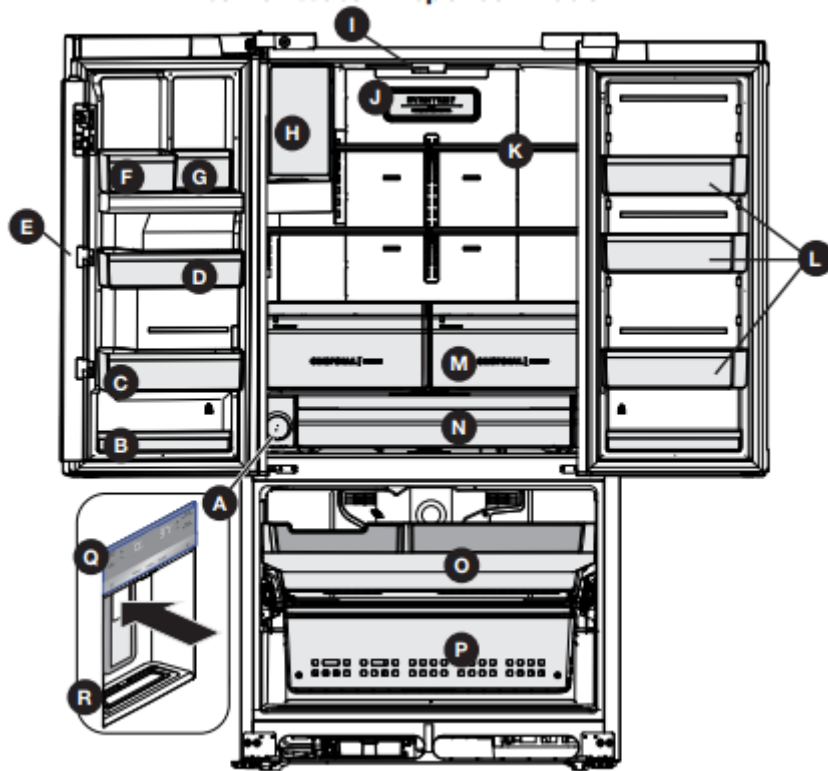

- A: Water Filter
- B: Condiment Bin
- C: L-Shaped Bin
- D: Dairy Bin
- E: Flipper Mullion
- F: Gallon Bin
- G: Slim Bin
- H: Fresh Food Ice Maker & Bin
- I: Flipper Guide
- J: Air Filter
- K: Edge-to-edge Glass Shelving
- L: Standard bin
- M: Crisper Drawers
- N: Deli Drawer

- O: Upper Freezer Baskets
- P: Lower Freezer Baskets
- Q: External Control Display
- R: Ice/Water Dispenser

IMPORTANT: Accessories are available for your appliance and may be purchased at Frigidaire.com or by calling 1-800-374-4432 (Frigidaire.ca or 1-800-265-8352 in Canada) or from an authorized seller.

Non- Dispenser Model

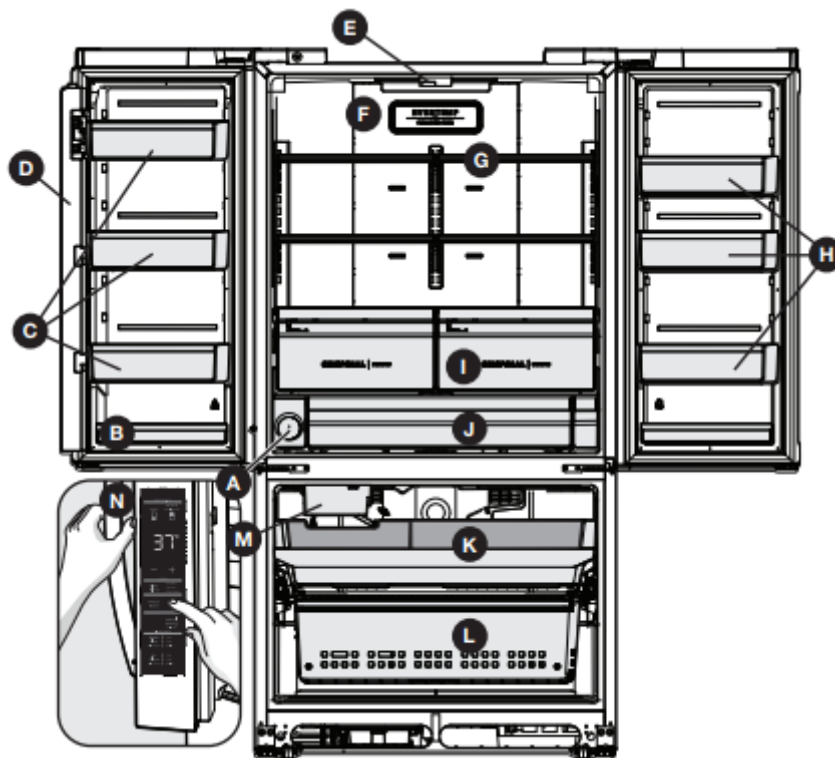

- A: Water Filter
- B: Condiment Bin
- C: Gallon Bin
- D: Flipper Mullion
- E: Flipper Guide
- F: Air Filter
- G: Edge-to-edge Glass Shelving
- H: Standard bin
- I: Crisper Drawers
- J: Deli Drawer

K: Upper Freezer Baskets

L: Lower Freezer Baskets

M: Freezer Ice maker

N: Non-Dispenser control (side door)

IMPORTANT: Accessories are available for your appliance and may be purchased at Frigidaire.com or by calling 1-800-374-4432 (Frigidaire.ca or 1-800-265-8352 in Canada) or from an authorized seller.

INSTALLATION

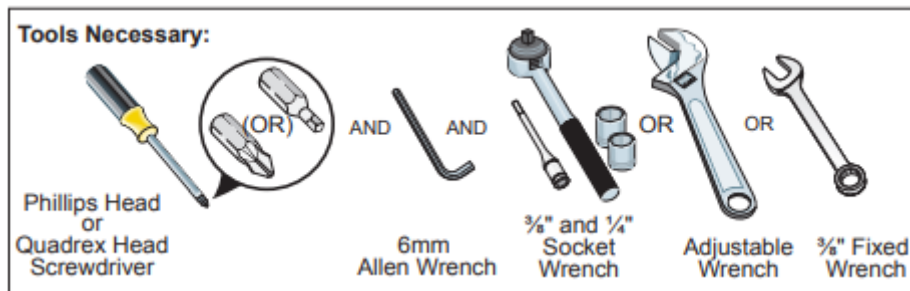

Components Provided:

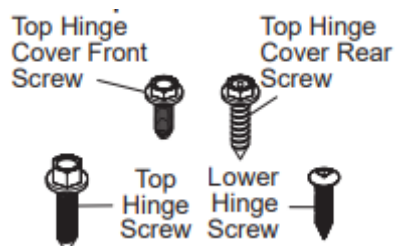

This Use & Care Manual provides general installation and operating instructions for your model. We recommend using a service or kitchen contracting professional to install your refrigerator. Use the refrigerator only as instructed in this Use & Care Manual. **Before starting the refrigerator, follow these important first steps.**

Location

- Choose a place that is near a grounded, non-GFCI, electrical outlet. **Do Not** use an extension cord or an adapter plug.
- If possible, place the refrigerator out of direct sunlight and away from the range, dishwasher, or other heat sources.
- The refrigerator must be installed on a floor that is level and strong enough to support a fully loaded refrigerator.
- Consider water supply availability for models equipped with an automatic ice maker.

WARNING: This appliance is intended to be used in household and similar applications such as:

- Staff kitchen areas in shops, offices and other working environments
- Farm houses and by clients in hotels, motels and other residential type environments
- Bed and breakfast type environments
- Catering and similar non-retail applications.

CAUTION: Do Not install the refrigerator where the temperature will drop below 55°F (13°C) or rise above 110°F (43°C). The compressor will not be able to maintain proper temperatures inside the refrigerator.

WARNING

Installation

Allow the following clearances for ease of installation, proper air circulation, and plumbing and electrical connections:

- Sides & Top $\frac{3}{8}$ inch (9.5 mm)
- Back 1 inch (25.4 mm)

NOTE: If your refrigerator is placed with the door hinge side against a wall, you may have to allow additional space so the door can be opened wider.

Door opening

Your refrigerator should be positioned to allow easy access to a counter when removing food. For best use of refrigerator drawers and freezer baskets, the refrigerator should be in a position where both can be fully opened.

Cabinet Leveling & Refrigerator Door Alignment (if necessary)

Guidelines for final positioning of refrigerator:

- All four corners of the cabinet must rest firmly on the floor.
- The front should be slightly elevated to ensure that doors close and seal properly.
- Doors should align with each other and be level.

Most of these conditions can be met by raising or lowering the adjustable anti-tip legs.

To level the cabinet using the anti-tip legs:

1. Slightly open freezer drawer to reveal anti-tip legs at bottom of cabinet.
2. Lower anti-tip legs until they are both touching the floor. Use a pair of pliers to adjust.

To raise unit: turn leg clockwise if looking from the top.

To lower unit: turn leg counterclockwise. looking from the top.

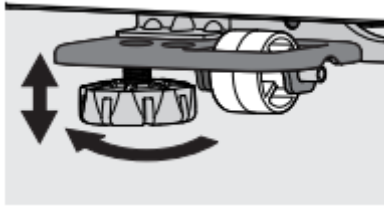

3. Ensure both doors are bind-free with their seals touching the cabinet on all four sides and that cabinet is stable.

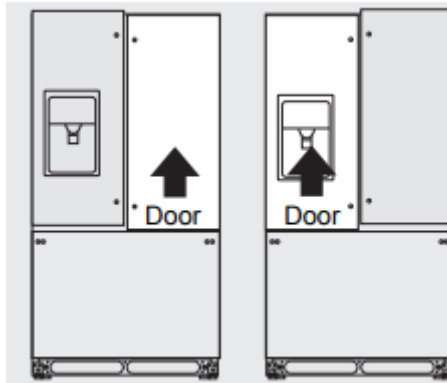

NOTE: Product is shipped with doors adjusted to the lowest position on the hinges.

To make final door height adjustments:

1. Open freezer drawer to access hinges for fresh food doors.
2. Insert 6mm Allen™ wrench into the shaft of the lower hinge. (Included with unit)

To lower door: turn adjustment screw counter-clockwise if looking at the door from below.

To raise door: turn adjustment screw clockwise if looking at the door from below.

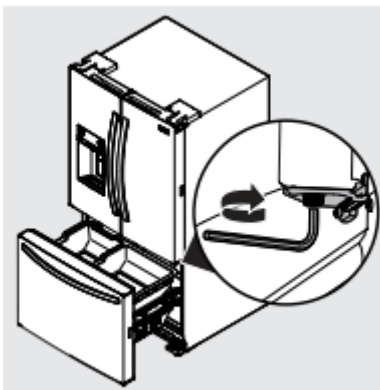

Flipper Mullion

Adjust Flipper Mullion for proper connection with the mullion guide by ensuring the flipper mullion is folded and perpendicular to the fresh food door. If the mullion guide is not in the correct position, it could prevent the door from closing completely

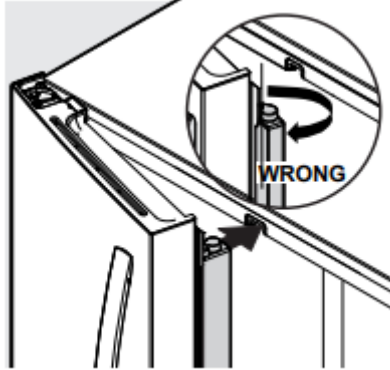

To adjust the flipper mullion:

1. Loosen the two screws located on the flipper mullion hinge.

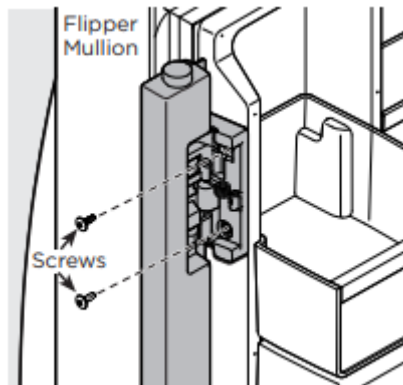

Adjusting Flipper Mullion Screw

2. Adjust flipper mullion height. For proper connection with the flipper mullion guide, there should be a separation about the thickness of a coin (0.060 inches, or 1.5 mm) between the guide and flipper mullion.

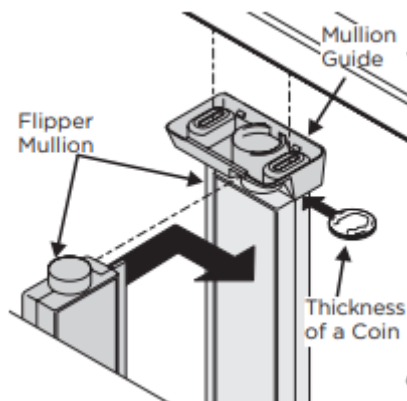

Adjusting Flipper Mullion Height

3. Re-tighten screws

DOOR REMOVAL

Getting through narrow spaces

If your refrigerator will not fit through an entrance area, you can remove the doors. Check first by measuring the entrance.

To prepare for removing the doors:

1. Make sure the electrical power cord is unplugged from the wall outlet.
2. Remove any food from the door shelves and close the doors.

WARNING: Make sure the electrical power cord is unplugged from the wall outlet.

To remove refrigerator doors:

1. Remove the three screws from both hinge covers on the left and right top of the cabinet, taking care not to damage electrical connections or sensors.

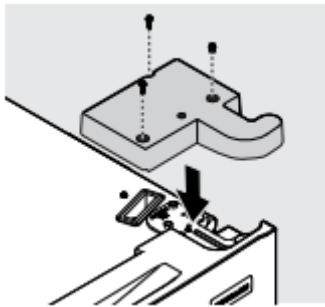

2. After the hinge covers are removed, disconnect any harnesses between the cabinet and doors by grasping both sides of the connector firmly, depress the latch and pull apart.

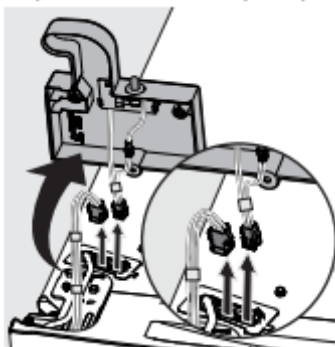

Left Door Dispenser Unit

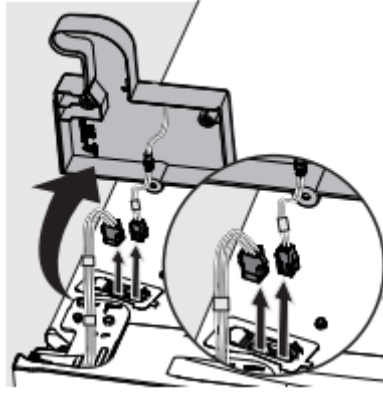

Left Door Non- Dispenser Unit

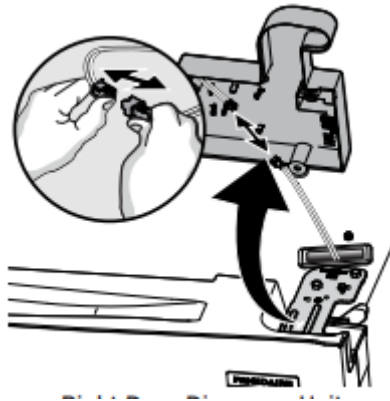

Right Door Dispenser Unit

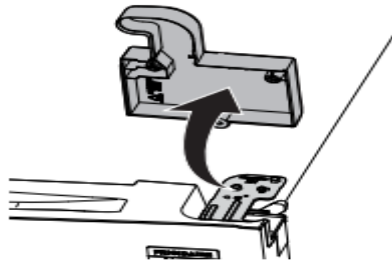

Right Door Non-Dispenser Unit

3. Trace lightly around the door's top hinges with a pencil. This makes reinstallation easier.

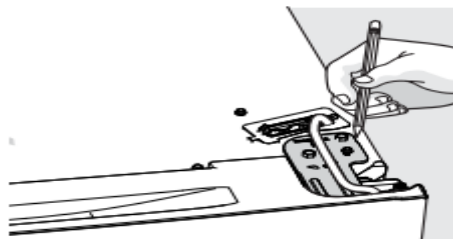

4. Remove bulkhead cover at rear of unit to access water tubing. Disconnect the water tube at the push-lock connection on the rear of the unit below the bulkhead. The dispenser line is connected to the yellow water line coming from the main water valve.

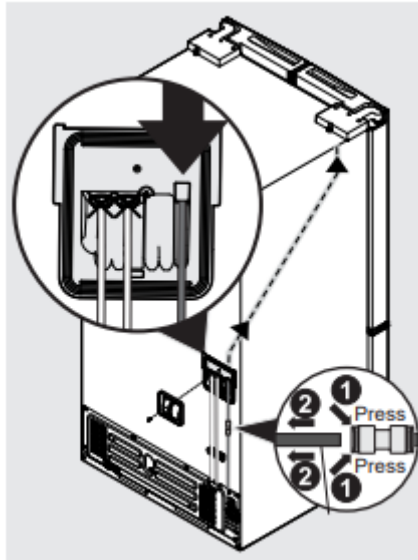

5. Pull the water tube out of the conduit from the top of the cabinet.

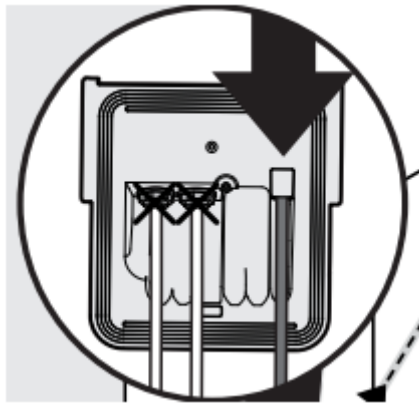

NOTE: You will be pulling approximately five feet of water tube from the back of the refrigerator. Use care while pulling the water tube from the unit to be sure that you do not kink the tube.

6. Open both doors to a 90 degree angle.

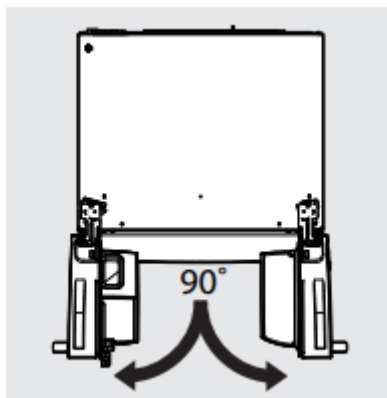

CAUTION: Be sure doors are set aside in a secure position where they cannot fall and cause personal injury, or damage to the doors or handles.

7. Remove hex screws from top hinge plate, then remove the top hinge.

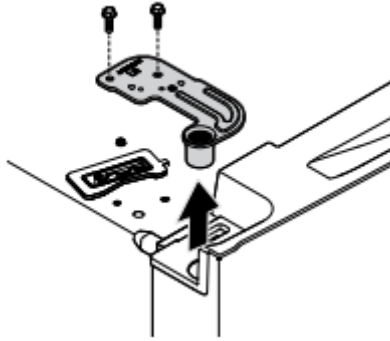

8. Lift doors off bottom hinges and set aside.

9. Unscrew the three bottom hinge screws and remove the bottom hinges.

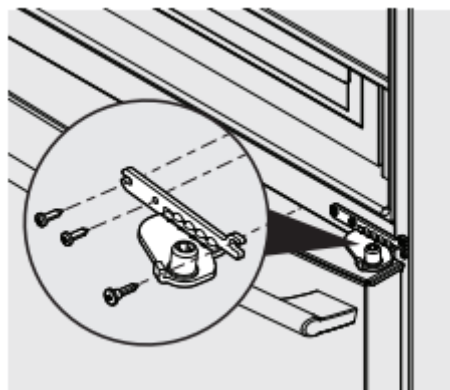

Lower Hinge Removal

To reinstall the refrigerator doors:

1. Replace three bottom hinge screws and hinges on both sides of the cabinet. Ensure screws are tightly snug to hinges on both sides of the cabinet before re-installing doors
2. Holding the door at a 90 degree angle, drop the pin down into the bottom hinge opening. Rotate it slightly in either direction until the door falls onto the hinge and is fully seated

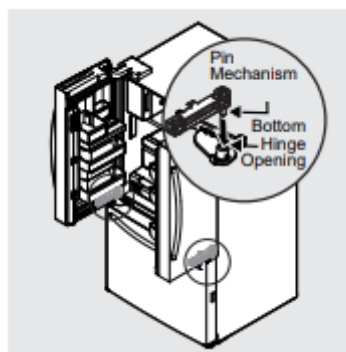

NOTE: When reinserting the water tube and replacing the top hinge cover, use care to be sure you do not kink the tube. The water line may also be difficult to pass back through the conduit inside the cabinet

NOTE: Upon replacement, the tube needs to be fully inserted up to the marking line.

3. Reinstall top hinges and screws.

4. Insert and feed water line back into the conduit at the top left door hinge until tube re-appears at rear of unit.

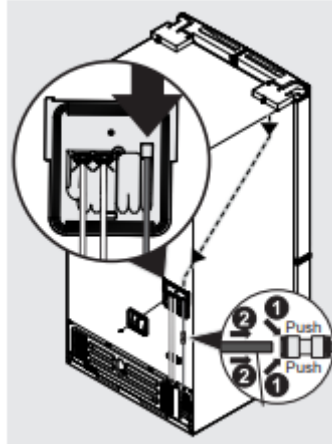

5. Reconnect all harnesses.

6. Replace top hinge covers and screws.

7. Reconnect water line to push-lock connection and reinstall water line bulkhead cover at rear of unit.

8. Reconnect electrical power cord to the wall outlet

To reset door pin:

If doors are removed at less than a 40 degree angle, the pin returns to the home position. It can be reset by turning the door upside down and using a 5/32" Allen wrench to rotate the left hand pin 90 degrees clockwise and the right hand pin 90 degrees counterclockwise.

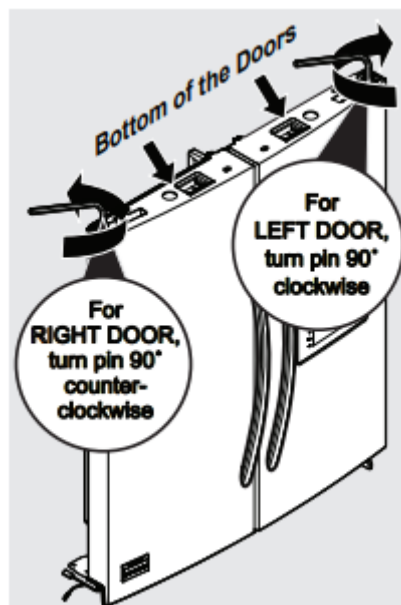

Once the door pins are reset, follow the steps “To reinstall the refrigerator doors”

Removing Freezer Drawer

CAUTION: Drawer is heavy. Use caution when lifting.

1. Remove 4 hex head drawer screws (2 per side) that secure the drawer to the slide assemblies.
2. Lift up drawer to remove.

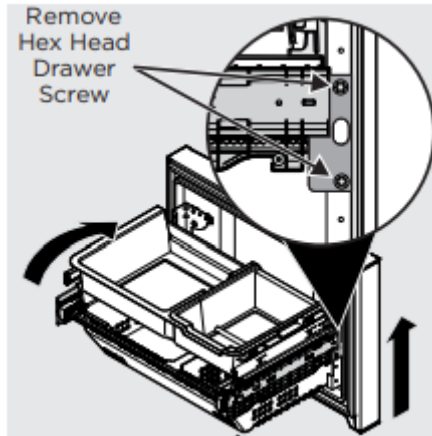

CAUTION: Do Not loosen or remove the 3 hex screws

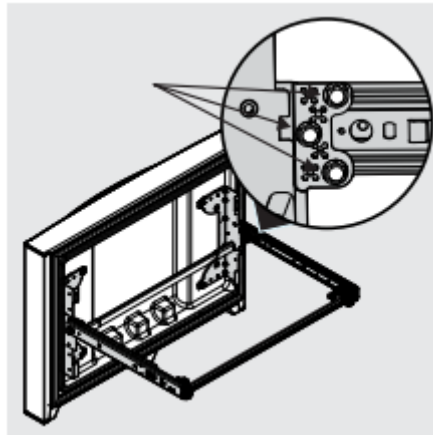

Replacing Freezer Drawer

1. Extend the Freezer slides from the unit.
2. Carefully align support pin with hooks on end of freezer slides and then lower freezer door onto slides.
3. Replace the 4 hex head screws that secure the slides to the door (2 on each side) and tighten.

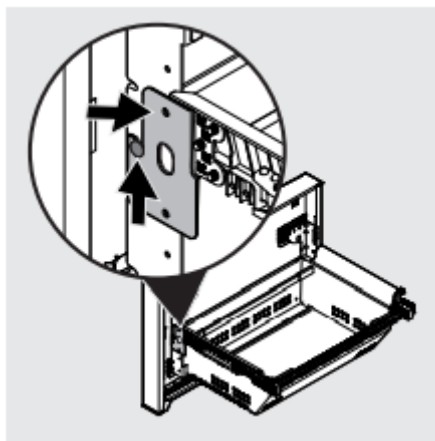

NOTE: To locate the pin, look inside the drawer and the pin is next to the door liner and the slides. Not all parts are shown in the illustration.

DOOR HANDLE INSTALLATION

CAUTION: Wear gloves and safety goggles. Use extreme CAUTION when installing these handles

Door Handle Mounting Instructions

1. Remove handles from carton and any other protective packaging.
2. Position refrigerator handle end caps over upper and lower preinstalled shoulder bolts (A) that are fastened into door, ensuring the holes for the set screws are facing towards the opposite door.
3. While holding handle firmly against door, fasten upper and lower Allen set screws (B) with supplied Allen wrench.
4. Repeat steps 2 and 3 to install opposite handle. Ensure the holes for the set screws are facing towards the opposite door.
5. Position freezer handle end caps over left and right pre-installed shoulder bolts (A) that are fastened to the door, ensuring the holes for the set screws are facing down.
6. While holding handle firmly against door, loosely tighten right Allen set screw (B) with supplied Allen wrench until there is no gap between handle and door.
7. Still holding the handle firmly to the door, firmly tighten left Allen set screw (B) with supplied Allen wrench.
8. Return to the right Allen set screw (B) and firmly tighten with supplied Allen wrench.

Mounting Refrigerator Handles

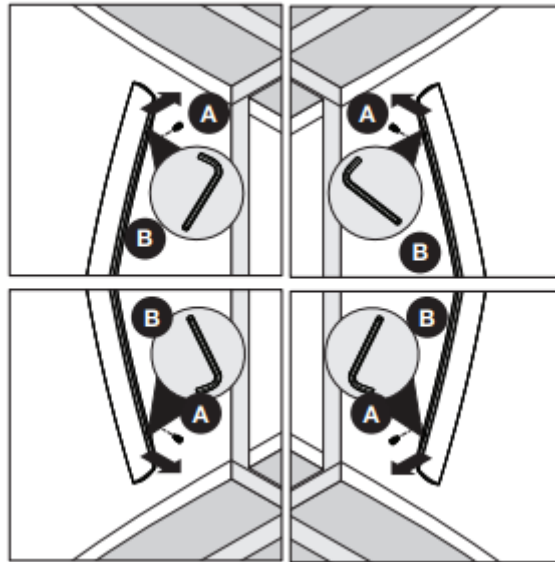

Mounting Freezer Handle

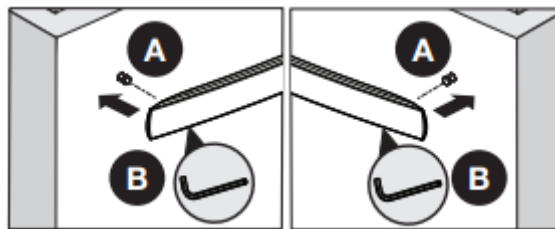

NOTE: When tightening the Allen set screws, it is important that force be applied to the longer arm of the Allen wrench supplied in the handle packaging.

NOTE:

All set screws should be tightened so the screw is below the surface of the handle. The handles should be drawn tight to freezer and refrigerator doors with no gaps. Opening the opposite door while tightening the Allen screw makes installation easier.

The door handle may loosen over time or if it was installed improperly. If this happens, tighten the set screws on the handles.

WATER SUPPLY CONNECTION

WARNING: To avoid electric shock, which can cause death or severe personal injury, disconnect the refrigerator from electrical power before connecting a water supply line to the refrigerator.

CAUTION: To Avoid Property Damage:

- Copper or Stainless Steel braided tubing is recommended for the water supply line. Water supply tubing made of ¼ inch plastic is not recommended to be used. Plastic tubing greatly increases the potential for water leaks, and the manufacturer will not be responsible for any damage if plastic tubing is used for the supply line.
- DO NOT install water supply tubing in areas where temperatures fall below freezing.

- Chemicals from a malfunctioning water softener can damage the ice maker. If your home has a water softening system, ensure the softener is maintained and working properly

IMPORTANT: Ensure that your water supply line connections comply with all local plumbing codes.

Before Installing The Water Supply Line, You Will Need:

- Basic Tools: adjustable wrench, flat-blade screwdriver, and Phillips™ screwdriver
- Access to a household cold water line with water pressure between 30 and 100 psi.
- A water supply line made of ¼ inch (6.4 mm) OD, copper or stainless steel tubing. To determine the length of tubing needed, measure the distance from the ice maker inlet valve at the back of the refrigerator to your cold water pipe. Then add approximately 6 ft. (1.8 meters) , so the refrigerator can be moved out for cleaning (as shown).
- A shutoff valve to connect the water supply line to your household water system. DO NOT use a self-piercing type shutoff valve.
- Do not re-use compression fitting or use thread seal tape.
- A compression nut and ferrule (sleeve) for connecting a copper water supply line to the ice maker inlet valve.

NOTE: Check with your local building authority for recommendations on water lines and associated materials prior to installing your new refrigerator. Depending on your local/state building codes, Frigidaire recommends for homes with existing valves its **Smart Choice®** water line kit 5305513409 with a 6 ft. (1.8 meters) Stainless Steel Water Line, and for homes without an existing valve Frigidaire recommends its **Smart Choice®** water line kit 5305510264 with a 20 ft. (6 meters) Copper Water Line with self-tapping saddle valve. Please refer to www.frigidaire.com/store for more information.

To Connect Water Supply Line To Ice Maker Inlet Valve

1. Disconnect refrigerator from electric power source.
2. Place end of water supply line into sink or bucket. Turn ON water supply and flush supply line until water is clear. Turn OFF water supply at shutoff valve.
3. Remove plastic cap from water valve inlet and discard cap.
4. If you use copper tubing - Slide brass compression nut, then ferrule (sleeve) onto water supply line. Push water supply line into water valve inlet as far as it will go (¼ inch/6.4 mm). Slide ferrule (sleeve) into valve inlet and finger tighten compression nut onto valve. Tighten another half turn with a wrench; DO NOT over tighten. See Figure 1.
 - If you use braided flexible stainless steel tubing - The nut is already assembled on the tubing. Slide nut onto valve inlet and finger tighten nut onto valve. Tighten another half turn with a wrench; DO NOT over tighten. See Figure 2.

5. With steel clamp and screw, secure water supply line to rear panel of refrigerator as shown.
6. Coil excess water supply line (copper tubing only), about 2½ turns, behind refrigerator as shown and arrange coils so they do not vibrate or wear against any other surface. Do not kink tubing.
7. Turn ON water supply at shutoff valve and tighten any connections that leak.
8. Reconnect refrigerator to electrical power source.
9. To turn ice maker on, ensure Ice Maker is enabled on display (LED will be lit) or set the ice maker's On/off power switch to the "ON" position (freezer ice maker).

NOTE: These instructions do not cover after market ice maker installation. Instructions in after market ice maker kit should be used.

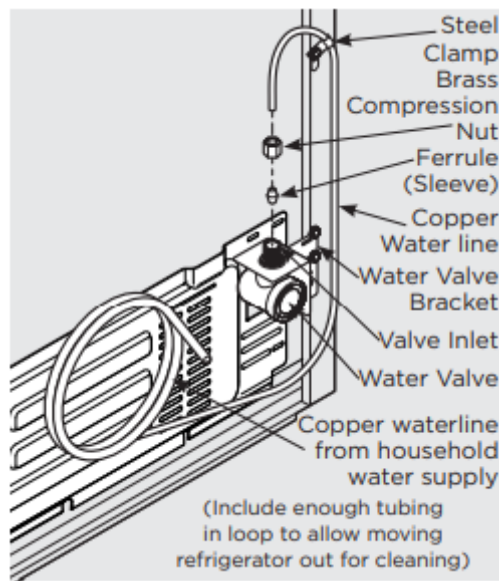

Figure 1

IMPORTANT: Your refrigerator's water supply system includes several tubing lines, a water filter, and a water valve. To ensure that your water dispenser works properly, this system must be completely filled with water when your refrigerator is first connected to the household water supply line.

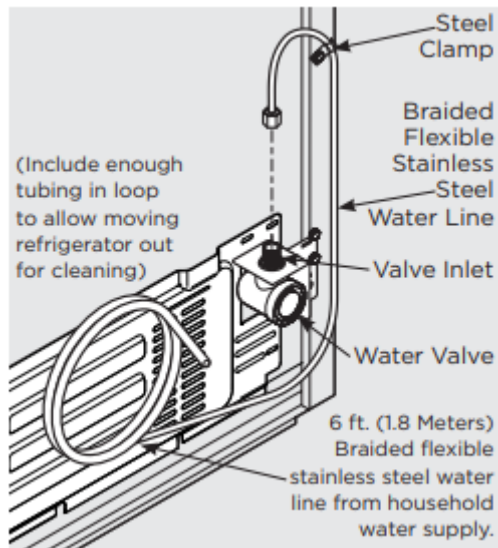
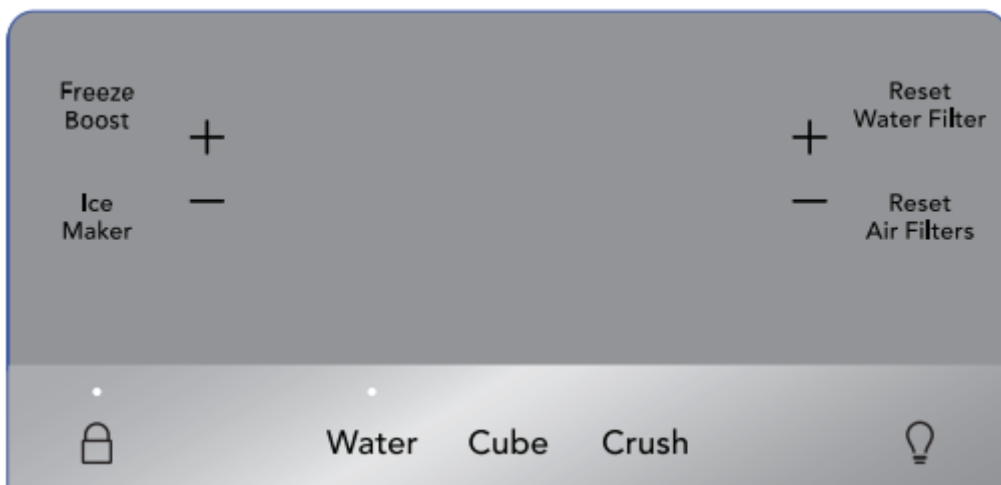

Figure 2

CONTROLS AND SETTINGS

External Water Dispenser Control Display Mode Views

Sleep Mode Display



Sleep Mode

As a default, the display will go to sleep after a short time. If any icon is pressed, the display will be awakened. After a short time, it will go back to sleep. When in sleep mode, wake up the display to confirm ice maker is On/Off. Sleep mode can be turned off to have the display on full time (awake mode). When sleep mode is Off, the display will always be illuminated. To turn sleep mode On/Off, simultaneously press and hold “Crush” and “Light” icons for 5 seconds. Tone will confirm.

Awake Mode Display

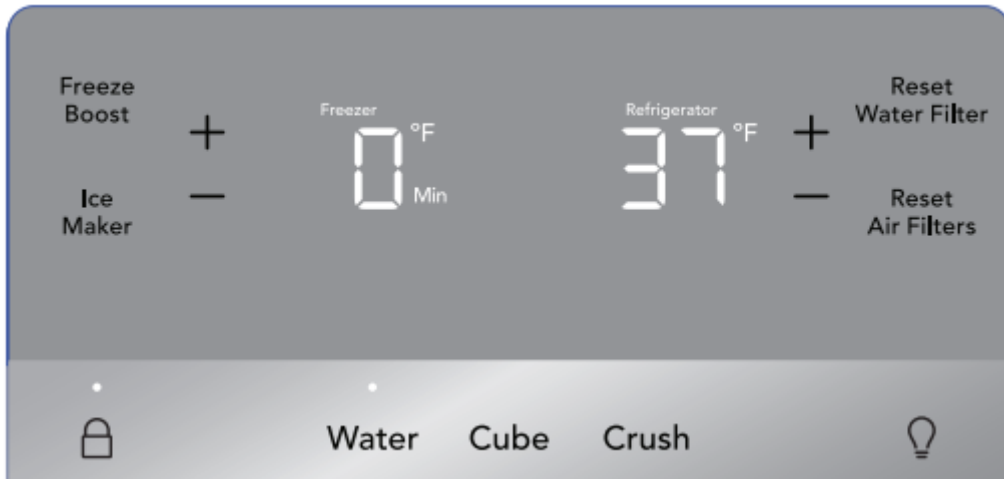

Awake Mode

To change from sleep mode (on) to awake mode (off), simultaneously press and hold “Crush” and “Light” icons for 5 seconds. Display will show the current temperature/ice maker status. Tone will confirm.

External Water Dispenser Control Display

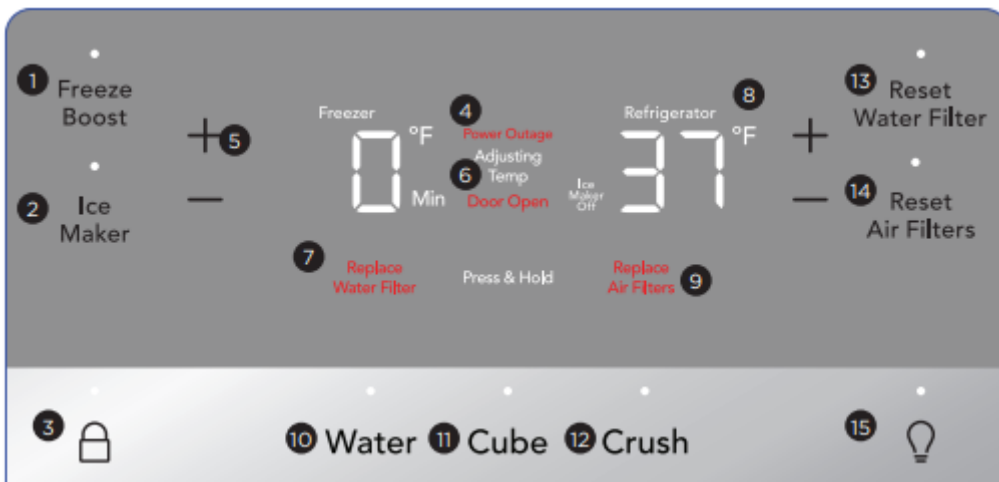

1. Freeze Boost (on/off)

Prior to grocery shopping, we recommend you activate **Freeze Boost** to lower the temperature and freeze food faster. **Freeze Boost** will remain active for up to 24 hours before automatically deactivating or manually exiting by pressing **Freeze Boost** to turn the function off. This will reset the freezer to the previous temperature setting.

2. Ice Maker

Press and hold for 3 seconds to turn ice maker on/off. When indicator is lit, ice maker is on. When indicator is not lit, ice maker is in the OFF state and will stop making ice. While off, ice

dispensing can continue as long as there is ice in the bucket. When ice maker is off and ice is dispensing, indicator will blink.

3. The lock button can be used to lock the display preventing it from being used in certain situations. Press and hold for 3 seconds to enable/ disable. While in the locked state, no changes can be made to settings on the display. Dispensing ice and water will be disabled. The indicator will flash and an audible warning tone is played

4. Power Outage

In the event of a power outage, the power outage alert will be illuminated once power has been restored and a tone will sound. Press any button to silence the tone.

5. Adjusting Temp

Illuminates when temperatures are changed on the display and will remain illuminated until the desired temperatures are reached inside the refrigerator and freezer. Press either the + or - to adjust to desired temperature setting.

Freezer temp - Control temperatures range from -6°F / -21°C to +6°F / -15°C.

Refrigerator temp - Control temperatures range from +34°F / +1°C to +44°F / +7°C. This unit is designed to operate at 37°F Refrigerator/0°F Freezer. Unit should stabilize temperatures within 24 hours of installation.

Baseline Dispenser Display

6. Door Open

This alert indicates the door has been open for 5 minutes or more. The Door Open LED illuminates and the audible alert sounds until the door is closed. The audible alert can be turned off by pressing the Door Open key or by closing the door. If the door is open for 5 minutes, the interior light will turn off.

7. Replace Water Filter

Display illuminates every 6 months or when filter needs replacing. Replace the filter then press and hold **Reset Water Filter** button for 3 seconds to deactivate the warning on display. See **Replacing the Filter** for more information.

8. F/C

To toggle between Fahrenheit (°F) and Celsius (°C), simultaneously press and hold + and - for 5 seconds on refrigerator side of display.

9. Replace Air Filters

Display illuminates every 6 months or when filter needs replacing. Replace the filter and then press and hold **Reset Air Filters** button for 3 seconds to deactivate the warning on the display. See **Replacing the Filter** for more information.

10. Water

Press the Water key to select water. An indicator light will be illuminated above the active feature.

11. Cube

Press the Cube key to select cubed ice. An indicator light will be illuminated above the active feature.

12. Crush

Press the Crush key to select crushed ice. An indicator light will be illuminated above the active feature.

13. Reset Air Filters

Filter condition status is always displayed when the door is open. Press and hold button for three seconds to reset after changing the filter.

14. Reset Water Filter

Press and hold button for three seconds to reset after filter change.

15. Light

Toggles dispenser light On and Off.

Setting cooling temperatures (options may vary)

NOTE: The recommended settings for a product installed in a kitchen is 37°F for the fresh food compartment and 0°F for the freezer.

IMPORTANT: If your product has food freezing in the fresh food compartment, increase the temperature setting 1 or 2 degrees.

IMPORTANT: If you place food within 1 inch in front of the air ports, there may be the chance of freezing food.

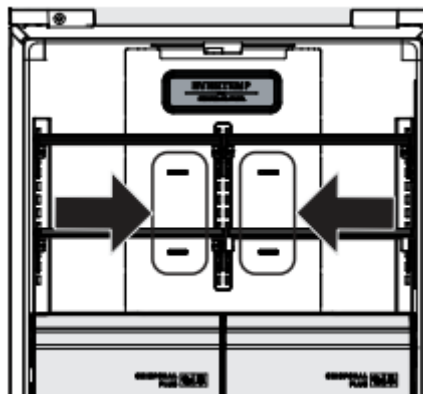

Clear Alerts

Door Open

If the freezer or refrigerator doors are left open for five minutes or more, an alarm sounds and the door open indicator illuminates on the display. Close the door or press any key on the display to silence the alarm. The control panel will return to normal operations after the door is closed.

High Temp Alarm

An alarm sounds in the event of a high temperature condition. The control panel displays HI on whichever compartment the alarm is detected in and the alarm sounds every 10 seconds until acknowledged. Touch any key or open a door to silence the alarm.

Power Outage

In the event of a power outage, a tone sounds and the power outage alert illuminates once power has been restored. Press any key on the control panel to silence the alarm.

Flapper (Dispenser Models Only)

If the flapper (or ice chute door) is held open by a jammed ice cube when “Cube” or “Crush” is selected, an alarm sounds and the current selection blinks on the dispenser control. The alarm resets when the ice cube is removed.

Sabbath Mode

The Sabbath Mode is a feature that disables portions of the refrigerator and its controls in accordance with observance of the weekly Sabbath and religious holidays within the Orthodox Jewish community.

Sabbath Mode is turned ON and OFF by simultaneously pressing and holding both the “FZ-” and “FF+” for 10 seconds. The display shows “Sb” while in Sabbath mode.

In the Sabbath Mode, the High Temp alarm is active for health reasons. For example, if the door is left ajar the High Temp alarm is activated. The refrigerator will function normally once the door is closed, without any violation of the Sabbath/Holidays. The High Temp alarm is permitted when cabinet temperature is outside the safe zone for 20 minutes. The alarm silences itself after 10 minutes while the High Temp icon stays lit until the Sabbath mode is exited.

For further assistance, guidelines for proper usage and a complete list of models with the Sabbath feature, please visit the web at <http://www.star-k.org>.

NOTE:

While in Sabbath Mode, neither the lights, dispenser, nor the control panel will work until Sabbath Mode is deactivated.

Refrigerator stays in Sabbath Mode after power failure recovery. It must be deactivated with the buttons on the control panel.

NOTE: Although you have entered the Sabbath Mode, the ice maker will complete the cycle it had already initiated. The ice cube compartment will remain cold and new ice cubes can be made with standard trays.

Non-Dispenser Control Display Mode Views

Your display is equipped with a sleep and lock mode to prevent accidental changes to the unit settings during opening and closing of the doors. When both doors are closed, the display will be in sleep mode. When either door is first opened, the display will be in lock mode where all the current settings are visible but dimmed.

Pressing any button on the display will awake the display and a tone will be played. All settings will then be fully lit. Touch the display again to change any setting.

If there is no button pressed for 10 seconds while any door is open, the display will default back to lock mode.

Awake Mode View



Lock Mode View



Sleep Mode View



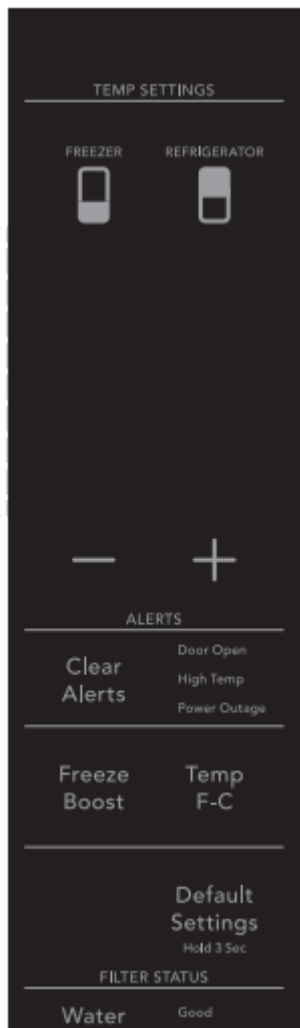

Non-Dispenser Control Display

1. Change Temperature

Select Freezer or Refrigerator compartment to change temperature.

Select +/- buttons to set the temperature

Freezer control range: -6°F/-21°C – +6°F/-15°C

Refrigerator control range: +34°F/+1°C – +44°F/+7°C

2. Clear Alerts

Resets any active lit door open, high temp or power outage alarms on the control panel.

3. Freeze Boost

Prior to grocery shopping, we recommend you activate Freeze Boost to lower the temperature and freeze food faster. Freeze Boost will remain active for up to 24 hours before automatically deactivating or manually exiting by pressing Freeze Boost to turn the function off. This will reset the freezer to the previous temperature setting.

4. F/C

Touch to toggle display from Fahrenheit to Celsius.

5. Default Settings

Press and hold for 3 seconds to reset to Factory settings.

6. Water Filter

Press and hold to reset after filter has been replaced, status shown at right of button will reset to GOOD. 7 Air Filters Press and hold to reset after filter(s) has been replaced, status shown at right of button will reset to GOOD.

NOTE: The recommended settings for a product installed in a kitchen is 37°F for the fresh food compartment and 0°F for the freezer.

Setting cooling temperatures

Press the + or – indicator to adjust the temperature to the desired setting.

The temperature setting will begin to blink with the first touch. The display will time out after 10 seconds and return to the basic display

Clear Alerts

Door Open

If the freezer or refrigerator doors have been left open for five minutes or more, an alarm will sound and the door open indicator will illuminate on the display. Press “CLEAR ALERTS” to reset any system alarms.

High Temp Alarm

HIGH TEMP will illuminate next to clear alerts button. Alarm is played every 60 seconds. Press “CLEAR ALERTS” button to acknowledge the alarm The highest temp value will be displayed when the alarm is first acknowledged.

Power Outage

In the event of a power outage, the power outage alert will be illuminated. Press “CLEAR ALERTS” to acknowledge the alarm. Other modes may be turned off until the alarm is acknowledged. While a power outage alert is displayed on the control panel, the unit will continue normal operation. The high temp alarm may also be illuminated until a safe operating range temperature has been reached.

NOTE: Food placed within 1 in. in front of air ports may cause food to freeze.

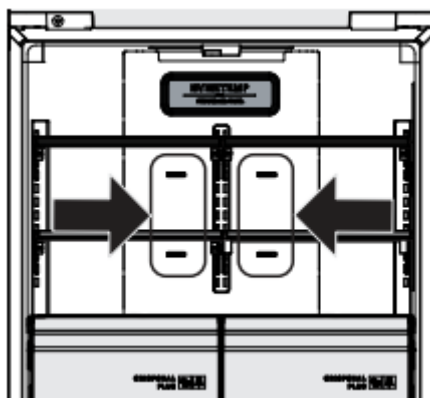

Sabbath Mode

The Sabbath Mode is a feature that disables portions of the refrigerator and its controls in accordance with observance of the weekly Sabbath and religious holidays within the Orthodox Jewish community.

Sabbath Mode is turned ON and OFF by simultaneously pressing and holding both the “-” and “Temp F-C” for five seconds. The display shows “Sb” while in Sabbath mode.

In the Sabbath Mode, the High Temp alarm is active for health reasons. For example, if the door is left ajar the High Temp alarm is activated. The refrigerator will function normally once the door is closed, without any violation of the Sabbath/Holidays. The High Temp alarm is permitted when cabinet temperature is outside the safe zone for 20 minutes. The alarm silences itself after 10 minutes while the High Temp icon stays lit until the Sabbath mode is exited.

For further assistance, guidelines for proper usage and a complete list of models with the Sabbath feature, please visit the web at <http://www.star-k.org>.

NOTE:

While in Sabbath Mode, neither the lights, dispenser, nor the control panel will work until Sabbath Mode is deactivated.

Refrigerator stays in Sabbath Mode after power failure recovery. It must be deactivated with the buttons on the control panel.

NOTE: Although you have entered the Sabbath Mode, the ice maker will complete the cycle it had already initiated. The ice cube compartment will remain cold and new ice cubes can be made with standard trays.

AUTOMATIC ICE & WATER DISPENSER

Refrigerator Ice Maker (External Dispenser Models Only)

Priming the water supply system

Using the dispenser after installation

Before making ice for the first time, be sure to prime the water supply system. Air in new plumbing lines can result in two or three empty ice maker cycles. Furthermore, if the system is not flushed, the first ice cubes may have discolored water or have an odd flavor.

CAUTION: For proper dispenser operation, recommended water supply pressure should fall between 30 psi and 100 psi. Excessive pressure may cause the system to malfunction.

1. Begin filling the system by pressing and holding a drinking glass against the water dispenser paddle.
2. Keep the glass in this position until water comes out of the dispenser. It may take about 1½ minutes.
3. Continue dispensing water for about four minutes to flush the system and plumbing connections of any impurities (stopping to empty the glass as necessary).

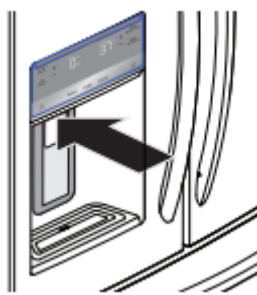

Dispenser (varies by model)

NOTE: The water dispenser has a built-in device that shuts off the water flow after three minutes of continuous use. To reset this shutoff device, simply release the dispenser paddle.

NOTE: Dispensed water is not chilled. For colder water, add ice to cup or container before dispensing water.

Ice Maker Operation & Care

After the refrigerator is installed properly and has cooled for several hours, the ice maker can produce ice within 24 hours. The ice maker will fill the ice bin from the rear. You must dispense some ice to force the ice forward in the bin. This will allow the bin to fill completely.

Ice Maker and Storage Bin Capacity

In a Standard Depth model, the refrigerator ice maker should produce 3.0 to 3.4 pounds of ice per 24 hours. In a Counter Depth model, the refrigerator ice maker should produce 2.7 to 3.2 pounds of ice per 24 hours.

In a Standard Depth model, the refrigerator ice bin will hold around 5 pounds of ice. In a Counter Depth model, the refrigerator ice bin will hold around 3.7 pounds of ice.

Turning the refrigerator ice maker on and off

Ice production is controlled by the ice maker's On/Off feature on the control panel. Pressing the On/Off feature turns the ice maker on & off.

IMPORTANT: Turning off the ice maker simply disables ice making. You will still be able to dispense existing ice, and you will still be able to dispense water.

NOTE: The ice maker also has a built-in plastic signal arm that automatically stops ice production when the ice bin is full. This signal arm should not be used to manually stop the ice maker.

IMPORTANT: Your ice maker is turned on at the factory so it can work as soon as you install your refrigerator. If you cannot connect a water supply, set the ice maker's On/Off feature to Off; otherwise, the ice maker's fill valve may make a loud chattering noise when it attempts to operate without water.

IMPORTANT: On occasion, unusually small ice cubes may be noticed in the bucket or in dispensed ice. This could occur in normal operation of the ice maker. If you start seeing these more frequently, it may be an indication of low water pressure or the water filter needs to be replaced. As the water filter nears the end of its useful life and becomes clogged with particles, less water is delivered to the ice maker during each cycle. Remember, if it's been six months or longer since you last changed your water filter, replace the water filter with a new one. Poor quality household water may require the filter to be changed more frequently.

Ice maker/dispenser tips

- If your refrigerator is not connected to a water supply or the water supply is turned off, turn off the ice maker as described in the previous section.
- The following sounds are normal when the ice maker is operating:
 - Motor running
 - Ice dropping into ice bin
 - Water valve opening or closing
 - Running water
- If you need a large quantity of ice at one time, it is best to get cubes directly from the ice bin.
- Ice cubes stored too long may develop an odd flavor. Empty the ice bin as explained below.
- When dispensing cubed ice, it is normal to have a small quantity of little pieces along with the whole cubes.
- To avoid splashing, dispense ice into your container before adding liquids.
- It is normal for ice to fill to the top of the ice bin.

CAUTION: If the water supply to your refrigerator is softened, be sure the softener is properly maintained. Chemicals from a water softener can damage the ice maker.

Cleaning the ice maker

Clean the ice maker and ice bin at regular intervals, especially prior to vacation or moving.

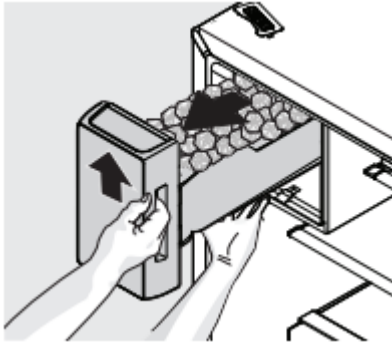

Removing Ice Bin

1. Turn off the ice maker.
2. Lift the ice bin upward then pull straight out to remove.
3. Empty and carefully clean the ice bin with mild detergent. Do not use harsh or abrasive cleaners. Rinse with clean water.
4. Allow the ice bin to dry completely before replacing in the freezer.
5. Replace the ice bin. Turn the ice maker on.

Remove and empty the ice bin if:

- An extended power failure (one hour or longer) causes ice cubes in the ice bin to melt and refreeze together after power is restored, jamming the dispenser mechanism.
- You do not use the ice dispenser frequently. Ice cubes will freeze together in the bin, jamming the dispenser mechanism.

CAUTION:

NEVER use an ice pick or similar sharp instrument to break up the ice. This could damage the ice bin and dispenser mechanism.

To loosen stuck ice, use warm water. Before replacing the ice bin, make sure it is completely dry

IMPORTANT: When removing or replacing the ice bin, avoid rotating the auger in the ice bin. If the auger is accidentally rotated, you must realign the auger by turning it in 45 degree turns (see below) until the ice bin fits into place with the drive mechanism. If the auger is not properly aligned when replacing the ice bin, the refrigerator will not dispense ice. The refrigerator door also may not close properly causing warm air to leak into the refrigerator compartment.

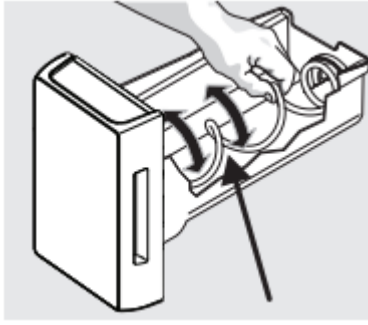

Adjusting Ice Bin Auger

ICE MAKER

Freezer Ice Maker (Non-Dispenser Models Only)

Freezer Ice Maker

Ordering Optional Freezer Ice Maker

Order optional freezer ice maker online at frigidaire/store, by calling 1-800-374- 4432 or through the dealer from which the refrigerator was purchased.

Ice Maker Operation & Care

After the refrigerator is installed properly, the ice maker can produce ice within 24 hours. When using the ice maker for the first time, and in order for it to work properly, it is necessary to clear air from the water tubing and the filter. Furthermore, if the system is not flushed, the first ice cubes may be discolored or have an odd flavor. Once the ice maker begins making ice, allow the bin to fill completely, then discard the first FULL bin of ice.

Ice Maker and Storage Bin Capacity

This ice maker should produce between 2 and 2.5 pounds of ice per 24 hours depending on usage conditions. For a Standard Depth unit, the ice bin should hold around 12 pounds of ice. For a Counter Depth unit, the ice bin should hold around 9 pounds of ice.

NOTE: The ice maker will only produce the advertised production rate if the product is set at 0°F.

NOTE: The Freezer Ice maker fills from the back left-hand corner of the bin. Moving the ice to the edges of the bin allows the bin to fill completely.

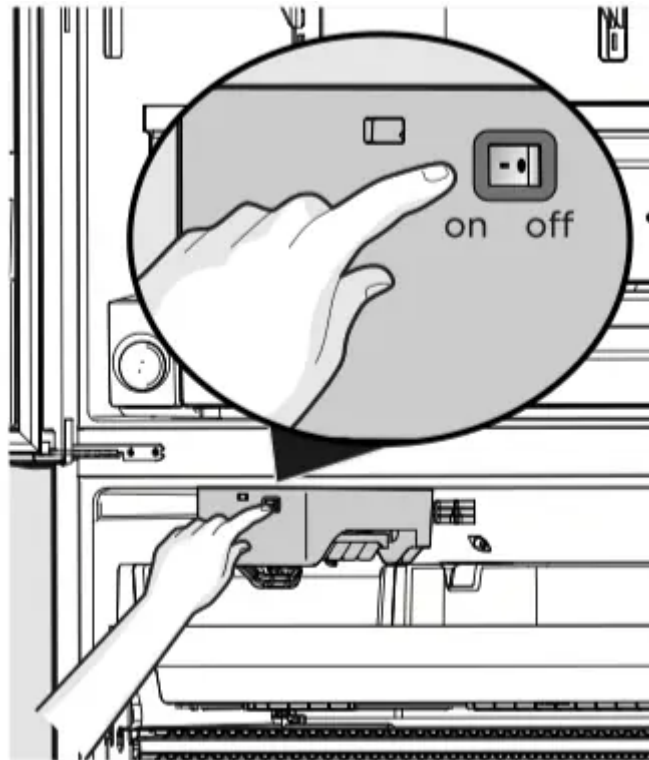

Turning the ice maker on and off

Press power button to turn Ice Maker on (button will not illuminate).

Ice maker tips

- The following sounds are normal when the ice maker is operating:
 - Motor running
 - Ice dropping into ice bin
 - Water valve opening or closing
 - Running water
- Ice cubes stored too long may develop an odd flavor. Empty the ice bin as explained below.

CAUTION: If the water supply to your refrigerator is softened, be sure the softener is properly maintained. Chemicals from a water softener can damage the ice maker.

Cleaning the ice maker bin

Clean the ice maker and ice bin at regular intervals, especially prior to vacation or moving.

1. Turn off the ice maker.
2. Remove the ice bin.
3. Empty and carefully clean the ice bin with mild detergent. Do not use harsh or abrasive cleaners. Rinse with clean water.
4. Allow the ice bin to dry completely before replacing in the freezer.

5. Replace the ice bin. Turn the ice maker on.

Remove and empty the ice bin if an extended power failure (one hour or longer) causes ice cubes in the ice bin to melt and refreeze together after power is restored.

CAUTION

NEVER use an ice pick or similar sharp instrument to break up the ice. This could damage the ice bin.

To loosen stuck ice, use warm water. Before replacing the ice bin, make sure it is completely dry.

STORAGE FEATURES

Shelves

CAUTION

To avoid personal injury or property damage, handle tempered glass shelves carefully. Shelves may break suddenly if nicked, scratched, or exposed to sudden temperature change. Allow the glass shelves to stabilize to room temperature before cleaning. Do not wash in dishwasher.

You can easily adjust shelf positions in the refrigerator compartments to suit your needs. The shelves have mounting brackets that attach to slotted supports at the rear of each compartment.

Change the Position of a Shelf

1. Remove all food from shelf.
2. Lift the front edge up and pull the shelf out.

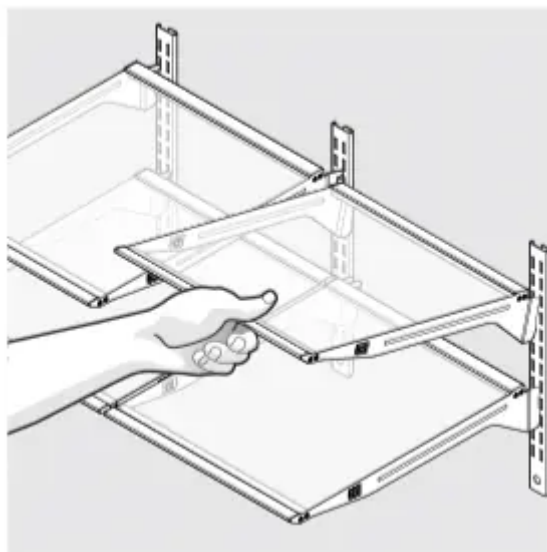

3. Replace by inserting the mounting bracket hooks into the desired support slots.

4. Lower the shelf and lock into position.

Reposition the Air Seal

For glass shelves:

1. Remove air seal by pushing seal straight back.
2. Position the air seal towards the outside edge of the shelf to avoid the air tower when shelf is pushed back into place.
3. Install seal by sliding the open channel end of the seal onto back edge of shelf until seal sits snug on back of shelf and flap sits at about a 10 degree angle from shelf surface.

IMPORTANT: Be aware of the air seal located at the rear of the shelf. Shelves located on the left side should have the air seal mounted on the far left side. Shelves located on the right side should have the air seal mounted on the far right side. This is to ensure there is no interference with the large air tower on the back wall of the cabinet. This also applies to the crisper shelves.

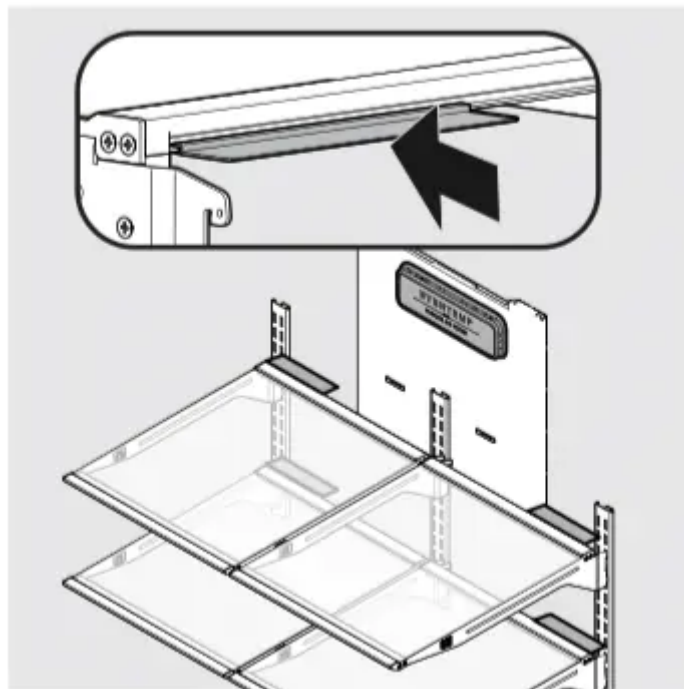

Drawers

Your refrigerator includes a variety of storage drawers.

Crispers

Crisper drawers are designed for storing fruits, vegetables, and other fresh produce.

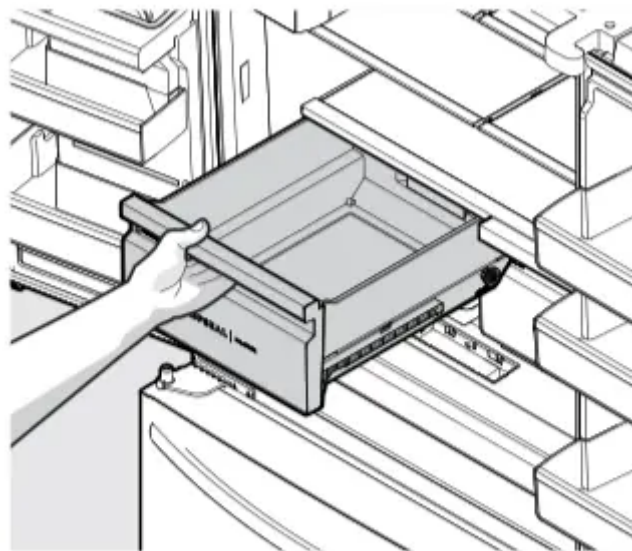

Opening Crisper Drawer

Crisper Humidity Control

Crisper drawers include a sliding control for adjusting the humidity inside the crisper. Leafy vegetables keep best when stored with the Humidity Control set on Higher Humidity. Fresh fruits keep best when stored with the Humidity Control set on Lower Humidity.

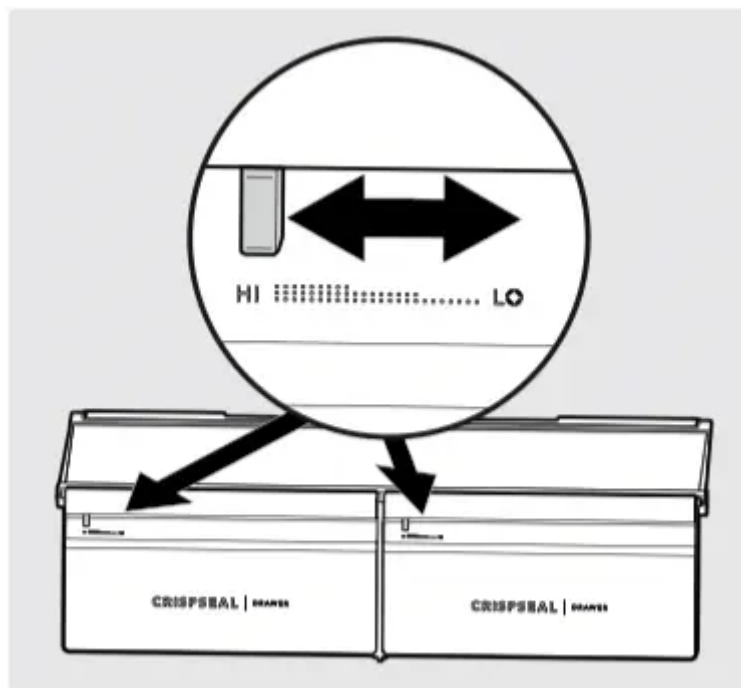

To remove the Crisper Drawer with Pure Air Produce Keeper™ for cleaning:

1. Pull the drawer out until it stops.
2. Lift the front slightly and remove the drawer.

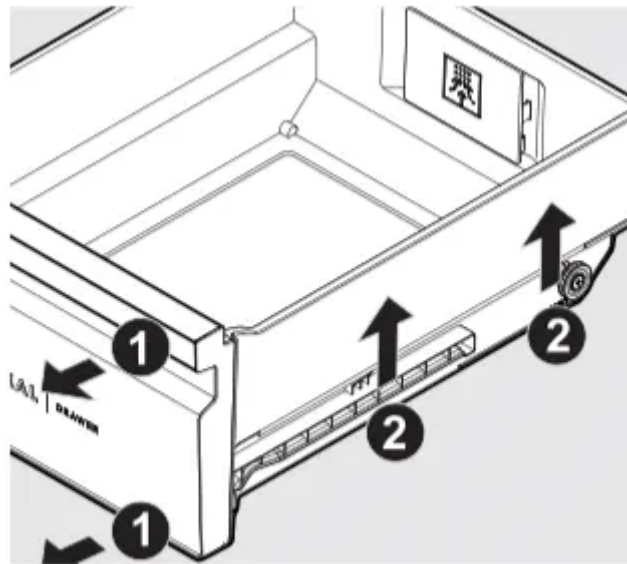

Removing Crisper Drawer

CAUTION: Remove the produce keeper prior to washing the crisper drawer.

To replace the Crisper Drawers with Pure Air Produce Keeper™ after cleaning:

1. Place the crisper drawer on top of the deli cover and tilt upwards slightly.

NOTE: Gasket should be on the outside wall of the crisper after being removed and re-installed into the unit.

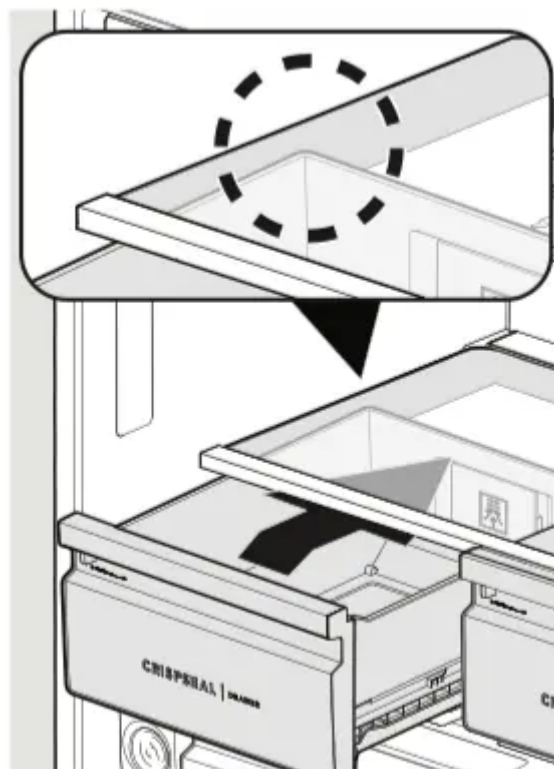

2. Push the crisper straight once the bottom rollers clear the front deli crisper support rollers.

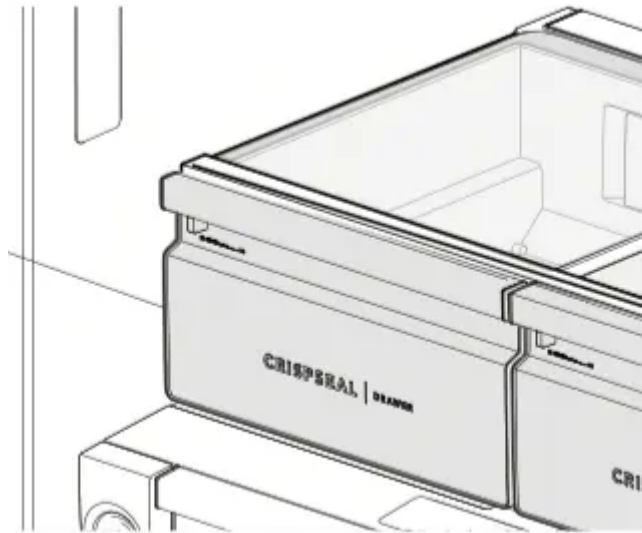

Deli drawer

Ideal for storage of deli meats, cheese, and beverages.

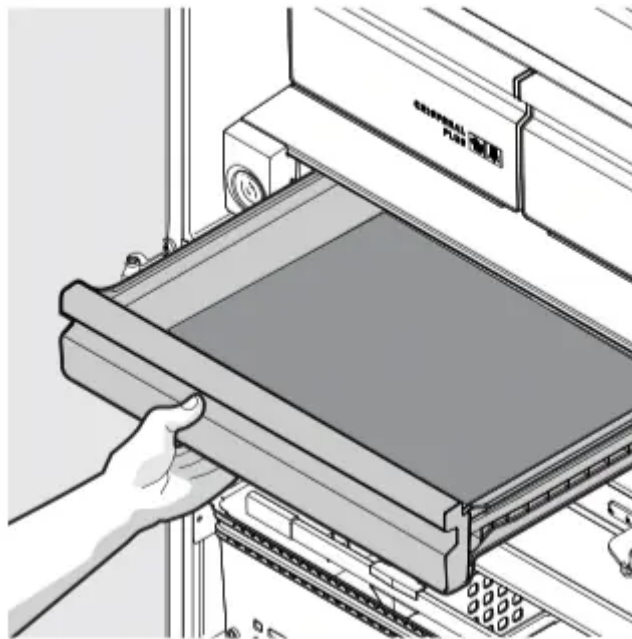

Doors

Storage bins (varies by model)

The doors to your refrigerator compartment use a system of modular storage bins. All of these bins are removable for easy cleaning. Some of them have fixed positions, while others can be adjusted to your needs.

Door bins are ideal for storing jars, bottles, cans, and large drink containers. They also enable quick selection of frequently used items.

To change the position of an adjustable door bin:

1. Remove all food from door bin.
2. Grip the bin firmly with both hands and lift it upward.
3. Remove the bin.
4. Place the bin just above desired position.
5. Lower the bin onto supports until locked in place.
6. Place bin liner into bin.

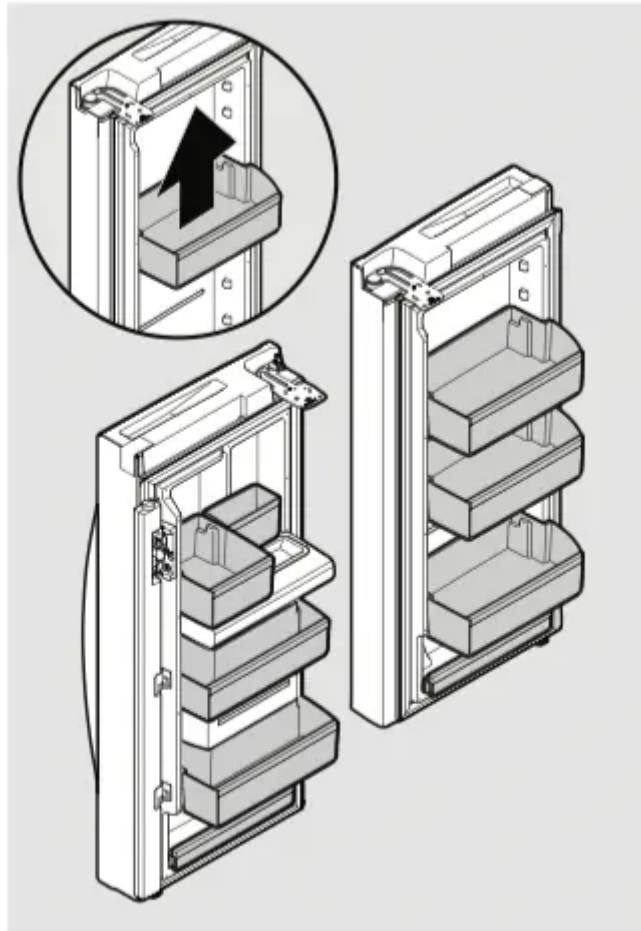

Adjustable Door Bins

Freezer Accessories

Your freezer has baskets and dividers that can be adjusted to your needs.

Remove Upper Freezer Basket

1. Open freezer drawer fully.
2. Extend upper freezer drawer all the way out from the cabinet.

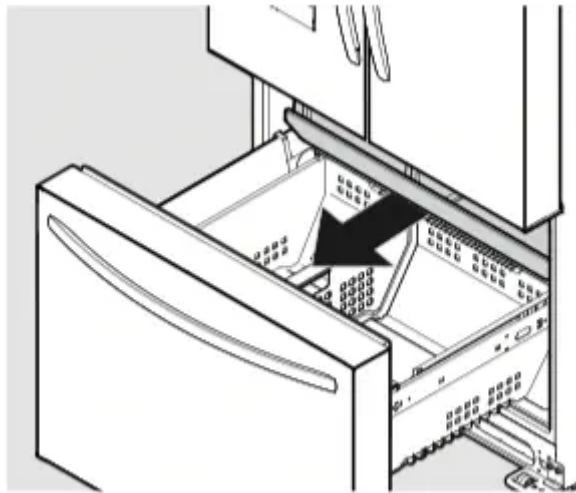

3. Push inward slightly on the basket tabs to release the upper basket from the slide assemblies (1 per side, in front).

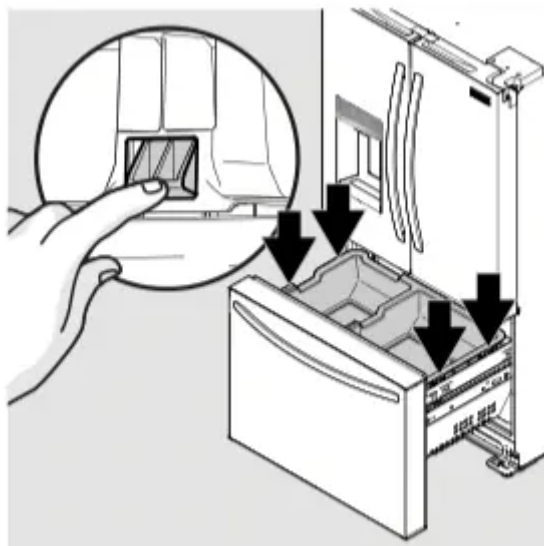

4. Lift basket up and out of freezer compartment.

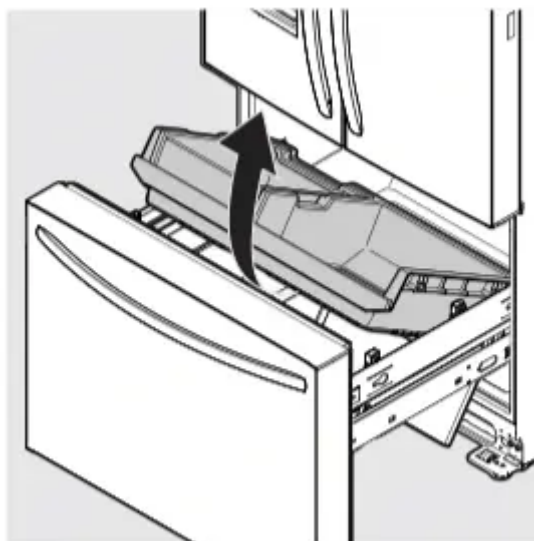

Upper Freezer Basket Replacement

1. Open Freezer drawer completely.

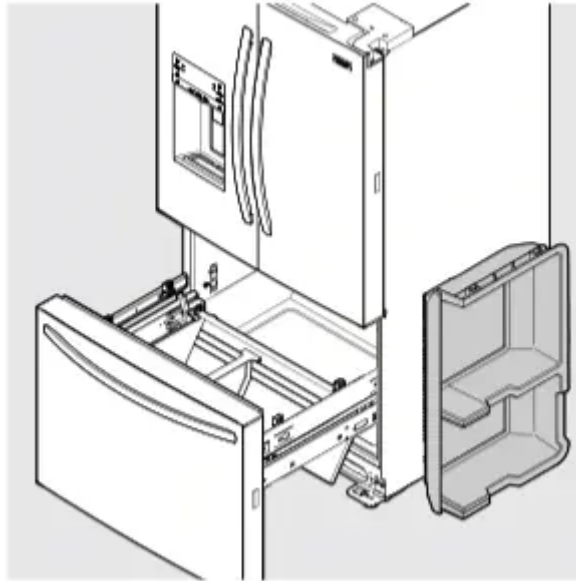

2. Pull both upper slides out of the freezer compartment, extending them fully.
3. Take upper basket assembly and snap basket back into the docks on the slide assemblies. Perform this on one side at a time as slides will move freely during installation.
4. Once basket is fully seated on the upper slide assemblies, push basket back into freezer compartment.

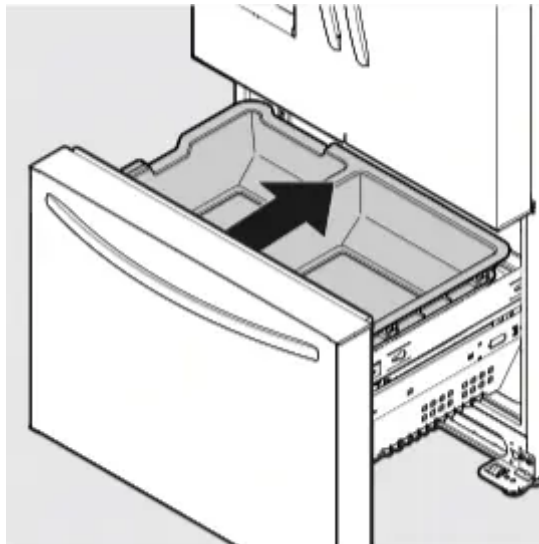

5. Close freezer drawer completely.

To Remove Lower Freezer Basket:

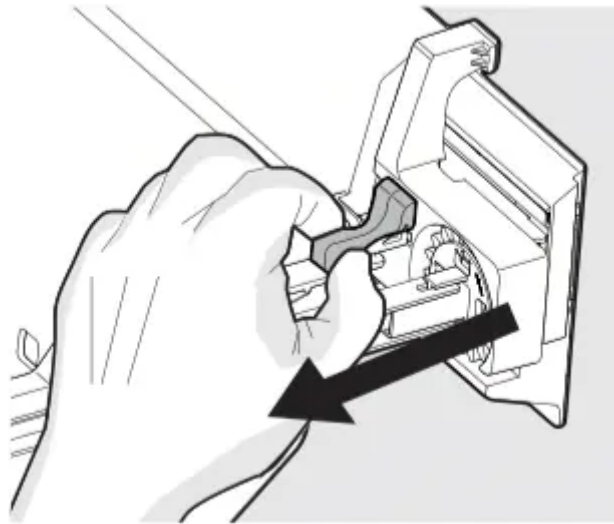

1. Open freezer compartment completely.
2. Locate basket clips in the rear corners of the basket and pull them out to remove.
3. Lift the basket up and remove.

Reverse the steps to reinstall the lower freezer basket.

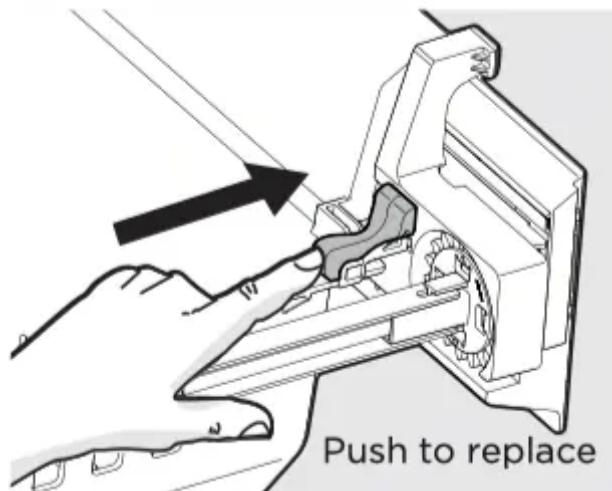

Lower basket Divider

Grab hand hold on lower divider and pull up slightly to slide to next position. (The divider cannot be removed.)

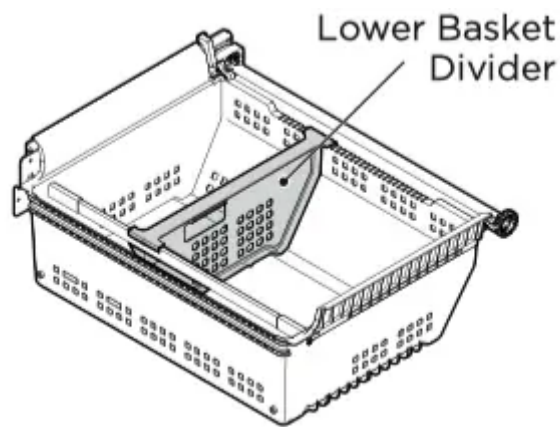

STORING FOOD AND SAVING ENERGY

Ideas for storing foods

Fresh food storage

- Keep the fresh food compartment between 34°F and 40°F with an optimum temperature of 37°F.
- Avoid overcrowding the refrigerator shelves, which reduces air circulation and causes uneven cooling.
- Avoid placing food in front of air ports. (See Controls Section for illustration.)

Fruits and vegetables

- Store fruits and vegetables in crisper drawers, where trapped moisture helps preserve food quality for longer time periods.
- Wash items and remove excess water.
- Wrap any items that have strong odors or high moisture content.

Meat

- Wrap raw meat and poultry separately and securely to prevent leaks and contamination of other foods or surfaces.
- Use the deli drawer to store meat/ poultry for short-term storage. Any meat to be kept longer than two days should be frozen.

Frozen food storage

- Keep the freezer compartment at 0°F or lower.
- A freezer operates most efficiently when it is at least $\frac{2}{3}$ full.

Packaging foods for freezing

- To minimize food dehydration and quality deterioration, use aluminum foil, freezer wrap, freezer bags, or airtight containers. Force as much air out of the packages as possible

and seal them tightly. Trapped air can cause food to dry out, change color, and develop an off-flavor (freezer burn).

- Wrap fresh meats and poultry with suitable freezer wrap prior to freezing.
- Do not refreeze meat that has completely thawed.

Loading the freezer

- Prior to grocery shopping, activate Freeze Boost so that on your return you can ensure your newly purchased food designated for the freezer will be preserved as quickly as possible.
- Activating Freeze Boost also will help your freezer more efficiently maintain the selected temperature after placing new purchases with pre-existing frozen foods.
- Avoid adding too much warm food to the freezer at one time. This overloads the freezer, slows the rate of freezing, and can raise the temperature of frozen foods.
- Leave a space between packages, so cold air can circulate freely, allowing food to freeze as quickly as possible.

Ideas for saving energy

Installation

- Locate the refrigerator in the coolest part of the room, out of direct sunlight, and away from heating ducts or registers.
- Do not place the refrigerator next to heat-producing appliances such as a range, oven, or dishwasher. If this is not possible, a section of cabinetry or an added layer of insulation between the two appliances will help the refrigerator operate more efficiently.
- Level the refrigerator so that the doors close tightly.

Temperature settings

- Refer to the “Controls” section for procedures on temperature settings.

Food storage

- Avoid overcrowding the refrigerator or blocking cold air vents. Doing so causes the refrigerator to run longer and use more energy.
- Cover foods and wipe containers dry before placing them in the refrigerator. This cuts down on moisture build-up inside the unit.
- Organize the refrigerator to reduce door openings. Remove as many items as needed at one time and close the door as soon as possible.
- Do not place a hot container directly on a cold shelf. Remember, such an extreme temperature change may damage the glass.

NORMAL OPERATING SOUNDS

NOTE: Energy efficient foam in your refrigerator is not a sound insulator.

NOTE: During automatic defrost cycle, a red glow in the back wall vents of your freezer compartment is normal.

Understanding the sounds you may hear

Your new, high-efficiency refrigerator may introduce unfamiliar sounds. These sounds normally indicate your refrigerator is operating correctly. Some surfaces on floors, walls, and kitchen cabinets may make these sounds more noticeable.

The following is a list of major components in your refrigerator and the sounds they can cause:

- A. Evaporator** Refrigerant through the evaporator may create a boiling or gurgling sound.
- B. Evaporator fan** You may hear air being forced through the refrigerator by the evaporator fan.
- C. Defrost heater** During defrost cycles, water dripping onto the defrost heater may cause a hissing or sizzling sound. After defrosting, a popping sound may occur.
- D. Automatic ice maker** When ice has been produced, you will hear ice cubes falling into the ice bin. Ice maker fan, water valve activation, and refrigerant gas fluid may create sounds from its operation.
- E. Electronic control & automatic defrost control** These parts can produce a snapping or clicking sound when turning the cooling system on and off.
- F. Condenser fan** You may hear air being forced through the condenser.
- G. Compressor** Modern, high-efficiency compressors run much faster than older models. The compressor may have a high-pitched hum or pulsating sound.
- H. Water valve** Makes a buzzing sound each time it opens to fill the ice maker.
- I. Drain pan (not removable)** You may hear water dripping into the drain pan during the defrost cycle.
- J. Condenser** May create minimal sounds from forced air.
- K. Motorized damper** May produce a light humming during operation.
- L. Ice dispensing paddle** When dispensing ice, you will hear a snapping, clicking, or popping sound.

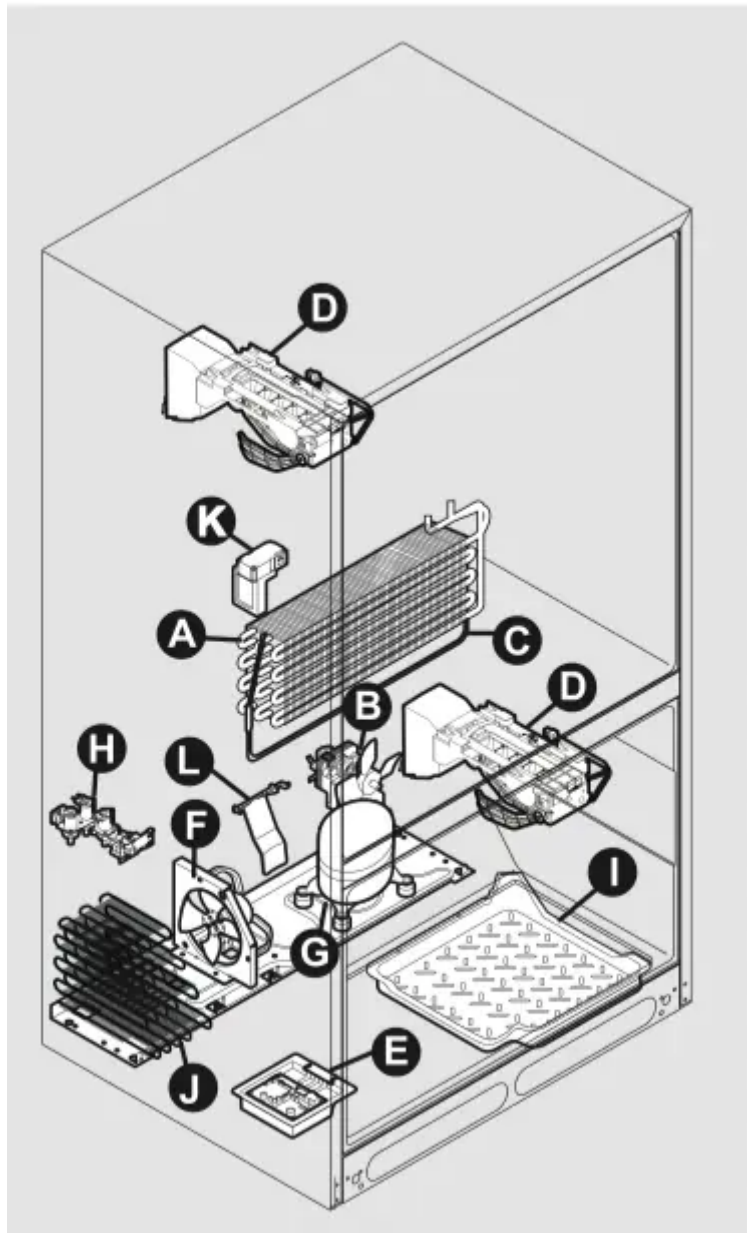

Features vary by model

FILTER REPLACEMENT

Air filter

The air filter is located at the top of the air tower.

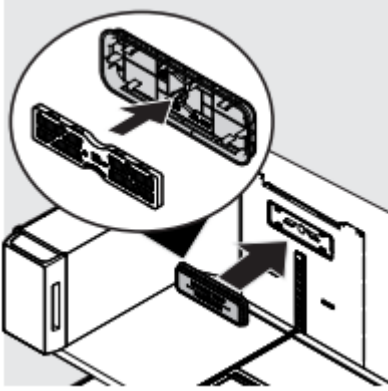

Replacing your PureAir™ AF-2 Air Filter

To ensure optimal filtering of refrigerator odors, you should change the air filter every six months (the filter status light on the main controls prompts you to replace the filter after six months).

To remove and replace the air filter:

1. Place fingers on top of air cover and gently pull towards front of unit releasing the top snaps on the cover from the air tower.
2. Lift bottom snaps up and out of air tower assembly to disengage and remove front cover.
3. Replace air filter by snapping filter into snaps on air filter cover.
4. Installation of front cover is reverse of removal.
5. To reset Air Filter status, refer to instructions under “Controls Section”.

Ordering replacement filters

Order new filters by calling 877-808- 4195, online at [www.frigidaire.com/ store](http://www.frigidaire.com/store), or through the dealer where you bought your refrigerator. You may want to consider ordering extra filters when you first install your refrigerator.

Air Filter Replacement cartridge, part # FRGPAAF2

Locating the Water Filter

Your refrigerator is equipped with water filtering system. The water filter system filters all dispensed drinking water, as well as the water used to produce ice.

The water filter is located at the left side of the Deli Drawer.

PurePour™ Water Filter

Keep safe, great-tasting water flowing with a **PurePour™** water filter. Using a **PurePour™** water filter:

- **Makes Safe Water Second Nature** **PurePour™** water filters are certified to reduce contaminates* and keep great-tasting water flowing for you and your family.
- **Produces Purity You Can Trust**

Know for certain your **PurePour™** water filter is a protector. Counterfeits and knockoffs put your refrigerator and health at risk. Frigidaire Genuine Filters are the smarter, safer choice.

- **Every Drop Gives Back**

Partnered on sustainability efforts, the use of a **PurePour™** water filter helps cut back on the cost and use of plastic used to produce and package bottled water

*For the complete list, please see Performance DataSheet on Frigidaire.com

Replacing the Water Filter

The water filter is located at the bottom left of the refrigerator compartment next to the Deli Drawer. In general, you should change the water filter every 6 months to ensure the highest possible water quality. **Water Filter Status** on the user interface prompts you to replace the filter after a standard amount of water (125 gal/453 L for **PurePour™**) has flowed through the system.

If you have not used your refrigerator for a period of time (during moving for example), change the filter before reinstalling the refrigerator.

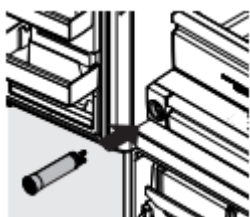

Ordering Replacement Filters

To order your replacement filters, please visit our online store at frigidaire.com, by calling toll-free at 1 (800) 372-4432, or by visiting the dealer where you purchased your refrigerator. Frigidaire recommends that you order extra filters when you first install your refrigerator, and that you replace your filters at least once every 6 months.

Here are the product numbers to request when ordering:

PurePour™ Water Filter PWF-1 Part# **FPWFUO1™**

NOTE: When you order your replacement filter, please reorder the same filter type currently in your refrigerator.

More about your Advanced Water Filter

The **PurePour™** ice and water filter system is tested and certified to NSF/ANSI Standards 42, 53, 401 and CSA B483.1 for the reduction of claims specified on the performance data sheet. Visit frigidaire.com for more information

Do not use with water that is microbiologically unsafe or of unknown quality without adequate disinfection before or after the system. Use systems certified for cyst reduction on disinfected waters that may contain filterable cysts.

Test & certification results:

- Rated Capacity - 125 gal/453 L for **PurePour™** and ice and water filter
- Rated service flow - .50 gal/min.
- Operating Temp.: Min. 33°F, Max. 100°F
- Maximum Rated Pressure - 100 lbs/ in.²
- Recommended Minimum Operating Pressure: 30 lbs/in²

Replacing your PurePour™ water filter

It is not necessary to turn the water supply off to change the filter. Be ready to wipe up any small amounts of water released during the filter replacement.

1. Turn **Off** the ice maker(s).
2. Remove the filter by pushing on the end/face of the filter.
3. Slide the old water filter cartridge straight out of the housing and discard it.
4. Unpackage the new filter cartridge. Using the alignment guide, slide it gently into the filter housing until it stops against the snap-in connector at the back of the housing.
5. Push firmly until the cartridge snaps into place (you should hear a click as the cartridge engages the snap-in connector).
6. Press a drinking glass against the water dispenser while checking for any leaks at the filter housing. Any spurts and sputters that occur as the system purges air out of the dispenser system are normal.
7. After filling one glass of water, continue flushing the system for about **4 minutes**.
8. Turn **On** the ice maker(s).
9. Press and hold the **Water Filter** reset button on the Ice & Water Dispenser control panel for 3 seconds. When the display changes from red to green, the status has been reset.

NOTE

PureAir Produce Keeper™ accessories are optional and may be installed in most models at any time. Visit Frigidaire.com for information about PureAir Produce Keeper™ PK-1 accessories.

Part # FRPAPKRF.

PureAir Produce Keeper™

Keep fruits and vegetables fresher longer with **PureAir Produce Keeper™**. Our produce keeper absorbs ethylene gas, the natural gas that causes produce to ripen quicker. Reduce food waste, save money and enjoy fresh-tasting produce with a longer storage life.

Ordering Replacement Filters

To order your replacement filters, please visit our online store at frigidaire.com, by calling toll-free at 1 (800) 372-4432, or by visiting the dealer where you purchased your refrigerator. Frigidaire recommends that you replace your filters at least once every 6 months.

Here are the product numbers to request when ordering:

PureAir Produce Keeper™ PK-1

Part # **FRPAPKRF**.

Installing the PureAir Produce Keeper™:

1. Remove the plastic wrapper. Insert unopened packet into the holder in the Crisper Drawer.
2. For optimal results, replace the refill every 6 months along with your air filter.

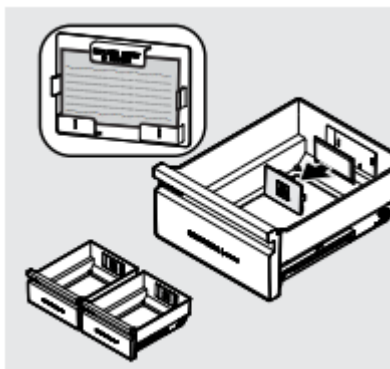

CAUTION:

DO NOT OPEN. Contents may irritate eyes or skin. Keep out of reach of children.

FIRST AID: Contains potassium permanganate. In case of contact with eyes or skin, rinse immediately with water.

DO NOT EAT: If swallowed, seek medical treatment immediately.

CARE & CLEANING

Protecting your investment

Keeping your refrigerator clean maintains its appearance and prevents odor build-up.

NOTE: Do not use abrasive cleaners such as window sprays, scouring cleansers, flammable fluids, cleaning waxes, concentrated detergents, bleaches, or cleansers containing petroleum products on plastic parts, interior doors, gaskets, or cabinet liners. Do not use paper towels, scouring pads, or other abrasive cleaning materials.

Wipe up any spills immediately and clean the freezer and fresh food compartments at least twice a year.

- Never use metallic scouring pads, brushes, abrasive cleaners, or strong alkaline solutions on any surface.
- Never use CHLORIDE or cleaners with bleach to clean stainless steel.

NOTE: If you set your temperature controls to turn off cooling, power to lights and other electrical components will continue until you unplug the power cord from the wall outlet.

- Do not wash any removable parts in a dishwasher.
- Always unplug the electrical power cord from the wall outlet before cleaning.
- Remove adhesive labels by hand. Do not use razor blades or other sharp instruments which can scratch the appliance surface.
- Do not remove the serial plate. Removal of your serial plate voids your warranty.
- Before moving your refrigerator, raise the anti-tip brackets so the rollers will work correctly. This will prevent the floor from being damaged.

Refer to the guide on the next page for details on caring and cleaning specific areas of your refrigerator.

CAUTION

- Pull the refrigerator straight out to move it. Shifting it from side to side may damage flooring. Be careful not to move the refrigerator beyond the plumbing connections.
- Damp objects stick to cold metal surfaces. Do not touch refrigerated surfaces with wet or damp hands.

IMPORTANT: If you store or move your refrigerator in freezing temperatures, be sure to completely drain the water supply system. Failure to do so could result in water leaks when the refrigerator is put back into service. Contact a service representative to perform this operation.

Vacation and moving tips

Occasion	Tips
Short Vacations	<ul style="list-style-type: none"> • Leave refrigerator operating during vacations of three weeks or less. • Use all perishable items from refrigerator compartment. • Turn automatic ice maker off and empty ice bucket, even if you will only be gone a few days.
Long Vacations	<ul style="list-style-type: none"> • Remove all food and ice if you will be gone one month or more. • Turn the cooling system off (see “Controls” section for location of On/ Off button) and disconnect power cord. • Turn water supply valve to closed position. • Clean interior thoroughly. • Leave both doors open to prevent odors and mold build-up. Block doors open if necessary.
Moving	<ul style="list-style-type: none"> • Unplug unit • Remove all food and ice. • Recommend use of a handcart, load from the side. • Adjust rollers all the way up to protect them during sliding or moving. • Pad cabinet to avoid scratching surface.



Care & Cleaning Tips		
Part	What To Use	Tips and Precautions
Interior & Door Liners	<ul style="list-style-type: none"> • Soap and water • Baking soda and water 	Use two tablespoons of baking soda in one quart of warm water. Be sure to wring excess water out of sponge or cloth before cleaning around controls, light bulb or any electrical part.
Door Gaskets	<ul style="list-style-type: none"> • Soap and water 	Wipe gaskets with a clean soft cloth.
Drawers & Bins	<ul style="list-style-type: none"> • Soap and water 	Use a soft cloth to clean drawer runners and tracks.
Glass Shelves	<ul style="list-style-type: none"> • Soap and water • Glass cleaner • Mild liquid sprays 	Allow glass to warm to room temperature before immersing in warm water.
Toe Grille	<ul style="list-style-type: none"> • Soap and water • Mild liquid sprays • Vacuum attachment 	Vacuum dust from front of toe grille. Remove toe grille (see Installation Instructions). Vacuum backside, wipe with sudsy cloth or sponge. Rinse and dry.
Exterior & Handles	<ul style="list-style-type: none"> • Soap and water • Non Abrasive Glass Cleaner 	Do not use commercial household cleaners containing ammonia, bleach or alcohol to clean handles. Use a soft cloth to clean smooth handles. DO NOT use a dry cloth to clean smooth doors.



Part	What To Use	Tips and Precautions
<p>Exterior & Handles</p> <p>(Stainless Steel Models Only)</p>	<ul style="list-style-type: none"> • Soap and water • Stainless Steel Cleaners 	<p>Never use CHLORIDE or cleaners with bleach to clean stainless steel.</p> <p>Clean stainless steel front and handles with non-abrasive soapy water and a dishcloth. Rinse with clean water and a soft cloth. Use a non-abrasive stainless steel cleaner. These cleaners can be purchased at most home improvement or major department stores. Always follow manufacturer's instructions. Do not use household cleaners containing ammonia or bleach.</p> <p>NOTE: Always clean, wipe and dry with the grain to prevent scratching. Wash the rest of the cabinet with warm water and mild liquid detergent. Rinse well, and wipe dry with a clean soft cloth.</p>

TROUBLESHOOTING

Let us help you troubleshoot your concern! This section will help you with common issues. If you need us, visit our website, chat with an agent, or call us. We may be able to help you avoid a service visit. If you do need service, we can get that started for you!



Concern	Potential Cause	Common Solution
Automatic Ice Maker		
Ice maker is not making any ice.	<ul style="list-style-type: none"> • Ice maker is turned off. • Refrigerator is not connected to water line or water valve is not open. • The water supply line is kinked. • The water filter is not seated properly. • The water filter may be clogged with foreign material. 	<ul style="list-style-type: none"> • Turn on ice maker. For the refrigerator ice maker, press and hold the Ice Maker On-Off button on your display. For the freezer ice maker, turn the ice maker on by pressing the toggle switch on the (-) side. • Connect the unit to the household water supply and ensure the water valve is open. • Ensure that the supply line does not kink when the refrigerator is pushed into place against the wall. • Remove and re-install the water filter. Be sure to seat it fully into the locked position. • If water dispenses slowly or not at all, or if the filter is six months old or older, it should be replaced.



<p>Ice maker is not making enough ice.</p>	<ul style="list-style-type: none"> • Ice maker is producing less ice than you expect. • The water filter may be clogged with foreign material. • Saddle valve on cold water pipe is clogged or restricted by foreign material. • Heavy traffic, opening or closing of the doors excessively. • Freezer control is set too warm (freezer ice maker). • Water pressure is extremely low. Cut-off and cut-on pressures are too low (well systems only). • Reverse osmosis system is in regenerative phase. 	<ul style="list-style-type: none"> • In a Standard Depth model, the refrigerator ice maker should produce 3.0 to 3.4 pounds of ice per 24 hours. In a Counter Depth model, the refrigerator ice maker should produce 2.7 to 3.2 pounds of ice per 24 hours. • In a Standard Depth model, the refrigerator ice bin will hold around 5 pounds of ice. In a Counter Depth model, the refrigerator ice bin will hold around 3.7 pounds of ice. • If water dispenses slower than normal, or if the filter is six months old or older, it should be replaced. • Ensure that the supply line does not kink when the refrigerator is pushed into place against the wall. • Turn off household water line valve. Remove valve. Clean valve. Replace valve if necessary. • Set freezer control to colder setting to improve performance of the ice maker (freezer ice maker). Allow 24 hours for temperature to stabilize. • Have someone turn up the cut-off and cut-on pressure on the water pump system (well systems only). • It is normal for a reverse osmosis system to be below 20 psi during the regenerative phase.
<p>Freezer ice maker will not stop making ice (select models).</p>	<ul style="list-style-type: none"> • Ice maker bail arm is being held down by a package in the freezer that has fallen against ice maker. 	<ul style="list-style-type: none"> • Move any item or frozen ice cubes that may block the bail arm from being in the off or upward position. See Automatic Ice Maker-Freezer section in manual.



	<ul style="list-style-type: none"> • Ice cubes are located in once spot inside the freezer ice bin 	<ul style="list-style-type: none"> • Periodically move ice cubes around the ice bin so that ice maker will continue to make ice.
--	---	---

<p>Ice cubes are freezing together.</p>	<ul style="list-style-type: none"> • Ice cubes are not being used frequently enough or interruption of power for prolonged time. • Ice cubes are hollow (shells of ice with water inside). The hollow cubes break open in the bin and leak their water onto existing ice, which causes it to freeze together. 	<ul style="list-style-type: none"> • Remove ice container and discard ice. The ice maker will produce fresh supply. Ice should be used at least twice weekly to keep the cubes separated. • This generally occurs when the ice maker does not get enough water. This is usually the result of a clogged water filter or restricted water supply. Replace the water filter and if the condition still occurs check for a clogged Saddle Valve, water valve not turned on all the way or kinked water supply line.
--	---	--



Dispenser (Ice & Water)		
<p>Dispenser will not dispense ice.</p>	<ul style="list-style-type: none"> • There is no ice in the bin to be dispensed. • The refrigerator doors are not completely closed. • Dispenser paddle has been pressed too long and the dispenser motor has overheated. 	<ul style="list-style-type: none"> • See the “Ice maker is not making any ice” section above. • Be sure the refrigerator doors are completely closed. • The motor overload protector will reset in about three minutes and then ice can be dispensed.
<p>Ice dispenser is jammed.</p>	<ul style="list-style-type: none"> • Ice has melted and frozen around auger due to infrequent use, temperature fluctuations, and/or power outages. • Ice cubes are jammed between ice maker and back of ice container. 	<ul style="list-style-type: none"> • Remove ice container, thaw, and empty the contents. Clean container, wipe dry, and replace in proper position. When new ice is made, dispenser should operate. • Remove ice cubes that are jamming the dispenser.
<p>Dispenser will not dispense water.</p>	<ul style="list-style-type: none"> • Water filter not seated properly. • Water filter is clogged. • Household water line valve is not open. 	<ul style="list-style-type: none"> • Remove and reinstall the water filter. For PurePour, be sure to push the filter in all the way until it clicks into place and is secured inside of the water filter housing. • Replace filter cartridge. Be sure to push filter all the way in until it clicks into place and is secured inside of the water filter housing. • Open household water line valve. See CONCERN column AUTOMATIC ICE MAKER.



<p>Water not cold enough.</p>	<ul style="list-style-type: none"> • The water dispensing system is not designed to chill water. 	<ul style="list-style-type: none"> • Add ice to cup or container before dispensing water.
<p>Water has an odd taste and/or odor.</p>	<ul style="list-style-type: none"> • Water has not been dispensed for an extended period of time. • Unit not properly connected to cold water line. 	<ul style="list-style-type: none"> • Draw and discard 10-12 glasses of water to freshen the supply. • Connect unit to cold water line that supplies water to the kitchen faucet.



Opening/Closing Of Doors/Drawers		
Door(s) will not close.	<ul style="list-style-type: none"> • Door was closed too hard, causing other door to open slightly. • Refrigerator is not level. It rocks on the floor when moved slightly. • Refrigerator is touching a wall or cabinet. 	<ul style="list-style-type: none"> • Close both doors gently. • Ensure floor is level and solid, and can adequately support the refrigerator. Contact a carpenter to correct a sagging or sloping floor. • Ensure floor is level and solid, and can adequately support the refrigerator. Contact a carpenter to correct a sagging or sloping floor.
Drawers are difficult to move.	<ul style="list-style-type: none"> • Food is touching shelf on top of drawer. • Track that drawers slide on is dirty. 	<ul style="list-style-type: none"> • Remove top layer of items in drawer. • Ensure drawer is properly installed on track. • Clean drawer, rollers, and track. See Care & Cleaning.
Running of Refrigerator		
Compressor does not run.	<ul style="list-style-type: none"> • Freezer control is set to "OF". • Refrigerator is in defrost cycle. • Plug at electrical outlet is disconnected. • House fuse blown or tripped circuit breaker. • Power outage. 	<ul style="list-style-type: none"> • Set freezer control. • This is normal for a fully automatic defrost refrigerator. The defrost cycle occurs periodically, lasting about 30 minutes. • Ensure plug is tightly pushed into outlet. • Check/replace fuse with a 15 amp time-delay fuse. Reset circuit breaker. • Check house lights. Call local electric company.



<p>Refrigerator seems to run too much or too long.</p>	<ul style="list-style-type: none"> • Your variable speed compressor is designed to run 100% of the time except during the defrost cycle. At times it will run faster, such as after a defrost cycle. 	<ul style="list-style-type: none"> • It is normal for the compressor to run continuously except during defrost mode.
---	---	---

<p>Digital Temperature Setting Display</p>		
<p>Digital temperature displays an error.</p>	<ul style="list-style-type: none"> • Electronic control system has detected a performance problem. 	<ul style="list-style-type: none"> • Call your Electrolux service representative, who can interpret any messages or number codes flashing on the digital displays.

<p>Water/Moisture/Frost Inside Refrigerator</p>		
<p>Moisture collects on inside of refrigerator walls.</p>	<ul style="list-style-type: none"> • Weather is hot and humid. • Flipper mullion 	<ul style="list-style-type: none"> • The rate of frost buildup and internal sweating increases. • Adjust flipper mullion. (See “To adjust the flipper mullion” in the Installation section.)
<p>Water collects on bottom side of drawer cover.</p>	<ul style="list-style-type: none"> • Vegetables contain and give off moisture. 	<ul style="list-style-type: none"> • It is not unusual to have moisture on the bottom side of the cover. Move humidity control (some models) to lower setting.
<p>Water collects in bottom of drawer.</p>	<ul style="list-style-type: none"> • Washed vegetables and fruit drain while in the drawer. 	<ul style="list-style-type: none"> • Water collecting in bottom of drawer is normal. Dry items before putting them in the drawer or store produce in tightly sealed bags to help reduce condensation inside of the drawer.
<p>Water/Moisture/Frost Outside Refrigerator</p>		



<p>Moisture collects on outside of refrigerator or between doors.</p>	<ul style="list-style-type: none"> • Weather is humid. 	<ul style="list-style-type: none"> • This is normal in humid weather. <p>When humidity is lower, the moisture should disappear.</p>
<p>Food in Fresh Food Compartment</p>		
<p>Food is freezing.</p>	<ul style="list-style-type: none"> • Temperature setting is too low. • Temperature sensor is covered by food (right side of fresh food area). • Food is covering the air ports. 	<ul style="list-style-type: none"> • Move the setting to a higher degree. • Allow space for air flow to the sensor. • Allow space between the air ports and the food.

Warning

This content is compiled from multiple sources and is provided for reference purposes only. It may not be complete or fully applicable to all situations. If you are unable to resolve your issue, please contact the product manufacturer or an authorized service provider for official support.

