

## Setting up your microwave oven

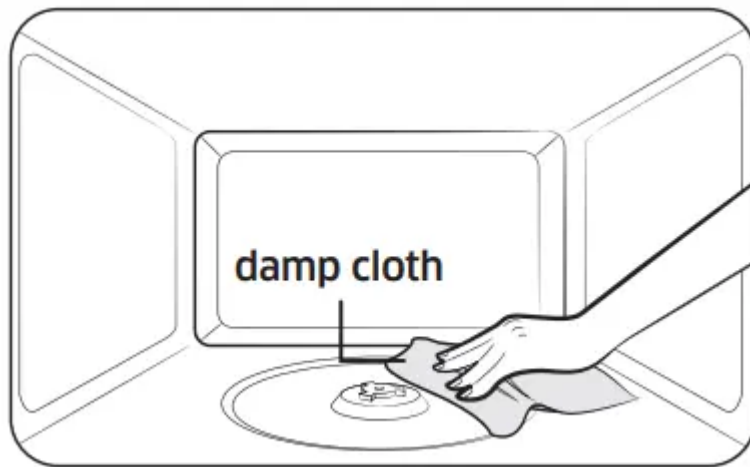

1. Open the door by pulling the handle on the right side of the door.
2. Wipe the inside of your microwave oven with a damp cloth.



3. Install the pre-assembled ring into the indentation at the center of the microwave oven.



4. Fit the center of the glass tray to the coupler.

# Control Panel

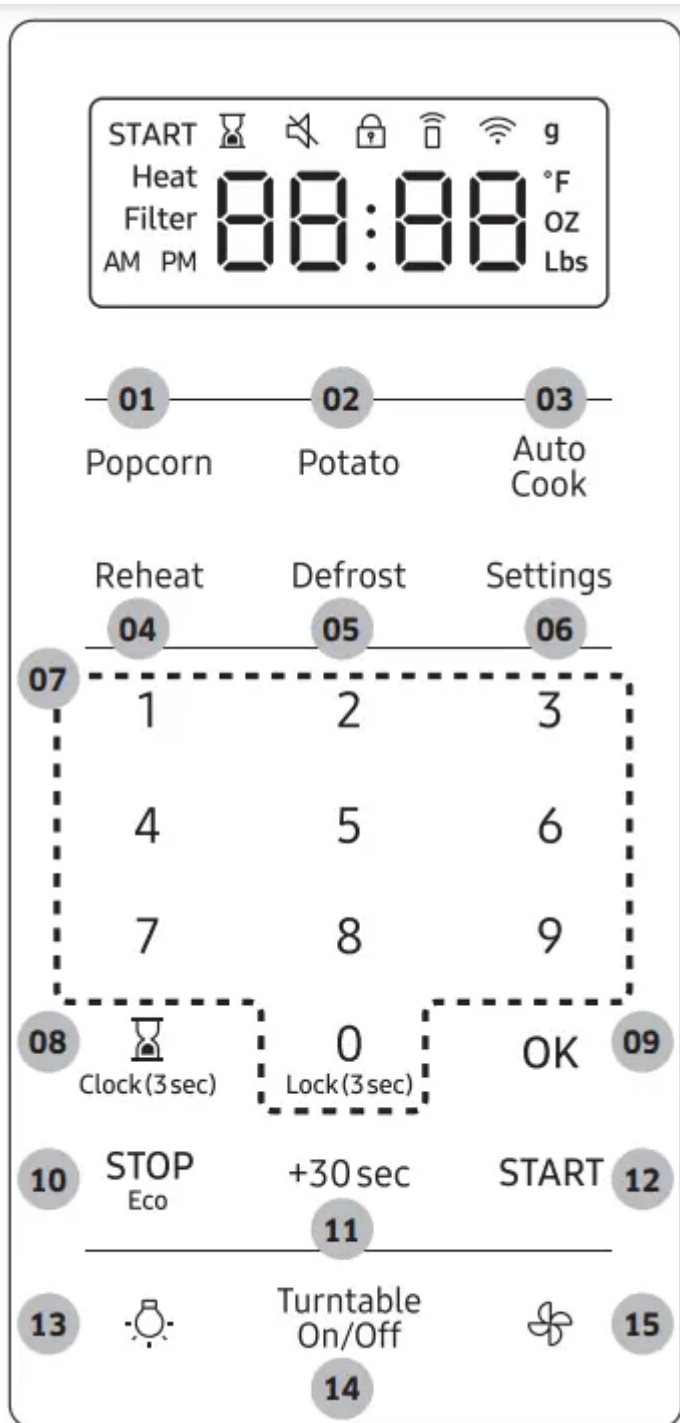

- 01 Popcorn Button
- 02 Potato Button
- 03 Auto Cook Button
- 04 Reheat Button
- 05 Defrost Button
- 06 Settings Button



- **07** Number Pad
- **08** Kitchen Timer/Clock Setting Button
- **09** OK/Child Lock Button
- **10** STOP Eco Button
- **11** +30 sec Button
- **12** START Button
- **13** Light Button (Hi/Low/Off)
- **14** Turntable On/Off Button
- **15** Vent Button (4 Speed & On/Off)

## Using your microwave oven

### Turntable (On/Off)



1. Touch the Turntable On/Off

**NOTE:** You can use this feature only on manual cooking mode. If the turntable does not rotate for an extended period of time, food may burn. For best cooking results, leave the turntable feature on.

**CAUTION:** The turntable may become too hot to touch. Use pot holders to handle the turntable during and after cooking.

### Kitchen Timer

Your microwave has a built-in timer function - the Kitchen Timer. Use the Kitchen Timer for timing up to 99 minutes, 99 seconds.



.1 Touch the  button.

2. Use numeric buttons to set the time.
3. Touch the **OK** button.
4. The display counts down, and then beeps when the time has elapsed.
5. To cancel the timer setting, touch the **STOP** button

## Child Lock

The Child Lock function allows you to lock all buttons so that the microwave oven cannot be operated by children accidentally.



### Activating / Deactivating

If you want to activate or deactivate the child lock function, touch the Lock button for 3 seconds.

The display will show  when the oven is locked.

## Stop Button

The STOP button allows you to clear instructions you have entered. It also allows you to pause your microwave oven's cooking cycle, so that you can check the food.

- To pause the oven during cooking, touch the STOP button once. To restart, touch the START button.
- To stop cooking, erase instructions, and return the oven display to the time of day, touch the STOP button twice.
- To clear instructions you have just entered, touch the STOP button once, and then re-enter the instructions.
- To cancel a timer setting, touch the STOP button once

## Eco Mode



Eco Mode reduces standby power usage. When you touch the **STOP Eco** button once, the display will go out and the microwave shifts to a mode which minimizes power usage. To cancel the Eco mode, touch any other button

## +30 sec

This feature offers a convenient way to increase cooking time in manual cooking mode.



1. In standby mode, touching +30 sec button will add 30 seconds of microwave mode.
2. If the oven is in manual cooking mode, touching +30 sec button will add cooking time by 30 seconds

### Cooktop Lamp (High/Low/Off)





Touch the  button to turn the cooktop lamp on or off. Touch the button once for high, twice for low and three times to turn the cooktop lamp off.v

### Vent Fan (Boost/High/Medium/Low/Off)

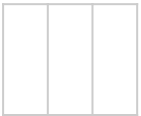
The vent fan removes steam and other vapors that result from cooking on the cooktop below.



Touch the  button once for boost fan, twice for high fan, three times for medium fan and four times for low fan speed. Touch  the button five times to turn the fan off.

**NOTE:** The exhaust fan's speed may decrease when the oven's cooking function is activated.

**NOTE:** The Vent Fan protects the microwave from excess heat. It automatically turns on if it senses too much heat. If you have turned the fan on, you may find that you cannot turn it off. The fan will automatically turn off when the internal parts are cool. It may stay on for 30 minutes or more after the cooktop and microwave controls are turned off

### Popcorn

You can cook popcorn easily using the Popcorn button. You do not need to set either the cooking time or the power level.



1. Put a bag of unpopped popcorn on the tray.
2. Touch the **Popcorn** button and then select size of popcorn by touching numeric button(1 - 3.5 oz / 2 - 3.0 oz / 3 - 1.5 oz).

3. Touch **START** button. The microwave oven will automatically operate by preprogrammed time.

## Potato

You can cook potatoes easily using the Potato button. You do not need to set either the cooking time or the power level.



1. Put potatoes on the tray.
2. Touch **Potato** button.
3. Select food item by touching numeric buttons and then touch **OK** button.
4. Select amount by touching numeric buttons and then touch **START** button. The microwave oven will automatically operate by pre-programmed time.

No	Food	Amount	Instructions
1	<b>Baked potatoes</b>	2 ea	Pierce each potato several times with a fork. Place on the turntable in a spoke-like fashion. After cooking, let the potatoes stand for 3-5 minutes
		4 ea	
2	<b>Sweet potatoes</b>	2 ea	Pierce each sweet potato several times with a fork. Place on the turntable in a spoke-like fashion. After cooking, let the potatoes stand for 3-5 minutes.
		4 ea	

## Auto Cook

The Auto Cook button lets you cook favorite foods using preset power levels and times. If the food is not thoroughly cooked after using Auto Cook feature, complete the cooking process by cooking the food for an additional amount of time.



1. Put the food on the tray.
2. Touch **Auto Cook** button.
3. Select category of food item by touching numeric buttons and then touch **OK** button.
4. Select food item by touching **numeric** buttons and then touch **OK** button.
5. Select amount by touching **numeric** buttons and then touch **START** button. The microwave oven will automatically operate by pre-programmed time.

Category	Menu	Amount	Instructions
Snack	Fish sticks	1 serving	Place the fish sticks on the microwave safe dish. Place the dish on the center of the turntable.
		2 servings	
	Quesadillas	1 serving	Follow the package directions. Place the quesadilla on the microwave safe dish. Place the dish on the center of the turntable.
		2 servings	
	Hot dogs	2 each	Pierce the hot dogs 3 times with a fork. Place the hot dogs on the microwave safe dish. Place the dish on the center of the turntable. When the microwave beeps, add the buns and restart the microwave. For the best texture, the buns should be added after the microwave beeps.
		4 each	
	Instant macaroni and cheese	1 serving	Follow the package directions. Place the dish on the center of the turntable. Stir afterwards.
		2 servings	
	Frozen waffles	1 serving	Place the waffles on the microwave safe dish. Place the dish on the center of the turntable.
		2 servings	
	Frozen croquettes	1 serving	Place the croquettes on the microwave safe dish. Place the dish on the center of the turntable.
		2 servings	
	Burritos	1 each	Follow the package directions. Place the burrito on the microwave safe dish. Place the dish on the center of the turntable.
		2 each	
Instant mashed potatoes	2 servings	Follow the package directions. Place the dish on the center of the turntable. Stir afterwards.	
	4 servings		

Category	Menu	Amount	Instructions
Fresh Vegetables	Broccoli	1 serving	Wash and clean the broccoli. Place the broccoli florets in the microwave safe bowl. Add 1-4 tbs. of water (1 tbs. per serving). Cover with vented (1 inch vent) plastic wrap while cooking and stir before letting stand.
		2 servings	
		3 servings	
		4 servings	
	Carrots	1 serving	Wash and clean the carrots. Cut the carrots into even slices and place in the microwave safe bowl. Add 1-4 tbs. of water (1 tbs. per serving). Cover with vented (1 inch vent) plastic wrap while cooking and stir before letting stand.
		2 servings	
		3 servings	
		4 servings	
	Green beans	1 serving	Wash and clean the green beans. Place the green beans in the microwave safe bowl. Add 1-4 tbs. of water (1 tbs. per serving). Cover with vented (1 inch vent) plastic wrap while cooking and stir before letting stand.
		2 servings	
		3 servings	
		4 servings	
	Spinach	1 serving	Wash and clean the spinach. Place the spinach in a microwave safe bowl. Add 1-4 tbs. of water (1 tbs. per serving). Cover with vented (1 inch vent) plastic wrap while cooking and stir before letting stand.
		2 servings	
		3 servings	
		4 servings	
Squash	2 servings	Slice the squash in half and remove the seeds. Place the squash cut side down in a microwave safe dish and add ¼ cup of water. Cover with vented (1 inch vent) plastic wrap while cooking and stir before letting stand.	
	4 servings		

Category	Menu	Amount	Instructions
Frozen Vegetables	Broccoli	1 serving	Place the broccoli in the microwave safe bowl. Add 1-4 tbs. of water (1 tbs. per serving). Cover with vented (1 inch vent) plastic wrap while cooking and stir before letting stand.
		2 servings	
		3 servings	
		4 servings	
	Carrots	1 serving	Place the carrots in the microwave safe bowl. Add 1-4 tbs. of water (1 tbs. per serving). Cover with vented (1 inch vent) plastic wrap while cooking and stir before letting stand.
		2 servings	
		3 servings	
		4 servings	
	Corn	1 serving	Place the corn in the microwave safe bowl. Add 1-4 tbs. of water (1 tbs. per serving). Cover with vented (1 inch vent) plastic wrap while cooking and stir before letting stand.
		2 servings	
		3 servings	
		4 servings	
	Green beans	1 serving	Place the green beans in the microwave safe bowl. Add 1-4 tbs. of water (1 tbs. per serving). Cover with vented (1 inch vent) plastic wrap while cooking and stir before letting stand.
		2 servings	
		3 servings	
		4 servings	
	Peas	1 serving	Place the peas in the microwave safe bowl. Add 1-4 tbs. of water (1 tbs. per serving). Cover with vented (1 inch vent) plastic wrap while cooking and stir before letting stand.
		2 servings	
		3 servings	
		4 servings	



Category	Menu	Amount	Instructions
Meal	Oatmeal	1 pack	Follow the package directions for the recommended amount of water needed. Stir well before cooking and afterwards.
		2 packs	
	Quinoa	2 servings	Follow the package directions for the recommended amount of water needed. Stir well before cooking and afterwards.
		4 servings	
	Frozen dinner	12 oz (340 gram)	Remove the food from its wrapping and follow the instructions on the box for covering and letting stand.
		16 oz (454 gram)	
	Frozen breakfast	5 oz (142 gram)	Use for frozen sandwiches, breakfast entrees, pancakes, waffles, etc. Follow the package instructions for covering and standing.
		8 oz (227 gram)	
	Brown rice	2 servings	Add 1 cup of cold water for 1 cup of rice. Use a large glass bowl. Cover with vented (1 inch vent) plastic wrap. Rice doubles in volume during cooking. After the cooking time is over, stir before standing time, and then salt or add herbs and butter.
		4 servings	

Category	Menu	Amount	Instructions
Meal	Whole wheat macaroni	2 servings	Add 1 cup of cold water for 1 cup of rice. Use a large glass bowl. Cover with vented (1 inch vent) plastic wrap. Carefully remove from the microwave and drain the hot water.
		4 servings	
	Bacon, pre-cooked	2 slices	Layer 2 paper towels on a microwave safe plate and arrange the bacon on the towels. Do not overlap bacon. Cover with an additional paper towel. Remove the paper towel immediately after cooking.
		4 slices	
		6 slices	
	Melt/ Soften	Melt butter	1 stick (¼ lb.)
2 sticks (½ lb.)			
Soften butter		1 stick (¼ lb.)	Remove the butter from the packaging and place on a microwave safe dish.
		2 sticks (½ lb.)	
Melt chocolate		1 cup	Place the chocolate chips in a microwave safe dish. When the microwave oven beeps, stir well, and then press <b>START</b> to continue. Unless stirred, the chocolate chips will keep their shape even when the heating time is over.
Soften ice cream		1 pint	Remove the lid of the carton. Place the carton in the center of the microwave.
		4 pints	

Category	Menu	Amount	Instructions
Melt/ Soften	Soften cream cheese	1 pack	Unwrap the cream cheese and place on a microwave safe dish.
	Soften frozen juice	1 pack	Do not place metal juice cans in the microwave. Remove the plastic lid and place in center of microwave. Stir well afterwards.
	Melt cheese	1 cup	Place the cheese in a microwave safe bowl and cover with wax paper. Stir well afterwards.
	Melt caramel	10 oz (280 gram)	Place the caramel in a large microwave safe dish. Stir well afterwards.
	Melt marshmallows	10 oz (280 gram)	Place the marshmallows in a large microwave safe dish. Stir well afterwards.
Poultry/ Fish	Chicken breasts	4 servings	Pierce the chicken breasts 3 times with a knife. Place the chicken breasts on the microwave safe dish and cover with plastic wrap. Place the dish on the center of the turntable.
	Salmon fillets	1 serving	Put the salmon fillets on the microwave safe dish and cover with plastic wrap. Place the dish on the center of the turntable.
		2 servings	
	White fish fillets	1 serving	Put the white fish fillets on the microwave safe dish and cover with plastic wrap. Place the dish on the center of the turntable.
		2 servings	
	Fresh prawns	1 serving	Place the prawns in the microwave safe dish and cover with plastic wrap. Place the dish on the center of the turntable.
		2 servings	

## Reheat

You can reheat foods easily using the Reheat button. You do not need to set either the cooking time or the power level.



1. Put the food on the tray.
2. Touch **Reheat** button.

3. Select food item by touching **numeric** buttons and then touch **OK** button.

4. Select amount by touching numeric buttons and then touch **START** button. The microwave oven will automatically operate by pre-programmed time.

No	Food	Amount		Instructions
1	Pizza	1	2 slices	Place pizza slices on a microwave safe plate with the wide ends of the slices towards the outside edge of the plate. Do not let the slices overlap. Do not cover.
		2	4 slices	
2	Casserole	1	1 serving	Cover the plate with vented (1 inch vent) plastic wrap. Stir the food once before serving.
		2	2 servings	
		3	3 servings	Contents: Casseroles (refrigerated)
		4	4 servings	

3	Dinner plate	1	1 serving	Use only precooked, refrigerated foods. Cover the plate with vented (1 inch vent) plastic wrap or waxed paper tucked under the plate.  Contents: <ul style="list-style-type: none"> <li>• 3-4 oz. meat, poultry, or fish (up to 6 oz. with bone)</li> <li>• ½ cup starch (potatoes, pasta, rice, etc.)</li> <li>• ½ cup vegetables (about 3-4 oz.)</li> </ul>
4	Pasta	1	1 serving	Cover the plate with vented (1 inch vent) plastic wrap. Stir the food once before serving.  Contents: Pasta (canned spaghetti)
		2	2 servings	
		3	3 servings	
		4	4 servings	
5	Soup, cream	1	1 serving	Cover the bowl with vented (1 inch vent) plastic wrap. Stir the soup once before serving.  Contents: Soup (refrigerated)
		2	2 servings	
		3	3 servings	
		4	4 servings	
6	Soup, broth	1	1 serving	Cover the bowl with vented (1 inch vent) plastic wrap. Stir the soup once before serving.  Contents: Soup (refrigerated)
		2	2 servings	
		3	3 servings	
		4	4 servings	
7	Beverage	1	½ cup	Use a measuring cup or mug and do not cover. Place the beverage in the oven. After heating, stir well.
		2	1 cup	
		3	2 cups	

## Defrost

To thaw frozen foods, enter the weight of the food, and the microwave automatically sets the defrosting time, power level, and standing time.

--	--	--

1. Touch the **Defrost** button.
2. Touch the **numeric** buttons to directly enter the weight of the food. (0.1-6.0 lbs, 0.1-2.7kg. See the table following)
3. Touch **START** button.

4. The oven will beep and the display will show Turn the food over during the defrosting process. Open the oven door, and turn the food over. If you do not turn the food over when Turn the food over is displayed, the microwave will continue until the end of cooking time.

Food	Amount	Instructions
Meat	0.1-6.0 lbs. 0.1-2.7 kg	Shield the edges with aluminium foil. Turn the meat over when the oven beeps. This program is suitable for lamb, pork, steaks, chops, and ground meat. Let stand, covered with foil for 5-10 minutes.

**NOTE:** Check the food when you hear the oven signal. After the final stage, small sections may still be icy; let them stand to continue the thawing process. The food is not defrosted until all ice crystals have melted. Shielding roasts and pieces of steak using small pieces of foil prevents the edges from being cooked before the center of the food has defrosted. Use narrow, flat, smooth strips of aluminum foil to cover edges and thinner sections of the food.

## Microwave

Your microwave oven allows you to set two different cooking stages, each with its own time length and power level. The power level lets you control the heating intensity from Warm (1) to High (10).

## Power levels

The 10 power levels allow you to choose the optimal power level for your cooking needs.

No.	Power Level	Description	No.	Power Level	Description
1	10	Warm	6	60	Simmer
2	20	Low	7	70	Medium high
3	30	Defrost	8	80	Reheat
4	40	Medium low	9	90	Sauté
5	50	Medium	10	100	High

## One-stage cooking

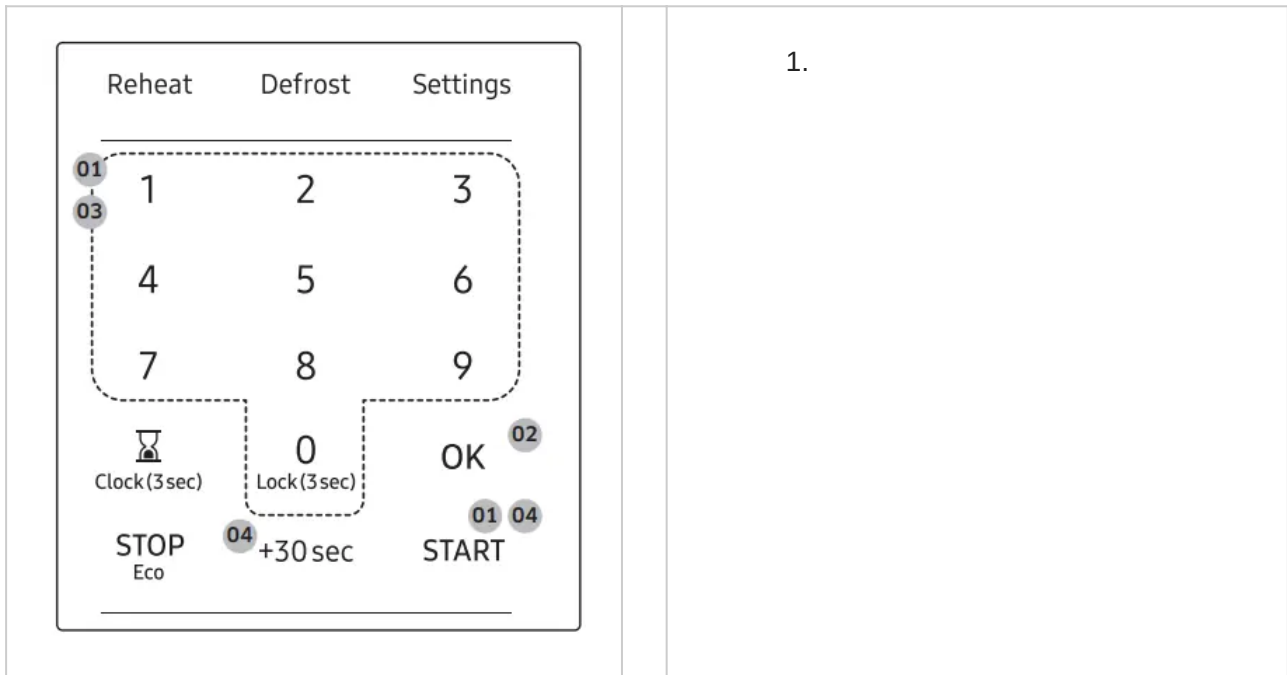

1.

1. In standby mode, touch the numeric buttons to set a cooking time. You can enter a time from one second to 99 minutes and 99 seconds. To select a time greater than one minute, enter the seconds too. (For example, to set a cooking time of 20 minutes, enter 2, 0, 0, 0.) If you do not need to set the power level, just touch the START button. The microwave will automatically operate at the High power level.
2. If you want to set the power level to a level other than High, touch the OK button.
3. Touch the numeric buttons that correspond to the power level you want to use.
4. Touch the START button. If you want to add the cooking time, touch +30 sec button. You can adjust the cooking time while the microwave oven is operating.

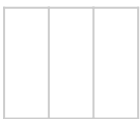

1. In standby mode, touch the **numeric** buttons to set a cooking time. You can enter a time from one second to 99 minutes and 99 seconds. To select a time greater than one minute, enter the seconds too. (For example, to set a cooking time of 20 minutes, enter **2, 0, 0, 0**.) If you do not need to set the power level, just touch the START button. The microwave will automatically operate at the High power level.
2. If you want to set the power level to a level other than High, touch the **OK** button.
3. Touch the **numeric** buttons that correspond to the power level you want to use.
4. Touch the **START** button. If you want to add the cooking time, touch +30 sec button. You can adjust the cooking time while the microwave oven is operating.

## Multi-stage cooking (maximum of 2 stages)

Your oven allows you to set two different cooking stages, each with its own time length and power level. The power level lets you control the heating intensity from Warm to High.

1. Follow steps 1, 2, and 3 from the “One-stage cooking” section.
2. Touch OK button to move to the second stage.
3. Follow steps 1, 2, 3, and 4 from the “One-stage cooking” section.

## Cleaning and maintaining your microwave oven

### Cleaning the exterior

It's best to clean spills on the outside of your microwave oven as they occur. Use a soft cloth and warm, soapy water. Rinse and dry.

**CAUTION:** Do not get water into the vents. Never use abrasive products or chemical solvents such as ammonia or alcohol as they can damage the appearance of your microwave.

**WARNING:** Unplug the microwave plug before cleaning.

### Cleaning under your microwave oven

Regularly clean grease and dust from the bottom of your microwave using a solution of warm water and detergent.

### Cleaning the control panel

Wipe with a damp cloth and dry thoroughly. Do not use cleaning sprays, large amounts of soap and water, abrasives, or sharp objects on the panel as it is easily damaged.

### Cleaning the door and door seals

Always ensure that the door seals are clean and that the door closes properly. Take particular care when cleaning the door seals to ensure that no particles accumulate and prevent the door from closing correctly. Wash the glass door with very mild soap and water. Be sure to use a soft cloth to avoid scratching.

**NOTE:** If steam accumulates inside or outside the oven door, wipe with a soft cloth. Steam can accumulate when you operate the oven when humidity is high and in no way indicates microwave leakage.

### Cleaning the interior

**CAUTION:** To avoid injury, ensure that the microwave oven has cooled down before cleaning it.

**CAUTION:** Remove the glass tray from the oven when cleaning the oven or tray. To prevent the tray from breaking, handle it with care and do not put it in water immediately after cooking. Wash the tray carefully in warm sudsy water or in the dishwasher.

### **Cleaning the turntable and roller rings**

Clean the roller rings periodically and wash the turntable as required. The turntable can be washed safely in your dishwasher.

### **Storing and repairing your microwave oven**

If you need to store your microwave oven for a short or extended period of time, choose a dust-free, dry location. Dust and dampness may adversely affect the functionality of the microwave parts.

**WARNING:** Do not repair, replace, or service any part of your microwave oven yourself. Allow only a qualified service technician to perform repairs. If the oven is faulty and needs servicing, or you are in doubt about its condition, unplug the oven from the power outlet and contact your nearest service center. Do not use the oven if the microwave oven is damaged, in particular, if the door or door seals are damaged or the door does not close properly. This can be caused by a broken hinge, a worn out seal or distorted/bent casing. Do not remove the oven from its casing. This microwave oven is for home use only and is not intended for commercial use

### **Replacing the cooktop/night light**

When replacing the cooktop/night light, make sure that you are wearing gloves to avoid injury from the heat of the lamp.



1. Unplug the oven or turn off the power at the main power supply.
2. Remove the screw from the light cover and lower the cover.
3. Disconnect the wire connectors.
4. Remove the screw securing the LED lamp board.
5. Replace the LED lamp board.

### **Replacing the oven light**

When replacing the oven light, make sure that you are wearing gloves to avoid injury from the heat of the lamp.



1. Unplug the oven or turn off the power at the main power supply.
2. Remove the vent cover mounting screw and then remove the vent cover.
3. Lift up the holder lamp by pushing the hook slightly.
4. Remove the lamp from the holder lamp and disconnect the wire connectors. 5. Replace the LED lamp.
6. Connect wire to LED lamp and place it on the holder lamp.
7. Insert holder lamp to the bracket, assemble vent cover and then mount the screw.
8. Plug the oven in or turn on the power at the main power supply. Reset the clock.

### **Cleaning the grease filter**

Your microwave oven has reusable grease filter. The grease filter should be removed and cleaned at least once a month or as required.

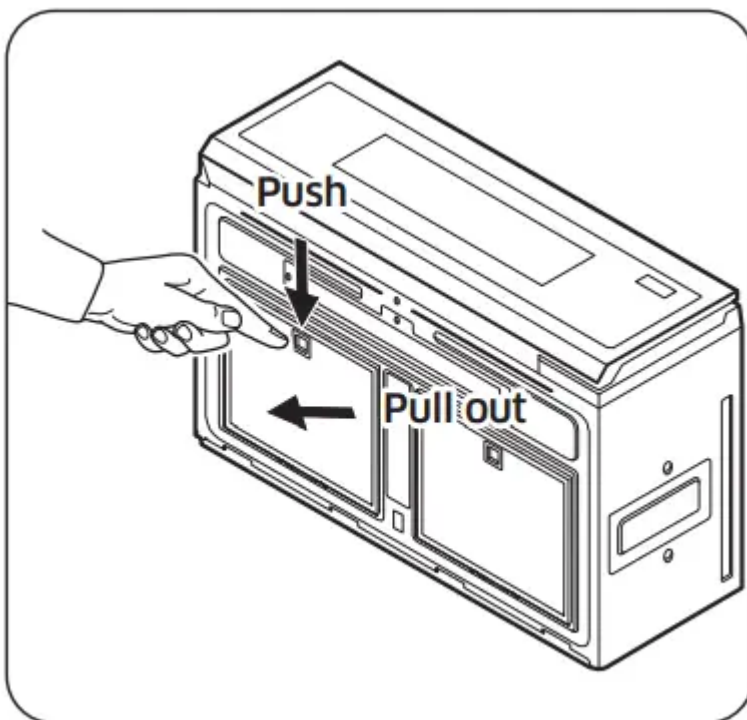

1. To remove the filter, push the handle of the grease filter.
2. Pull the grease filter out of the microwave oven.



3. Soak the grease filter in hot water mixed with a mild detergent. Rinse well and shake to dry. If necessary, brush the filter lightly to remove embedded dirt.

**WARNING:** Do not use ammonia or put the grease filter in the microwave oven to dry. The aluminum will darken.



4. To re-insert the filter into the microwave oven, slide the filter into the frame slot, and then push it inside.

### Replacing the charcoal filter

The charcoal filter should be replaced every 6 to 12 months and more often if necessary. The charcoal filter cannot be cleaned.

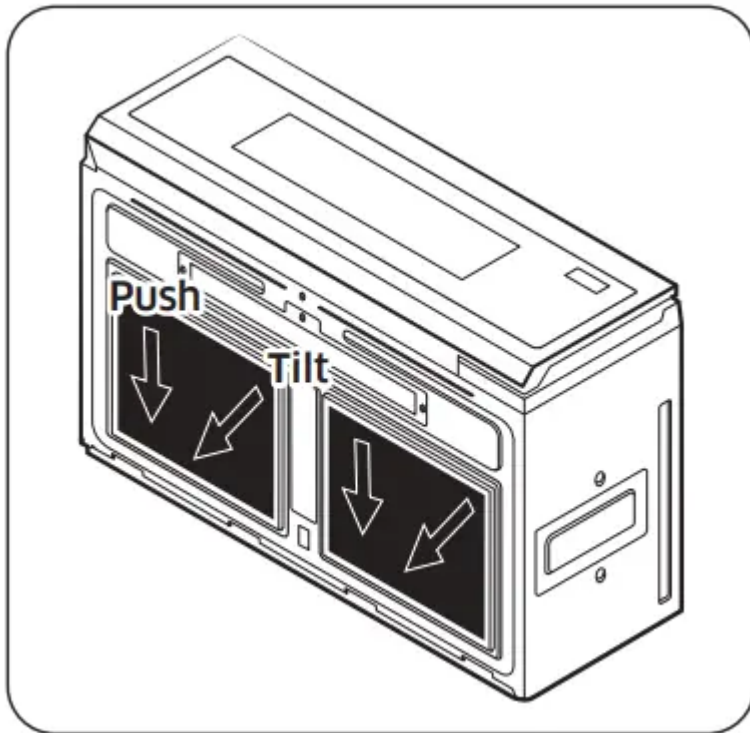

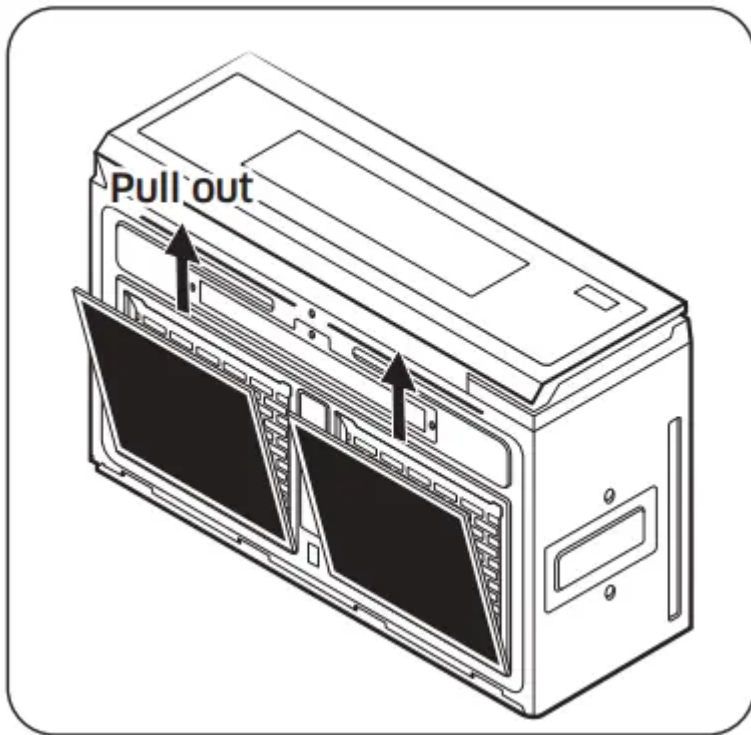

1. Unplug the oven or turn off the power at the main power supply.
2. Remove the grease filter. (Check the instructions on '**Cleaning the grease filter**')
3. Push down the charcoal filter and then tilt it forward.
4. Pull the filter up to remove it.
5. Slide a new charcoal filter into place. Proceed opposite order from above instructions.
6. Insert grease filter. Plug the oven in or turn on the power at the main power supply. Reset the clock

## Troubleshooting

### Check points

If you encounter a problem with your oven, first check the tables starting below and try the recommendations. If a problem persists, or if an information code keeps appearing on the display, contact a local Samsung service center.

<b>Problem</b>	<b>Cause</b>	<b>Action</b>
<b>General</b>		
The buttons cannot be touched properly	Foreign matter may be caught between the buttons.	Remove the foreign matter and try again.
	For touch models: Moisture is on the exterior.	Wipe the moisture from the exterior.
	The Child Lock is activated.	Deactivate the Child Lock
The time is not displayed.	Power is not supplied.	Make sure power is supplied. Confirm the microwave is plugged in. Check your fuses or circuit breakers.
	The Eco (power-saving) function is set.	Turn off the Eco function.
The oven does not work	Power is not supplied.	Make sure power is supplied. Confirm the microwave is plugged in. Check your fuses or circuit breakers.
	The door is open.	Close the door and try again.
	The door open safety mechanisms are covered by foreign matter.	Remove the foreign matter and try again.
The oven stops while in operation.	The user has opened the door to turn food over.	After turning over the food, touch the START button again to start operation.
The power turns off during operation.	The oven has been cooking for an extended period of time	After the oven has cooked for an extended period of time, let the oven cool.
	The cooling fan is not working.	Listen for the sound of the cooling fan.
	Trying to operate the oven without food inside	Put food in the oven.

	There is not enough ventilation space around the oven.	There are intake/exhaust outlets on the front and rear of the oven for ventilation. Check the installation guide and make sure that the microwave is far enough away from walls and cabinets for proper ventilation.
	Several appliances or devices are plugged into the same outlet.	Unplug all other appliances or devices from the outlet
There is no power to the oven.	Power is not supplied.	Make sure power is supplied. Confirm the microwave is plugged in. Check your fuses or circuit breakers.
There is a popping sound during operation, and the oven doesn't work.	Cooking food in a sealed container or using a container with a tight lid	Do not cook food in sealed containers or in containers with tight lids. Expanding steam from the cooking food can cause the containers to burst or the lids to pop off.
The oven exterior gets too hot during operation.	There is not enough ventilation space around the oven.	There are intake/exhaust outlets on the front and rear of the oven for ventilation. Check the installation guide and make sure that the microwave is far enough away from walls and cabinets for proper ventilation.
	Objects are on top of the oven.	Remove all objects on the top of the oven.
The door cannot be opened properly	Food residue is stuck between the door and oven interior.	Clean the oven and then open the door.
The oven does not heat.	The oven may not work if too much food is being cooked or improper cookware is being used.	To test the oven, put one cup of water in a microwave-safe container, put the container in the oven, and then run the microwave for 1-2 minutes to check whether the water is heated. If the water is heated, reduce the amount of food and start the function again. Use a cooking container with a flat bottom.
Heating is weak or slow.	The oven may not work if too much food is being cooked or improper cookware is being used.	To test the oven, put one cup of water in a microwave-safe container, put the container in the oven, and then run the microwave for 1-2 minutes to check whether the water is heated.

		If the water is heated, reduce the amount of food and start the function again. Use a cooking container with a flat bottom.
The warm function does not work.	The oven may not work if too much food is being warmed or improper cookware is being used.	To test the oven, put one cup of water in a microwave-safe container, put the container in the oven, and then run the microwave for 1-2 minutes to check whether the water is heated. If the water is heated, reduce the amount of food and start the function again. Use a cooking container with a flat bottom.
The thaw function does not work.	The oven may not work if too much food is being thawed or improper cookware is being used.	To test the oven, put one cup of water in a microwave-safe container, put the container in the oven, and then run the microwave for 1-2 minutes to check whether the water is heated. If the water is heated, reduce the amount of food and start the function again. Use a cooking container with a flat bottom.
The interior light is dim or does not turn on	The door has been left open for a long time.	The interior light may automatically turn off when the Eco function operates. Close and reopen the door or touch the STOP button.
	The interior light is covered by foreign matter.	Clean the inside of the oven and check again.
A beeping sound occurs during cooking.	If the Auto Cook function is being used, this beeping sound means it's time to turn over the food.	After turning over the food, touch the START button again to restart operation.
The oven is not level.	The oven is installed on an uneven surface.	Make sure the oven is installed on flat, stable surface.
There are sparks during cooking.	Metal containers are used during cooking or thawing.	Do not use metal containers.
When power is connected, the oven immediately starts to work.	The door is not properly closed.	Close the door and check again.

There is electricity coming from the oven.	The power source or power outlet is not properly grounded.	Make sure the power source and power outlet are properly grounded.
There is water dripping.	Water or steam may be generated by the cooking or defrosting process, depending on the food. This is not an oven malfunction.	Let the oven cool and then wipe with a dry dish towel.
There is steam coming through a crack in the door	Water or steam may be generated by the cooking or defrosting process, depending on the food. This is not an oven malfunction.	Let the oven cool and then wipe with a dry dish towel.
There is water left in the oven.	Water or steam may be generated by the cooking or defrosting process, depending on the food. This is not an oven malfunction	Let the oven cool and then wipe with a dry dish towel.
The brightness inside the oven varies.	Changes in brightness reflect changes in power output. Power output changes depending on the functions in use.	Power output changes during cooking are not malfunctions.
Cooking is finished, but the cooling fan is still running.	To ventilate the oven, the cooling fan continues to run for about 3 minutes after cooking is complete.	This is not an oven malfunction.
Touching the START button operates the oven.	This happens when the oven is not operating.	The microwave oven is designed to start operating when you touch the START button if it was not operating.
<b>Turntable</b>		

While turning, the turntable comes out of place or stops turning.	There is no roller ring, or the roller ring is not properly in place.	Install the roller ring properly and then try again.
The turn table drags while turning.	The roller ring is not properly in place, there is too much food, or the container is too large and touches the inside of the microwave.	Install the roller ring properly. Adjust the amount of food. Do not use containers that are too large.
The turn table rattles while turning and is noisy	Food residue is stuck to the bottom of the oven.	Remove any food residue stuck to the bottom of the oven.

### Information codes

If the microwave oven fails to operate, you may see an information code on the display. Check the table below for the code, and then follow the directions.

<b>Code</b>	<b>Description</b>	<b>Action</b>
<b>C-10</b>	The GAS sensor is open	Unplug the power cord of the oven, and then contact a local Samsung service center.
	The GAS sensor is shorted.	
<b>C-F0</b>	The microwave has sensed an internal communications failure.	Unplug the power cord of the oven, and then contact a local Samsung service center.
<b>C-F1</b>	Only occurs when EEPROM Read or Write is not working.	Unplug the power cord of the oven, and contact a local SAMSUNG Customer Care Center.
<b>C-F2</b>	A touch button has malfunctioned.	Touch STOP, and then try the button again
<b>C-d0</b>	Control buttons are touched over 10 seconds.	Clean the keys and check if there is water on the surface around key. If it appears again, turn off the microwave oven, let it sit for more than 30 seconds, and then try setting again. If this code re-appears, call your local SAMSUNG Customer Care Center.

## Specifications

Model	ME11A7710D*/AA ME11A7510D*/AA	ME11A7710D*/AC ME11A7510D*/AC
Oven Cavity	1.1 cu ft	
Controls	10 power level, including Defrost	
Timer	99 minutes, 99 seconds	
Power Source	120 VAC, 60 Hz	
Power Consumption	1650 Watt Microwave	1500 Watt Microwave
Microwave Power Output	1100 Watts	1000 Watts
Cook Top Light	LED lamp (3 EA)	
Oven Light	LED lamp	
Oven Cavity Dimensions (inches)	18 ½" (W) X 6 ⅙" (H) X 14 ⅙" (D)	
Outside Dimensions (inches)	29 ⅞" (W) X 10 ¾" (H) X 19 ⅛" (D)	
Shipping Dimensions (inches)	33 ¼" (W) X 15 ⅞" (H) X 22 ⅛" (D)	
Net/Shipping Weight	ME11A7710D*: 55.8 lbs. / 65.3 lbs. (25.3 kg / 29.6 kg) ME11A7510D*: 53.6 lbs. / 63.1 lbs. (24.3 kg / 28.6 kg)	

### Warning

This content is compiled from multiple sources and is provided for reference purposes only. It may not be complete or fully applicable to all situations. If you are unable to resolve your issue, please contact the product manufacturer or an authorized service provider for official support.

