

VACUUM ASSEMBLY

CARTON CONTENTS

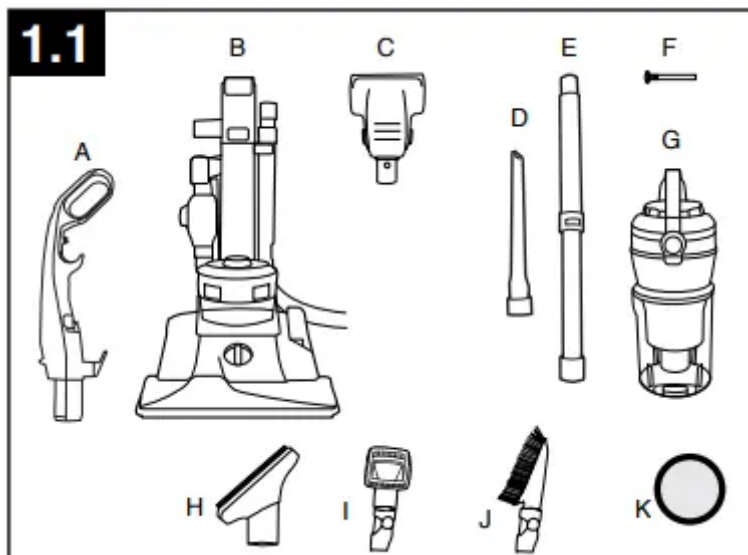

- A. Handle
- B. Vacuum Base
- C. Pet Turbo Tool/Turbo Tool*
- D. Crevice Tool
- E. Telescoping Wand
- F. Screw (for assembly)
- G. Dirt Cup
- H. Pet Upholstery Tool*
- I. Articulating Upholstry Tool*
- J. Articulating Dusting Tool*
- K. Extra Filter* *Varies per model

Remove all parts from carton and identify each item shown.

Make sure all parts are located before disposing of packing materials.

Additional parts may be ordered at Hoover.com or call 1-800-944-9200

ATTACH HANDLE

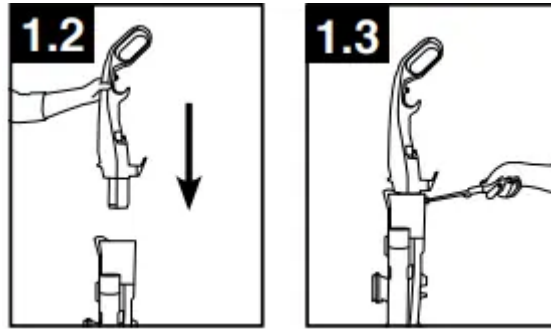

- Note: Remove the screw located in the vacuum base and set aside until instruction 1.3
- 1.2 Insert handle section into vacuum base. Push down firmly.
- 1.3 Using a Phillips screwdriver, fasten (1) screw behind handle into vacuum base.

ATTACH DIRT CUP

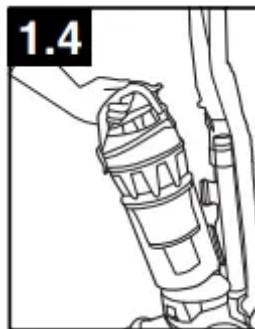

- 1.4 Place bottom of dirt cup into vacuum body first. Pivot cup into vacuum. Dirt cup is secure when you hear a click.

POSITION TOOLS (varies per model)

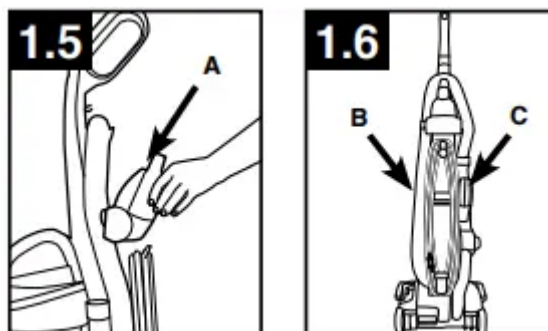

- 1.5 Attach bottom of Turbo Tool (A) and pivot into Air powered Tool Clip until secure.
- 1.6 Place Crevice Tool into Wand and slide into tool storage area on left back side (B) of vacuum and place Upholstery Tool or Articulating Tool on right back side (C) of vacuum as shown.

HOW TO USE

VACUUM DESCRIPTION

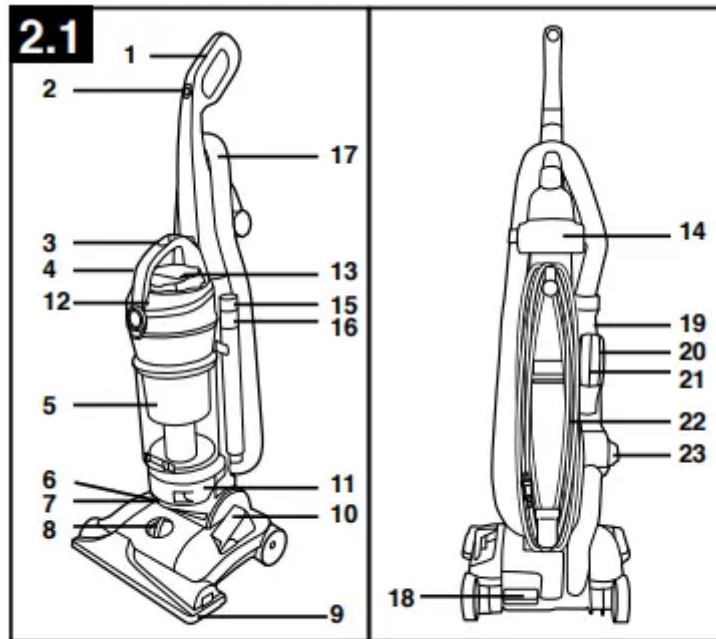

*Available on select models only

**Varies per model

1. Handle
2. ON/OFF Switch
3. Dirt Cup Release Button
4. Carry Handle
5. Dirt Cup
6. Stair Cleaning Handle
7. Headlight*
8. Height Adjustment
9. Furniture Guard
10. Brushroll On/Off Pedal (Suction Only Mode)
11. Filter made with HEPA media and Carbon Filter* Access
12. Rinsable Filter Access
13. System Check Indicator
14. Turbo Tool **
15. Crevice Tool (inside wand)
16. Telescoping Wand

17. Hose
18. Handle Release Pedal
19. Hose Tube
20. Hose Release Button
21. Dusting/ Upholstery Tool**
22. Cord
23. Air Valve Dial

ON-OFF SWITCH

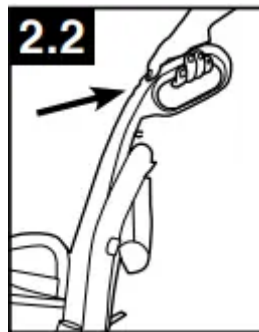

- 2.2 Plug cord into electrical outlet.
- To turn vacuum ON, push ON/OFF switch once.
- To turn vacuum OFF, push switch again.

SUCTION ONLY MODE/ BRUSHROLL SHUT-OFF

for bare floors and very high pile carpet

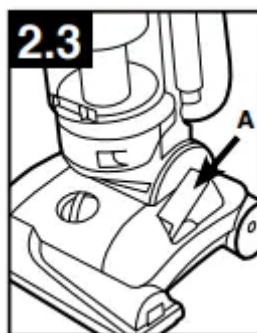

- 2.3 For optimal cleaning performance on bare floors and carpet with pile deeper than 1", brushroll should be turned off.
- The vacuum is shipped with the brushroll in the ON position. To turn brushroll OFF for Suction Only Mode, step on pedal (A).

IMPORTANT: Pedal (A) is inactive when the cleaner is in the upright position.

CAUTION: Brushroll should be in off position for cleaning of high pile carpet deeper than 1”.

CAUTION: Not to be used for grooming a pet.

TRANSPORTING CLEANER



- 2.6 To move your cleaner from room to room, put handle in upright position, tilt cleaner back on rear wheels and push forward.

HANDLE POSITIONS

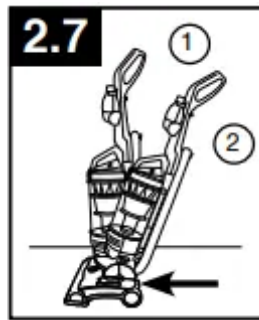

- 2.7 The handle of your cleaner has two positions:
 1. Upright for storage and when using cleaning tools.
 2. Operating position for general operation on carpets and floors.
- Step on handle release pedal to lower handle.

CARPET HEIGHT ADJUSTMENT

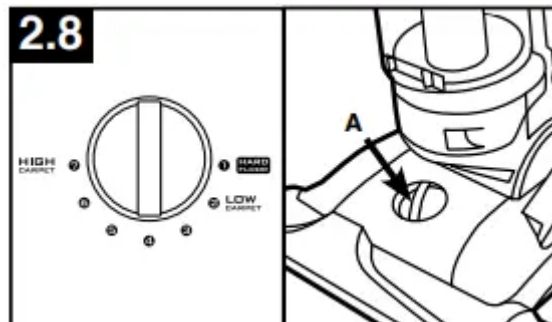

- 2.8 To adjust height setting, TURN knob (A) to desired height setting.

- For maximum cleaning performance, the following carpet height settings are recommended:
 - Barefloor setting (1): for bare floors.
 - Low setting (2): for all types of carpet.
 - Higher settings: for very deep pile carpet, where easier pushing effort is desired, while maintaining good cleaning performance.

IMPORTANT: If the vacuum is difficult to push turn knob to the next higher setting.

AIR VALVE DIAL

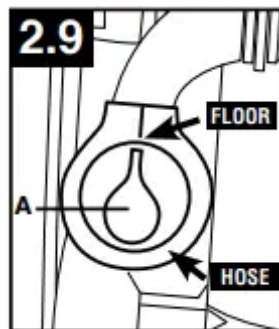

- 2.9 To operate dial, TURN dial (A) to desired position until it clicks. HOSE position is for cleaning with hose and/or tools. FLOOR position is for general floor cleaning thru nozzle.
- IMPORTANT: Vacuum will only pick up debris by the Hose/ Tools when the valve dial is placed into “HOSE” position. Valve dial must be returned to “FLOOR” position in order to pick up debris thru the floor Nozzle.

TOOLS

- Tools allow for cleaning surfaces above the floor and for reaching hard to clean areas.
- The vacuum is ready for tool use when handle is in upright position.

SELECT PROPER TOOL

(Tools may vary per model)

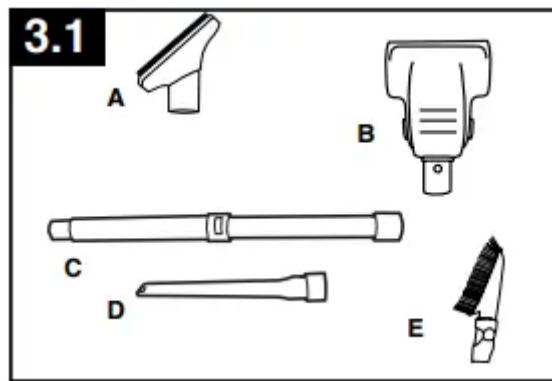

- A. Use Upholstery Tool to clean upholstered furniture and carpeted stairs.
- B. Turbo Tool may be used for upholstered furniture, and carpeted stairs.
- C. Telescoping Wand is used to give extra length to your hose.
- D. Crevice Tool may be used in tight spaces, corners and along edges.
- E. Articulating Tool may be used to clean hard to reach areas such as ceiling fans and bookshelves.

REMOVING HOSE

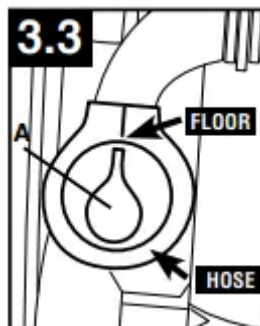
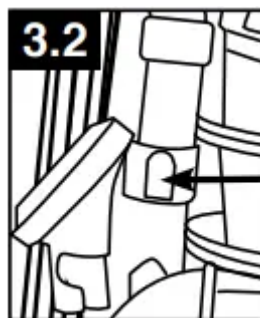

- 3.2 When using cleaning tools, place cleaner handle in the upright position. The agitator brushroll will not rotate when the cleaner is in the upright position.
- To remove hose for tool use, press the hose release button and pull hose end out.
- To lock back into place, push hose into hose tube until you hear a click.
- 3.3 Set air valve for desired use. Hose Floor. Turn valve back counterclockwise to FLOOR position until it clicks (A).

IMPORTANT: Vacuum will only pick up debris by the Hose/ Tools when the valve dial is placed into “HOSE” position. Valve dial must be returned to “FLOOR” position in order to pick up debris thru the floor Nozzle.

ATTACH WAND AND TOOLS (Tools may vary per model)

WARNING: Unplug before connecting Air-Powered Hand Tool.

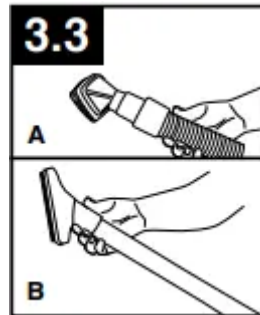

- 3.3 Attach tool or wand to the hose (A).
- Attach tool to wand (B) by pushing it firmly onto the wand.
- Twist wand or tool slightly to tighten or loosen the connection.
- To extend wand, twist counter-clockwise to the unlocked position, extend wand & twist clockwise until tight. Reverse to collapse.

CAUTION: Not to be used for grooming a pet.

HOW TO CLEAN TOOLS

- To clean Hose and Turbo Tool, wipe with a damp cloth. DO NOT submerge in water.
- Other cleaning tools may be washed in warm water with a mild detergent. Rinse and air dry 24 hours before using.

STAIR CLEANING

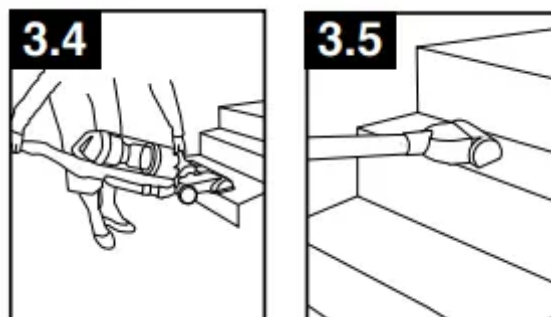

- 3.4 Lift vacuum by Stair Cleaning Handle and position on stairs. Clean forward to back. Never leave the vacuum standing on stairs when not cleaning.

- 3.5 Use the Hose and Turbo Tool (Tool varies per model) for stair cleaning. When using tools, always ensure handle is in upright position.

CAUTION: Use extra care when cleaning on stairs. To avoid personal injury or damage, and to prevent the cleaner from falling, always place cleaner at bottom of stairs on floor. Do not place cleaner on stairs or furniture, as it may result in injury or damage. When using tools, always ensure handle is in upright position.

CORD STORAGE

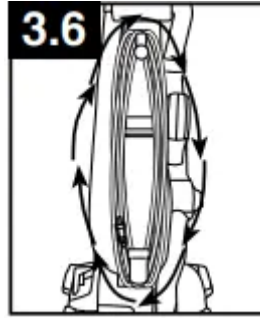

- 3.6 Wrap cord around hooks for convenient storage. Attach the plug end to the cord.

MAINTENANCE

- Familiarize yourself with these home maintenance tasks as proper use and care of your vacuum will ensure continued cleaning effectiveness.
- If appliance is not working as it should, has been dropped, damaged, left outdoors, or dropped into water, take it to a service center prior to continuing use.
- 4.1 The System Check Indicator located at (A), alerts you to possible system performance issues.

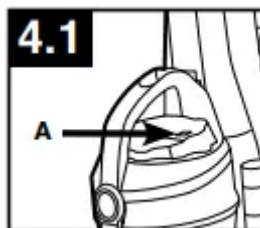

PROBLEM	POSSIBLE CAUSE	POSSIBLE SOLUTION
If System Check Indicator is red:	<ol style="list-style-type: none"> 1. Rinsable filter and/or filter made with HEPA media is dirty. 2. Dirt cup is full and/or clogged. 3. Brushroll and/or hose is clogged. 4. Valve dial may be partially turned and not in proper mode. 	<ol style="list-style-type: none"> 1. Clean rinsable filter and/or filter made with HEPA media - reference pg. 11 2. Empty dirt cup - reference pg. 11 3. Check hose for clogging - reference pg 13. Check brushroll for clogging - reference pg. 12. 4. Turn valve dial to HOSE or FLOOR mode. – reference pg. 7

Any other servicing should be done by an authorized service representative.

NOTICE

- A Thermal Protector has been designed into your cleaner to protect it from overheating. When the thermal protector activates the cleaner will stop running.
- If this happens proceed as follows:
 1. Turn cleaner OFF and unplug it from the electrical outlet.
 2. Empty dirt cup.
 3. Inspect the nozzle inlet, hose connector, hose, dirt cup inlet, cyclonic filter, rinsable filter, and HEPA filter for any obstructions. Clear obstructions if present.
- When cleaner is unplugged and motor has cooled for 30 minutes, the thermal protector will deactivate and cleaning may continue.
- If the thermal protector continues to activate after following the above steps, your cleaner needs servicing.

DIRT CUP

When to Empty

- 4.2 To maintain optimal performance, empty the dirt cup before the dirt cup reaches the max line (A). Place the vacuum in the upright position before removing the dirt cup.

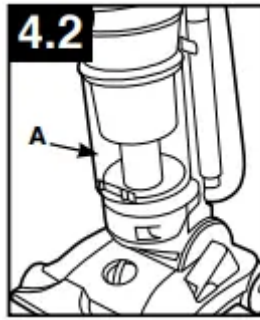

WARNING

- To reduce the risk of personal injury - Unplug before cleaning or servicing. Do not use vacuum without dirt cup or filters in place.
- Very fine materials, such as face powder or cornstarch, may seal the filter and cause a reduction in performance. When using the vacuum for this type of dust, empty the cup and clean the filters often.

How to Empty

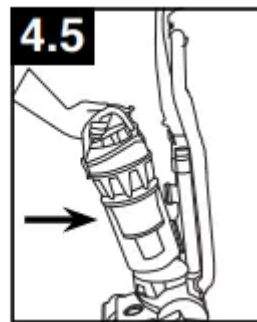
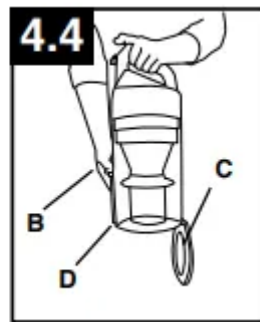
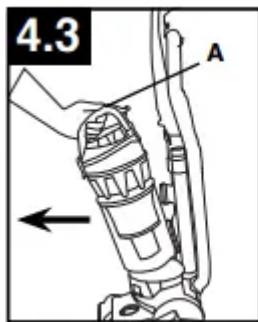

- 4.3 Press dirt cup release button (A) and pivot cup out.
- 4.4 Hold dirt cup over trash receptacle, push dirt cup door release lever (B) to open dirt cup door (C).
- Close dirt cup door (C). Press firmly to secure at front (D).
- 4.5 Place bottom of dirt cup into vacuum body first. Pivot dirt cup into vacuum body and press firmly until it locks into place.

FILTERS: When to Clean

- To maintain optimal performance, filters should be cleaned at least every two months under normal use

Rinsable Filter: How to Clean

- Remove dirt cup as described in Fig. 4.3.
- 4.6 Pull up on dirt cup latch to open.

- 4.7 Pull on filter by the pocket to remove rinsable filter. Hold filter under running water for at least two minutes to remove dirt and debris. Squeeze filter twice while underwater. Remove from water and squeeze a final time to remove excess water.
- **IMPORTANT:** Allow filter to dry completely before replacing. Dry filter on edge so air circulates on both sides of filter. This may take up to 48 hours.
- Replace filter with pocket and graphics facing up.
- Close lid securely by pushing until it clicks.
- Replace dirt cup as described in Fig 4.5.

WARNING: To reduce the risk of personal injury - Unplug before cleaning or servicing. Do not use vacuum without dirt cup or filters in place.

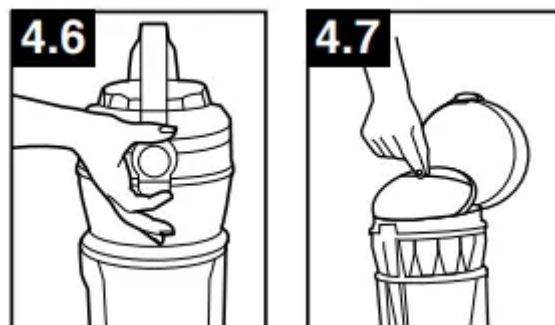

What to Buy: Rinsable Filter

- When used and maintained properly, your Rinsable Filter should not need replacement within the warranty period. If desired, additional filter is available at Hoover.com or call 1-800-944-9200. Ask for Hoover® Part No. 304087001

Filter Made With HEPA Media: How to Clean

- 4.8 With fingers in slots, pull filter frame (A) straight out. Hold filter over a trash receptacle and tap out dirt and debris.
- Slide back into position on vacuum.
- **WARNING:** To reduce the risk of personal injury - Unplug before cleaning or servicing. Do not use vacuum without dirt cup or filters in place.

IMPORTANT: DO NOT RINSE OR WASH THE FILTER MADE WITH HEPA MEDIA.

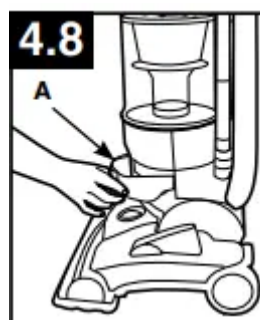

What to Buy: Filter Made With HEPA Media When used and maintained properly, your Filter should not need replacement within the warranty period. If desired, additional filter is available at Hoover.com or call 1-800-944-9200. Ask for Hoover® Part No. 305687001.

Carbon Filter : How to Clean - (Available on select models only).

- Your Carbon Filter is located on the underside of the Filter made with HEPA media.
- IMPORTANT: DO NOT RINSE OR WASH the Carbon Filter.
- What to Buy: Carbon Filter Carbon Filter may need to be replaced more often to maintain optimal odor absorbing effectiveness. Additional filter is available at Hoover.com or call 1-800-944-9200. Ask for Hoover® Part 902404001.

Cyclonic Filter Assembly: How to Clean

- WARNING: To reduce the risk of personal injury - Unplug before cleaning or servicing. Do not use vacuum without dirt cup or filters in place.
- Remove dirt cup as described in Fig. 4.3.
- 4.9 Twist filter assembly (A) counter-clockwise. Remove assembly from dirt cup.
- 4.10 Dirt and debris can be cleaned from the filter assembly with the Dusting/ Upholstery Tool.
- 4.11 If further cleaning of the internal filter assembly is required, turn dust skirt (B) counterclockwise to remove.
- 4.12 Grab dirt cup shroud (C), pull straight off and clean with dusting/upholstery tool.
- After cleaning, replace dirt cup shroud (C) onto inside edge of filter assembly and align. Place skirt (B) onto shroud, align (4) slots with (4) tabs, and turn clockwise to lock.
- Place the filter assembly (4.9, A) on the dirt cup, aligning (3) tabs on filter with (3) slots on dirt cup (B) and twist it clockwise to secure into position



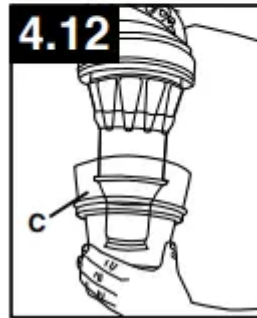
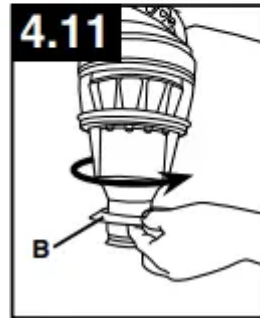
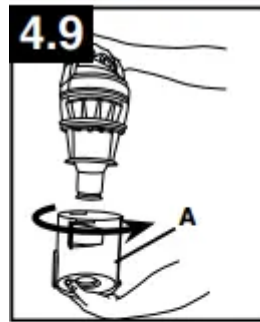

- Replace dirt cup as described in Fig. 4.5.

BRUSHROLL: How to Clean

CAUTION: To reduce the risk of injury from moving parts - Unplug before servicing.

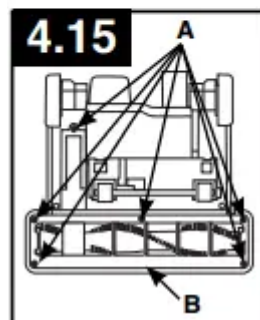
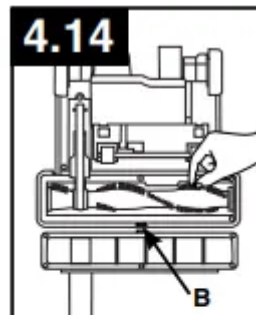
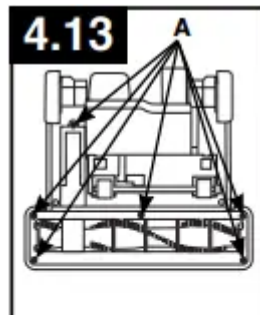

- 4.13 Turn vacuum over so bottom side is facing up and remove the (6) screws (A).
- 4.14 Pivot out bottom plate away from hidden latch (B) and remove any debris and/or hair from the brushroll.
- 4.15 Reposition bottom plate, aligning latch (B) and fastening all (6) screws (A). Press firmly at latch (B) area to ensure that it is properly latched.

HOSE: How to Clean

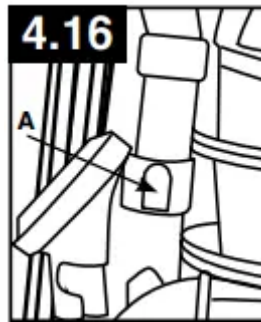

- **WARNING:** To reduce the risk of personal injury - Unplug before cleaning or servicing.
- 4.16 To remove hose for tool use, press the hose release button (A) and pull hose end out.
- Clear away debris or obstructions from hose. Do not use sharp objects to clean out hose as they can cause damage. To lock back into place, push hose into hose tube until you hear a click.

TURBO TOOL: How to Clean

(Tool varies per model)

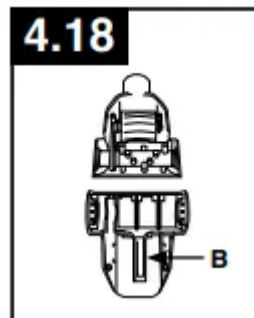
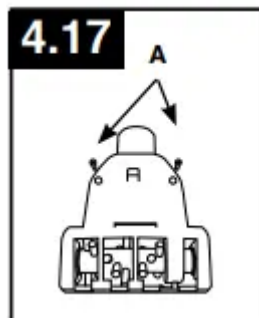

CAUTION ! To reduce the risk of injury from moving parts - Unplug vacuum before servicing

- 4.17 Clean the Turbo Tool by removing the two screws (A), located on the bottom cover, with a Phillips head screwdriver.
- 4.18 Remove the bottom cover (B). Clean out any debris or hair from the brushroll and turbine fan.
- 4.19 Replace the bottom cover, insert and tighten the (2) screws.

HEADLIGHT: How to Replace (available on select models only)

WARNING: To reduce the risk of electric shock - Unplug before cleaning or servicing.

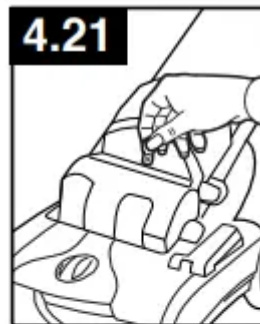

What to Buy: Headlight

Additional bulbs may be ordered at Hoover.com or call 1-800-944-9200. Ask for Hoover® Part No. 27313-107.



Removing Lens

- Press Handle Release Pedal and place handle in low position.
- 4.20 Using a Phillips screwdriver, remove (2) screws as shown and lift off lens.

Installing Bulb

- 4.21 Pull old bulb straight out of socket. Push new bulb straight into socket until locked in place.
- Do not use excessive force when installing bulb.
- Do not twist or turn bulb when installing bulb.

Replacing Lens

- 4.22 Reposition lens and secure with screws.

BELT

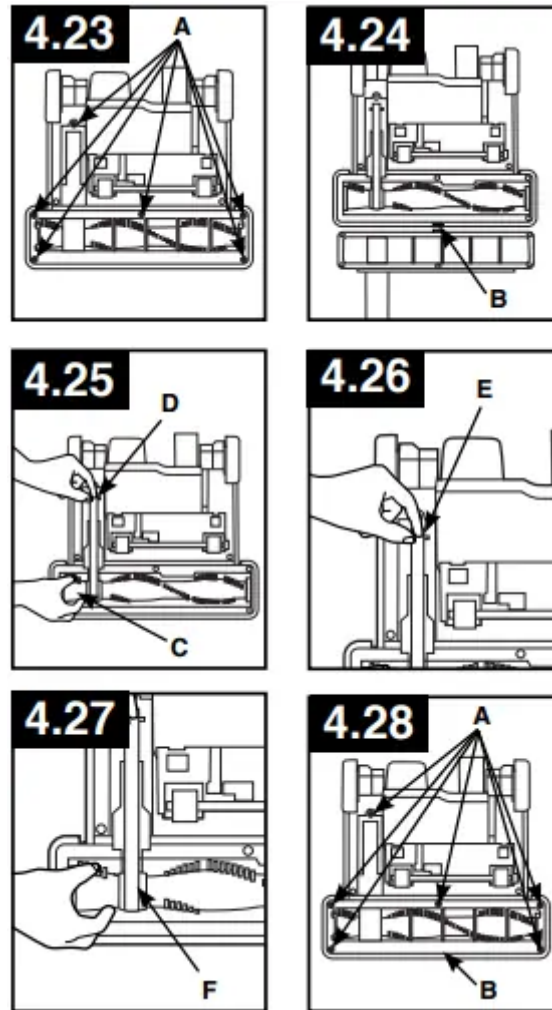

- CAUTION: To reduce the risk of injury from moving parts - Unplug before servicing.
- The belt is located under the bottom plate of the vacuum and should be checked from time to time to be sure it is in good condition.
- When To Replace: Replace belt if it is stretched, cut or broken. To check the belt, refer to Fig. 4.26 - 4.28.
- How To Replace
 - 4.23 Turn vacuum over so bottom side is facing up and remove the (6) screws (A).
 - 4.24 Pivot out bottom plate away from hidden latch (B).
 - 4.25 Remove used belt from brushroll (C) then from motor shaft (metal rod) (D) and discard.

What to Buy: Belt Use only genuine HOOVER® belts with your vacuum. When purchasing a new belt for models with Brushroll On/Off (Suction Only Mode), ask for Flat Belt - HOOVER® part No.

562289001 or AH20065. If desired, additional belts can be purchased at Hoover.com or 1-800-944-9200

- 4.26 With lettering on outside of belt, slide new belt over motor shaft (metal rod) (E).
- 4.27 Remove any debris and/or hair from the brushroll. Then slip other end of belt around area of brushroll without bristles (F). With belt in place, pull and slide brushroll into nozzle making sure that the brushroll end caps are in the correct orientation.
- 4.28 Reposition bottom plate, aligning latch (B) and fastening all (6) screws (A). Press firmly at latch (B) area to ensure that it is properly latched

LUBRICATION: The motor and brushroll are equipped with bearings which contain sufficient lubrication for their lifetime. The addition of lubricant could cause damage. Do not add lubricant to motor or brushroll.

TROUBLESHOOTING

- If a minor problem occurs, it usually can be solved quite easily when the cause is found by using the checklist below.
- Any other servicing should be done by an authorized service representative. If appliance is not working as it should, has been dropped, damaged, left outdoors, or dropped into water, take it to a service center prior to continuing use.

WARNING: To reduce the risk of personal injury - Unplug before cleaning or servicing.

PROBLEM	POSSIBLE CAUSE	POSSIBLE SOLUTION
Vacuum won't run	<ol style="list-style-type: none"> 1. Power cord not firmly plugged into outlet. 2. Blown fuse or tripped breaker 3. Thermal Protector activated. 	<ol style="list-style-type: none"> 1. Plug unit in firmly. 2. Check fuse or breaker in home. Replace fuse/reset breaker in home. 3. Unplug and allow vacuum to cool for 30min.(This will reset the thermal protector)
System Check Indicator has turned red or Vacuum won't pick up or Low suction	<ol style="list-style-type: none"> 1.Rinsable Filter and/ or Filter made with HEPA media is dirty 2. Dirt cup full and/ or clogged. 3. Broken or worn belt. 4. Brushroll and/ or Hose clogged 5. Carpet height setting is incorrect. 6. Suction Only Mode is ON. 7. Valve dial may be partially turned and/or not in proper mode. 	<ol style="list-style-type: none"> 1. Clean Rinsable Filter and or Filter made with HEPA media - Pg. 11. 2. Empty dirt cup - Pg. 10. 3. Replace belt - Pg.14. 4. Check Hose - Pg. 13. Check Brushroll - Pg. 12. 5. Set Carpet Height Adjustment to appropriate setting for carpet being cleaned - Pg.7 6. Step on Brushroll ON/OFF Pedal to turn Suction Only Mode OFF - Pg. 6. 7. Turn valve dial to FLOOR or HOSE mode. – Pg. 7
Dust escaping from vacuum	<ol style="list-style-type: none"> 1. Dirt cup full. 2. Dirt cup not installed correctly 3. Hose not installed correctly. 4. Rinsable and/ or Filter made with HEPA media not installed completely 	<ol style="list-style-type: none"> 1. Empty dirt cup - Pg. 10. 2. Review Dirt Cup removal & replacement - Pg. 11. 3. Review Hose installation - Pg. 8. 4. Review Filter Removal and Cleaning - Pg. 11.
Headlight not working	<ol style="list-style-type: none"> 1. Bulb burnt out. 	<ol style="list-style-type: none"> 1. Replace bulb - Pg. 13.



	2. Loose electrical wires.	2. Call 1-800-944-9200 for nearest authorized Hoover® dealer.
Vacuum is difficult to push or won't move forward	<ol style="list-style-type: none"> 1. Carpet height setting is incorrect. 2. Brushroll is activated. 	<ol style="list-style-type: none"> 1a. Set Carpet Height Adjustment knob to appropriate setting for carpet being cleaned - Pg. 7. 2. For very high pile carpet deeper than 1", turn brushroll off.
Turbo Tool brushroll won't turn	<ol style="list-style-type: none"> 1. Too much pressure being applied to tool. 2. Blockage. 3. Low vacuum suction. 4. Valve dial may be partially turned and/or not in proper mode. 	<ol style="list-style-type: none"> 1. Continue using tool applying light pressure. 2. Remove blockage 3. Check items under "Vacuum won't pick up or Low suction." 4. Turn valve dial to FLOOR or HOSE mode. – Pg. 7
Smoky/burning smell detected	<ol style="list-style-type: none"> 1. Belt broken or stretched 2. Brushroll is clogged. 	<ol style="list-style-type: none"> 1. Replace brushroll belt - Pg. 14. 2. Clear/ remove debris from brushroll - Pg. 12.

Warning

This content is compiled from multiple sources and is provided for reference purposes only. It may not be complete or fully applicable to all situations. If you are unable to resolve your issue, please contact the product manufacturer or an authorized service provider for official support.

