

IMPORTANT SAFEGUARDS

When using electrical appliances, basic safety precautions should always be followed, including the following:

1. Read all instructions before using.
2. Do not touch hot surfaces. Use handles or knobs.
3. To protect against electric shock, do not immerse cord, plugs or fryer in water or other liquid.
4. Close supervision is necessary when any appliance is used by or near children.
5. Unplug from outlet when not in use and before cleaning. Allow to cool before putting on or taking off parts.
6. Do not operate any appliance with a damaged cord or plug or after the appliance malfunctions, or has been damaged in any manner. Return appliance to the nearest authorized service facility for examination, repair or adjustment.
7. The use of accessory attachments not recommended by the appliance manufacturer may cause injuries.
8. Do not use outdoors.
9. Do not let cord hang over edge of table or counter, or touch hot surfaces.
10. Do not place on or near a hot gas or electric burner, or in a heated oven.
11. Extreme caution must be used when moving appliance containing hot oil or other hot liquids.
12. Always attach plug to appliance first (depending on model), then plug cord into the wall outlet. To disconnect, turn any control to "off", then remove plug from wall outlet.
13. Do not use appliance for other than intended use.
14. SAVE THESE INSTRUCTIONS FOR HOUSEHOLD USE ONLY.
15. Only connect the appliance to electrical sockets which have a minimum load of 15A. If the sockets and the plug on the appliance should prove incompatible, get a professionally qualified technician to replace the socket with a more suitable one.

POLARIZATION INSTRUCTIONS

- This appliance has a polarized plug (one blade is wider than the other). To reduce the risk of electric shock this plug is intended to fit into a polarized outlet only one way. If the plug does not fit fully into the outlet, reverse the plug. If it still does not fit, contact a qualified electrician. Do not attempt to modify the plug in any way.

SHORT CORD INSTRUCTIONS

- Do not use with an extension cord.
- A short power-supply cord is to be provided to reduce the risk resulting from becoming entangled in or tripping over a longer cord.

SAFETY INSTRUCTION

- This appliance is intended to be used in household only. It is not intended to be used in the following applications, and the guarantee will not apply for:
 - staff kitchen areas in shops, offices and other working environments;
 - farm houses;
 - by clients in hotels, motels and other residential type environments;
 - bed and breakfast type environments.
- This appliance is not intended to be operated by means of an external timer or a separate remotecontrol system.
- If the power supply cord is damaged, it must be replaced by the manufacturer, its service agent or similarly qualified persons in order to avoid a hazard.
- This appliance is not intended for use by persons (including children) with reduced physical, sensory or mental capabilities, or lack of experience and knowledge, unless they have been given supervision or instruction concerning use of the appliance by a person responsible for their safety.
- Children should be supervised to ensure that they do not play with the appliance.
- The temperature of accessible surfaces may be high when the appliance is operating. Do not touch the hot surfaces of the appliance.
- Clean removable parts with a non abrasive sponge and dishwashing liquid or in a dishwasher (depending on model).
- Clean the inside and the outside of the appliance with a damp sponge or cloth. Please refer to the «Cleaning» section of the instructions for use.
- The appliance can be used up to an altitude of 4000 m.

Do

- Read and follow the instructions for use. Keep them safe.
- Remove all packaging materials and any promotional labels or stickers from your appliance before use. Be sure to also remove any materials from underneath the removable bowl (depending on model).
- Check that the voltage of your mains network corresponds to the voltage given on the rating plate on the appliance (alternative current).

- Given the diverse standards in effect, if the appliance is used in a country other than that in which it is purchased, have it checked by an approved Service Centre.
- Use the appliance on a flat, stable, heat-resistant work surface away from water splashes.
- Always unplug your appliance: after use, to move it, or to clean it.
- In the event of fire, unplug the appliance and smother the flames using a damp tea towel.
- To avoid damaging your appliance, please ensure that you follow recipes in the instructions and at www.t-fal.ca; make sure that you use the right amount of ingredients.

Do not

- Do not use the appliance if it or the power cord is damaged or if it has fallen and has visible damage or appears to be working abnormally. If this occurs, the appliance must be sent to an Approved Service Centre.
- Do not use an extension lead. If you nevertheless decide to do so, under your own responsibility, use an extension lead that is in good condition and compliant with the power of the appliance.
- Do not let the power cord dangle.
- Do not unplug the appliance by pulling on the power cord.
- Never move the appliance when it still contains hot food.
- Never operate your appliance when empty.
- Do not switch on the appliance near to flammable materials (blinds, curtains...). or close to an external heat source (gas stove, hot plate etc.).
- Do not store any inflammable products close to or underneath the furniture unit where the appliance is located.
- Never take the appliance apart yourself
- Do not immerse the product in water.
- Do not use any powerful cleaning products (notably soda based strippers), nor brillo pads, nor scourers.
- Do not store your appliance outside. Store it in a dry and well ventilated area

Advice/information

- When using the product for the first time, it may release a non-toxic odour. This will not affect use and will disappear rapidly.
- For your safety, this appliance conforms with applicable standards and regulations (Directives on Low Voltage, Electromagnetic Compatibility, Materials in contact with food, Environment, etc.).

- This appliance is designed for domestic use only and not outdoor. In case of professional use, inappropriate use or failure to comply with the instructions, the manufacturer accepts no responsibility and the guarantee does not apply.
- For your safety, only use the accessories and spare parts designed for your appliance

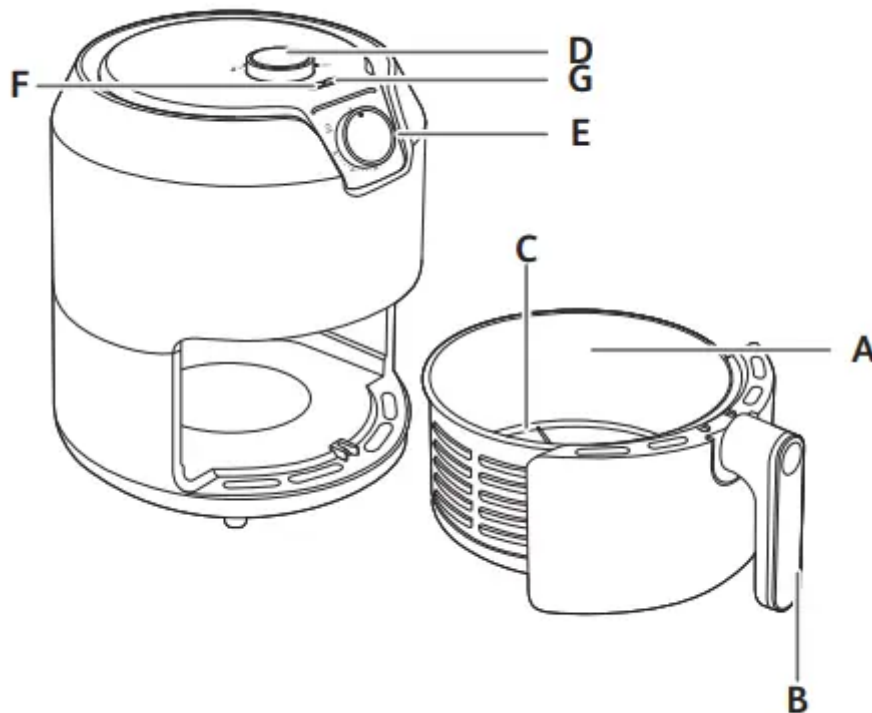

DESCRIPTION

- A. Bowl
- B. Bowl handle
- C. Removable grid
- D. Temperature control knob (80-200°C)
- E. Power on/off and timer (0-60 min) knob with auto shut-off
- F. Power indicator light
- G. Heating-up light

BEFORE FIRST USE

Online recipes at www.t-fal.ca help you get to know the appliance.

1. Remove all packaging material.
2. Remove any stickers or labels from the appliance.

3. Thoroughly clean the bowl and the removable grid with hot water, some washing-up liquid and a non-abrasive sponge. Note: You can also clean these parts in the dishwasher.
4. Wipe the inside and outside of the appliance with a damp cloth. Easy Fry works by producing hot air. Do not fill the bowl (A) with oil or frying fat.

PREPARING FOR USE

1. Place the appliance on a flat, stable, heat-resistant work surface away from water splashes.
2. Do not fill the bowl with oil or any other liquid. Do not put anything on top of the appliance. This disrupts the airflow and affects the hot air frying result.

USING THE APPLIANCE

Easy Fry can cook a large range of recipes. Cooking times for the main foods are given in the section 'Cooking Guide'.

1. Connect the power supply cord to an electrical socket.
2. Carefully pull the bowl out of the Easy Fry.
3. Place the food in the bowl. Note: Never fill the bowl beyond the MAX level mark or exceed the maximum amount indicated in the table (see into section 'Cooking Guide'), as this could affect the quality of the end result.
4. Slide the bowl back into the Easy Fry. Caution: Do not touch the bowl during use and for some time after use, as it gets very hot. Only hold the bowl by the handle.
5. Move the temperature control knob to the required temperature. See section 'Cooking Guide' to select the right temperature
6. Select the required cooking time (see section 'Cooking Guide').
7. To switch on the appliance, turn the timer knob to the required cooking time. Add 3 minutes to the cooking time stated in the tables on pages 7 and 8 when using the appliance from cold. To set a short time, turn the timer knob until 10 minutes and then go back to the desired time. Note: If you want, you can also let the appliance preheat without any food inside. In this case, turn the timer knob to more than 3 minutes and wait until the heating-up light goes out (after approx. 3 minutes). Then fill the bowl and turn the timer knob to the required cooking time (see Cooking Guide for timings).
 - The timer starts counting down the set cooking time.
 - The heating-up light goes on.

- During the hot air frying process, the heating-up light goes on and off from time to time. This indicates that the heating element is switched on and off to thermostatically maintain the set temperature.
 - Excess oil from the food is collected in the bottom of the bowl
8. Some foods require shaking halfway through the cooking time (see section 'Cooking Guide'). To shake the food, pull the bowl out of the appliance by the handle and shake it. Then slide the bowl back into the Easy Fry. Tip: You can set the timer to half of the cooking time, and when the timer sounds shake the ingredients. Then set the timer again for the remaining cooking time.
 9. When you hear the timer sound, the cooking time set has finished. Pull the bowl out of the appliance and place it on a heat-resistant surface. Note: You can also switch off the appliance manually. To do this, turn the timer control knob to 0.
 10. Check if the food is ready. If the food is not ready yet, simply slide the bowl back into the appliance and set the timer for a few extra minutes.
 11. When the food is cooked, take out the bowl. To remove food, use a pair of tongs to lift the food out of the bowl. Caution: When you turn the bowl, be careful of any excess oil collected at the bottom of the bowl that may leak onto the food and of the grid may fall down. After hot air frying, the bowl, the grid and the food are very hot. Depending on the type of food cooked in the Easy Fry, be careful as steam may escape from the bowl.
 12. When a batch of food is ready, the Easy Fry is instantly ready for preparing another batch of food.

COOKING GUIDE

The table below helps you to select the basic settings for the food you want to prepare. Note: The cooking times below are only a guide and may vary according to the variety and batch of potatoes used. For other foods the size, shape and brand may affect results. Therefore, you may need to adjust the cooking time slightly

| | Min-max Amount (g) | Approx Time (min) | Temperature (°C) | Shake* | Extra information |
|---|--------------------|-------------------|------------------|--------|-------------------|
| Potatoes & fries | | | | | |
| Frozen chips (10 mm x 10 mm standard thickness) | 300-700 g | 15-20 min | 200°C | Shake | |
| Homemade French Fries (8 x 8 mm) | 300 - 800 g** | 22-32 min | 180°C | Shake | Add ½ tbsp of oil |
| Frozen potato wedges | 300 - 800 g | 22-27 min | 180°C | Shake | |

* Shake halfway through cooking.

** Weight of unpeeled potatoes

IMPORTANT: To avoid damaging your appliance, never exceed the maximum quantities of ingredients and liquids indicated in the instruction manual and in the recipes.

| Meat & Poultry | | | | | |
|-----------------------------------|-----------|-----------|-------|--|--|
| Frozen steak | 100-400 g | 9-17 min | 180°C | | |
| Frozen meatballs | 400 g | 8-12 min | 180°C | | |
| Chicken breast fillets (boneless) | 100-500 g | 12-19 min | 180°C | | |
| Chicken (whole) | 1200 g | 60 min | 180°C | | |

| Fish (Times and temperatures are for fresh fish) | | | | | |
|---|-------|-----------|-------|--|--|
| Salmon fillet | 350 g | 15-17 min | 140°C | | |

| | Min-max Amount (g) | Time (min) | Temperature (°C) | Shake | Extra information |
|------------------------|--------------------|------------|------------------|-------|-------------------|
| Snacks | | | | | |
| Frozen chicken nuggets | 100-600 g | 7-12 min | 200°C | | |
| Frozen chicken wings | 300 g | 16-20 min | 200°C | | |
| Frozen cheese sticks | 125 g (5 pieces) | 8 min | 180°C | | |
| Frozen onion rings | 200 g (10 pieces) | 8-10 min | 200°C | Shake | |

| Baking | | | | | |
|---------|-----------|-----------|-------|--|-----------------------------|
| Muffins | 4 x 100 g | 18-22 min | 180°C | | Use a baking tin/oven dish* |

*place the cake tin/oven dish in the bowl.

When you use mixtures that rise (such as with cake, quiche or muffins) the oven dish should not be filled more than halfway

TIPS

- Smaller foods usually require a slightly shorter cooking time than larger size foods.
- A larger amount of food only requires a slightly longer cooking time, a smaller amount of food only requires a slightly shorter cooking time.

- Shaking smaller size foods halfway through the cooking time improves the end result and can help prevent uneven cooking.
- Add some oil to fresh potatoes for a crispy result. After adding a spoon of oil, fry the potatoes within a few minutes.
- Do not cook extremely greasy foods in the Easy Fry.
- Snacks that can be cooked in an oven can also be cooked in the Easy Fry.
- The optimal recommended quantity for cooking fries is 700 grams.
- Use ready made puff and shortcrust pastry to make filled snacks quickly and easily.
- Place an oven dish in the Easy Fry bowl if you want to bake a cake or quiche or if you want to fry fragile ingredients or filled ingredients. You can use an oven dish in silicon, stainless steel, aluminium, terracotta.
- You can also use the Easy Fry to reheat food. To reheat food, set the temperature to 160°C for up to 10 minutes.

MAKING HOME-MADE CHIPS

For the best results, we advise to use frozen chips. If you want to make home-made chips, follow the steps below.

1. Choose a variety of potato recommended for making chips. Peel the potatoes and cut them into equal thickness chips.
2. Soak the potato chips in a bowl of cold water for at least 30 minutes, drain them and dry them with a clean, highly absorbent tea towel. Then pat with paper kitchen towel. The chips must be thoroughly dry before cooking.
3. Pour ½ tablespoon of oil (vegetable, sunflower or olive) in a dry bowl, put the chips on top and mix until they are coated with oil.
4. Remove the chips from the bowl with your fingers or a kitchen utensil so that any excess oil stays behind in the bowl. Place the chips in the bowl. Note: Do not tip the container of oil coated chips directly into the bowl in one go, otherwise excess oil will end up at the bottom of the bowl.
5. Fry the chips according to the instructions in the section Cooking guide.

CLEANING

Clean the appliance after every use.

The bowl and the grid have a non-stick coating. Do not use metal kitchen utensils or abrasive cleaning materials to clean them, as this may damage the nonstick coating.

1. Remove the mains plug from the wall socket and let the appliance cool down. Note: Remove the bowl to let the Easy Fry cool down more quickly.
2. Wipe the outside of the appliance with a damp cloth.
3. Clean the bowl and grid with hot water, some washing-up liquid and a non-abrasive sponge. You can use a degreasing liquid to remove any remaining dirt. Note: The bowl and grid are dishwasher-safe. Tip: If dirt is stuck at the bottom of the bowl and the grid, fill them with hot water and some washing-up liquid. Let the bowl and the grid soak for approximately 10 minutes. Then rinse clean and dry.
4. Wipe inside of the appliance with hot water and a damp cloth.
5. Clean the heating element with a dry, cleaning brush to remove any food residues.
6. Do not immerse the appliance in water or any other liquid.

STORAGE

1. Unplug the appliance and let it cool down.
2. Make sure all parts are clean and dry

Warning

This content is compiled from multiple sources and is provided for reference purposes only. It may not be complete or fully applicable to all situations. If you are unable to resolve your issue, please contact the product manufacturer or an authorized service provider for official support.