

OPERATION

Before Use

Notes for Operation

- Users should keep in mind that frost can form if the door is not closed completely or if the humidity is high during the summer.
- Ensure there is sufficient space between food stored on the shelf or door basket to allow the door to close completely.
- Opening the door for long periods can cause a significant increase of the temperature in the compartments of the appliance.
- If the refrigerating appliance is left empty for long periods, switch off, defrost, clean, dry, and leave the door open to prevent mould developing within the appliance.

Door Open Alarm

The alarm sounds 3 times in 30 second intervals if the door is left open or not completely closed for 1 minute.

NOTE

- Contact the LG Electronics customer information centre if the alarm sound continues even after closing all doors.

Failure Detection

The appliance can automatically detect problems during the operation.

NOTE

- If a problem is detected, the appliance may not operate and an error code is displayed even when any button is pressed.
- If an error code is indicated on the display, do not turn off the power. Immediately contact the
- LG Electronics customer information centre and report the error code. If you turn off the power, the repair technician from the our information centre may have difficulty finding the problem.

Suggestion for Energy Saving

- For the most efficient use of energy, make sure that door bins, drawers and shelves are assembled properly.

- Ensure there is sufficient space between stored foods. This allows cold air to be circulated evenly and lowers electricity bills.
- Store hot food only after it has cooled in order to prevent dew or frost.
- When storing food in the freezer compartment, set the freezer temperature lower than the temperature indicated on the food.
- Do not set the temperature of the appliance lower than needed.
- Do not put food near the temperature sensor of the fridge compartment. Keep a distance of at least 3 cm from the sensor.
- Note that a temperature rise after defrosting has a permissible range in the appliance specifications. If you wish to minimise the impact on the food storage due to a temperature rise, seal or wrap the stored food in several layers.
- The automatic defrosting system in the appliance ensures that the compartment remains free of ice buildup under normal operating conditions.

Storing Foods Effectively

- Food may freeze or spoil if stored at the wrong temperature. Set the refrigerator to the correct temperature for the food being stored.
- Store frozen food or refrigerated food inside sealed containers.
- Check the expiration date and label (storage instructions) before storing food in the appliance.
- Do not store food for a long period of time if it spoils easily at a low temperature.
- Do not place unfrozen food in direct contact with food that is already frozen. It could be necessary to reduce the quantity to be frozen if freezing every day is anticipated.
- Place the refrigerated food or frozen food in each fridge or freezer compartment immediately after purchasing.
- Store raw meat and fish in suitable containers in the refrigerator, so that it is not in contact with or drip onto other food.
- Refrigerated foods and other food items can be stored on top of the vegetable drawer.
- Avoid refreezing any food which has been completely thawed. Freezing any food which has been completely thawed again will lower its taste and nutrition.
- Do not overfill the appliance. Cold air can not circulate properly if the appliance is overfilled.
- Cool hot food before storing. If too much hot food is placed inside, the internal temperature of the appliance can increase and negatively affect other foods stored in the appliance.
- If you set an excessively low temperature for food, it may become frozen. Do not set a temperature lower than the required temperature for the food to be stored correctly.

- If there are chill compartments in the appliance, do not store vegetables and fruits with higher moisture content in the chill compartments as they may freeze due to the lower temperature.
- In the event of a blackout, call the electricity company and ask how long it is going to last.
 - You should avoid door openings while the power is off.
 - When the power supply gets back to normal, check the condition of the food.

Maximum Freezing Capacity

- Express Freeze must be switched on for 7 hours before fresh products are placed in the freezer compartment.
- To get better air circulation, insert all inner parts like baskets and shelves.

NOTE

- The max freezing capacity of your appliance is stated on the rating label inside the fridge compartment.
- For maximum freezing capacity, set the freezer temperature to the coldest temperature setting.

Freezing the Maximum Amount of Food

If large quantities of food are to be stored, all the freezer drawers should be taken out of the appliance and the food should be stacked directly on the freezer shelves in the freezer compartment.

CAUTION

- To remove the drawers, first remove the food from drawers and then pull out the drawers carefully. Not doing so could cause injury or damage to the drawers.

NOTE

- The shape of each drawer may be different, insert in the right position.

Two Star Compartment

- Two star () basket or drawer can be used to store ice and food from -12 °C to -18 °C for short periods.
- Two star frozen food compartments are suitable for storing pre-frozen food, storing or making icecream and making ice cubes.
- Two star compartments are not suitable for the freezing of fresh food.

Product Features

The appearance or components of the appliance may differ from model to model.

Exterior

*1 This feature is only available on some models.

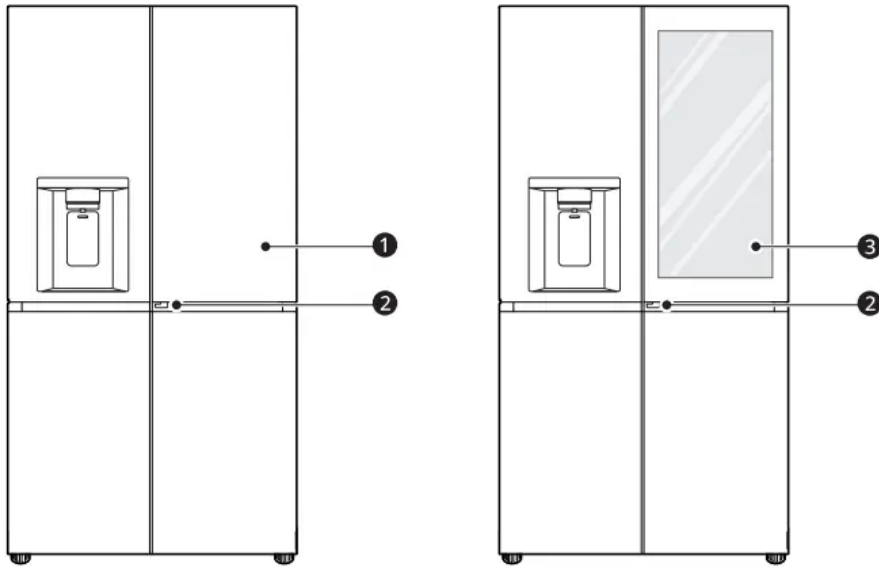

1 Door in Door^{*1}

This is a convenient storage area for frequently-used items that require easy access.

2 Door in Door Lever^{*1}

Opens Door-in-Door.

3 InstaView Door in Door^{*1}

The InstaView Door-in-Door compartment allows for easy access to commonly used food items.

Interior (Two star)

*1 This feature is only available on some models.

Door in Door Model:

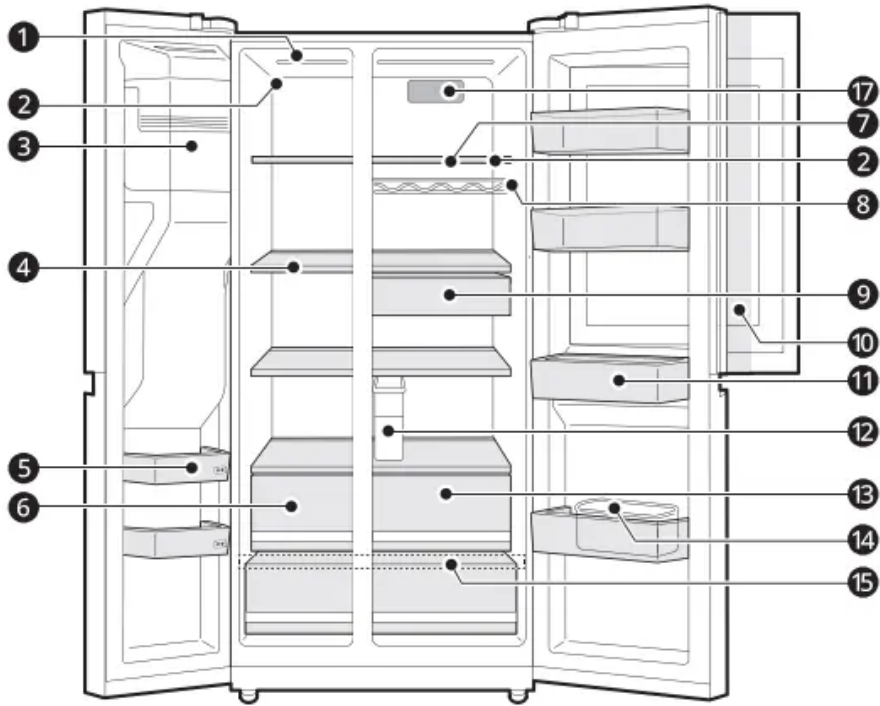

InstaView Door in Door Model:

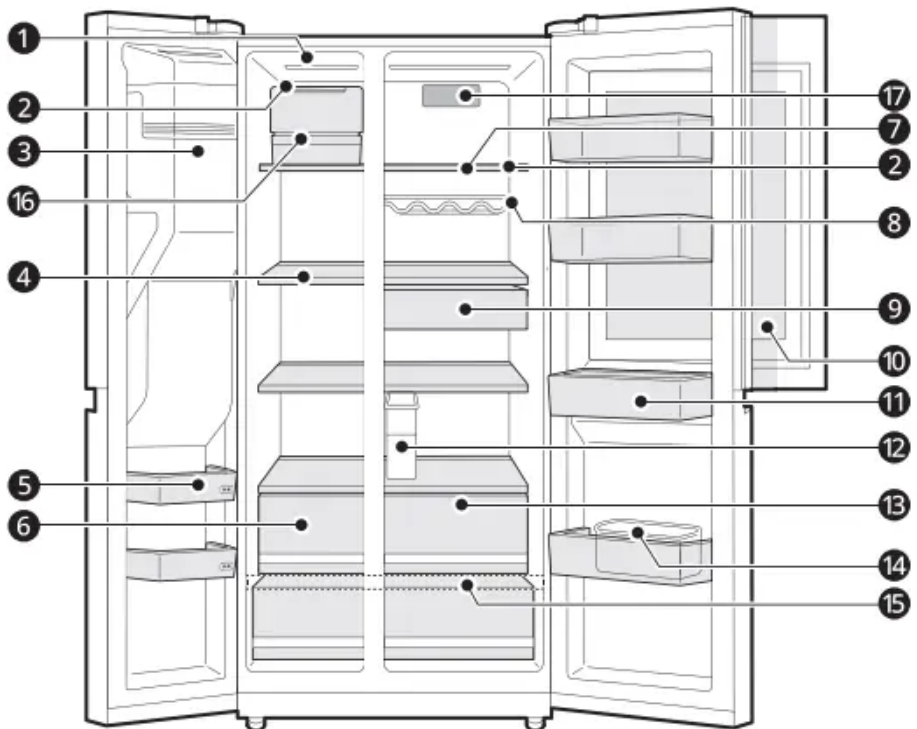

1 LED Lamp

The LED lamps inside the appliance light up when you open the door.

2 Temperature Sensor*1



This sensor senses the temperature of the fridge compartment.

- Maintain the distance between the sensor and food to accurately sense the temperature.

3 Automatic Icemaker*1

This is where ice is automatically produced and stored.

4 Freezer Shelf

Stores frozen food such as meat, fish, and ice cream.

- To freeze food items quickly, store the food on the left side of the top shelf. If you need to store more food, store it on the shelves in order starting from the top shelf. Food items will freeze most quickly in the zone.

5 Freezer Door Basket

Stores small packages of frozen food. Do not store ice cream or food which will be stored for a long period of time.

6 Freezer Drawer

Stores frozen food for longer storage.

7 Fridge Shelf

Stores refrigerated foods and fresh foods.

- Stores the foods with higher moisture content at the front of the shelf.
- The actual number of shelves will differ from model to model.

8 Bottle Rack*1

Stores containers and tall bottles using the bottle rack.

CAUTION

- Do not store short bottles or containers. The items may fall and cause an injury or appliance damage.

9 Snack Drawer*1

Stores small packages of refrigerated foods.

10 Door in Door Compartment*1

Stores commonly used food items such as beverages and snacks.

11 Fridge Door Basket

Stores small packages of refrigerated foods, drinks and sauce containers.

12 Water Tank*1

Stores water to supply the dispenser. It requires manual filling.

13 Fridge Drawer

Stores fruits and vegetables to keep fresh for as long as possible.

14 Egg Box*1

Stores eggs.

- Do not use it as the ice bin or place it on the shelf on top of the fridge or the vegetable drawer.

15 Bottom Drawer Cover

This is the bottom drawer cover.

CAUTION

- Do not store any items at the front of the bottom shelf. The items may fall and cause an injury or appliance damage.

16 Craft Ice Maker*1

This is where craft ice is automatically produced and stored.

17 Air Filter*1

Reduces odours inside the fridge compartment.

Control Panel

The actual control panel may differ from model to model.

Control Panel and Functions

*1 This feature is only available on some models.

Control Panel

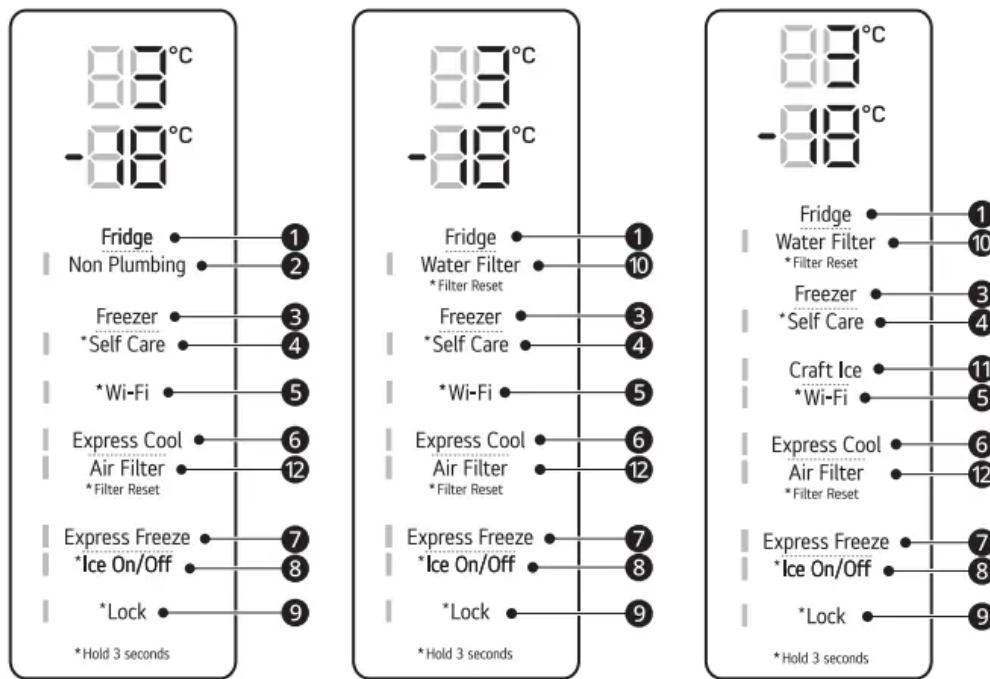

Dispenser Control Panel

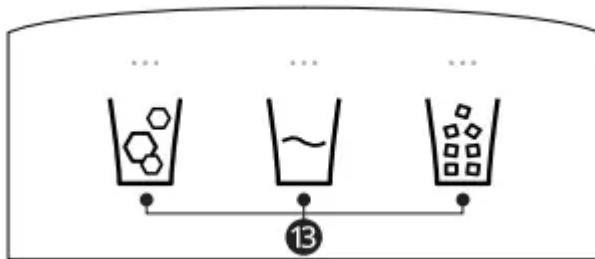

❶ Fridge

Press this button repeatedly to select a desired temperature between 1 °C and 7 °C.

- The default fridge temperature is 3 °C.

NOTE

- The actual inner temperature varies depending on the food status, as the indicated setting temperature is a target temperature, not actual temperature within the appliance.

❷ Non Plumbing*1

The Non Plumbing icon is illuminated when the water dispenser tank is installed correctly.

❸ Freezer

Press this button repeatedly to select a desired temperature between -23 °C and -15 °C.

- The default freezer temperature is -18 °C.

4 Self Care*1

UV light is used to keep the water outlet clean. UV clean function runs automatically for 10 minutes every hour or can be manually activated at anytime.

Press this button to activate it manually.

NOTE

- This function will momentarily stop each time the Water button is pressed if it is in operation and will resume the function after 1 hour.
- This function runs automatically for 10 minutes every hour without pressing the Self Care button.
- When UV clean function is activated the LED on the dispenser control panel lights up.
- **UVnano** is a compound word derived from the words UV and its unit, nanometer.

5 Wi-Fi

This button allows the appliance to connect to a home Wi-Fi network. Refer to Smart Functions for information on the initial setup of the LG ThinQ application.

6 Express Cool

This function can quickly cool a large amount of foods such as vegetable, fruit and so on.

- This function is enabled and disabled in turn each time you press the button.
- This function automatically terminates after a specific period has passed.

7 Express Freeze

This function can quickly freeze a large amount of ice or frozen foods.

- Press the Express Freeze button to activate the function for 20 hours. The function automatically shuts off after 20 hours.
- This function is enabled and disabled in turn each time you press the button.
- This function automatically terminates after a specific period has passed.

8 Ice On/Off

Press and hold the Ice On/Off button for three seconds to turn the automatic icemaker On/Off.

9 Lock

The lock function disables every other button on the display.

- To lock the control panel buttons, press and hold the Lock button for 3 seconds until indicator light turns on and the function is activated.

- To disable the function, press and hold the Lock button for 3 seconds until the indicator light turns off and the function is deactivated.

10 Water Filter*1

Replace the water filter when the indicator light turns on.

11 Craft Ice*1

Press the Craft Ice button to set to 6 ICE, 3 ICE or OFF.

NOTE

- For more ice, select the 6 ICE mode. For clearer ice, select the 3 ICE mode.
- To change the Craft Ice mode:
 1. Press the Craft Ice button and the current mode appears.
 2. Press the Craft Ice button repeatedly to select a desired Craft Ice mode.
 3. After 5 seconds of idle time, the last mode set will be saved, and the display will return to normal.

12 Air Filter*1

Replace the air filter when the indicator light turns on. After replacing the air filter, press and hold the Air Filter button for 3 seconds to turn the indicator light off. Replace the air filter approximately every six months.

13 Water & Ice Type*1

Select the desired dispenser mode from the buttons on the dispenser control panel. Press the dispenser switch with a glass or other container to dispense cubed ice, water or crushed ice.

NOTE

- The displayed temperature is the target temperature, and not the actual temperature inside the appliance.
- The actual temperature inside the appliance depends on the following factors: room temperature, the amount of food and how often the doors are opened, where the appliance is. Set the temperatures by considering these factors.
- If there is any finger or skin contacts to the control panel while cleaning it, the button function may operate.
- This appliance incorporates an earth connection for functional purposes only.

Ice and Water Dispenser

Before Using the Ice and Water Dispenser

CAUTION

- Keep children away from the dispenser to prevent children playing with or damaging the controls.
- Throw away the first few batches of ice (about 20 cubes and 7 cups of water). This is also necessary if the appliance has not been used for a long time.
- Clean the water dispensing system if they have not been used for 48 hours. Flush the water system connected to a water supply if water has not been drawn for 5 days.
- To clean the water dispensing system, flush the water through the dispenser about 5 minutes and throw away the first few batches of ice.
- Do not use a thin crystal cup or chinaware when dispensing water or ice.

NOTE

- If you open the freezer door while water is being dispensed, the water dispensing will stop.

If you open the fridge door while water, cubed ice or crushed ice is being dispensed, dispensing will be paused. When you close the door, the selected item will continue to be dispensed.

- If the cup rim is small, water may splash out of the glass or miss it completely.
- Use a cup with a rim of over 68 mm in diameter when dispensing water, cubed ice or crushed ice.
- When the ice maker produces smaller ice cubes, or the cubes become lumped together, the amount of water supplied to the ice maker may be low due to insufficient water in the water tank. If ice is not used frequently or the freezer set temperature is too warm, it may also lump together.
- It is normal for milky / cloudy water to be dispensed after replacing the water filter. This air in the water will eventually clear and is safe to drink during this transition.

Using the Ice and Water Dispenser

1

Press the dispenser selection button **1**, and then the LED above the icon that you want illuminates.

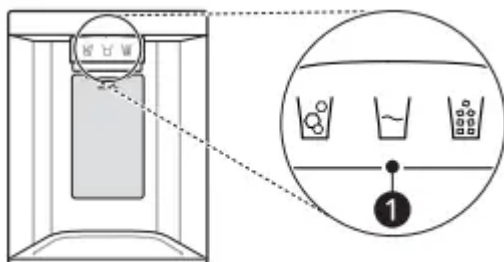

2 Press the dispenser paddle **2** with a glass or other container to dispense cubed ice, water or crushed ice.

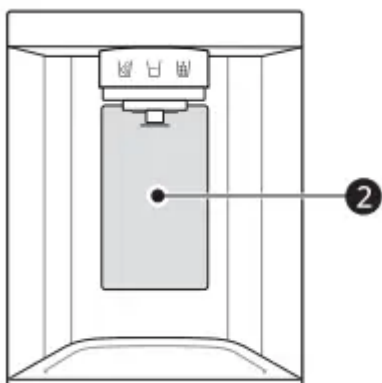

Cleaning the Dispenser

Cleaning the Ice and Water Outlet

Wipe the water outlet **1** or ice outlet **2** frequently with a clean cloth as it may get dirty easily.

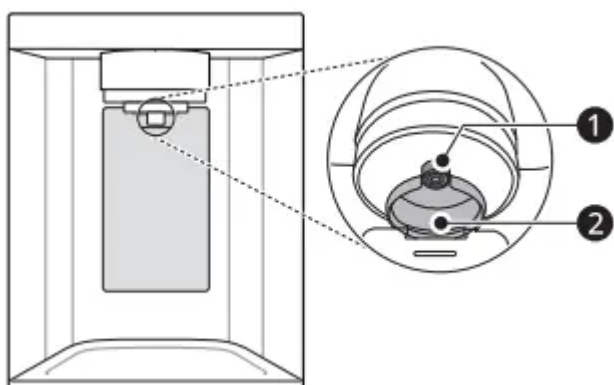

NOTE

- Lint from a cloth may adhere to the outlets.

Cleaning the Dispenser Tray

Wipe the entire area with a damp cloth. The dispenser tray may become wet easily due to spilled ice or water.



Filling the Water Tank with Water

This feature is only available on some models.

The water tank holds the water to be dispensed or used by the automatic icemaker to make ice.

- 1** Remove the water dispenser tank by pulling it out while holding the handle.

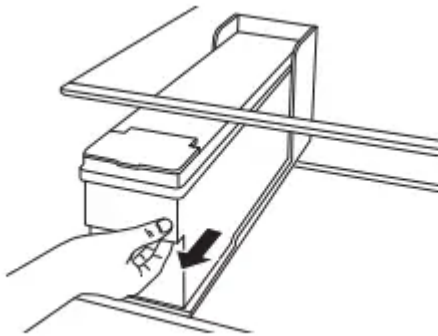

- 2** Open the cover or cap of the water dispenser tank.

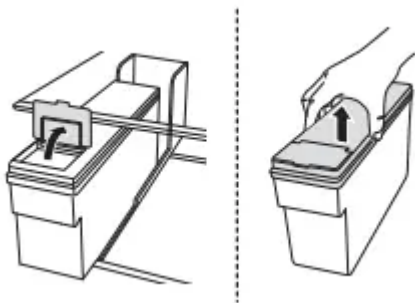

- 3** Fill with bottle filtered or clean filtered water up to the reference line indicated inside the water dispenser tank. (Total capacity: 4 ℓ)

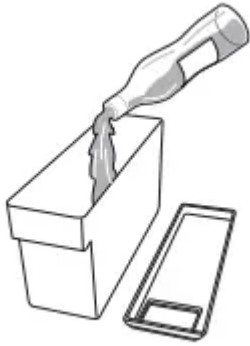

- 4** After filling with water, close the cover or cap of the water dispenser tank.

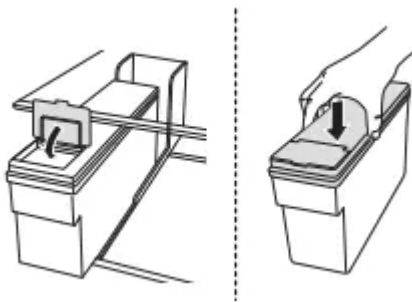

- 5** Refit the water dispenser tank on the fridge shelf.

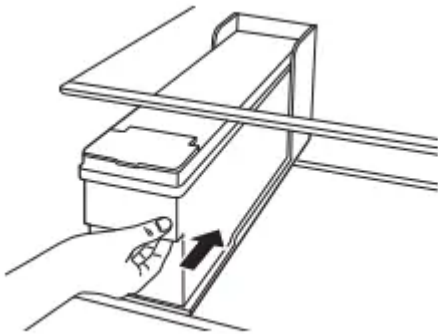

WARNING

- Fill with potable water only into icemaker or dispenser water tank.
- Do not fill the water tank with drinks other than water or fill with hot water.

CAUTION

- Do not apply excessive force or impact when removing or assembling the water dispenser tank. Doing so can cause appliance damage or injury.
- Children should not be allowed near the dispenser tank.

NOTE

- Before using the water dispenser tank after installing the appliance, it should be washed before filling it with water.
- Check if the water dispenser tank has been placed on the appliance correctly. If it is not assembled correctly, water may leak from the tank into the appliance.
- If there is an insufficient amount of water in the water dispenser tank, ice cube size and quantity may be affected and may result in no ice being made.
- If there is no water in the water dispenser tank, the cold water and ice dispensing function of the dispenser cannot be used. Check if there is water in the water dispenser tank and then fill it with water if there is not.
- Wait at least 15 seconds before removing the water tank after having dispensed water or ice from the dispenser.

NOTE

- Sound from the water tank will be normal when supplying water to the dispenser and the Automatic Ice Maker. It is not a sign of malfunction.

Automatic Icemaker

This feature is only available on some models.

This feature may vary depending on model purchased.

Before Using the In-Door Icemaker

- The icemaker produces ice normally when approximately 48 hours have passed after the appliance is initially installed.
- If the ice bin is completely filled with ice, ice production will stop.
- Sound of ice dropping into the ice bin is normal.
- If ice cubes are stored in the ice bin for a long period of time, they may clump together and may not be separated easily. In such a case, empty the ice bin and allow fresh ice to be made.

CAUTION

- It is normal for milky or cloudy water to be dispensed after replacing the water filter. This air in the water will clear eventually and is safe to drink.
- The first ice and water dispensed may include particles or odour from the water supply line or the water tank.
- If discolored ice is dispensed, check the water tank and the water supply for a possible source.

- If the problem continues, contact the LG
- Electronics customer information centre. Do not use the ice or water until the problem is corrected.
- Do not touch the ice outlet or the automatic icemaker with your hand or a tool.
- Dispense ice into a glass before filling it with water or other beverages. Splashing will occur if ice is dispensed into a glass that already contains liquid.
- Never use a glass that is exceptionally narrow or deep. Ice may jam in the ice passage, affecting the performance of the appliance.
- Keep the glass at a proper distance from the ice outlet. A glass held too close to the outlet may prevent ice from dispensing.
- Dispose of the ice inside the ice bin if you go on vacation or if an extended power outage occurs.
- Water from melting ice may drop from the dispenser onto the floor.

In-Door Icemaker

The automatic icemaker can automatically make 70 -182 cubes within a 24-hour period if conditions are favourable. This amount may vary according to the environment (ambient temperature around the appliance, frequency of the door being opened, amount of food stored in the appliance, etc.).

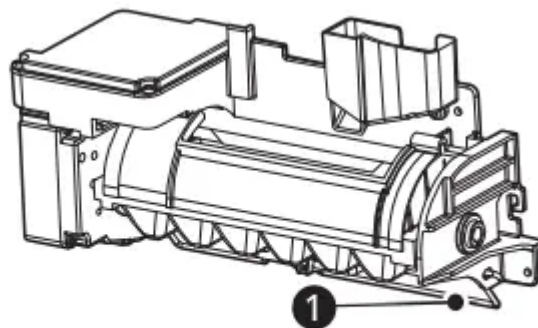

1 Auto Shutoff (feeler arm)

Before Using the Freezer Icemaker

NOTE

- The icemaker begins producing ice approximately 48 hours after the appliance is initially installed.
- Throw away the first few batches of ice after installation.
- The sound of ice dropping into the ice bin is normal.
- If the ice bin is completely filled with ice, ice production will stop.

- The amount and shape of ice may vary according to the environment (ambient temperature around the appliance, frequency of the door being opened, amount of food stored in the appliance, water pressure, etc.).
- In the event of a power outage, throw away the ice stored in the ice bin.

Freezer Icemaker (Craft Ice)

This feature is only available on some models.

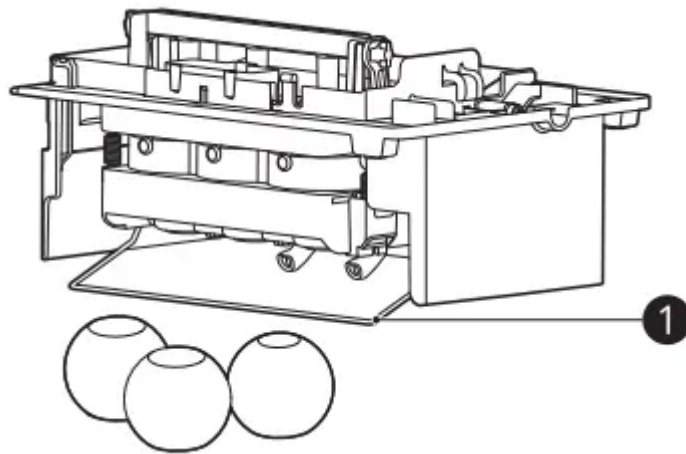

CAUTION

- Do not insert round ice into the in-door ice bin, as it can damage the ice and water dispenser.

NOTE

- The icemaker begins producing ice approximately 48 hours after the appliance is initially installed. The first batches of ice may not be round and clear.
- Following installation or water filter replacement, the first few batches of ice may be semicircular or contain air bubbles.
- If the water pressure is less than 20 psi (138 kPa) or a reverse osmosis system is used, the shape of the ice may vary.
- The ice may look cloudy depending on the water quality in the installation location and the operating conditions.
- Throw away any shards of ice you may find in the ice bin, as they may stick to the ice stored in the ice bin.
- After a short term power outage, it will take longer to make the first batch of ice, and the ice may not be round. If the power will be out for a longer period, throw away the ice stored in the ice bin.
- The Craft Ice icemaker produces 1 batch of round ice (3 pieces) at a time.

- In 3 ICE mode, the Craft Ice icemaker produces batch of round ice (3 pieces) about every 24 hours. In 6 ICE mode, the Craft Ice icemaker produces 2 batches of round ice (6 pieces total) in the same period.
- For more ice, select the 6 ICE mode. For clearer ice, select the 3 ICE mode.
- The time needed to make ice may vary according to operating conditions.
- The ice bin stores 20 - 30 pieces of round ice.

Removing/Refitting the Ice Storage Bin

The ice dispensing chute may become blocked with frost if only crushed ice is used. Remove the frost that accumulates by removing the ice bin and clearing the passage with a rubber spatula.

Dispensing cubed ice periodically can also help prevent frost buildup.

1 Turn off the automatic icemaker. Press and hold the Ice On/Off button on the control panel for 3 seconds.

2 Hold and remove the cover of the automatic icemaker by lifting it upward.

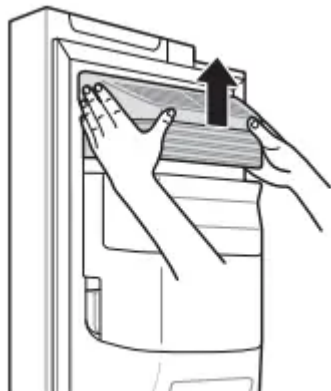

3 Hold the ice bin with both hands and pull it out while lifting it upward.

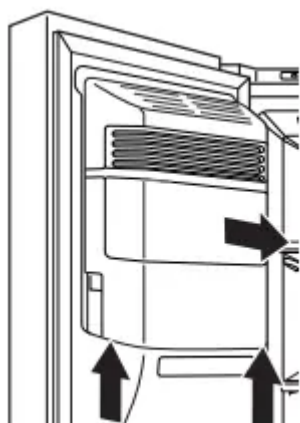

4

Refit the in-door ice bin in the reverse sequence of their removal.

CAUTION

- Do not touch the automatic icemaker's mechanical parts with your hand or a tool.
- Otherwise, appliance damage or injury may occur.
- Do not disassemble, repair or alter the automatic icemaker. These tasks should only be done by a service technician.
- Caution should be taken, as the automatic icemaker operates continuously after the freezer door is opened when the automatic icemaker switch is set to the on position.
- Keep children away from the dispenser.
- When refitting the ice bin, ensure that it is placed correctly. If it is tilted or unlevel, it may not continue to make ice due to sensor disruption.

Turning the Icemaker On/Off

To turn the automatic icemaker On/Off, press and hold the Ice On/Off button on the control panel for three seconds.

Normal Sounds You May Hear

- Keeping the power turned on to the icemaker before the water line is connected can damage the icemaker.
- The icemaker water valve buzzes as the icemaker fills with water. If the Ice On/Off button is set to On, it will buzz even if it has not yet been hooked up to water. To stop the buzzing, press the Ice On/Off button to Off position.
- You will hear the sound of ice dropping into the bin and water running in the pipes as the icemaker refills.

Preparing for Vacation

Set the Ice On/Off button to Off and shut off the water supply to the appliance.

NOTE

- The ice bin should be emptied any time the Ice On/Off button is turned Off.

If the ambient temperature will drop below freezing, have a qualified technician drain the water supply system to prevent serious property damage due to flooding caused by ruptured water lines or connections.

InstaView

This feature is only available on some models.

Using the InstaView Door in Door

The InstaView Door in Door lets you see if you're running low on frequently used items like beverages and snacks, without opening the fridge door.

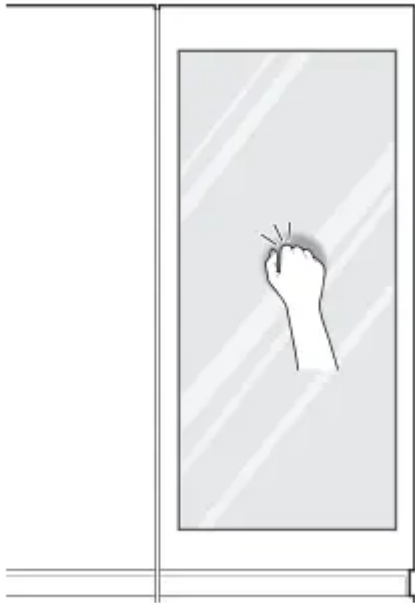

1 Knock twice on the glass to turn the LED light inside the Door in Door on or off.

2 The LED light turns off automatically after ten seconds.

CAUTION

- Do not open the door of the appliance with the door in door open, or do not open the door in door while the door of the appliance is open. The door in door may be struck by the edge of the appliance and damaged.

NOTE

- The InstaView Door in Door function is disabled for 2 seconds after closing the left or right freezer door, and momentarily disabled whilst the ice dispenser is in use.
- Knock near the center of the glass. Knocking near the edges of the glass may not activate the InstaView Door in Door function.
- Knock hard enough so that the knocking sound is audible.
- The InstaView Door in Door function may activate if a loud noise occurs near the refrigerator.
- Clean the glass door with a dry cloth. To remove stubborn stains, slightly moisten a clean cloth with lukewarm water or a glass cleaner. Do not spray glass cleaner directly at the glass door.

Door in Door

This feature is only available on some models.

Using the Door in Door

Pull the lever at the bottom of the door upwards until the door in door opens.

There is plenty of storage space inside the door in door and its surrounding baskets, allowing you to store food in an organized manner.

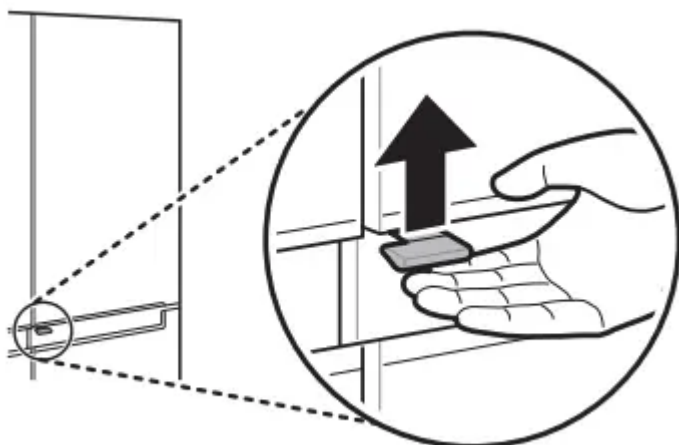

CAUTION

- Do not open the door of the appliance with the door in door open, or do not open the door in door while the door of the appliance is open. The door in door may be struck by the edge of the appliance and damaged.

Drawer

CAUTION

- Always empty the drawers before removing them, and use both hands when removing and refitting them.
- Make sure that the fridge doors are fully open before removing and refitting the drawers.

Using the Vegetable Drawer

The humidity in the vegetable crisper drawer can be controlled by sliding the lever in either direction.

- If moved to the left side, the air guide will be open and allow air to circulate through the drawer for reduced humidity.
- If moved to the right side, the air guide will be closed and will maintain any humidity that is currently in the crisper drawer.

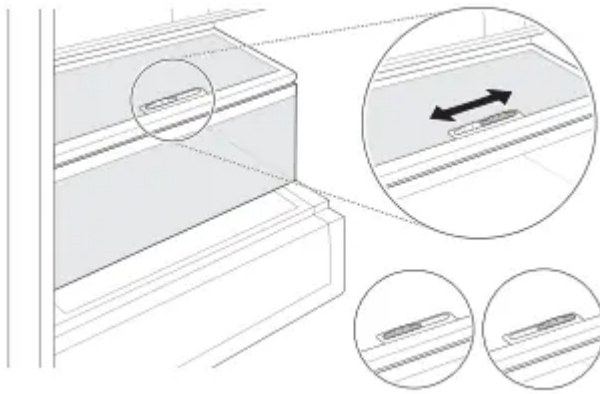

1 Remove the contents of the drawer. Hold the handle of the vegetable drawers and gently pull them out.

2 Lift the vegetable drawer up and remove it by pulling it out.

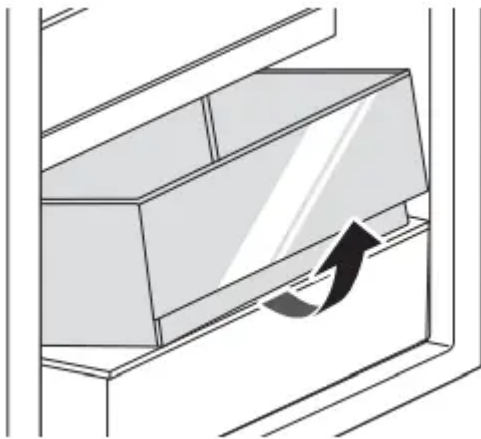

3 Refit the drawer in the reverse order of the removal process.

CAUTION

- Always empty the drawers before removing them, and use both hands when removing and refitting them.
- Make sure that the fridge doors are fully open before removing and assembling the drawers.

Shelf

CAUTION

- Glass shelves are heavy. Use special care when removing them.
- Do not clean glass shelves with warm water while they are cold. Shelves may break if exposed to sudden temperature changes or impact.

Removing/Refitting the Shelf

1 Tilt up the front of the shelf and then lift the shelf straight up.

2 Pull the shelf out.

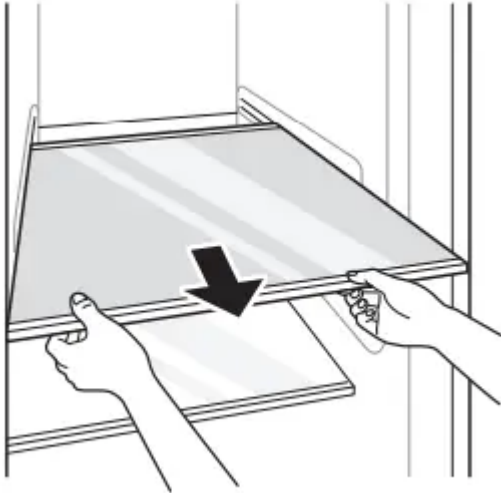

3 Mount them in the reverse order of the removal process.

CAUTION

- Glass shelves are heavy. Use special care when removing them.
- Do not clean glass shelves with warm water while they are cold. Shelves may break if exposed to sudden temperature changes or impact.
- Make sure that shelves are level from one side to the other. Failure to do so may result in the shelf falling or food spilling.

Door Basket

Removing/Refitting the Door Basket

1 Hold both edges of the basket and remove it by lifting it upward.

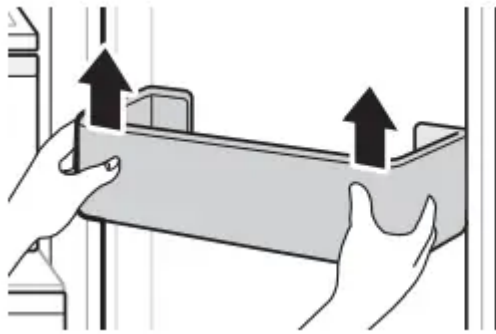

- 2 Refit the door baskets in the reverse order of the removal process.

SMART FUNCTIONS

LG ThinQ Application

This feature is only available on models with Wi-Fi.

The LG ThinQ application allows you to communicate with the appliance using a smartphone.

LG ThinQ Application Features

Communicate with the appliance from a smartphone using the convenient smart features.

Smart Diagnosis

- If you experience a problem while using the appliance, this smart diagnosis feature will help you diagnose the problem.

Settings

- Allows you to set various options on the appliance and in the application.

NOTE

- If you change your wireless router, internet service provider, or password, delete the registered appliance from the LG ThinQ application and register it again.
- The application is subject to change for appliance improvement purposes without notice to users.
- Functions may vary by model.

Before Using LG ThinQ Application

- 1 Check the distance between the appliance and the wireless router (Wi-Fi network).

- If the distance between the appliance and the wireless router is too far, the signal strength becomes weak. It may take a long time to register or installation may fail.

2 Turn off the Mobile data or Cellular Data on your smartphone.

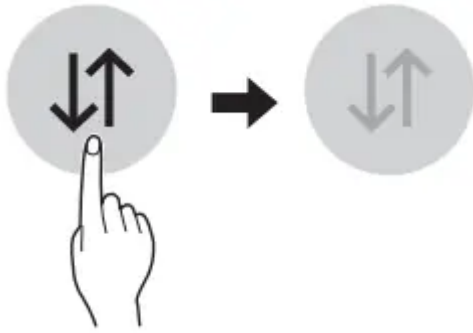

3 Connect your smartphone to the wireless router.

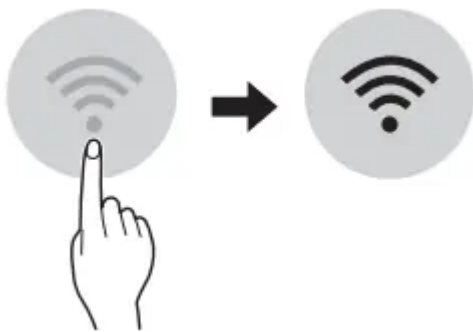

NOTE

- To verify the Wi-Fi connection, check that the WiFi indicator on the control panel is lit.
- The appliance supports 2.4 GHz Wi-Fi networks only. To check your network frequency, contact your Internet service provider or refer to your wireless router manual.
- LG ThinQ is not responsible for any network connection problems or any faults, malfunctions, or errors caused by network connection.
- If the appliance is having trouble connecting to the Wi-Fi network, it may be too far from the router. Purchase a Wi-Fi repeater (range extender) to improve the Wi-Fi signal strength.
- The Wi-Fi connection may not connect or may be interrupted because of the home network environment.
- The network connection may not work properly depending on the Internet service provider.
- The surrounding wireless environment can make the wireless network service run slowly.
- The appliance cannot be registered due to problems with the wireless signal transmission.
- Unplug the appliance and wait about a minute before trying again.

- If the firewall on your wireless router is enabled, disable the firewall or add an exception to it.
- The wireless network name (SSID) should be a combination of English letters and numbers. (Do not use special characters.)
- Smartphone user interface (UI) may vary depending on the mobile operating system (OS) and the manufacturer.
- If the security protocol of the router is set to WEP, you may fail to set up the network. Please change it to other security protocols (WPA2 is recommended) and register the product again.

Installing the LG ThinQ Application

Search for the LG ThinQ application from the

Google Play Store or Apple App Store on a smartphone. Follow instructions to download and install the application.

Connecting to Wi-Fi

The Wi-Fi button, when used with the LG ThinQ application, allows the appliance to connect to a home Wi-Fi network. The Wi-Fi indicator shows the status of the appliance's network connection. The

Wi-Fi indicator illuminates when the appliance is connected to the Wi-Fi network.

• Initial Appliance Registration

Run the LG ThinQ application and follow the instructions in the application to register the appliance.

• Re-registering the Appliance or Registering Another User

Press and hold the Wi-Fi button for 3 seconds to temporarily turn it off. Run the LG ThinQ application and follow the instructions in the application to register the appliance.

NOTE

- To disable the Wi-Fi function, press and hold the Wi-Fi button for 3 seconds. The Wi-Fi indicator will be turned off.

RF Radiation Exposure Statement

This equipment shall be installed and used at a minimum distance of 20 cm from the human body.



Open Source Software Notice Information

To obtain the source code under GPL, LGPL, MPL, and other open source licenses, that is contained in this product, please visit <https://opensource.lge.com>.

In addition to the source code, all referred license terms, warranty disclaimers and copyright notices are available for download.

LG Electronics will also provide open source code to you on CD-ROM for a charge covering the cost of performing such distribution (such as the cost of media, shipping, and handling) upon email request to opensource. This offer is valid for a period of three years after our last shipment of this product. This offer is valid to anyone in receipt of this information.

Smart Diagnosis

This feature is only available on models with the  or  logo.

Use this feature to help you diagnose and solve problems with your appliance.

NOTE

- For reasons not attributable to LGE's negligence, the service may not operate due to external factors such as, but not limited to, Wi-Fi unavailability, Wi-Fi disconnection, local app store policy, or app unavailability.
- The feature may be subject to change without prior notice and may have a different form depending on where you are located.

Using LG ThinQ to Diagnose Issues

If you experience a problem with your Wi-Fi equipped appliance, it can transmit troubleshooting data to a smartphone using the LG ThinQ application.

- Launch the LG ThinQ application and select the Smart Diagnosis feature in the menu. Follow the instructions provided in the LG ThinQ application.

Using Audible Diagnosis to Diagnose Issues

Follow the instructions below to use the audible diagnosis method.

- Launch the LG ThinQ application and select the Smart Diagnosis feature in the menu. Follow the instructions for audible diagnosis provided in the LG ThinQ application.

1

Press the Lock button to activate the lock function.

- If the display has been locked for over 5 minutes, you must deactivate the lock and then reactivate it.

2

Open the fridge door and then hold the phone on the upper right speaker hole.

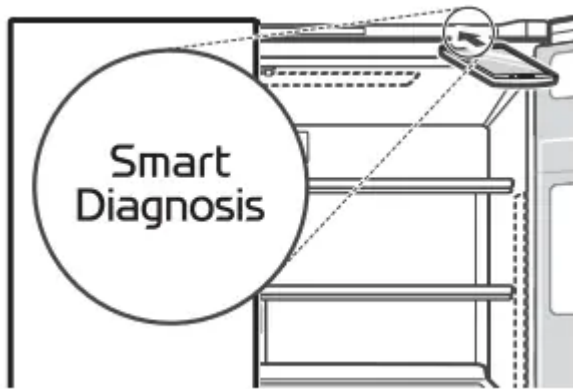

3 Press and hold the Freezer button for three seconds or longer while holding your phone to the speaker until the data transfer is complete.

4 After the data transfer is complete, the diagnosis will be displayed in the application.

NOTE

- For best results, do not move the phone while the tones are being transmitted.

MAINTENANCE

Cleaning

General Cleaning Tips

- Performing manual defrosting, maintenance or cleaning of the appliance while food is stored in the freezer can raise the temperature of the food and reduce its storage life.
- Regularly clean any surfaces that can come in contact with food.
- When cleaning the inside or outside of the appliance, do not wipe it with a rough brush, toothpaste, or flammable materials. Do not use cleaning agents containing flammable substances. This may cause discolouration or damage to the appliance.
 - Flammable substances: alcohol (ethanol, methanol, isopropyl alcohol, isobutyl alcohol, etc.), thinner, bleach, benzene, flammable liquid, abrasive, etc.
- After cleaning, check if the power cable is damaged.

Cleaning the Exterior

- When cleaning the outside air vents of the appliance by means of vacuuming, then the power cord should be unplugged from the outlet to avoid any static discharge that can damage the electronics or cause an electric shock.
- Regular cleaning of the rear and side ventilation covers is recommended to maintain reliable and economical operation of the unit.

- Keep the air vents on the exterior of the appliance clean. Blocked air vents can cause fire or appliance damage.
- For the appliance exterior, use a clean sponge or soft cloth and a mild detergent in warm water.
- Do not use abrasive or harsh cleaners. Dry thoroughly with a soft cloth. Do not use contaminated cloths when cleaning the stainless steel doors. Always use a dedicated cloth and wipe in the same direction as the grain. This helps reduce surface staining and tarnishing. A Stainless Steel protection solution can also be applied to further protect the finish.

Cleaning the Interior

- When removing a shelf or drawer from inside the appliance, remove all stored foods from the shelf or drawer to prevent injury or damage to the appliance. Otherwise, injury may occur due to the weight of stored foods.
- Detach the shelves and drawers and clean them with water, and then dry them sufficiently, before replacing them.
- Regularly wipe the door gaskets with a wet soft towel.
- Door basket spills and stains should be cleaned as they can compromise storage ability of the basket and could even be damaged.
- Never clean the shelves or containers in the dishwasher. The parts may become deformed due to the heat.
- The automatic defrosting system in the appliance ensures that the compartment remains free of ice buildup under normal operating conditions. Users do not need to defrost it manually.

Cleaning the Condenser Cover

Use a vacuum cleaner with a brush to clean the condenser cover and vents. Do not remove the panel covering the condenser coil area.

We recommend that this be done every 12 months to maintain operating efficiency.

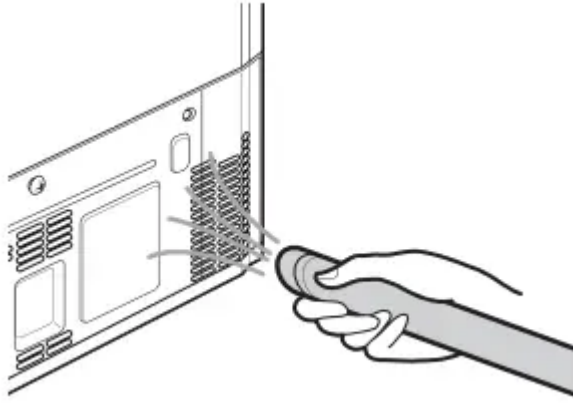

Water Filter

This feature is only available on some models.

Before Replacing the Water Filter

WARNING

- Do not allow children to have access to small parts during the installation of this product.
- Do not use with water that is microbiologically unsafe or of unknown quality without adequate disinfection before or after the system. Systems certified for cyst reduction may be used on disinfected water that may contain filterable cysts.

CAUTION

- Do not install if water pressure exceeds 827 kPa.
- If your water pressure exceeds 827 kPa, you must install a pressure limiting valve. Contact a plumbing professional if you are uncertain how to check your water pressure.
- Do not install where water hammer conditions may occur. If water hammer conditions exist, you must install a water hammer arrester.
- Contact a plumbing professional if you are uncertain how to check for this condition.
- Do not install on hot water supply lines. The maximum operating water temperature of this filter system is 37.8 °C.
- Protect filter from freezing. Drain filter when temperatures drop below 4.4 °C.
- The disposable filter cartridge MUST be replaced every 6 months, at the rated capacity or if a noticeable reduction in flow rate occurs.
- Where a backflow prevention device is installed on a water system, a device for controlling pressure due to thermal expansion must be installed.
- Ensure all tubing and fittings are secure and free of leaks.

NOTE

- While the testing was performed under standard laboratory conditions, actual performance may vary.
- It is essential that the manufacturer's recommended installation, maintenance and filter replacement requirements be carried out for the product to perform as advertised.

Replacing the Water Filter (Plumbed Model)

*1 This feature is only available on some models.

The filter must be changed every 6 months or when the indicator lights turns on or the water dispenser output decreases.

- To purchase a replacement water filter:
 - Use replacement cartridge: ADQ736939**
 - Visit your local dealer or distributor or contact the LG Electronics Customer Information

Centre. For further assistance, visit our website at lg.co

Thread Nut Type*1

- 1** Loosen the screw cap.

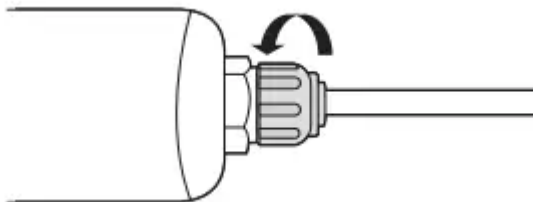

- 2** Pull the pipe out from the water filter cap until the colored line **1** is visible.

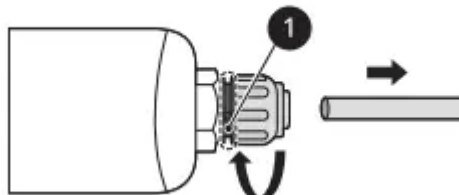

- 3** Push the pipe into the water filter cap, making sure the end is fully sealed.

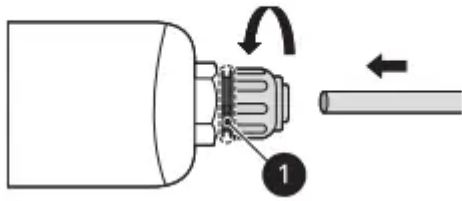

4 Tighten the screw cap until the colored line in the water filter is no longer visible.

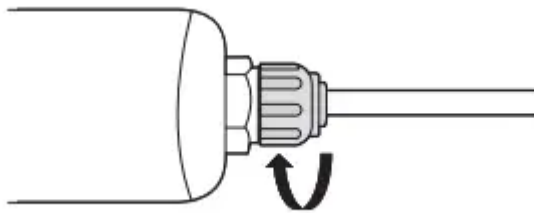

5 Press and hold the Water Filter button for three seconds. That resets the Replacement Filter icon. The new water filter has been activated.

6 Dispense water for approximately 5 minutes to remove trapped air and contaminants from the system.

Push fit connector type*1

1 Remove the screw cap.



2 Pull the pipe out from the water filter.

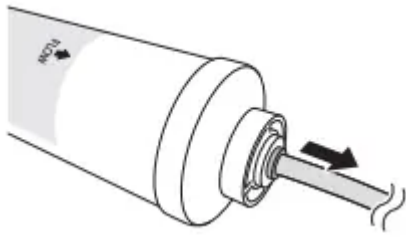

3 Push the pipe into the water filter, making sure the end is fully sealed.

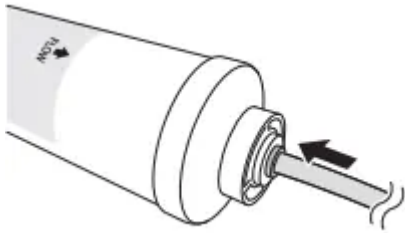

4 Insert the screw cap until the colored line in the water filter is no longer visible.

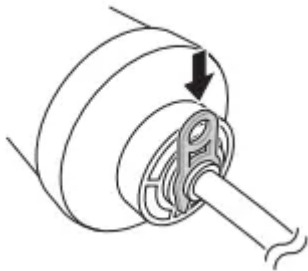

5 Press and hold the Water Filter button for three seconds. That resets the Replacement Filter icon. The new water filter has been activated.

6 Dispense water for approximately 5 minutes to remove trapped air and contaminants from the system.

CAUTION

- Failure to replace filters when required or using non LG authorised water filters can cause the filter cartridge to leak and result in property damage.

Application Guidelines/Water Supply Parameters

- Service Flow: 1,9 lpm
- Water Supply: Community or Private Well - Potable Water
- Water Pressure: 138 - 827 kPa

- Water Temperature: 0,6 - 37,8 °C
- Capacity: 1 892 litres

Air Filter

This feature is only available on some models.

Replacing the Air Filter

- Replace the air filter:
 - Approximately every six months.
 - When the air filter indicator lights up.
- To purchase the air filter:
 - Visit your local dealer or distributor or contact the LG Electronics Customer Information Centre. For further assistance, visit our website

1 Rotate the filter cover counterclockwise to release the tabs, and remove the cover.

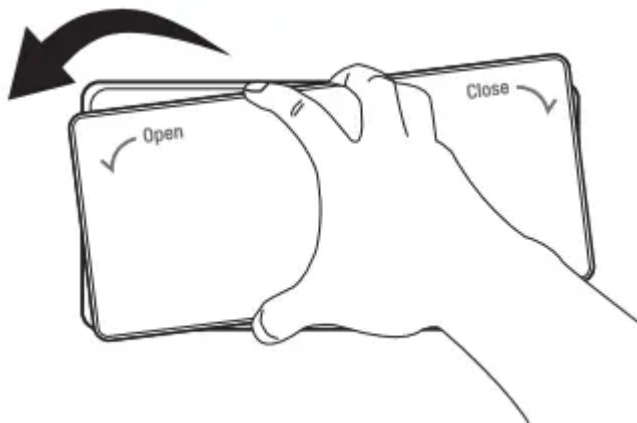

2 Remove the filter from the inside of the cover by pressing the side of the filter in and pulling the centre out.

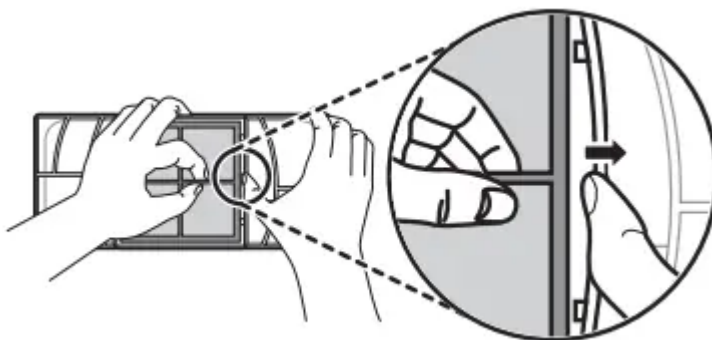

- 3** Place the new filter inside of the cover with the side that says FRONT facing outward.

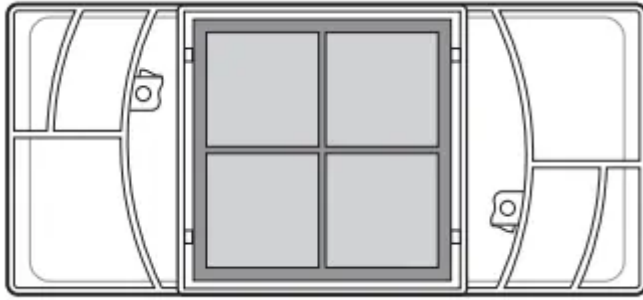

- 4** Align tabs **1** on the filter cover with hooks **2** on the fridge wall.

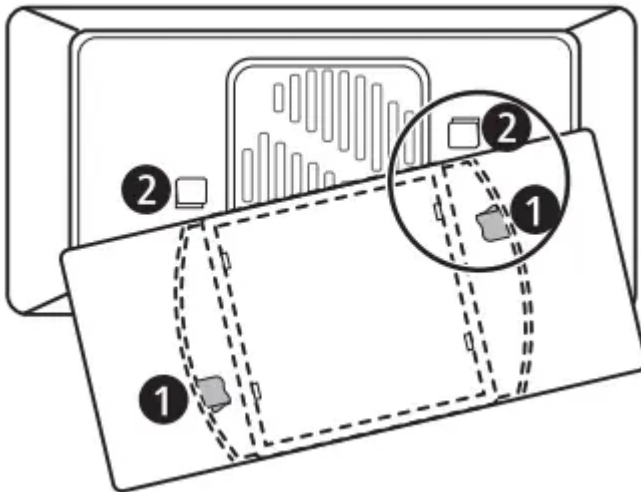

- 5** Rotate the air filter cover clockwise until the hooks engage and the cover locks in place.

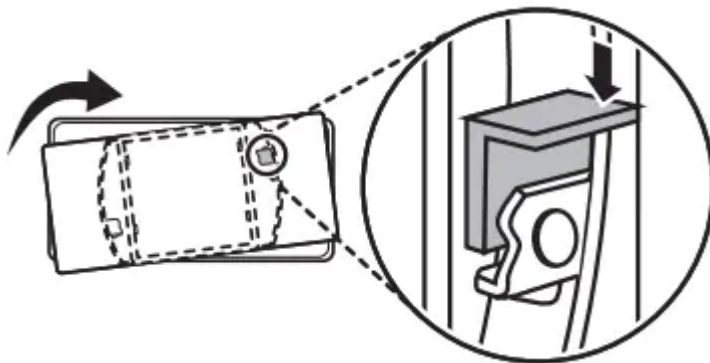

- 6** Press and hold the Air Filter button on the control panel for 3 seconds to reset the filter.

CAUTION

- If you wash the filter with water, the filter performance may also deteriorate.
- Caution should be taken not to change the direction of the filter to be inserted into the filter cover.

Deodorizer

Reusing the Deodorizer

You can re-use the deodorizer by removing odors from the deodorizer.

- 1** Pull out the upper fridge drawer.

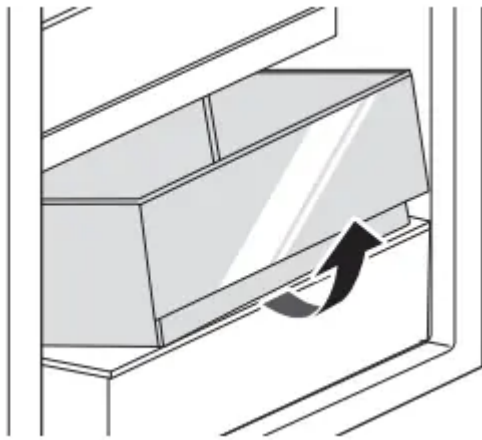

- 2** Unscrew the screw at the deodorizer.

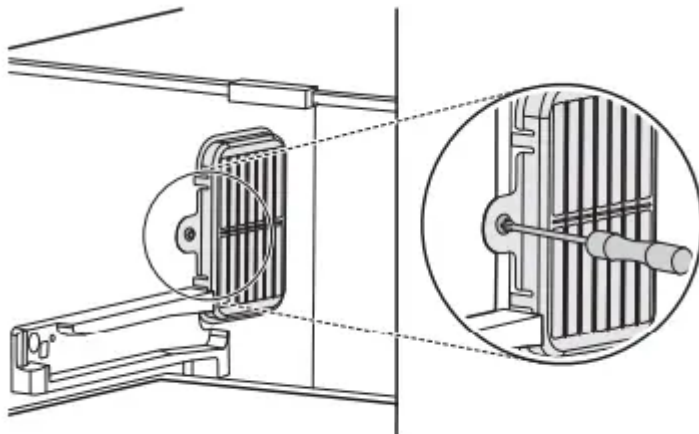

- 3** Press on the hooks at the deodorizer and then take it out.

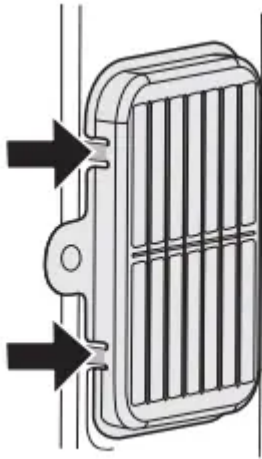

4 Dry the deodorizer by using a hair dryer or by leaving it in the sunlight.

- A natural palm wood powder is used for the deodorizer to increase deodorizing performance. Even if it falls off, it is not harmful. Wipe it off with a towel or cloth.



TROUBLESHOOTING

Before Calling for Service

Ice & Water



Symptoms	Possible Cause & Solution
<p>The automatic icemaker does not produce ice or produces a small amount of ice</p>	<p>Did you install the appliance recently?</p> <ul style="list-style-type: none"> • The ice maker produces ice normally when approximately 48 hours have passed after the appliance is installed. • If the fridge compartment temperature is too cold, the water filter can freeze and block the water flow to the ice maker.
	<p>Did you connect the water supply pipe to the appliance and open the supply valve?</p> <ul style="list-style-type: none"> • Connect the water supply pipe to the appliance and open the supply valve completely.
	<p>Is the water supply hose bent?</p> <ul style="list-style-type: none"> • If the water supply hose is bent, the water flow could be compromised.
	<p>Have you dispensed a large amount of ice recently?</p> <ul style="list-style-type: none"> • It takes approximately 24 hours to produce more ice in the automatic icemaker. Please wait.
	<p>Did you set the ice maker switch or the automatic icemaker button on the control panel to ON?</p> <ul style="list-style-type: none"> • Press I on the automatic icemaker switch or set ON for the automatic icemaker button on the control panel. (For more details on how to use, visit LG Electronics website or use your smart device.)



	<p>Is the temperature of the freezer compartment set too high?</p> <ul style="list-style-type: none"> • If the set temperature is too warm, ice will be produced slowly or not at all. <p>Set the Freezer temperature to -18 °C for normal operation of the automatic icemaker.</p>
	<p>Have you been opening the appliance door frequently?</p> <p>If you open the appliance door frequently, cold air will escape, lowering the speed of ice production. Do not open and close the appliance door frequently.</p>
	<p>Is the appliance door completely closed?</p> <p>If the appliance door is not completely closed, the temperature of the freezer compartment will increase, slowing down the ice production speed. Close the appliance door completely</p>
<p>Ice is not dispensed</p>	<p>Unable to hear the sound of ice coming out?</p> <ul style="list-style-type: none"> • In the control panel, select the modes for cubed ice and crushed ice alternately to dispense the ice
	<p>Is the ice path blocked? (You can check the ice passage by separating the ice bin.)</p> <ul style="list-style-type: none"> • Ice may not be dispensed properly if the ice passage is blocked. Check the ice and clean the ice path regularly.
<p>Water does not come out.</p>	<p>The supply valve may be turned off. (For Plumbed models Only)</p> <ul style="list-style-type: none"> • Open the water supply valve. • Check if the fridge compartment temperature is too cold, as the water filter can freeze and block the water flow to the dispenser.



	<p>The water dispenser tank may be empty. (Non plumbed models only)</p> <ul style="list-style-type: none"> • Fill the water dispenser tank.
	<p>Is the water supply valve closed? (For Plumbed models Only)</p> <ul style="list-style-type: none"> • Open the water supply valve.
	<p>Are you using unfiltered water?</p> <ul style="list-style-type: none"> • Unfiltered water can contain a large amount of various heavy metals or foreign substances, so the filter may be clogged in the early stage regardless of the life of the filter.
<p>Water tastes strange.</p>	<p>Is the taste of water different when comparing it with the taste of water from the previous water purifier?</p> <ul style="list-style-type: none"> • Has the purified water or cold water not been used for an extended period of time?
	<p>Has it been a long time since you installed and replaced the filter?</p> <ul style="list-style-type: none"> • If an expired filter is used, the purification performance may decline. It is recommended to replace the filter according to the filter replacement period.
	<p>Have you flushed out the filter properly in the initial stage after installing it?</p> <ul style="list-style-type: none"> • When you install or replace the filter for the first time, you need to remove air and activated carbon residue from inside the filter. Use the appliance after dispensing and discharging approximately 5 litres of purified water from the dispenser by pressing the water dispensing lever. (Activated carbon is harmless to humans.)



Has the purified water or cold water not been used for an extended period of time?

- The taste of old water may change due to bacterial growth. Use the product after dispensing and discharging approximately 5 litres (approximately three minutes) from the water dispenser.

Cooling

Symptoms	Possible Cause & Solution
<p>There is no refrigeration or freezing.</p>	<p>Is there a power interruption?</p> <ul style="list-style-type: none"> • Check the power of other appliances.
	<p>Check the power of other appliances.</p> <ul style="list-style-type: none"> • Plug the power plug in the outlet properly.
	<p>A fuse in your home may be blown or the circuit breaker tripped. Or the appliance is connected to a GFCI (Ground Fault Circuit Interrupter) outlet, and the outlet's circuit breaker has tripped.</p> <ul style="list-style-type: none"> • Check the main electrical box and replace the fuse or reset the circuit breaker. Do not increase fuse capacity. If the problem is a circuit overload, have it corrected by a qualified electrician. • Reset the circuit breaker on the GFCI. If the problem persists, contact an electrician.
<p>There is poor refrigeration or freezing.</p>	<p>Is the fridge or freezer temperature set to its warmest setting?</p> <ul style="list-style-type: none"> • Set the fridge or freezer temperature to a colder setting.
	<p>Is the appliance in direct sunlight, or is it near a heat generating object such as cooking oven or heater?</p> <ul style="list-style-type: none"> • Check the installation area and reinstall it away from heat generating objects.
	<p>Did you store hot food without cooling it first?</p> <ul style="list-style-type: none"> • Cool the hot food first before putting it in the fridge or freezer compartment.
	<p>Did you put in too much food?</p> <ul style="list-style-type: none"> • Maintain an appropriate space between food.



	<p>Are the appliance doors completely closed?</p> <ul style="list-style-type: none"> • Completely close the door and make sure that stored food is not obstructing in the door.
	<p>Is there enough space around the appliance?</p> <ul style="list-style-type: none"> • Adjust the installation position to make enough space around the appliance.
<p>The appliance contains a bad smell.</p>	<p>Is the fridge or freezer temperature set to 'Warm'?</p> <ul style="list-style-type: none"> • Set the fridge or freezer temperature to a colder setting
	<p>Did you put in food with a strong smell?</p> <ul style="list-style-type: none"> • Store foods with strong smells in sealed containers.
	<p>Vegetables or fruit may have spoiled in the drawer.</p> <ul style="list-style-type: none"> • Throw away rotten vegetables and clean the vegetable drawer. Do not store vegetables too long in the vegetable drawer.

Condensation & Frost



Symptoms	Possible Cause & Solution
<p>There is condensation inside the appliance or on the bottom of the vegetable drawer cover.</p>	<p>Did you store hot food without cooling it first?</p> <ul style="list-style-type: none"> • Cool the hot food first before putting it inside the fridge or freezer.
	<p>Did you leave the appliance door open?</p> <ul style="list-style-type: none"> • Although the condensation will disappear soon after you close the appliance door, you can wipe it with a dry cloth.
	<p>Do you open and close the appliance door too frequently?</p> <ul style="list-style-type: none"> • Condensation can form due to the temperature difference from the outside. Wipe out the dampness with a dry cloth.
	<p>Did you put warm or moist food inside without sealing it in a container?</p> <ul style="list-style-type: none"> • Store food in a covered or sealed container.
<p>Frost has formed in the freezer compartment.</p>	<p>Doors may not be closed properly.</p> <ul style="list-style-type: none"> • Check if the food item inside the appliance is blocking the door and make sure that the door is tightly closed.
	<p>Did you store hot food without cooling it first?</p> <ul style="list-style-type: none"> • Cool the hot food first before putting it in the fridge or freezer compartment.
	<p>Is the air entry or exit of the freezer compartment blocked?</p> <ul style="list-style-type: none"> • Make sure that air entry or exit is not blocked so that the air can circulate inside.
	<p>Is the freezer compartment overfilled?</p> <ul style="list-style-type: none"> • Maintain an appropriate space between items.

<p>Frost or condensation has formed inside or outside the appliance.</p>	<p>Did you open and close the appliance door frequently or is the appliance door improperly closed?</p> <ul style="list-style-type: none"> • Frosts or condensation can form if the outside air penetrates inside the appliance.
	<p>Is the installation environment humid?</p> <ul style="list-style-type: none"> • Condensation can appear on the exterior of the appliance if the installation area is too humid or on a humid day such as a rainy day. Wipe off any moisture with a dry cloth.
<p>The side or front of the appliance is warm.</p>	<p>There are anti condensation pipes fitted to these areas of the appliance to reduce condensation forming from around the door area.</p> <ul style="list-style-type: none"> • The heat releasing pipe to prevent condensation is installed on the front and side of the appliance. You may feel it particularly hot right after the appliance is installed or during the summer. You can be assured that this is not a problem and is quite normal.
<p>There is water inside or outside of the appliance.</p>	<p>Is there water leakage around the appliance?</p> <ul style="list-style-type: none"> • Check if the water has leaked from a sink or another place.
	<p>Is there water on the bottom of the appliance?</p> <ul style="list-style-type: none"> • Check if the water is from the thawed frozen food or a broken or dropped container.

Parts & Features

Symptoms	Possible Cause & Solution
<p>The appliance door is not closed tightly.</p>	<p>Is the appliance leaning forward?</p> <ul style="list-style-type: none"> • Adjust the front feet to raise the front side slightly.
	<p>Were the shelves properly assembled?</p> <ul style="list-style-type: none"> • Refit the shelves if needed.
	<p>Did you close the door with excessive force?</p> <ul style="list-style-type: none"> • If you apply too much force or speed when closing the door, it may remain briefly open before closing. Make sure that you do not slam the door closed. Close the door gently
<p>It is difficult to open the appliance door</p>	<p>Did you open the door right after you closed it?</p> <ul style="list-style-type: none"> • If you try to open the appliance door within one minute after you closed it, you may have difficulties because of the pressure inside the appliance. Try to open the appliance door again in a few minutes so that the internal pressure stabilizes.
<p>The inside lamp in the appliance does not turn on.</p>	<p>Lamp failure</p> <ul style="list-style-type: none"> • Close the door and re-open. If the lamp does not turn on, please contact the LG Electronics customer information centre. Do not attempt removal of the lamp.

Noises

Symptoms	Possible Cause & Solution
<p>The appliance is noisy and generates abnormal sounds.</p>	<p>Is the appliance installed on a weak floor or improperly levelled?</p> <ul style="list-style-type: none"> • Install the appliance on a solid and flat area.
	<p>Does the rear of the appliance touch the wall?</p> <ul style="list-style-type: none"> • Adjust the installation position to allow enough clearance around the appliance.
	<p>Are objects scattered behind the appliance?</p> <ul style="list-style-type: none"> • Remove the scattered objects from behind the appliance.
	<p>Is there an object on top of the appliance?</p> <ul style="list-style-type: none"> • Remove the object on top of the appliance.
<p>Clicking noises</p>	<p>The defrost control will click when the automatic defrost cycle begins and ends. The thermostat control (or appliance control on some models) will also click when cycling on and off.</p> <ul style="list-style-type: none"> • Normal Operation
<p>Rattling noises</p>	<p>Rattling noises may come from the flow of appliance, the water line on the back of the unit (for plumbed models only), or items stored on top of or around the appliance.</p> <ul style="list-style-type: none"> • Normal Operation
	<p>Appliance is not resting evenly on the floor.</p> <ul style="list-style-type: none"> • Floor is weak or uneven or levelling legs need to be adjusted. See the Door Alignment section.
	<p>Appliance with linear compressor was moved while operating.</p> <ul style="list-style-type: none"> • Normal operation. If the compressor does not stop rattling after three minutes, turn the power to the appliance off and then on again.



Whooshing noises	<p>Evaporator fan motor is circulating air through the fridge and freezer compartments.</p> <ul style="list-style-type: none"> • Normal Operation
	<p>Air is being forced over the condenser by the condenser fan.</p> <ul style="list-style-type: none"> • Normal Operation
Popping noises	<p>Contraction and expansion of the inside walls due to changes in temperature.</p> <ul style="list-style-type: none"> • Normal Operation
Vibrating	<p>If the side or back of the appliance is touching a cabinet or wall, some of the normal vibrations may make an audible sound.</p> <ul style="list-style-type: none"> • To eliminate the noise, make sure that the sides and back do not make any contact with any wall or cabinet.

Wi-Fi

Symptoms	Possible Cause & Solution
<p>Your home appliance and smartphone are not connected to the Wi-Fi network.</p>	<p>The password for the Wi-Fi that you are trying to connect to is incorrect.</p> <ul style="list-style-type: none">• Find the Wi-Fi network connected to your smartphone and remove it, then register your appliance on LG ThinQ.
	<p>Mobile data for your smartphone is turned on.</p> <ul style="list-style-type: none">• Turn off the Mobile data of your smartphone and register the appliance using the Wi-Fi network.
	<p>The wireless network name (SSID) is set incorrectly.</p> <ul style="list-style-type: none">• The wireless network name (SSID) should be a combination of English letters and numbers. (Do not use special characters.)
	<p>The router frequency is not 2.4 GHz.</p> <ul style="list-style-type: none">• Only a 2.4 GHz router frequency is supported. Set the wireless router to 2.4 GHz and connect the appliance to the wireless router. To check the router frequency, check with your Internet service provider or the router manufacturer.
	<p>The distance between the appliance and the router is too far.</p> <ul style="list-style-type: none">• If the distance between the appliance and the router is too far, the signal may be weak and the connection may not be configured correctly. Move the location of the router so that it is closer to the appliance.

Warning

This content is compiled from multiple sources and is provided for reference purposes only. It may not be complete or fully applicable to all situations. If you are unable to resolve your issue, please contact the product manufacturer or an authorized service provider for official support.

Document generated by [ManualsFile](#)