

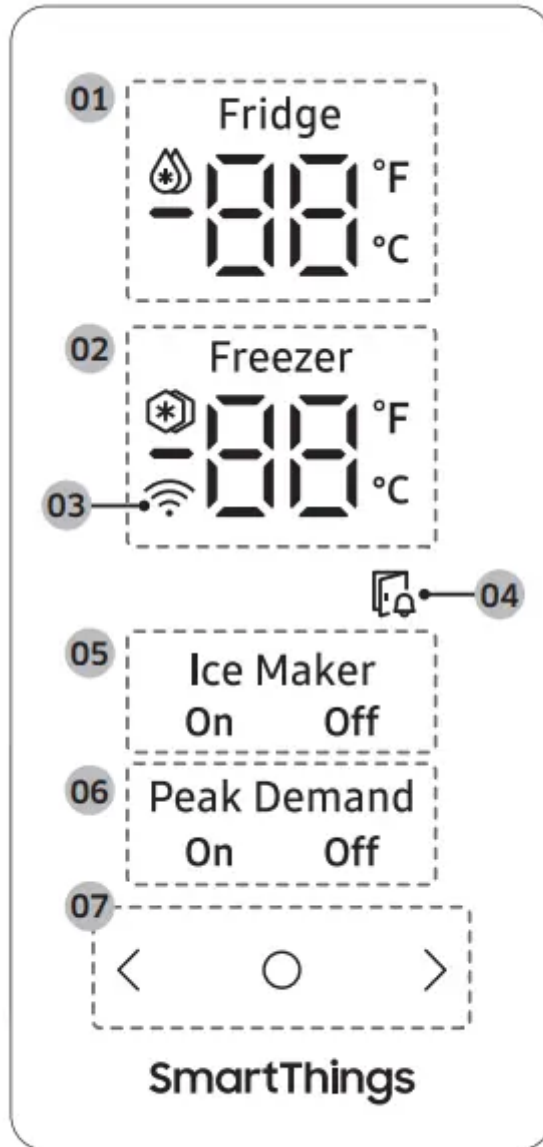





Operations

Main panel





01 Fridge indicator	<ul style="list-style-type: none"> • Displays the current or desired temperature of the fridge. •  indicates that the Power Cool function is on.
02 Freezer indicator	<ul style="list-style-type: none"> • Displays the current or desired temperature of the freezer. •  indicates that the Power Freeze function is on.
03 Network connection indicator	<ul style="list-style-type: none"> • This icon indicates that the refrigerator is connected to a network. • You can control and monitor your refrigerator on the SmartThings app. For more information, see the SmartThings section.
04 Door open indicator	This indicator blinks with an alarm if the door is left open for more than 2 minutes.
05 Ice Maker indicator	<ul style="list-style-type: none"> • Displays the status of the ice maker. • To enable ice making, you must turn on the ice maker.
06 Peak Demand indicator *	<ul style="list-style-type: none"> • Displays the status of the Peak Demand function. • For more information on the Peak Demand function, see the SMART GRID Function (Demand Response) (applicable models only) section.
07 Buttons	<ul style="list-style-type: none"> • When the display is off, tap any button to wake up the display. • Tap  to select the desired item on the main panel and to confirm any setting changes. • Tap  or  to change the settings of the selected item on the main panel.

Setting the desired temperature or function

Select the fridge or freezer and set the desired temperature or function of your choice.



1.





Tap any button ( ,  , or ) to wake up the display. - This step may not apply to some models.

2.

Tap  until the fridge or freezer indicator blinks. - The selected compartment's indicator blinks.

3.

Tap  or  to select the desired temperature or function. - Refer to the table for available selection for each compartment.

Fridge	<ul style="list-style-type: none"> Available selection (Fahrenheit):  (Power Cool) <-> 34 °F <-> 35 °F <-> 36 °F <-> 37 °F <-> 38 °F <-> 39 °F <-> 40 °F <-> 41 °F <-> 42 °F <-> 43 °F <-> 44 °F Available selection (Celsius):  (Power Cool) <-> 1 °C <-> 2 °C <-> 3 °C <-> 4 °C <-> 5 °C <-> 6 °C <-> 7 °C Power Cool speeds up the cooling process at maximum fan speed. The fridge keeps running at full speed for two and a half hours and then returns to the previous temperature.
Freezer	<ul style="list-style-type: none"> Available selection (Fahrenheit):  (Power Freeze) <-> -8 °F <-> -7 °F <-> -6 °F <-> -5 °F <-> -4 °F <-> -3 °F <-> -2 °F <-> -1 °F <-> 0 °F <-> 1 °F <-> 2 °F <-> 3 °F <-> 4 °F <-> 5 °F Available selection (Celsius):  (Power Freeze) <-> -23 °C <-> -22 °C <-> -21 °C <-> -20 °C <-> -19 °C <-> -18 °C <-> -17 °C <-> -16 °C <-> -15 °C Power Freeze speeds up the freezing process at maximum fan speed. The freezer keeps running at full speed for 50 hours and then returns to the previous temperature. To freeze large amounts of food, activate Power Freeze for at least 20 hours before putting food in the freezer. <p>NOTE: When you use this function, the energy consumption of the refrigerator will increase. Remember to turn it off when you do not need it and return the freezer to your original temperature setting.</p>



4. Wait for 5 seconds or tap  to confirm your selection.

- The selected compartment's indicator stops blinking.

Changing the temperature scale



You can switch the temperature scale between Fahrenheit and Celsius.

1.

Tap any button ( ,  , or ) to wake up the display.

- This step may not apply to some models.

2. Tap  until the °F and °C symbols on the fridge or freezer blink.

3. Tap  or  to select the desired temperature scale.



◦ Tap  to select Fahrenheit.

◦ Tap  to select Celsius.



4. Wait for 5 seconds or tap  to confirm your selection.
◦ The °F and °C symbols stop blinking.

Turning on or off the ice maker

You can turn on or off the auto ice maker in the freezer.

1. Tap any button ( ,  , or ) to wake up the display. - This step may not apply to some models.

2. Tap  until the Ice Maker indicator blinks.

3. Tap  or  to turn on or off the ice maker.









◦ Tap  to turn it on.

◦ Tap  to turn it off.

4. Wait for 5 seconds or tap  to confirm your selection.
◦ The Ice Maker indicator stops blinking.



Turning on or off the Peak Demand function

You can turn on or off the Peak Demand function. For more information on the Peak Demand function, see the SMART GRID Function (Demand Response) (applicable models only) section.

1. Tap any button ( ,  , or ) to wake up the display. - This step may not apply to some models.
2. Tap  until the Peak Demand indicator blinks.
3. Tap  or  to turn on or off the function.
 - Tap  to turn it on.
 - Tap  to turn it off.
4. Wait for 5 seconds or tap  to confirm your selection.
 - The Peak Demand indicator stops blinking.



Activating or deactivating the Sabbath mode (applicable models only)

The Sabbath mode stays active for 85 hours once it is activated. After that, it will be deactivated automatically.

- To activate or deactivate the Sabbath Mode, tap and hold  and  simultaneously for 6 seconds. Then, when the display blinks, tap  .
 - When the refrigerator is in the Sabbath mode, the buttons, display, and internal lights do not function. The refrigerator and freezer, however, continue to cool.

Activating or deactivating the Cooling Off mode

The Cooling Off mode (also called the Shop mode) is designed for retailers to display refrigerators on a retail floor. In the Cooling Off mode, the refrigerator's fan motor and lights operate normally, but the compressors do not run, so neither the refrigerator nor the freezer becomes cold.

- To activate or deactivate the Cooling Off mode, tap and hold  and  simultaneously for 6 seconds. Then, when the display blinks, press  .
 - When the Cooling Off mode is on, the refrigerator chime sounds, and the refrigerator shows "0" on the fridge indicator and "FF" on the freezer indicator.

SmartThings

Installation

- Visit the Google Play Store, Galaxy Store, or Apple App Store and search for "SmartThings". Download and install the SmartThings app provided by Samsung Electronics to your smart device.

NOTE

- The SmartThings app is not available for some tablet and iPad and some smartphone. - Support that [Android] OS 6.0 or higher. (mimimum 2 GB RAM Size) - Support that [iOS] 10.0 or higher/iPhone 6 or higher.
- For improved performance, the SmartThings app is subject to change without notice or discontinued support according to the manufacturer's policy.
- Recommended encryption systems include WPA/TKIP and WPA2/AES. Any newer or non-standard Wi-Fi authentication protocols are not supported.
- In addition, further updates on the app or the function in the app may stop due to usability and security reasons, even if updates are currently supported on your OS.
- Wireless networks may be affected by the surrounding wireless communication environment.
- If your Internet service provider has registered the MAC address of your PC or modem for identification, your Samsung Smart Refrigerator may fail to connect to the Internet. If this happens, contact your Internet service provider for technical assistance.
- The firewall settings of your network system may prevent your Samsung Smart Refrigerator from accessing the Internet. Contact your Internet service provider for technical assistance. If this symptom continues, contact a local Samsung service center or retailer.

- To configure the wireless access point (AP) settings, see the user manual of the AP (router).
- Samsung Smart Refrigerators support both IEEE 802.11 b/g/n (2.4 GHz) and 802.11 a/n/ac (5 GHz) protocols. (IEEE 802.11 n and 802.11 ac are recommended.)
- Unauthorized Wi-Fi wireless routers may fail to connect to applicable Samsung Smart Refrigerators.

Samsung account: You are required to register your Samsung account to use the app. If you don't have a Samsung account, follow the app's onscreen instructions to create a free Samsung account.

Setting started

- Turn on the device you want to connect, open the SmartThings app on your phone, and then follow the instructions below.
- If a pop-up appears saying that a new device has been found, tap ADD NOW. If a pop-up doesn't appear, tap the + button, and then select the device you want to connect from the list of available devices.
- If your device isn't in the list of available devices, tap Supported Devices, select the device type (Refrigerator), and then select the specific device model. Follow the instructions in the app to set up your device. Once setup is complete, your refrigerator will appear as a "card" on your Devices screen.

Refrigerator app

Integrated control: You can monitor and control your refrigerator at home and on the go.

- Tap the refrigerator icon on the SmartThings Dashboard or tap the Devices icon at the bottom of the Dashboard, and then tap the refrigerator "card" to open the Refrigerator page.
- Check the operation status or notifications related to your refrigerator, and then change options or settings if necessary.

NOTE: Some options or settings of the refrigerator may not be available for remote control.

Refrigerator settings

Category	Item	Description
Monitoring	Fridge temperature	Displays the desired temperature setting of the fridge.
	Freezer temperature	Displays the current temperature of the freezer.
	Diagnosis	Detects abnormal operations of the refrigerator.
	Energy monitoring	Checks the accumulated power consumption of the refrigerator for the last 180 days.
Functions	Ice making	You can turn the ice making function on or off, and check the current settings of the function. You can also check the status and progress of ice making
	Power Cool	You can turn Power Cool on or off, and check the current settings.
	Power Freeze	You can turn Power Freeze on or off, and check the current settings.
	Fridge temperature	You can set the desired temperature of the fridge.
	Freezer temperature	You can set the desired temperature of the freezer.
	Sabbath Mode	You can activate and deactivate the Sabbath mode.
Alarms	Abnormally high temperature	This alarm is triggered when the fridge or the freezer has abnormally high temperatures.
	Door opening	This alarm is triggered if the fridge door or the freezer drawer is open for a specific time.

Special features

Ice maker: The refrigerator has a built-in ice maker that automatically dispenses ice so that you can enjoy filtered water with cubed or crushed ice.

Ice Maker Operation

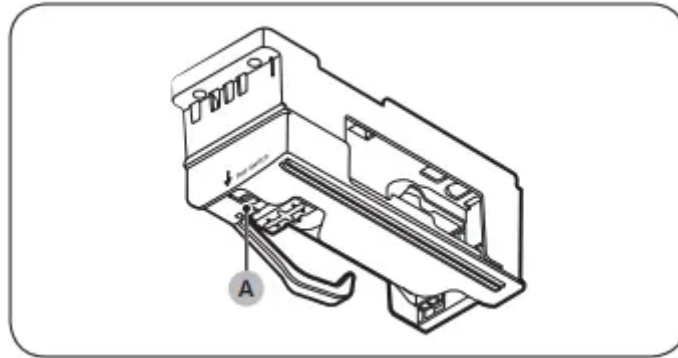

- The ice maker will produce 8 cubes per cycle - approximately 100~130 cubes in a 24-hour period, depending on freezer compartment temperature, room temperature, number of door openings, and other use conditions.
- Throw away the first few batches of ice to allow the water line to clear.
- Be sure nothing interferes with the sweep of the feeler arm. When the bin fills to the level of the feeler arm, the ice maker will stop producing ice.
- After the ice maker has been turned on again, there will be a time delay before the ice maker resumes operation.
- It is normal for several cubes to be joined together.
- If ice is not used frequently, old ice cubes will become cloudy, taste stale, and shrink. If you do not want to make ice, turn the ice maker off. (For detailed instructions on turning the ice maker on or off, see the “Turning on or off the ice maker” section on page 36.)
- If the auto ice maker does not make ice, remove the ice bucket and press Test Switch (A) to check if the auto ice maker operates properly

If You Turn the Ice Maker Off: If you turn the ice maker off, make sure to remove all ice cubes from the ice bucket. The remaining ice cubes may clump together, making it difficult to remove

Maintenance

Handling and care

Shelves

CAUTION

- The shelf must be inserted correctly. Do not insert upside down.
- Glass containers may scratch the surface of glass shelves.

Fridge shelves

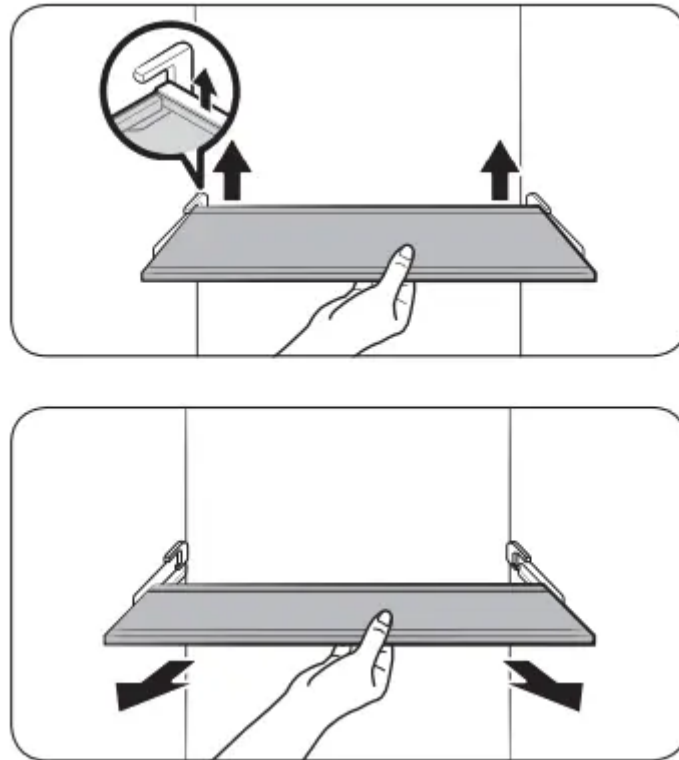

To remove a shelf, fully open the fridge door. Hold the front of the shelf and gently lift up and slide out.

1. Fully open the fridge door.
2. Hold the front of the shelf lift the back of the shelf to release the hook from the groove.
3. Pull out to remove.

Vegetable shelves

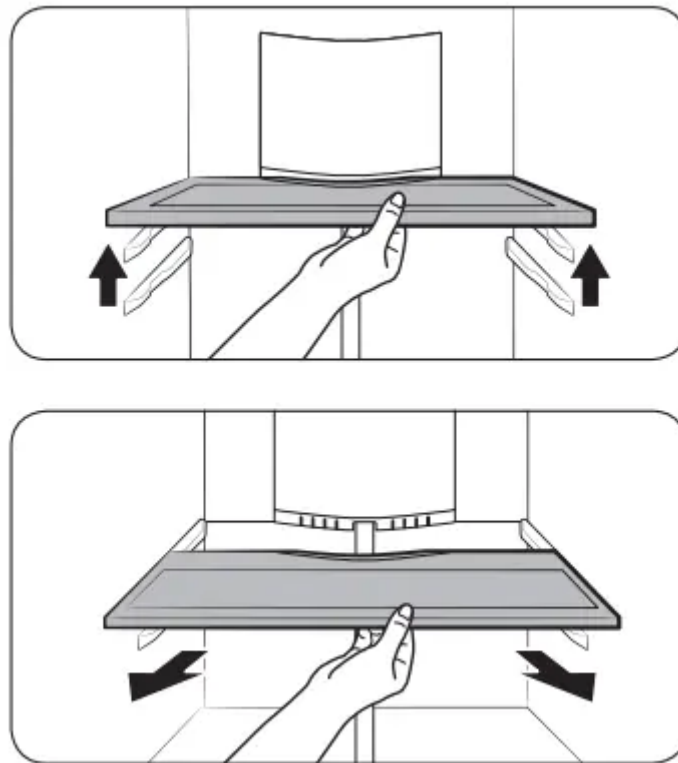

1. Fully open the fridge door.
2. Lift up the front of the shelf and pull it to release the shelf from the holder at the rear wall.
3. Pull out to remove.

Door bins

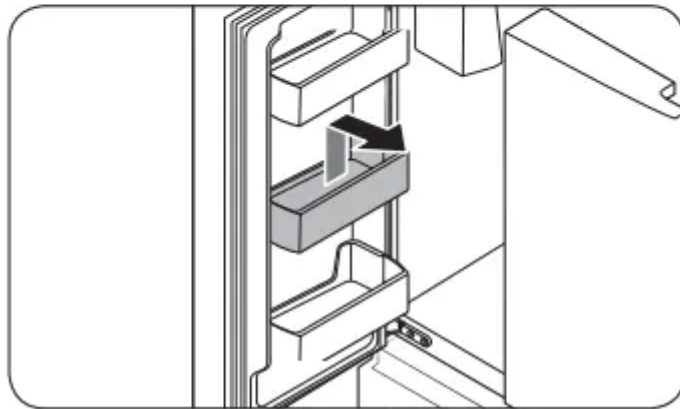
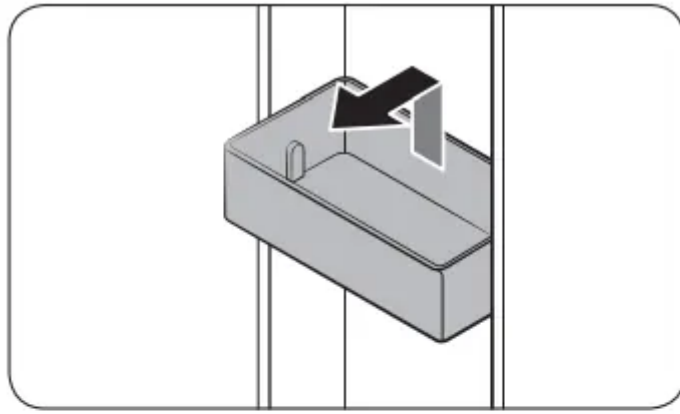

- To remove the door bin, hold the front sides of the bin, and then gently lift up to remove.
- To reinsert, insert the door bin slightly above its final location making sure that the back of the bin is against the door. Hold the rear of the door bin with both hands, and then press down so that it fits snugly

CAUTION

- Do not remove a bin that is filled with food. Empty the bin beforehand.
- Use caution when opening the door if the bottom bin contains larger bottles, which may fall over.
- Do not allow children to play with the bins. Sharp corners of the bin may cause injury.

Fridge drawers

Vegetable / fruit drawers

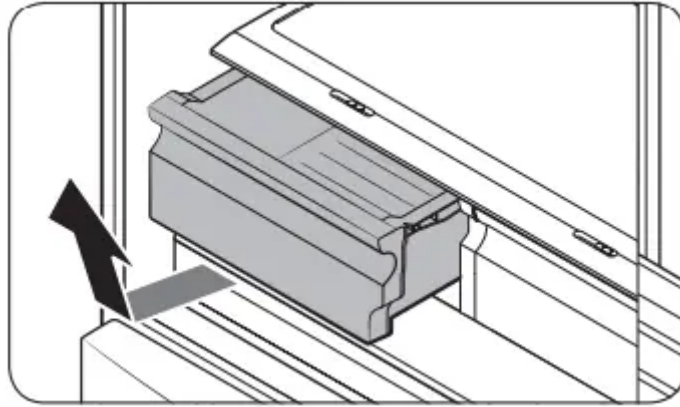

Gently lift up the front of the drawer and slide out.

- We recommend that you remove the door bins before removing the drawer. This is to prevent damage to the door bins.
- To reinsert, insert the drawer into the frame rails and then slide inward.

Freezer baskets

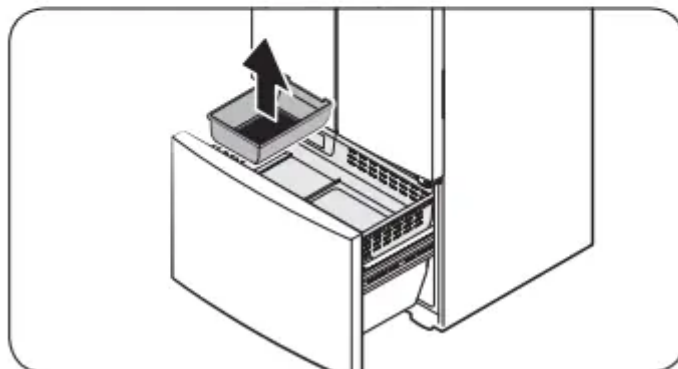
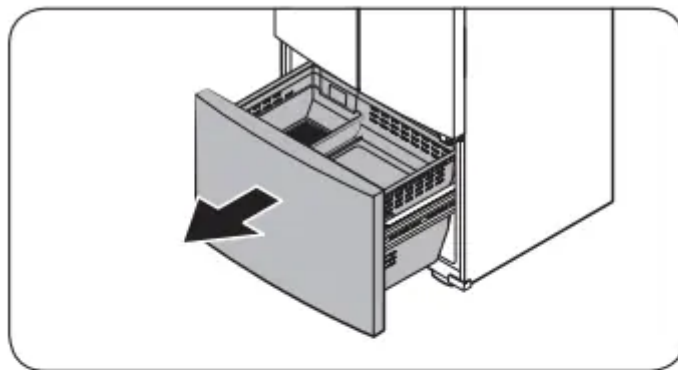

1. Fully open the freezer drawer.
2. Lift the ice bucket to remove.

Upper basket

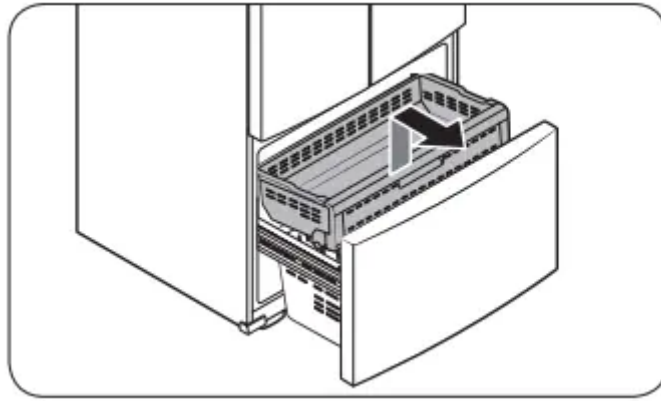

- To remove, fully slide open the freezer drawer. Lift up the front of the upper basket and pull to remove.
- To reinsert, align the front wheels of the upper basket with the end of the lower basket. Slide the upper basket to the front.

Lower basket

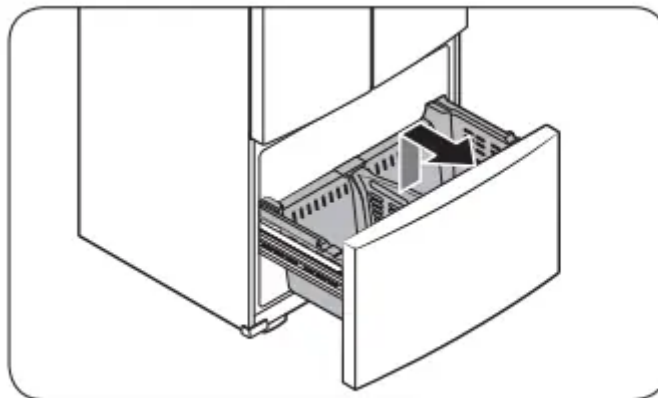

- To remove, first remove the upper basket. Then, tilt up the front of the lower basket to pull out.
- To reinsert, put the basket onto the rail assembly rear side first.

CAUTION

- Do not twist the basket when removing or reinserting the basket. The basket can be scratched.
- To prevent physical injury, property damage, or suffocation, keep children away from freezer baskets that have been removed.
- Do not remove the divider.
- Put the wheels of the upper basket on the end of the rails of the lower basket. Then, slide the upper basket all the way to the front. Otherwise, the drawer will not open or close properly, which will cause frost to build up.

Cleaning

Interior and exterior

WARNING

- Do not use benzene, thinner, home/car detergent, or Clorox™ to clean the refrigerator. They may damage the surface of the refrigerator and cause a fire.
- Do not spray water onto the refrigerator. This may cause electric shock.

Regularly use a dry cloth to remove all foreign substances such as dust or water from the power plug terminals and contact points.

1. Unplug the power cord.
2. Use a moistened, soft, lint-free cloth or paper towel to clean the refrigerator's interior and exterior.
3. When done, use a dry cloth or paper towel to dry well.
4. Plug in the power cord.

Rubber seals

- If the rubber seals of a door become dirty, the door may not close properly and reducing refrigerator performance and efficiency. Use a mild detergent and damp cloth to clean the rubber seals. Then, dry well with a cloth.

Rear panel

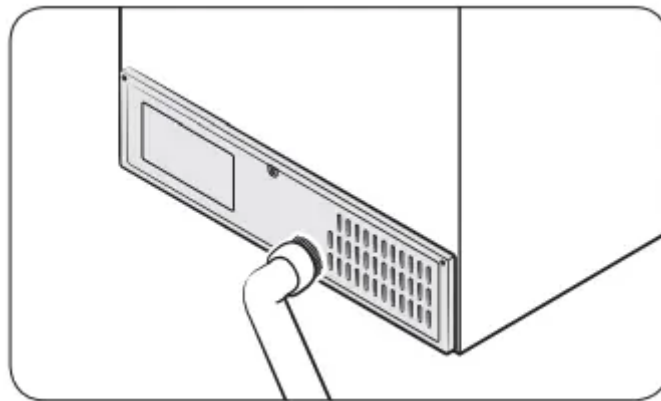

- To keep cords and exposed parts of the rear panel free of dirt, vacuum the panel once or twice a year.
- CAUTION: Do not remove the rear panel cover. Electric shock may occur.

Replacement

- LED Lamps: To replace the lamps of the refrigerator, contact a local Samsung service center.

- **WARNING:** The lamps are not user-serviceable. Do not attempt to replace a lamp yourself. This can cause electric shock.

Troubleshooting

Before calling for service, review the symptoms and recommended solutions below. If none of the suggested solutions resolve your problem, please visit our website at www.samsung.com or call Samsung Customer Care at 1-800-SAMSUNG (726-7864). Note that you will be charged for any service visits in which no defects were found.

General

Temperature

Symptom	Possible causes	Solution
Fridge/freezer does not operate. Fridge/freezer temperature is warm.	Power cord is not plugged in properly.	Properly plug in the power cord.
	Temperature control is not set correctly	Set the temperature lower.
	Set the temperature lower.	Keep the refrigerator away from direct sunlight or a heat source
	Not enough clearance between refrigerator and nearby walls or cabinets.	Make sure there is a gap of at least 2.5 inches (5 cm) between the refrigerator back and sides and any nearby walls or cabinets.
	The refrigerator is overloaded. Food is blocking the refrigerator vents.	Do not overload the refrigerator. Do not allow food to block vents.
Fridge/freezer is over-cooling.	Temperature control is not set correctly.	Set the temperature higher
Interior wall is hot.	Refrigerator has heat-proof piping in the interior wall	To prevent condensation from forming, the refrigerator has heat-proof piping in the front corners. If the ambient temperature rises, this equipment may not work effectively. This is not a system failure

Odors

Symptom	Possible causes	Solution
Refrigerator has odours.	Spoiled food Food with strong odours.	Clean the refrigerator and remove any spoiled food. Make sure strong smelling food is wrapped airtight

Frost

Symptom	Possible causes	Solution
Frost around the vents.	Food is blocking the vents.	Make sure no food blocks the refrigerator vents.
Frost on interior walls.	Door is not closed properly	Make sure food does not block the door. Clean the door gasket.

Condensation

Symptom	Possible causes	Solution
Condensation forms on the interior walls.	If door is left open, moisture enters the refrigerator. Food with high moisture content.	Remove the moisture and do not leave a door open for extended periods of time. Make sure food is wrapped airtight.

Water/ice (dispenser models only)

Symptom	Possible causes	Solution
Water flow is weaker than normal.	Water pressure is too low.	Make sure the water pressure is between 30 to 125 psi (206 to 861 kPa).
Ice maker makes a buzzing sound.	The ice maker function is activated, but the water supply to the refrigerator has not been connected	Press Ice Maker.
Ice maker does not make ice.	Ice maker has just been installed.	You must wait for 12 hours for the refrigerator to make ice.
	Freezer temperature is too high	Set the freezer temperature below 0 °F (-18 °C) or -4 °F (-20 °C) in warm ambient air.
	Dispenser Lock is activated.	Deactivate dispenser Lock.
	Ice maker is off.	Turn on the ice maker.
Ice does not dispense.	Ice may jam if the ice dispenser is not used for a long time (approx. 3 weeks)	If you won't be using the refrigerator for a long time, empty the ice bucket and turn off the ice maker.
	Ice bucket is not properly inserted.	Make sure the ice bucket is properly inserted
	Water line is not connected properly or water supply is not on.	Check if the water line is installed correctly. Check if the water line stop cock is closed.
Water does not dispense.	Water line is not connected properly or water supply is not on.	Check if the water line is installed correctly. Check if the water line stop cock is closed.
	Dispenser Lock is activated.	Deactivate dispenser Lock.
	A third-party water filter was installed.	Use only Samsung-provided or approved filters. Unapproved filters may leak and damage the refrigerator



	Water filter indicator turns on or blinks.	Replace the water filter. After replacing, reset the filter indicator sensor.
--	--	---

Do you hear abnormal sounds from the refrigerator?

Before calling for service, review the information below. If you still have questions about sounds your refrigerator is making, please call Samsung Customer Care at 1-800-SAMSUNG (726-7864). Note that you will be charged for any service visits related to normal operating sounds in which no defects were found.

These sounds are normal.

- When starting or ending an operation, the refrigerator may make sounds similar to a car engine igniting. As the operation stabilizes, the sounds will decrease.
- While the fan is operating, these sounds may occur. When the refrigerator reaches the set temperature, no fan sound will occur.
- During a defrost cycle, water may drip on the defrost heater, causing sizzling sounds.
- As the refrigerator cools or freezes, refrigerant gas moves through sealed pipes, causing bubbling sounds.
- As the refrigerator temperature increases or decreases, plastic parts contract and expand, creating knocking noises. These noises occur during the defrosting cycle or when electronic parts are working.
- For ice maker models: When the water valve opens to fill the ice maker, buzzing sounds may occur.
- Due to pressure equalizing when opening and closing the refrigerator door, whooshing sounds may occur.

SmartThings

Symptom	Action
Could not find “SmartThings” in the app market	<p>The SmartThings app is not available for some tablet and iPad and some smartphone.</p> <ul style="list-style-type: none"> • support that [Android] OS 6.0 or higher (minimum 2GB RAM Size) • support that [iOS]10.0 or higher/iPhone6 or higher
The SmartThings app fails to operate	<ul style="list-style-type: none"> • The SmartThings app is available for applicable models only. • The old Samsung Smart Refrigerator app cannot connect with Samsung Smart Home models.
The SmartThings app is installed but is not connected to my refrigerator.	<ul style="list-style-type: none"> • You must log into your Samsung account to use the app. • Make sure that your router is operating normally. • If you have not connected your refrigerator to the SmartThings App after the app was installed, you must make the connection using the device registration function of the app.
Could not log into the app.	<ul style="list-style-type: none"> • You must log into your Samsung account to use the app. • If you don't have a Samsung account, follow the app's onscreen instructions to create one.
An error message appears when I try to register my refrigerator	<p>Easy Connection may fail due to the distance from your access point (AP) or electrical interference from the surrounding environment. Wait a moment and try again.</p>
The SmartThings app is successfully connected to my refrigerator but does not run.	<ul style="list-style-type: none"> • Exit and restart the SmartThings app or disconnect and reconnect the router. • Power off the refrigerator, and then power it on again after 1 minute.

Smart Grid (applicable models only)

Symptom	Action
<p>What Do I Need to use the Energy Management and Smart Grid functions?</p>	<ul style="list-style-type: none"> • To use the Smart Grid (Demand Response) and Energy Management function on your Refrigerator, you need the following devices and apps: <ul style="list-style-type: none"> ◦ Devices: 1) A Wireless Router, 2) A SmartThings Refrigerator, 3) A Smartphone. (Recommended: Android OS 6.0 or later version) ◦ Applications: 1) “SmartThings App” from the Goolge Play Store. <p>You also need to:</p> <ul style="list-style-type: none"> • Connect the Refrigerator and the Smartphone to the same Wi-Fi network in your home. • Install and run the SmartThings App on your Smartphone. • In addition, to use the Smart Grid (Demand Response) function, you must Register for the service with your electric company. The company must have an EMS (Energy Management System) that supports SEP (Smart Energy profile).
<p>Why isn't the Energy Management function working normally?</p>	<ul style="list-style-type: none"> • Confirm that the router in your home and the internet are working properly. <ul style="list-style-type: none"> ◦ Connect a Smartphone to the router (AP, Access Point), and then confirm that you can browse the Internet on the phone. • Confirm that refrigerator is connected to the AP. <ul style="list-style-type: none"> ◦ Check for Wi-Fi icon on the panel of the refrigerator. If the refrigerator is connected, the icon will be on. • Confirm that the refrigerator and Smartphone are connected to the same router.
<p>Why isn't the Delay Defrost Capability working normally?</p>	<ul style="list-style-type: none"> • Confirm that the router in your home and the Internet are working properly. • Connect a Smartphone to the router (AP, Access Point), and then confirm that you can browse the Internet on the phone.



- Confirm that the rear where you live is properly entered into the SmartThings App.
- Confirm that the Smart Grid function works correctly. (Check the control panel. The DAL or TALR icon should not be displayed on the panel.)

Warning

This content is compiled from multiple sources and is provided for reference purposes only. It may not be complete or fully applicable to all situations. If you are unable to resolve your issue, please contact the product manufacturer or an authorized service provider for official support.