

OPERATION OF THE ICE MACHINE

The Ice Making Process

Your ice machine is unique in how it forms ice with fractional freezing to form a slab of ice that is clear and has less dissolved solids than the water it is produced from. This is accomplished by running water over the cold evaporator plate (see Figure 15) which gradually freezes the water to produce the ice slab. Pure water freezes first, leaving the dissolved solids in the residual reservoir water to provide clear ice.

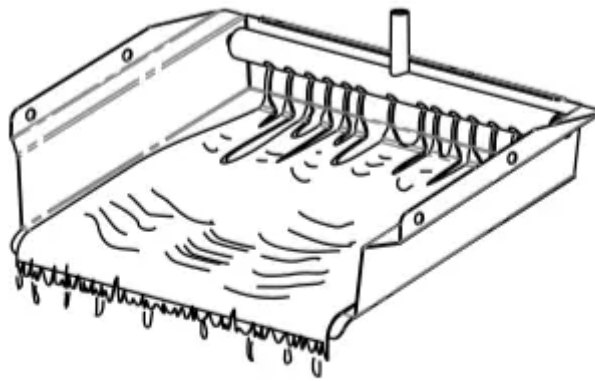

Figure 15

When the ice slab reaches the correct thickness, the ice sheet is released and slides onto the grid cutter (see Figure 17). Here, the ice slab is cut into squares by the grid cutter's heated wires (see Figure 18). The water containing the dissolved minerals is drained after each freezing cycle. Fresh water enters the machine for the next ice making cycle.

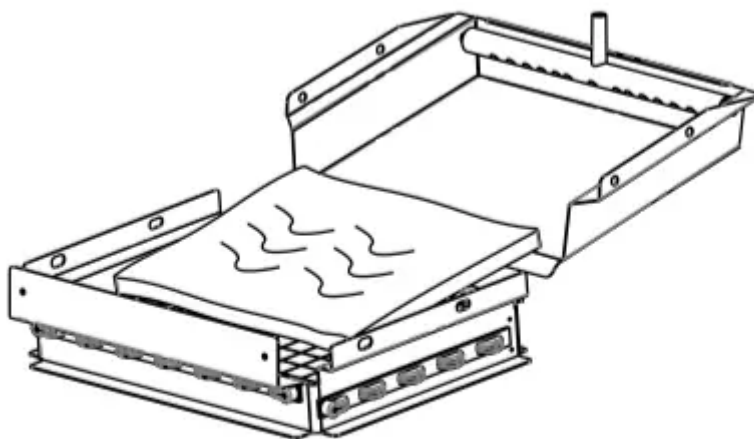

Figure 17

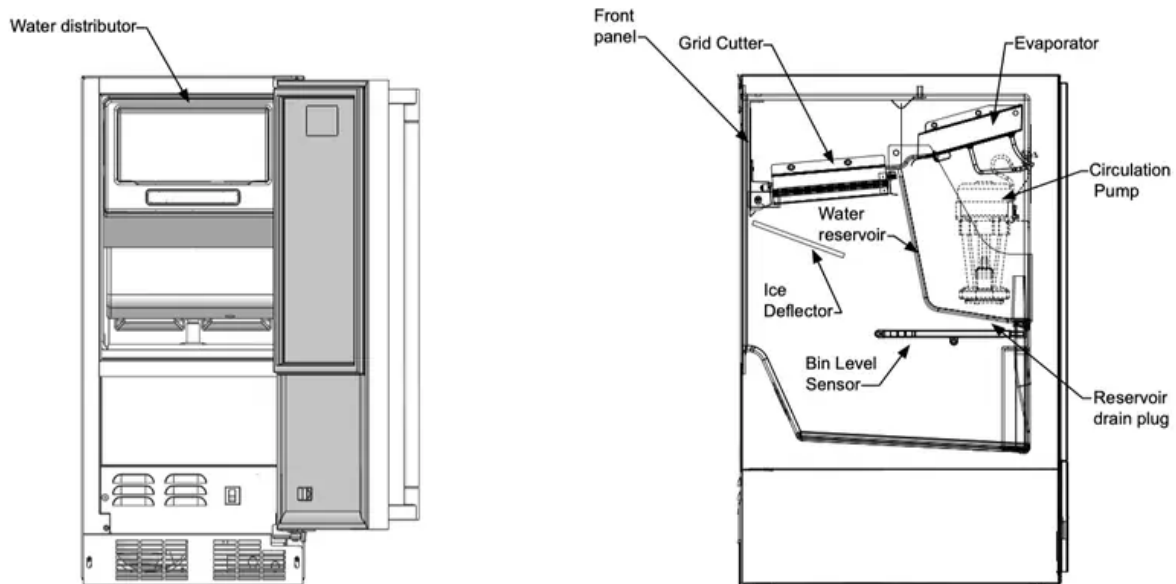

Figure 16

The ice machine will keep producing ice until the ice machine's bin is full and will restart automatically when ice needs to be replenished in the bin. The ice bin is not refrigerated, and some melting will occur by design to preserve the ice quality and clarity. Allow your ice machine to run for 24-48 hours to accumulate ice in the ice machine's bin.

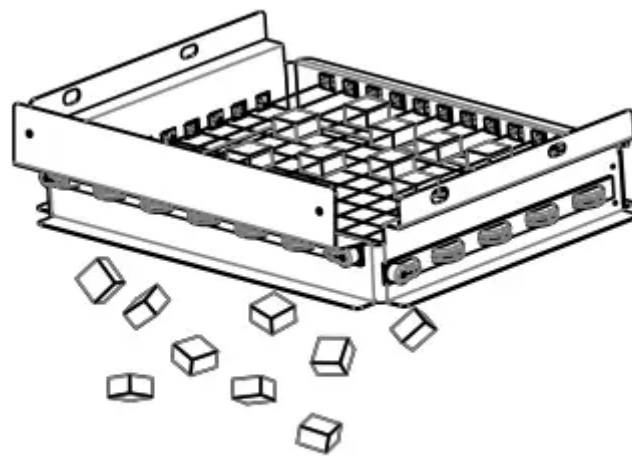

Figure 18

The bin level sensor is located in the ice bin, it senses when the ice supply is low or full and starts or stops the ice making process accordingly.

NOTE

If the water supply is turned off to the ice machine be sure to set the electronic control to the "OFF" position or remove power to the unit.



Ice Production

In normal mode the ice machine will produce up to 39 pounds (17.7 kg) of clear ice in a 24-hour period when installed in a 72°F ambient with a 55°F water supply. In "ECO" mode (see page 16) the ice machine will produce up to 29 pounds (13.2 kg) of clear ice in the 24 hour period.

NOTE

"Initial" ice production and ice accumulated in the storage bin will vary significantly. This is normal. During the first 24-hours of operation the unit will produce up to 39 lbs of ice at the above ambient and water temperature conditions, but when starting with an empty ice storage bin, the storage bin may only accumulate up to 18 lbs of ice. By design, the ice storage bin is maintained at a temperature slightly above freezing to allow the stored ice to slowly melt, to preserve the ice quality and clarity and assure a constant supply of fresh ice. As ice is accumulated in the bin, the ice production rate will overcome the ice melt and the storage bin will fill to capacity.

New Sounds

The ice machine will make sounds that are different than your household refrigerator. Because these sounds are new to you they may be of a concern but are most likely normal. The ice production process will make noises that are not typical in a refrigeration product, ice falling onto hard surfaces, water cascading across the evaporator, and valves opening and closing. Following are some of the sounds that you may hear:

A buzzing sound will be heard when the water valve opens to fill the water reservoir.

A rattling noise which could be water flowing through the water line.

A splashing sound when water is flowing over the evaporator plate and into the water reservoir.

A "thud" when the ice slab is released from the evaporator plate and slides onto the grid cutter.

"Clicks" when the cubes fall into the ice storage bin.

A gurgling sound which is refrigerant flowing in the ice machine.

An air noise from the condenser fan.

PRODUCT DIMENSIONS

MODEL	ROUGH-IN OPENING DIMENSIONS			CABINET DIMENSIONS					
	"A"	"B"	"C"	"D"	"E"	"F"	"G"	"H"	"J"
MA15C*S	15"	31 1/4" to 32 1/4"	24"	14 1/8"	31" to 32"	23 5/8"	25 1/2"	37 3/8"	16 3/8"
MA15C*P	15-1/4"	31 1/4" to 32 1/4"	24"	14 7/8"	31" to 32"	22 7/8"	-	38 3/8"	14 1/4"
ML15C*P MP15CPP	15"	34" to 35"	24"	14 1/8"	33 3/4" to 34 3/4"	22 1/8"	-	38 3/8"	14 1/4"
ML15C*S ML15C*G	15"	34" to 35"	24"	14 1/8"	33 3/4" to 34 3/4"	23 3/8"	25 1/2"	37 3/8"	16 3/8"
MO15C*S	15"	34" to 35"	24"	14 1/8"	33 3/4" to 34 3/4"	23 5/8"	26 1/8"	37 3/8"	16 3/8"
MP15CPS MP15CPG	15"	34" to 35"	24"	14 1/8"	33 3/4" to 34 3/4"	23 7/8"	26 3/8"	38 3/8"	17 1/2"

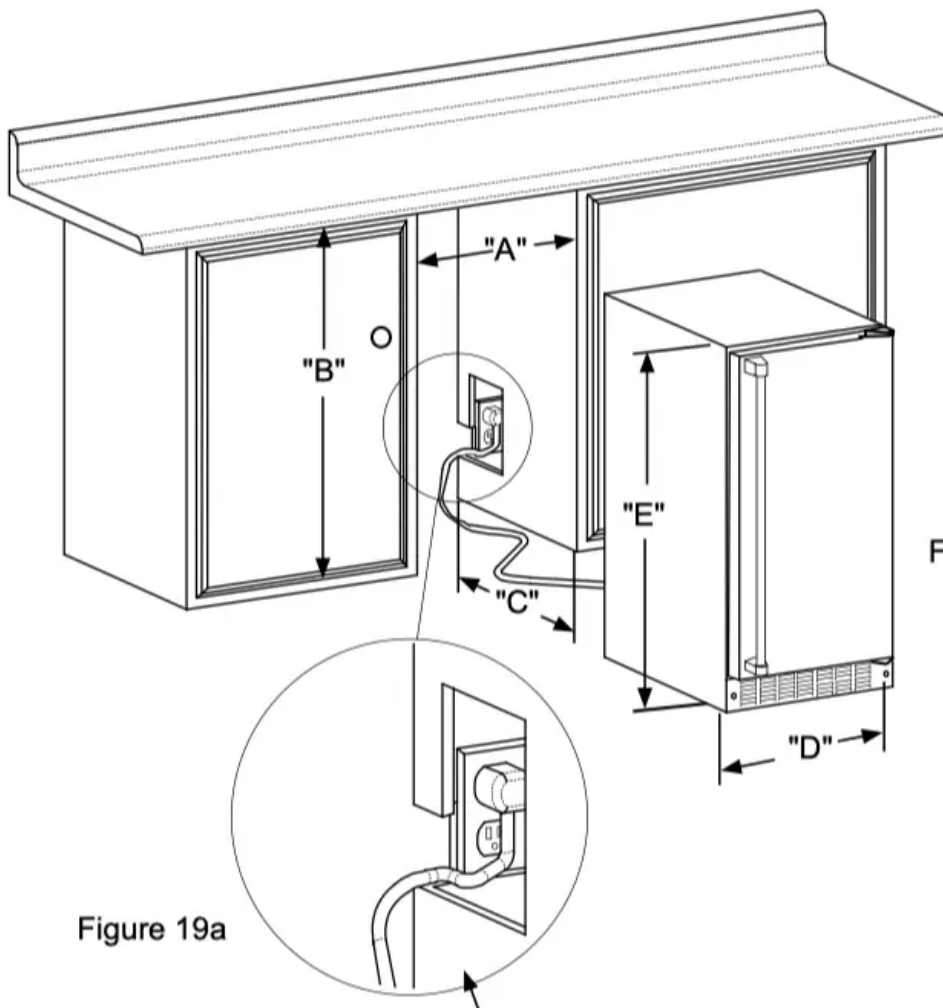

Figure 19

Figure 19a

If necessary to gain clearance inside the rough-in opening a hole can be cut through the adjacent cabinet and the power cord routed through this hole to a power outlet. Another way to increase the available opening depth is to recess the power outlet into the rear wall to gain the thickness of the power cord plug. Not all recessed outlet boxes will work for this application as they are too narrow, but a recessed outlet box equivalent to Arlington #DVFR1W is recommended for this application, (see Figure 20).



Figure 20

PRODUCT DATA		
MODEL	ELECTRICAL REQUIREMENTS #	PRODUCT WEIGHT
MA15C**	115V/60Hz/15A	100 lbs (45.5 kg)
ML15C** MO15C** MP15CP*	115V/60Hz/15A	105 lbs (47.7 kg)

** Minimum rough-in opening required is to be larger than the adjusted height of the cabinet.

A grounded 15 amp dedicated circuit is required. Follow all local building codes when installing electrical and appliance.



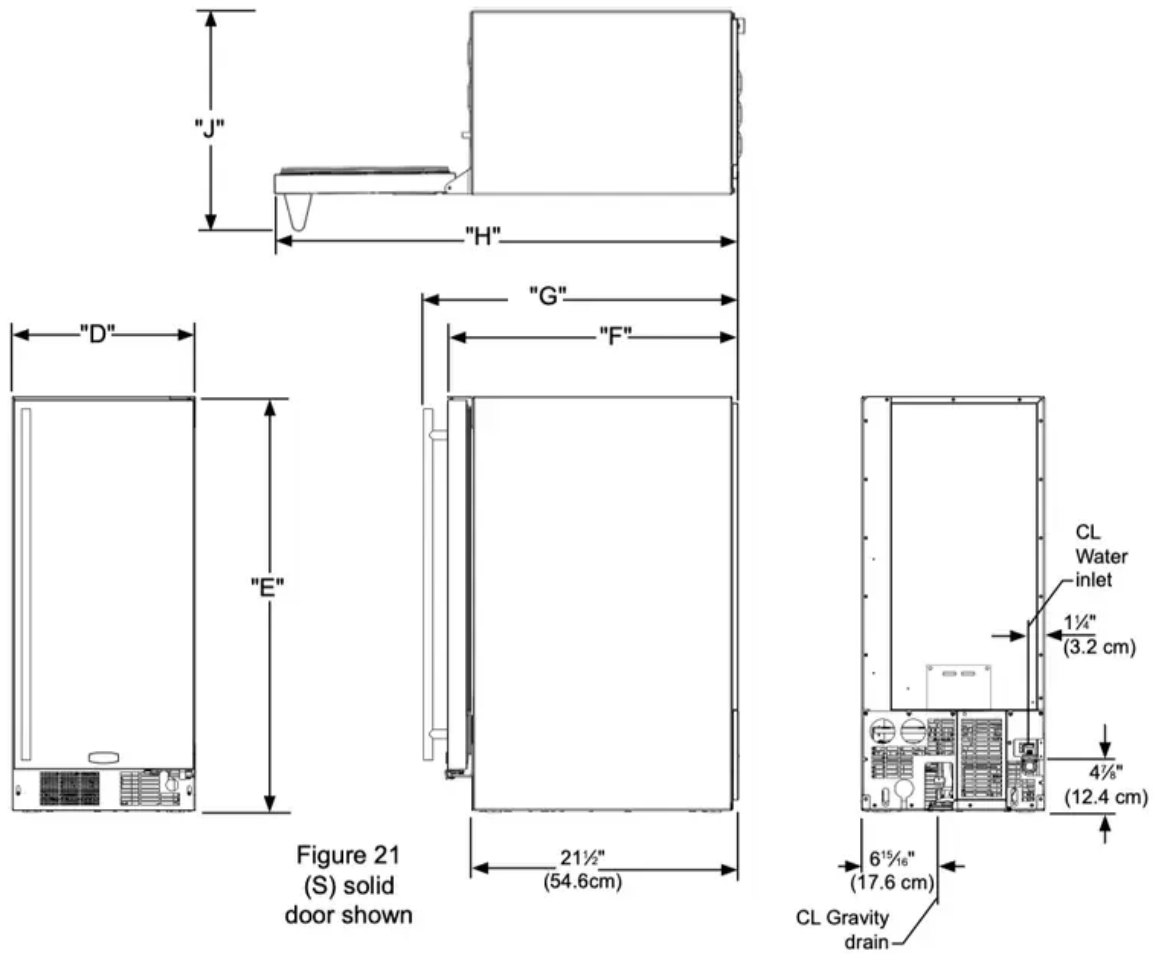

USING YOUR ELECTRONIC CONTROL



Figure 22

Display icons:



"ON/OFF" icon : used for turning the appliance on and off.



"MENU" icon : used to access optional functions in the user interface.



"LIGHT" icon: used to turn the interior light on and off, glass door models only.



"Clock" icon : used to enter the Delay start/ vacation mode.



"LOCK" icon : used to lock out functions in the user interface.

Display area text:

ICE

Signifies the appliance is on and producing ice.

ECO

Signifies the appliance is in economical ice production mode.

OFF

Signifies the appliance is off

DOOR

Signifies a door ajar alarm condition.

CLEAN

Cleaning is recommended or the appliance is in the clean mode.

Delay start/Vacation mode:

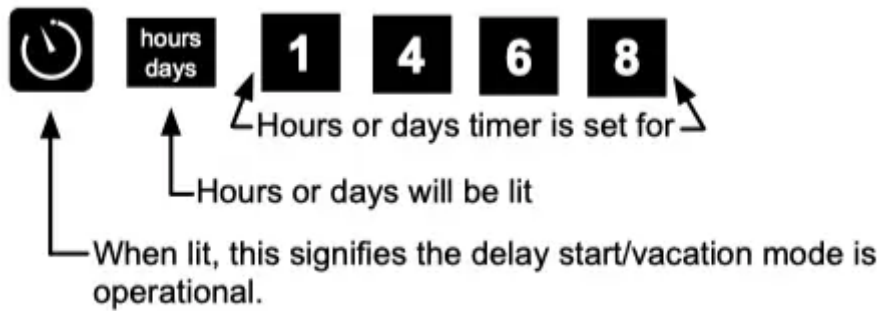

NOTE

The control display is covered with a clear plastic protective film. This film may be removed by carefully lifting at a corner.

Starting your clear ice machine:



Plug the ice machine into a 115 volt wall outlet,(see page 5 for electrical information). Your appliance is shipped from the factory in the "ICE" mode and will begin start-up of ice production after the start-up routine.

Upon applying power to the unit, or after a power interruption, the Ice machine will perform a self-test, followed by a harvest cycle to clear any in-process ice production. This start-up routine, ("after power is applied to the unit"), takes approximately 13 minutes to complete before an ice production cycle starts.

If the appliance does not start, confirm the wall outlet has power, and the control is in the "ICE" mode, (see Options section below). Do not start the ice machine in "ECO" mode. "ECO" mode should only be used after there is a full bin of ice.

Turning your ice machine On and Off:

If your appliance is on, "ICE" will be displayed. To turn the appliance off, push and hold the "ON/OFF" icon for 3-seconds. The display will show "OFF" .





NOTE

When turned off, the ice machine will complete its current ice production cycle then shut off.

The drain pump (if equipped) and the interior light will still be functioning during the OFF mode. To turn the appliance back on, press and hold the "ON/OFF" icon for 3-seconds, the display will show "ICE"

WARNING

Turning the ice machine "OFF" will only terminate the ice production, it does not remove power from the appliance. Always unplug the power cord from the wall outlet before servicing the unit.

Control Lock:



The user interface can be locked to avoid unintentional changes from things like cleaning. To lock the appliance, push and hold the "LOCK" icon for 5-seconds. The "LOCK" icon will flash 3 times, then change to steady back-lit. To unlock the user interface, press and hold the "LOCK" icon for 5-seconds, and the back-light will turn off.

NOTE

The "LOCK" icon is the only active key in this mode. If other icons are pressed while in the lock mode the "LOCK" icon will flash 3 times, and an audible tone will sound, to remind the user the appliance is in the lock mode.



Door ajar alarm:



If the door is open, or not closed properly for 5 minutes the "DOOR" indicator will illuminate and DOOR flash and an audible tone will sound. The audible alarm can be muted by pressing the "Lock" keypad.

This alarm condition can be reset by closing the door or momentarily pressing the "ON/OFF" icon, (i.e.-if you are cleaning the storage compartment, etc.). The alarm will recur in 5 minutes if the alarm condition persists.

Delay start/Vacation mode:

Your ice machine is equipped with a delay start function. This feature can be used to temporarily shut the appliance off for 1, 4, 6, or 8 hours or days. Upon completion of the selected delay period, the appliance will resume operation. This is ideal for temporarily stopping ice machine noises or to save water and electricity if you are away from home but want fresh ice upon your return.

To enter the delay start mode, press the "CLOCK" icon while the appliance is in "ICE" mode. This will delay the next harvest by the time displayed. Each additional press of the "CLOCK" icon will add time, from 1, 4, 6, or 8 hours, to 1, 4, 6, or 8 days. The next press after 8 days will leave delay set mode. After the desired time has been selected, press the "ON/OFF" icon for 2 seconds to accept, your unit will shut off and a clock icon and your selected time will be displayed. When the selected time has elapsed, normal ice production will resume.

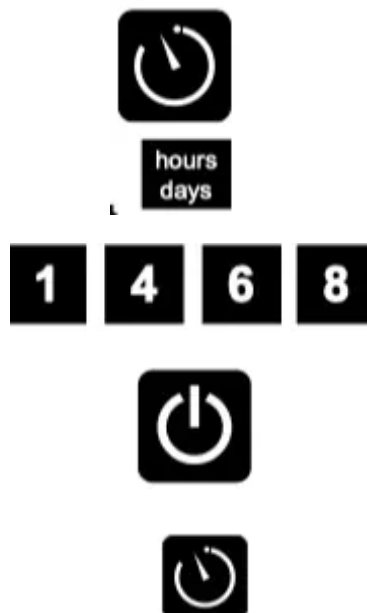

To cancel the delayed start, press and hold the "ON/OFF" icon until the appliance enters OFF, then press and hold the "ON/OFF" icon again until the appliance enters "ICE" mode.

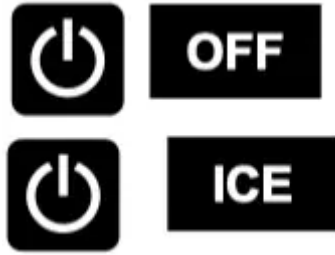

Error codes:

The ice machine is monitored continuously. Any OPEN or SHORTED circuit condition with a temperature sensor or miscommunications between the control and user interface will initiate an ERROR CODE as listed below:

Error Codes			
Error	Displayed Code	Error Description	Action to Take
Bin Sensor error	"OFF" will flash continuously in 1 second intervals in the display. No audible alarm will sound.	Failed temperature sensor. Machine operation will immediately enter an OFF state.	Call service to have the temperature sensor replaced.
System Sensor error	"ICE" will flash continuously in the display. No audible alarm will sound.	Failed condenser temperature sensor. Machine operation will continue but ice production cycle will not adapt to varying ambient conditions, so ice quality may vary.	Call service to have the temperature sensor replaced.
Communication error	Continual flashing of all indicators on the display.	Loss of communication between the main board and the user interface.	Call service to have a diagnostic check.

Options menu:

Normal and ECO mode:



Your ice machine comes with an optional "ECO" mode. This new feature allows you to tailor ice production to a conservative rate, saving approximately 25% energy and 30% water from routine operation. While in this mode ice production will slow and the appliance will use less water and electricity. "ECO" mode should only be initiated after there is a full bin of ice. To enter "ECO" mode do the following:



- Press the "MENU" icon twice and the green "ECO" will flash.
- Press and hold the "ON/OFF" icon until the green "ECO" stops flashing and remains illuminated.
- To return to the standard operating rate press the "MENU" icon twice, the ECO will turn off and the "ICE" will be flashing. Press and hold the "ON/OFF" icon until the "ICE" stops flashing and remains illuminated.



Changing the Tri-Color lighting: (MP15CP Models Only)

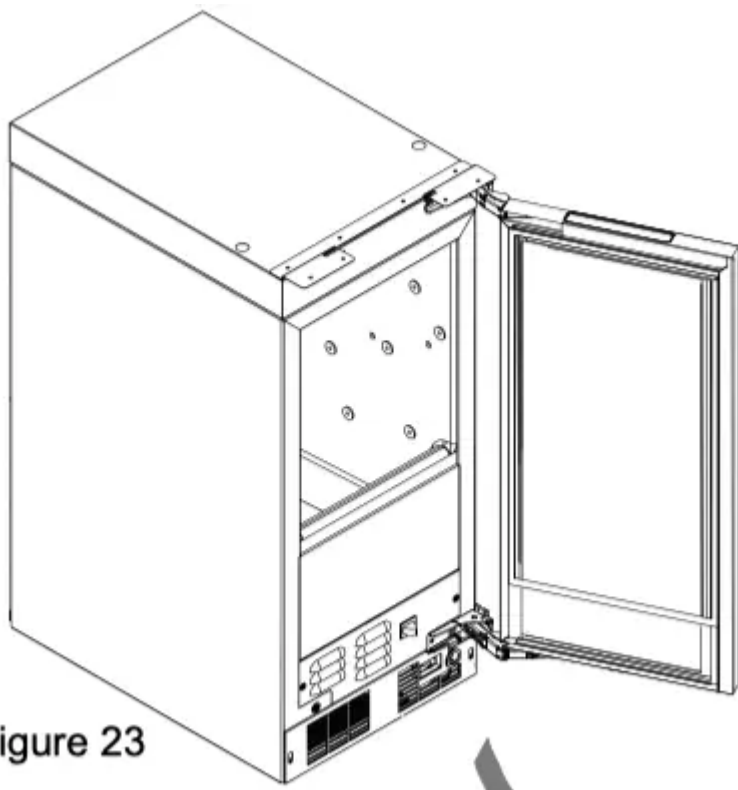

Figure 23

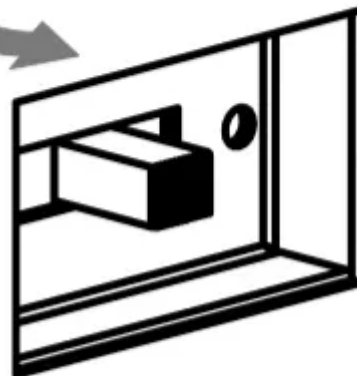

Figure 23a
Three position
slide light switch

The light switch for changing the light color is located in the toe grille. Move the switch (see Figure 23a) to the left or right to change the color of the light between blue, white, or amber.

CLEANING YOUR ICE MACHINE

Clean reminder:

CLEAN



A "CLEAN" reminder will occur every 6 months to remind you that it may be time to clean your appliance. Over time mineral build up on the cold evaporator plate can occur which can adversely affect the quality of your ice. This build-up is dependent on your water source and usage. Normal ice production will continue while the "CLEAN" reminder is displayed. You may clear the "CLEAN" reminder at any time by momentarily pressing the "ON/OFF" icon. When reset, the "CLEAN" reminder will reset and not occur for another 6 months. If you choose to clean the appliance at this time, see the options menu section below.

Clean mode:

To ensure maximum performance and ice quality, it is recommended to clean your ice machine once every six months. This simple cleaning routine will also ensure water and energy use continues at optimum efficiency.

NOTE

Homes with poor water quality or high clear ice usage might require more frequent cleaning.

To clean your ice machine you will need to purchase a "nickel safe" ice maker cleaner. Cleaner can be obtained by contacting Marvel customer service at 800-223-3900 or email orderdesk@marvelrefrigeration.

CAUTION

Use only Marvel-approved ice machine cleaner and follow all label warnings and directions. Incorrect chemical usage, and any damage that may result, is not covered by warranty.

Available to order

Clear Ice Machine Cleaner, 4-oz. bottle Part # S41013789

Once you have your cleaner:



OFF

Turn the ice machine off by pressing and holding the "ON/OFF" icon for 3 seconds. "OFF" will be displayed on the control.

Remove all ice from the ice bin (see Figure 27).

Drain the water from the water reservoir by removing the black plug from the bottom of the fresh water reservoir (see Figure 28). After the water is drained, replace the plug in the bottom of the reservoir.

Allow all of the ice to fall from the evaporator plate and remove any ice from the grid cutter. If there is ice embedded in the grid cutter wires, wait for it to melt and fall out. Do not try to remove ice that is embedded in the grid cutter wires as that may break the wires. (See Figures 24 and 25).

CAUTION

Forcing ice through the grid cutter will break the grid cutter wires.

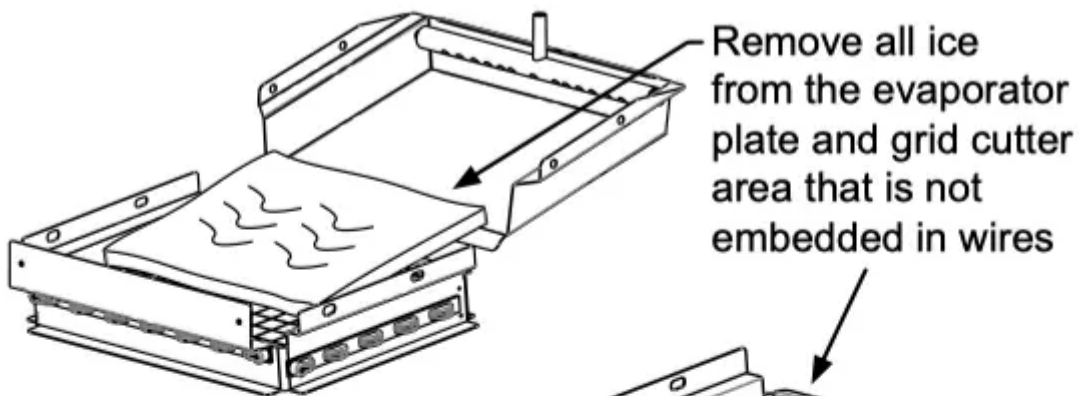

Figure 24

Figure 25



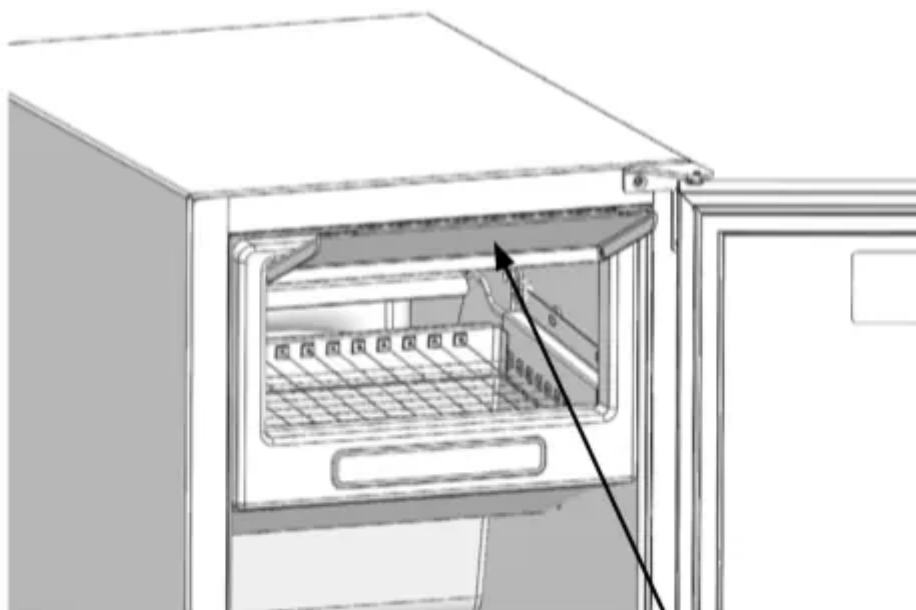

Figure 26

Lift fascia door up to
access evaporator plate

Remove all of the ice from the ice bin

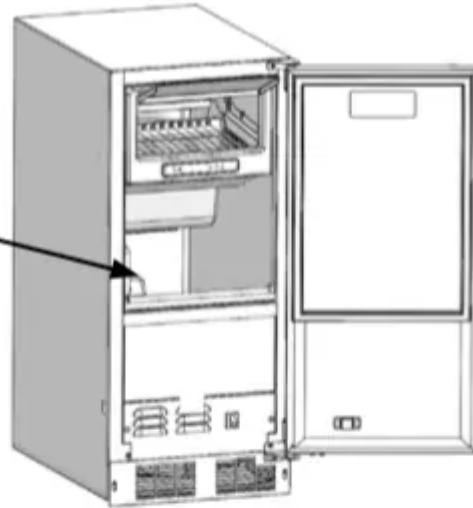

Figure 27

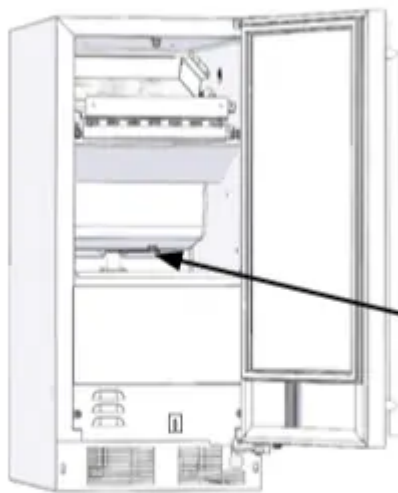

Figure 28

Remove the black reservoir drain plug from the bottom of the reservoir.

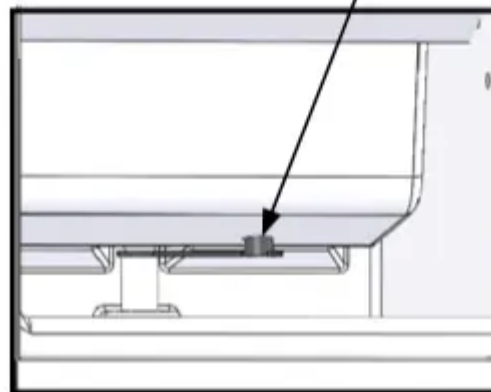

Figure 28b

Refer to your cleaning solution instructions to determine the proper amount of cleaning solution to add based on 2 quarts (1.9 liters) of water. Lift fascia door up to access evaporator plate. (See Figure 29). Pour the cleaning solution slowly on the evaporator plate so it flows down into the fresh water reservoir. (See Figure 30).

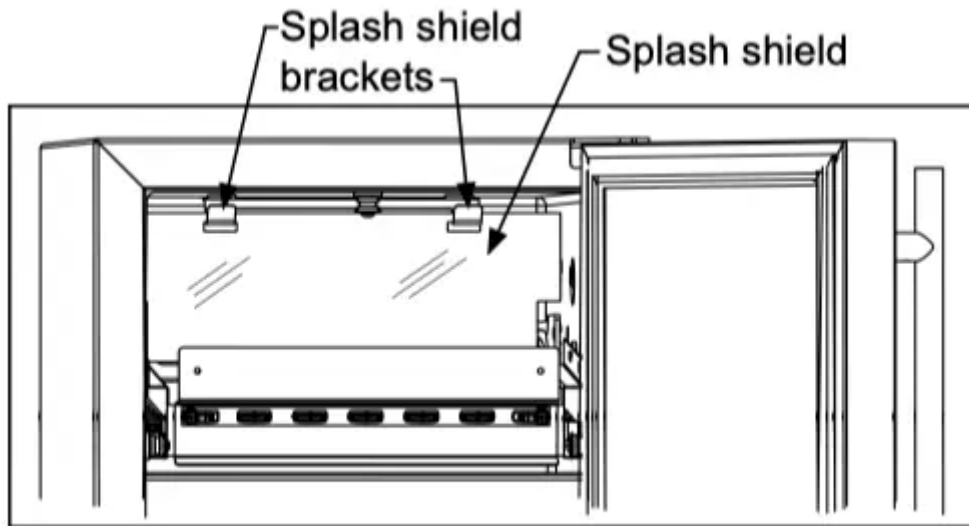

Figure 29

Replace the splash shield if removed. Turn the ice machine back on by pressing and holding the "ON/OFF" icon for 3 seconds. The display will indicate "ICE" mode. Press and hold the "MENU" icon until a flashing "CLEAN" is displayed. Press the "ON/OFF" icon until "CLEAN" stops flashing. Your ice machine will now enter the clean cycle.



The clean and rinse cycle will take about 49 minutes.

After the clean cycle is complete the ice machine will return to the "OFF" position.

After the cleaning cycle is completed, verify that all build-up has been removed. If not repeat the clean cycle procedure.

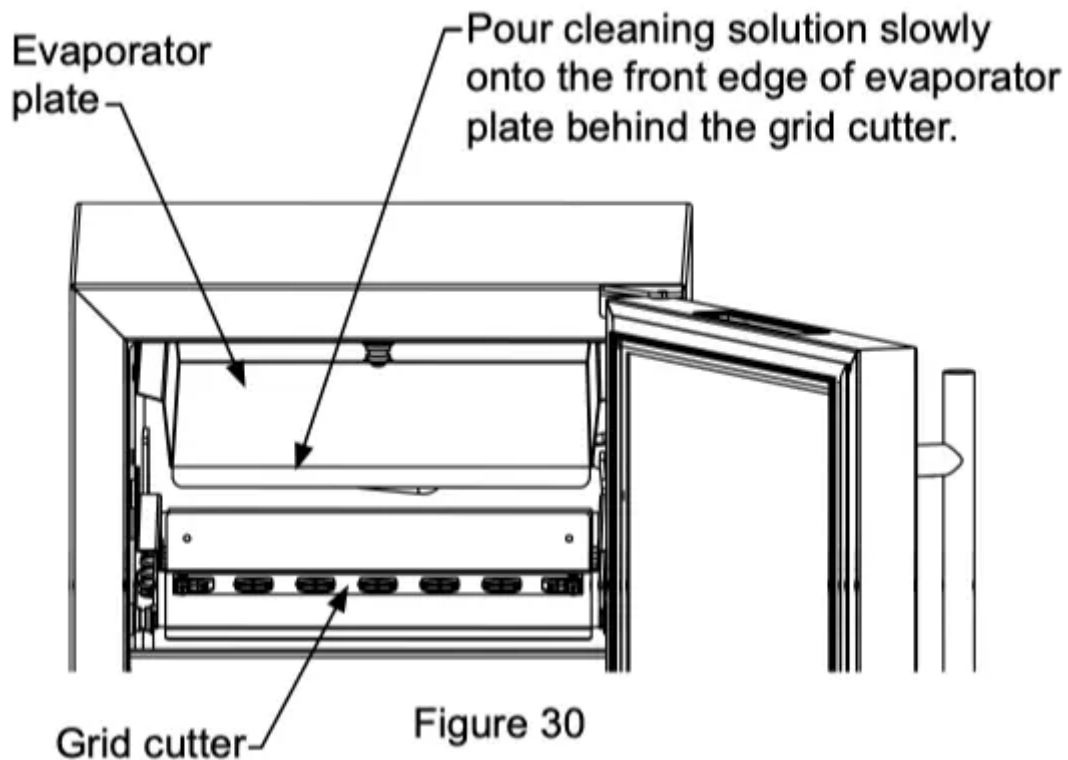

CARE AND CLEANING AND ENERGY SAVING TIPS OBTAINING SERVICE

Front Grille

Be sure that nothing obstructs the required air flow openings in front of the cabinet. At least once or twice a year, brush or vacuum lint and dirt from the front grille area (see page 4).

CAUTION

SHOCK HAZARD: Disconnect electrical power from the appliance before cleaning with soap and water.

Cabinet

The painted cabinet can be washed with either a mild soap and water and thoroughly rinsed with clear water. NEVER use abrasive scouring cleaners.

Cleaning

Routine cleaning of the stainless steel surfaces will serve to greatly extend the life of your product by removing contaminants. This is especially important in coastal areas which can expose the stainless to severe contaminants such as halide salts (sodium chloride).

It is strongly recommended to periodically inspect and thoroughly clean crevices, weld points, under gaskets, rivets, bolt heads, and any locations where small amounts of liquid could collect, become stagnant, and concentrate contaminants. Additionally, any mounting hardware that is showing signs of corrosion should be replaced.

Interior

Wash interior compartment with mild soap and water. Do NOT use an abrasive cleaner, solvent, polish cleaner, undiluted detergent or chlorine based cleaners.

Care of Appliance

1. Avoid leaning on the door, you may bend the door hinges or tip the appliance.
2. Exercise caution when sweeping, vacuuming or mopping near the front of the appliance. Damage to the grille can occur.
3. Periodically clean the interior of the appliance as needed.
4. Periodically check and/or clean the front grille as needed.

In the Event of a Power Failure

If a power failure occurs, try to correct it as soon as possible. Minimize the number of door openings while the power is off so as not to adversely affect the appliance's temperature.

Light assembly replacement

All models use LED lamps to illuminate the interior of the appliance. This component is very reliable, but should one fail, contact a qualified service technician for replacement of the LED.

Energy Saving Tips

The following suggestions will minimize the cost of operating your ice machine appliance.

1. Do not install your appliance next to a hot appliance, (stove, dishwasher, etc.). heating air duct, or other heat sources.
2. Install product out of direct sunlight.
3. Assure the front grille vents at front of the ice machine beneath the door are not obstructed and kept clean to allow ventilation for the refrigeration system to expel heat.
4. Plug your appliance into a dedicated power circuit. (Not shared with other appliances).
5. Minimize door openings and duration of door openings.
6. Set the control to the "off" position if accessing the interior to spot clean or remove large quantities of ice requires the door to be open for an extended period of time.
7. Use ECO mode if maximum ice production quantities are not required.

8. Use the delay start function if the ice machine will not be used for long periods of time.

If Service is Required:

- If the product is within the first year warranty period please contact your dealer or call Marvel Customer Service at 800.223.3900 for directions on how to obtain warranty coverage in your area.
- If the product is outside the first year warranty period, Marvel Customer Service can provide recommendations of service centers in your area. A listing of authorized service centers is also available at www.marvelrefrigeration.com under the service and support section.
- In all correspondence regarding service, be sure to give the service number, serial number, and proof of purchase.
- Try to have information or description of nature of the problem, how long the appliance has been running, the room temperature, and any additional information that may be helpful in quickly solving the problem.
- Table "C" is provided for recording pertinent information regarding your product for future reference.



For Your Records	
Date of Purchase	
Dealer's name	
Dealer's Address	
Dealer's City	
Dealer's State	
Dealer's Zip Code	
Appliance Serial Number	
Appliance Service Number	
Date Warranty Card Sent (Must be within 10 days of purchase).	

OVERLAY DOOR PANEL INSTALLATION - ML15C & MP15C MODELS

Canceling clean mode:

To exit clean mode press and hold the "ON/OFF" icon until "OFF" is displayed. Wait 3 minutes for clean mode to complete it's cancel routine before turning unit back on by pressing and holding the "ON/OFF" icon. If you turn the unit back on before the 3 minutes has elapsed, the display will show "CLEAN" and the unit will shut itself off upon completion of the 3 minute clean cancel routine.

WARNING

If you cancel clean mode after adding ice maker cleaner, you must re-start cleaning and allow clean cycle to complete to remove the cleaning solution before resuming ice production.

Optional: After the cleaning cycle has been completed , you may wash the interior with a mild detergent / dish soap or a solution of two tablespoons of baking soda and one quart of water. Rinse with clean water.

Replace the grid cutter cover.

Do not use bleach based cleaners or any abrasive cleaning products. Chlorine based cleaners will attack the stainless steel, making it susceptible to corrosion.

Your ice machine is now ready to restart. Press and hold the "ON/ OFF" icon for 3 seconds until "ICE is displayed.



After cleaning it is recommended you discard the ice produced after 3 hours of ice production.

If you purchased an overlay panel model, your unit is equipped with articulated hinges to allow fully integrated built-in installations. Custom panel thicknesses of 5/8 " (15 mm) and 3/4 " (18 mm) are accommodated.

CAUTION

It is important to use the factory provided grille that came with the product to assure proper air flow is maintained through the condenser. The use of a custom grille is not recommended and will void the warranty.

WARNING

Overlay panel models are designed for use with built-in installations only. Use in freestanding installations could result in personal injury.

Step 1: Removing the Door

With a phillips screwdriver remove the screw and "P" clamp from the bottom of the door near the hinge. See Figure 31b.

Disconnect the door wire harness by pressing and holding down the locking tab on the wire connector and pulling the connector apart. See Figure 32.

Open the door and loosen the screws holding the hinges to the cabinet (2 at the top and 2 at the bottom hinge). Do not remove the screws but loosen them enough so the hinges can be slipped off of the screws when sliding the door to the side.

WARNING

The articulated hinges have many pinch points. Carefully close / collapse the hinges as soon as the door is removed from the cabinet.

With a helper, and being careful not to scratch the cabinet or the door, slide the door to the side about 1/2 inch and remove the hinges and door from the unit.

WARNING

Use extreme caution with the articulated hinges. The hinge is self closing and many pinch points exist prior to built-in installation. Do not remove the cabinet "Z" bracket from the top of the cabinet.



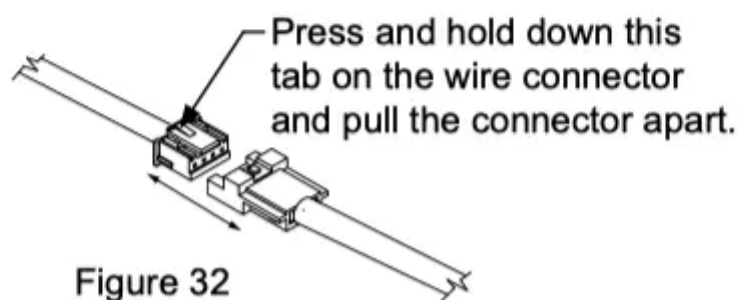
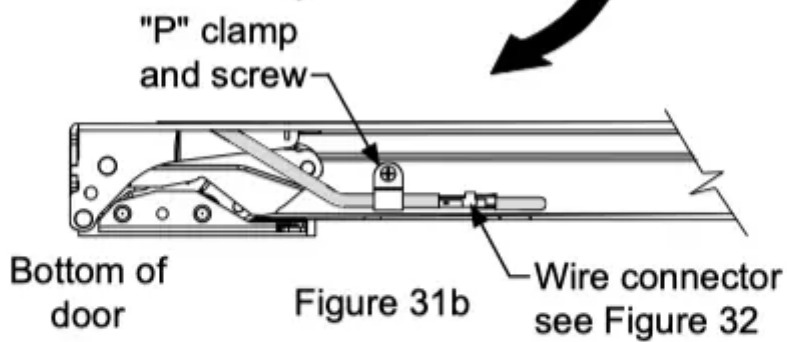
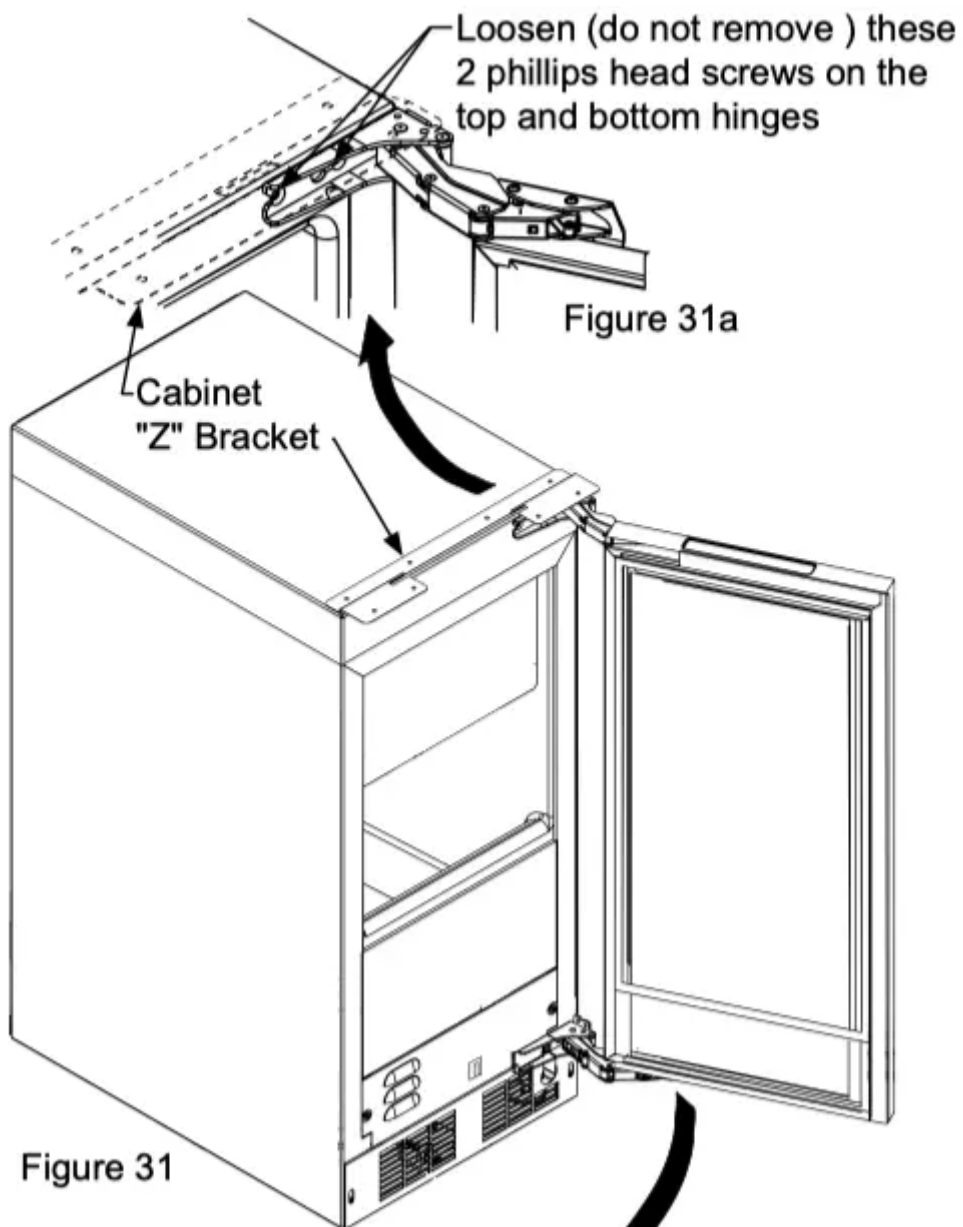

Step 2: Remove the door gasket

With the door laying on a flat surface and starting at a corner of the door remove the magnetic door gasket from it's retainer by pulling it away from the interior side of the door, see Figure 33. Set the gasket aside on a flat surface.

There are 10 holes in the gasket retainer extrusions, (3 on each side and 2 at the top and bottom which are used to fasten the panel to the front of the door. The screws are provided in the literature pack.

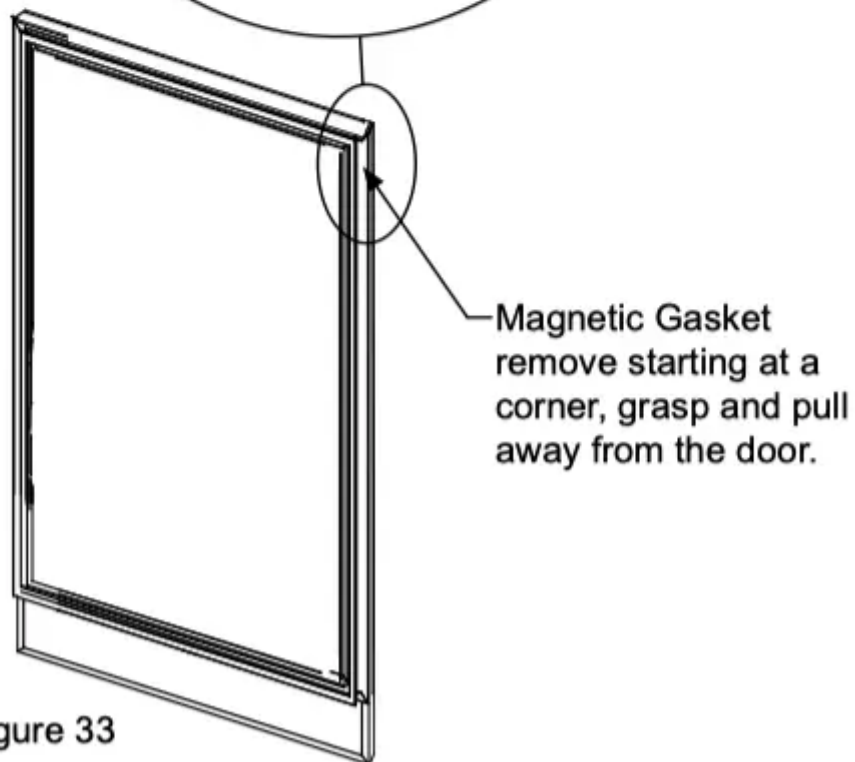
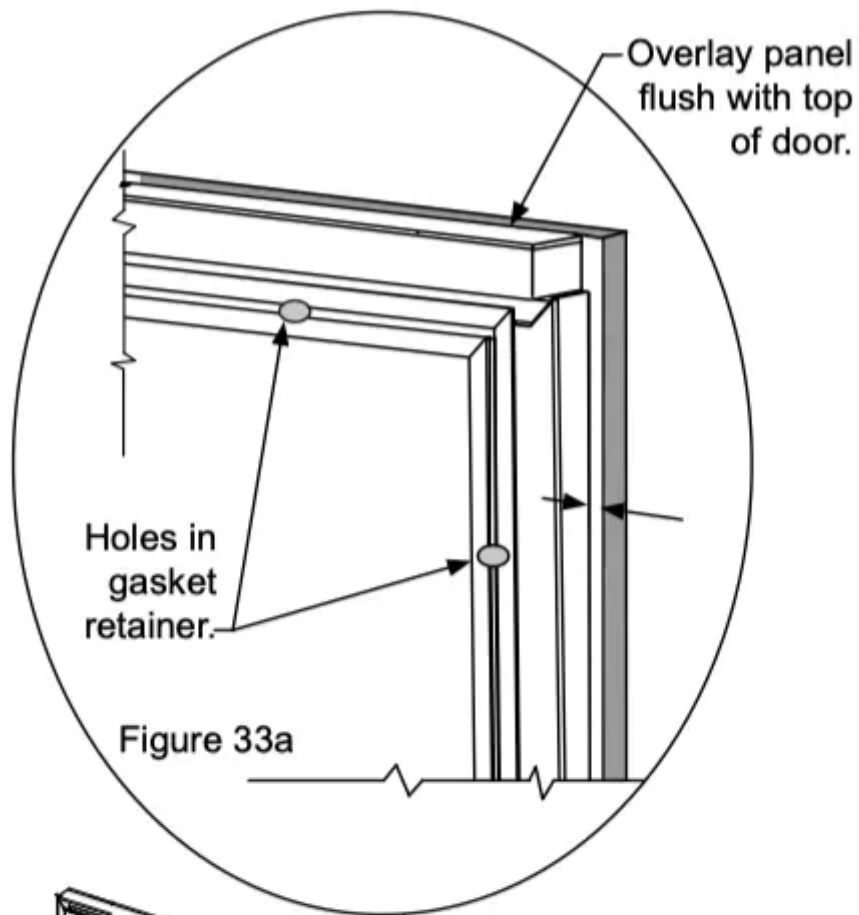

CAUTION

Weight of overlay door panel must not exceed 15 pounds (6.8 kg).

Step 3: Cut and drill the overlay panel



Depending on your model cut the overlay door panel to the dimensions shown in Figures 34 to 37.

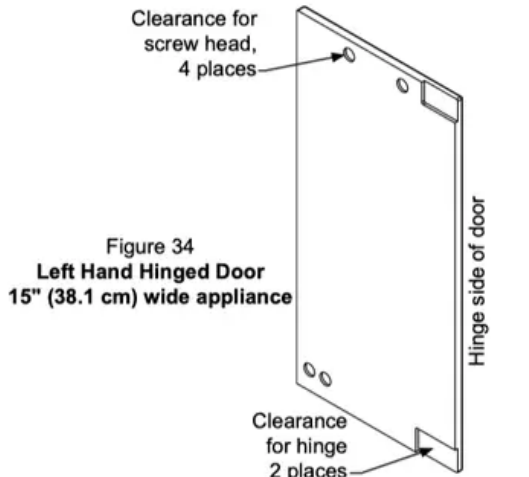

Figure 34
Left Hand Hinged Door
15" (38.1 cm) wide appliance

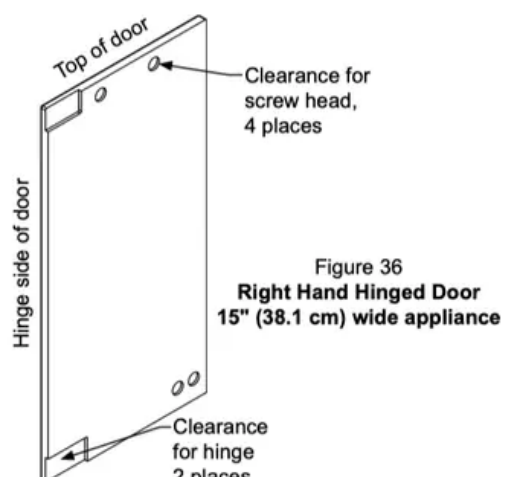

Figure 36
Right Hand Hinged Door
15" (38.1 cm) wide appliance

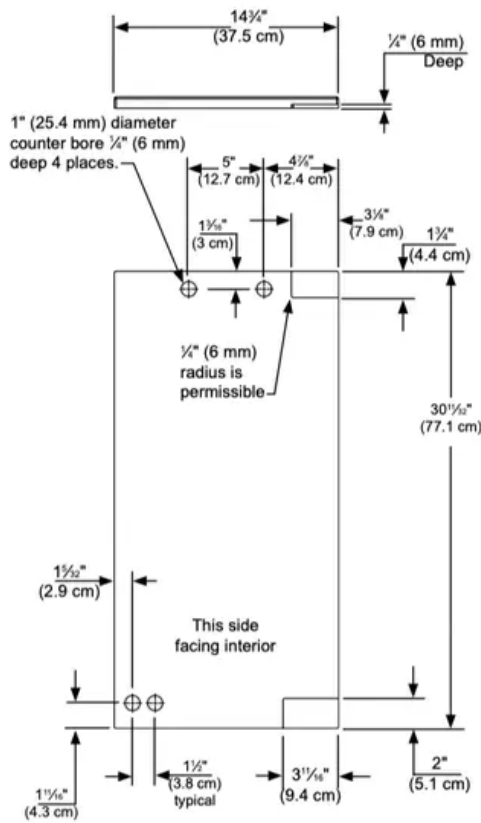

Figure 35
Left Hand Hinged Door
15" (38.1 cm) Wide Appliance

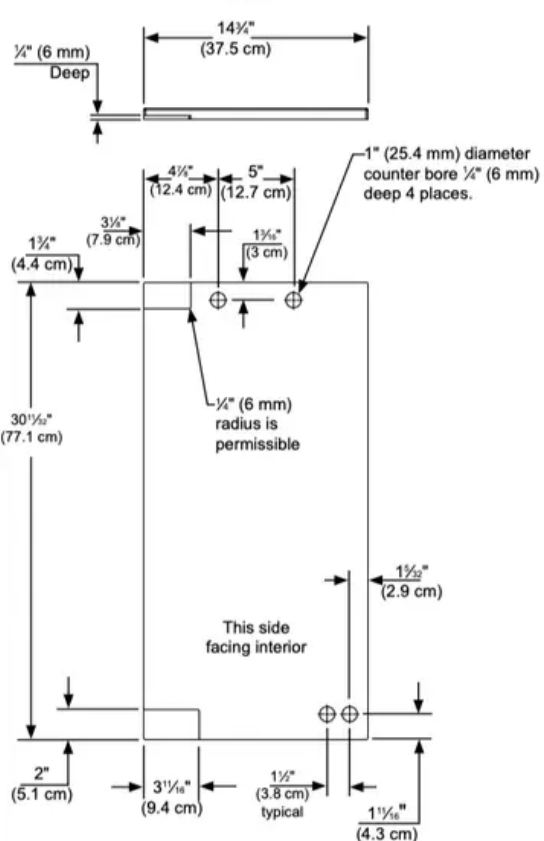

Figure 37
Right Hand Hinged Door
15" (38.1 cm) wide appliance

Step 4: Assemble the panel to the door

The preferred method of attaching the panel to the door is to clamp the panel to the door so it cannot move while drilling the screw pilot holes. Use bar clamps or "C" clamps with pads on the clamping surfaces that will not mar the panel or the door. The custom overlay panel should be flush with the top of the door and centered along the width of the door. See Figure 33a. Drill holes through the gasket extrusion using the 10 holes as pilot holes. Use the drill size from the chart in Table "B", being careful not to drill through the front surface of the panel. If the overlay panel is thinner than 5/8" (16 mm) thick shorter screws will have to be obtained. Fasten the panel to the



door with the 10 screws provided in the literature pack. (See Figure 38). Remove the clamps and replace the gasket in the gasket extrusion channels of the door. Some force may be required to seat the gasket into the channels. Be sure the gasket corners are seated properly.

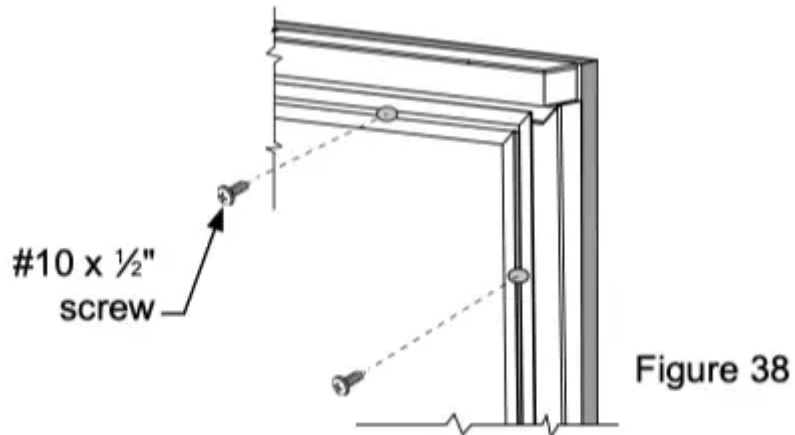

Step 5: Install the door

Carefully open the top and bottom hinges on the door being careful as there are many pinch points. Place the hinges over the 4 screws in the cabinet, 2 at the top and 2 at the bottom and slide the door into position. Tighten the 4 hinge screws with a phillips screwdriver. (See Figures 31 and 31a). Place wire harness from the grille and mount to the bottom of the door with the screw and "P" clamp removed in step 1. (See Figure 31b). Reconnect the wire harness, (See Figure 32).

Step 6: Secure the cabinet

Use the #8 x 3/4 " black screws from the literature pack to secure the counter top to the cabinet top through the holes in the cabinet "Z" bracket.

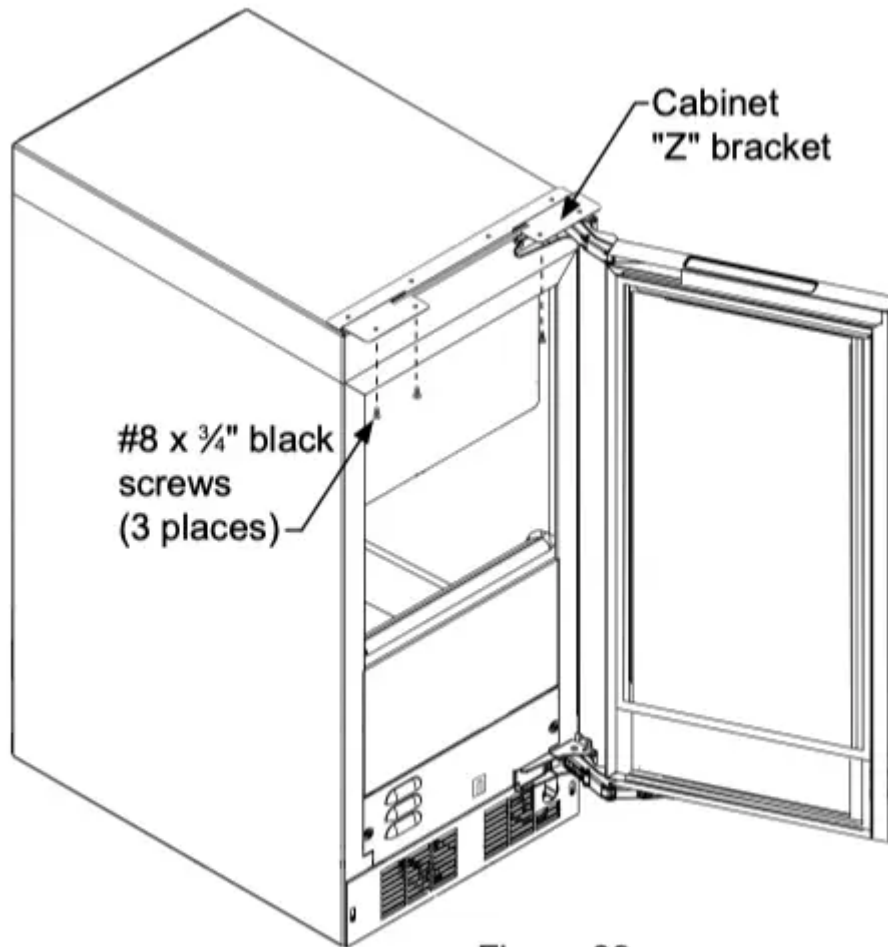
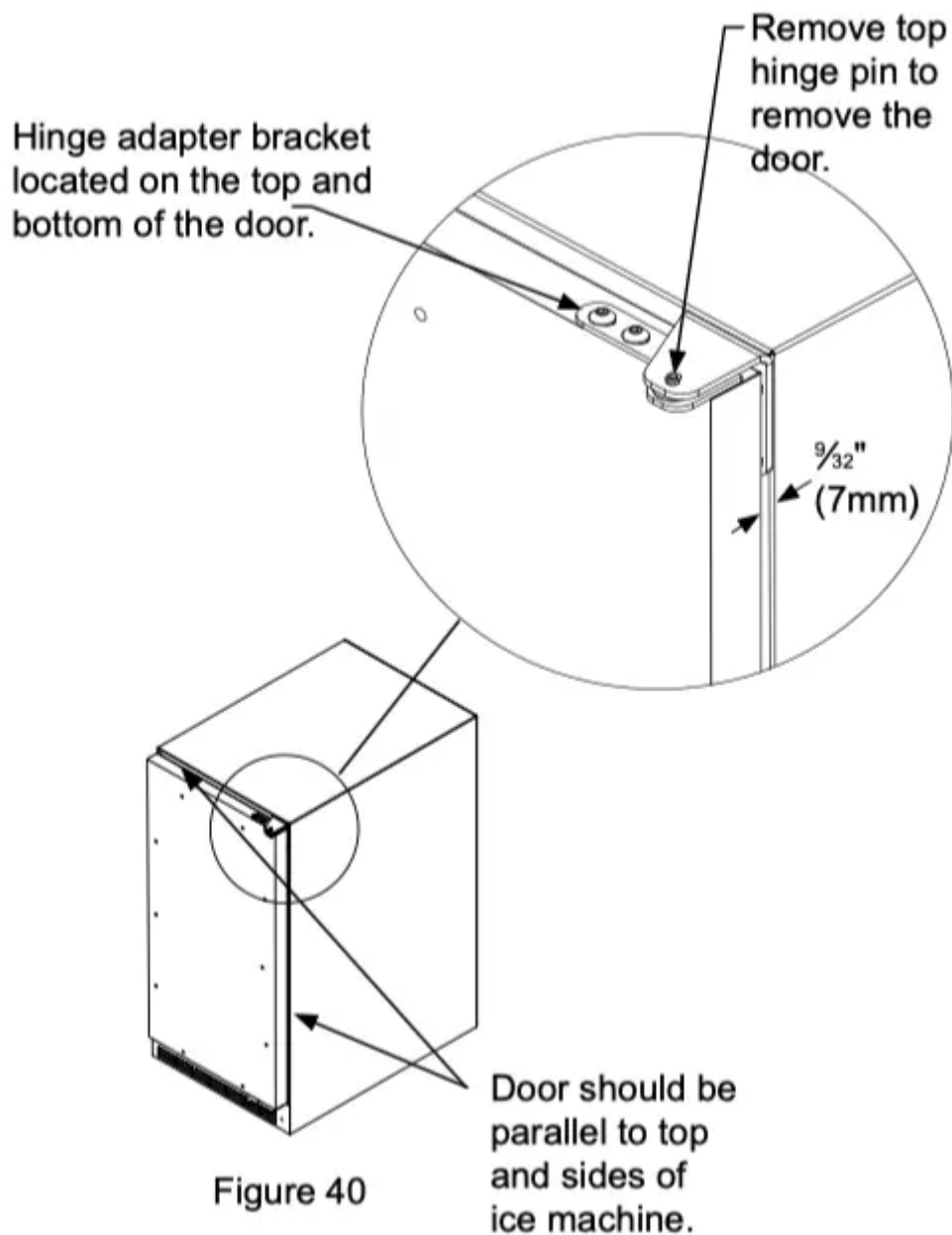

Figure 39

CAUTION

Step 1: Verify door alignment

Verify that the door is aligned correctly with the cabinet prior to fabricating the custom panel. Failure to do so may result in mis-alignment of the custom panel with the hinge bracket. The door should be parallel to the sides and top of the ice machine. If alignment is necessary the door may be adjusted by loosening the 2 screws which secure the top and/or bottom hinge adapter brackets, located on the top and bottom of the door and adjusting the door side to side. Use a 5/32 " allen wrench, for this procedure. (See Figure 40 below). When finished aligning the door, tighten the screws securely.



Step 2: Remove door

Remove the top hinge pin from the hinge with an 1/8" allen wrench. Remove the door by angling the top of the door outward and lifting the door off the bottom hinge.

(See detail in Figure 40).

Step 3: Remove gasket

Lay the door on its front being careful not to scratch it. To gain access to the screw mounting holes remove the door gasket by peeling up and out of the channel.

NOTE

For the door to work properly it is necessary to maintain a minimum space of $\frac{9}{32}$ " (7mm) between the door and cabinet flange as shown . This space can be adjusted by adjusting the top and bottom hinge adapters.

Step 4: Cut overlay panel

Depending on the ice machine model cut the overlay panel to the dimensions shown in Figure 41 for a right hand hinged door or Figure 42 for a left hand hinged door. The 2 slots at the top and bottom are required for clearance of the hinge pins and can be made with a router and $\frac{3}{8}$ " (9.5 mm) diameter router bit.

CAUTION

Weight of the overlay panel should not exceed 20 pounds (9.1 kilograms).

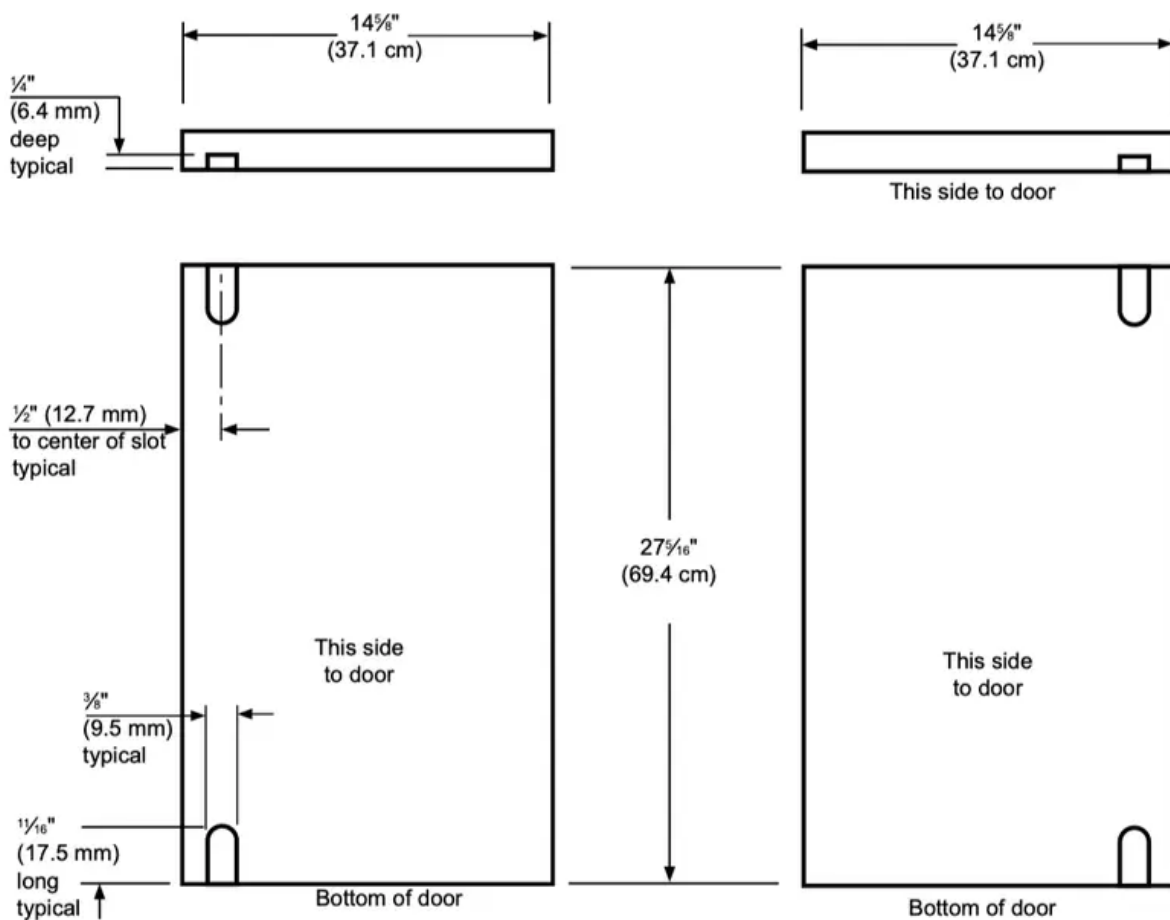

Figure 41
Panel dimensions for
a right hand hinged door

Figure 42
Panel dimensions for
a left hand hinged door

Step 5: Drill necessary handle holes and mount handle:

This is a convenient time to locate and drill the holes for your handle. Most often the handle is to match that of the surrounding cabinetry. If your handle attaches from the back-side of the custom panel, locate the mounting holes while the panel is attached to the door and cabinet. After the panel is removed from the door, drill the mounting holes from the front, to the recommended



diameter of the handle manufacturer. Counter bore the back-side of the panel so the screw heads do not interfere with the surface of the door.

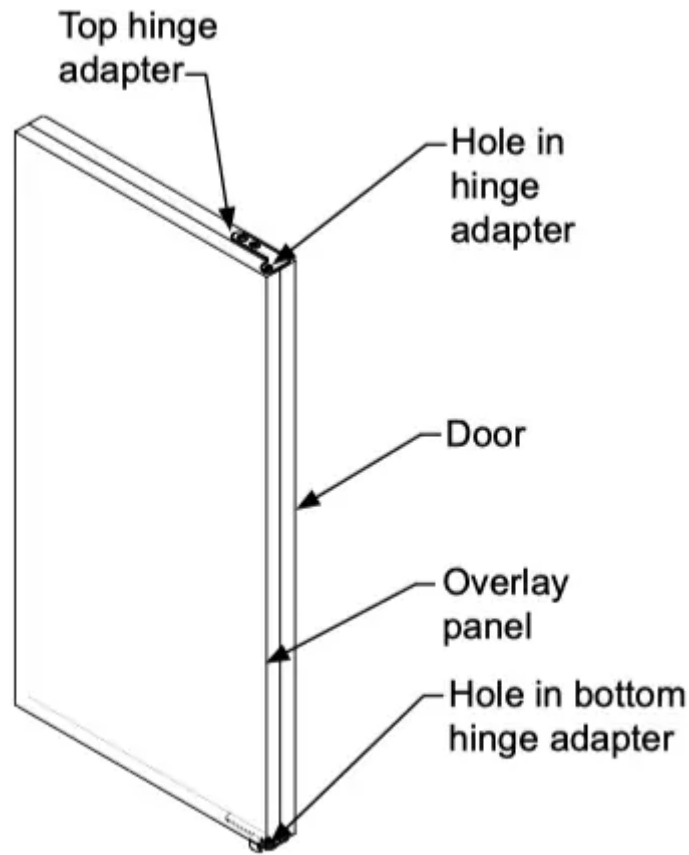

Figure 43

Step 6: Drill panel mounting holes

Re-clamp the panel to the door per step 5 and drill the screw pilot holes for attaching the overlay panel to the door. Select the size of the hole from Table A. Be careful not to drill the pilot holes through the overlay panel, 1/2 " (12.7 mm) deep for 3/4 " (19 mm) and 5/8 " (15.7 mm) panels.

Step 7: Secure overlay panel to the door.

With the #10 wood screws provided, fasten the overlay panel to the door. (See Figure 44).



Material Type	#10 Wood Screw
Hardwood	1/8" (3.2 mm) Diameter Pilot Hole
Softwood	7/64 (2.8 mm) Diameter Pilot Hole

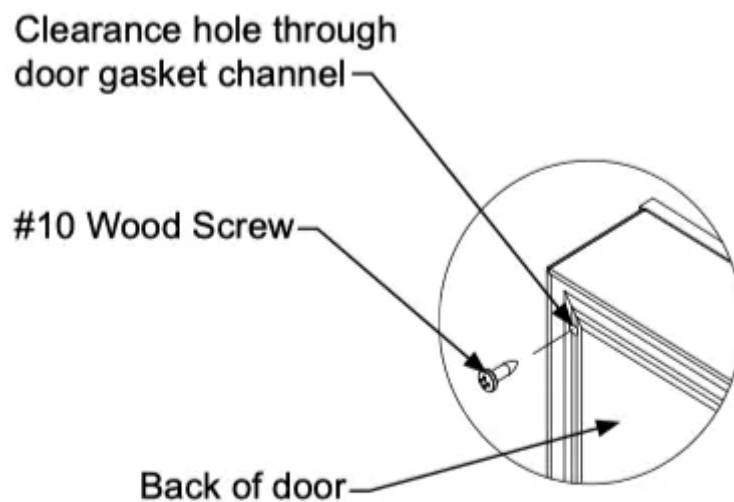

Figure 44

Step 8: Install door gasket

Press the door gasket into the door channel. Make certain the gasket corners are fully inserted. If applicable insert the key into the lock and make certain the lock operates properly.

Step 9: Install the door

Install the top and bottom hinge adapter bushings back into the hinge adapters that were removed in step 6. Install the door by reversing the procedure from step 2. Install the top hinge pin so the screw head is flush with the top surface of the hinge. A hinge parts reference diagram is shown in Figure 45.



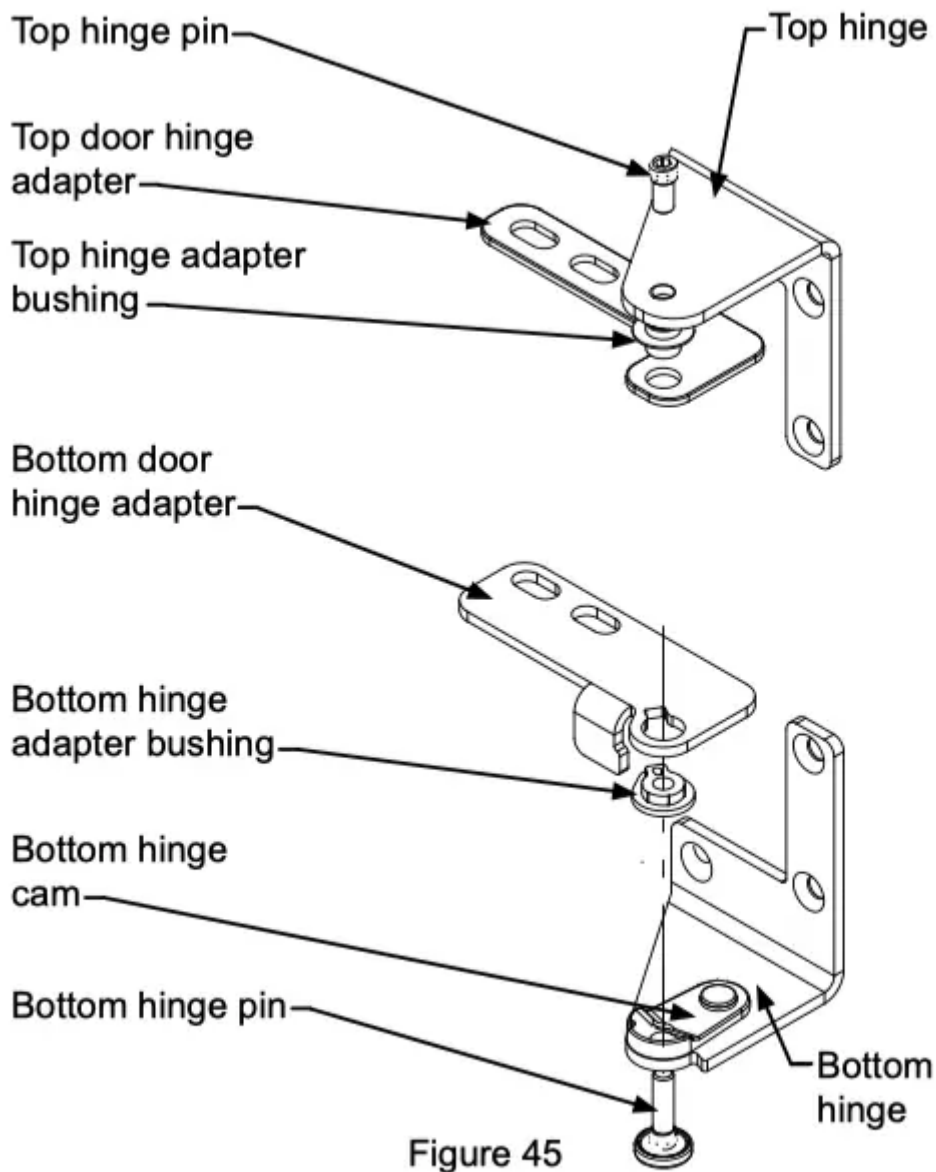

Figure 45
Right hand
hinges shown

TROUBLESHOOTING THE ICE MACHINE

Before You Call for Service

If the appliance appears to be malfunctioning, read through this manual first. If the problem persists, check the troubleshooting guide below. Locate the problem in the guide and refer to the cause and its remedy before calling for service. The problem may be something very simple that can be solved without a service call. However, it may be required to contact your dealer or a qualified service technician.

Troubleshooting guide:

Ice Machine Operation

Ice machine does not operate

- Is the ice machine's power cord plugged in? Plug the power cord into a grounded 3 prong outlet.
- Is the electronic control showing the "ICE" position? Check the control to be sure it is in the "ICE" position.
- Is a fuse blown or a circuit breaker been tripped? Replace a blown fuse or reset a tripped circuit breaker.
- Is the temperature of the room cooler than it normally is? The minimum room temperature is 55°F (13°C). The bin thermistor may be sensing the room temperature and shut off before the bin is full of ice. If the room temperature remains low the ice machine may not restart.
- Is there a drain pump in the ice machine? The drain pump is designed to temporarily shut the unit off when large quantities of water create a high-limit condition. Wait a few minutes as the drain pump will continue to operate to dispose of the excess water. If there is still water in the ice bin check the drain pump vent line and drain line for obstructions or kinking.

The ice machine is noisy

Many sounds of an ice machine are different than your household refrigerator. This subject is discussed on page 11, but check the following:

- Do you hear water being circulated in the ice machine? This is a normal sound as water is added once every ice making cycle.
- Is there a "whoosing" sound? Make sure water is getting to the ice machine. Also check to make sure the drain plug is fully seated in the water reservoir.
- Is there an ice slab caught between the evaporator plate and the grid cutter? First check to see if the ice machine is level. If the ice machine is level run a cleaning cycle.

WARNING

Electrocution Hazard

- Never attempt to repair or perform maintenance on the appliance until the main electrical power has been disconnected. Turning the appliance control "OFF" does not remove electrical power from the unit's wiring.
- Replace all parts and panels before operating.

Ice Production

Little or no ice production from the ice machine

- Is the electronic control set to the "ICE" position? Check the control to be sure it is in the "ICE" position.
- Is water getting to the ice machine? Make sure nothing is restricting the water supply such as a closed water valve or a blown fuse or tripped circuit breaker, or a kinked supply line, or low water pressure.
- Has the ice machine just been started? A typical ice production cycle can take up to 11/2 hours. Initial start up cycles can take longer. Check the ice machine after 24 hours for ice accumulation in the bin.
- Is the reservoir drain plug in place? Check that the reservoir drain plug is properly seated.
- Is the water distributor tube restricted? Run a cleaning cycle to clean the ice machine. Also check any filters to make sure they are not restricted.
- Is the condenser fan air flow restricted? Make sure the grille in the front of the ice machine is open for proper air circulation.
- Is the room and/or water temperature too warm? Move the ice machine to an area where the ambient temperature is below 90°F (32°C) for built-in ice machines or below 100°F (38°C) for freestanding ice machines. The ice machine should not be placed next to a heat source such as an oven. Check the cold water connection.
- Is there scale build up in the ice machine? If there is scale build up on the evaporator, the ice machine needs to be cleaned. See "Cleaning the Ice machine".

Ice Quality

Odor, grey color, or off taste in the ice

- Is there mineral scale build up on the evaporator plate? The ice machine needs cleaning. See "Cleaning the Ice Machine".
- Is there a high mineral content in the water? The water may need to be filtered.
- Are food items being stored in the ice bin? Remove food from the ice bin.
- Unpleasant Odors may require the use of a charcoal filter on the water supply line.

Clumps of ice

- Are there clumps of ice in the bin? If the ice isn't used on a regular basis it will melt and form into clumps. Break up the ice clumps with the ice scoop.

Ice cubes are too big or too small

- Is there low ice consumption? Ice is slowly melting in the ice bin which will affect the size of the cubes. This is normal. When the ice bin needs to be replenished, cubes will return to the regular size.

- Is the ice slab releasing? Clean the evaporator. See “Cleaning the Ice Machine”.
- Is the distributor tube restricted? Check the water line to the ice machine to make sure there are no restrictions or kinks in the line. Check all filters to make sure they are not restricted. Check that the water flows evenly out of the distributor tube, if not, clean the ice machine. See “Cleaning the Ice Machine”.

Plumbing Problems

- Is the drain hose aligned over the drain? Move the ice machine to align the drain.
- Is the ice machine draining properly? Check that there are no kinks or restrictions in the drain lines; this can cause water to back up in the ice bin. Check that foreign material is not blocking the ice bin drain located at the right rear corner of the ice bin. Check the drain pump discharge and vent line or any restrictions or kinks. Check that the drain pump is level.

NOTE

If there are plumbing issues outside of the ice machine, they cannot be repaired by the service technician. A qualified plumber will have to be called.

Troubleshooting the Drain Pump

NOTE

If the drain pump reservoir (not the ice machine bin) reaches overflow condition, the power to the ice machine will be shut off.

If the ice machine is not working, check the following:

- Make sure there is power at the receptacle.
- Make sure the ice machine is turned on.
- Make sure the ice bin is not full.

Then check the drain pump:

The pump does not run:

- Make sure the pump is plugged in and there is power to the receptacle.
- Check the inlet to the drain pump for debris and clean as needed. Remove clamps and inlet tube from drain pump to check for and remove debris.
- Make certain the vent line is free of kinks/sharp bends or restrictions.
- Make certain there is enough water to activate the drain pump. It will take at least one (1) quart (.95 liters) of water to activate the drain pump.

The pump runs, but no water is pumped out:

- Check that the vent is clear and free of restrictions.

- Check the discharge line to make certain there are no restrictions.
- Make sure that the discharge tubing has not exceeded the maximum lift of eight (8) feet (2.44 meters) and the horizontal run is not greater than twenty (20) feet (6.1 meters).

The pump runs and then quickly turns off repeatedly:

- Check to make certain the drain pump is level.
- Check that the vent is clear and free of restrictions.

The ice machine is running but not producing ice:

- Check to make sure water is not backing up in the ice bin.

PREPARING THE ICE MACHINE FOR STORAGE

If the ice machine is moved, not used for an extended period of time, or will be in an area that will be near freezing temperatures, it is necessary to remove any remaining water in the ice-making system.

CAUTION

This ice machine must have all water drained and removed to prevent ice machine damage as well as possible water damage to the surrounding area in freezing conditions. These damages are not covered under warranty.

CAUTION

Do not use any type of anti-freeze or other solution as a substitution for properly draining the ice machine.

Clean the Ice Machine

Cleaning the ice machine will help prevent mold and mildew growth as well as sanitize the ice machine for storage or when it is put back into service. See page 17 for instructions for cleaning the ice machine.

WARNING

Electrocution Hazard

Risk of electrical shock or personal injury could occur due to moving components, if machine compartment access cover is removed before unplugging the ice machine.

Draining and Removing Water from the IceMaking System with a Gravity Drain.

1. Turn off the water supply to the ice machine.
2. Disconnect the water supply fitting at the inlet of the water valve. (See Figure 46a).

3. Change the electronic control to the "CLEAN" position for approximately one (1) minute. This will energize and open the water valve and remove most of the water from the water valve and the water valve's outlet water line to the reservoir.

4. Change the electronic control to the "OFF" position.

This will energize and open the drain valve to drain the reservoir and the ice machine drain system.

5. Unplug the ice machine from the electrical outlet.

6. Remove the access cover from the rear of the ice machine. (See Figure 47).

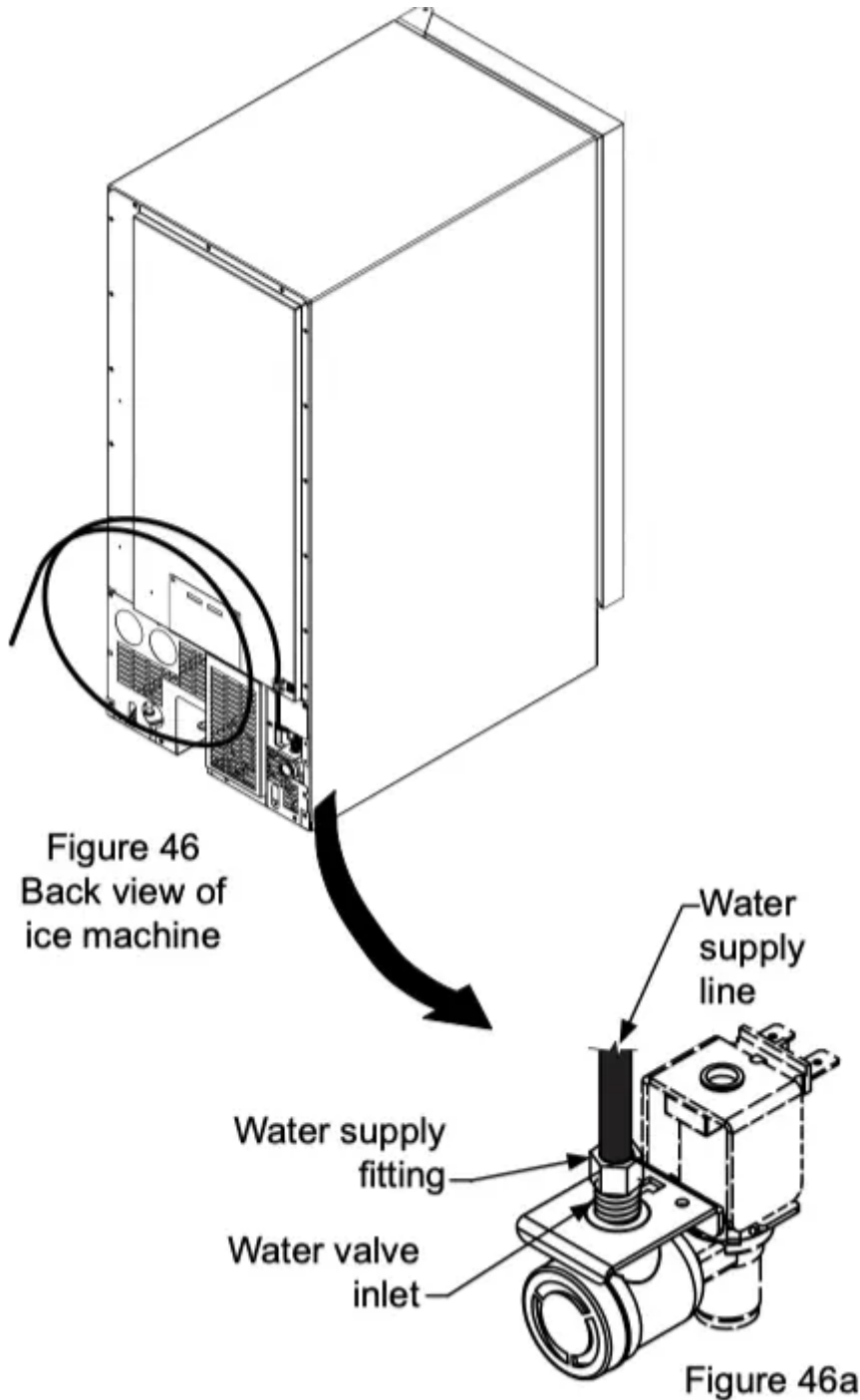

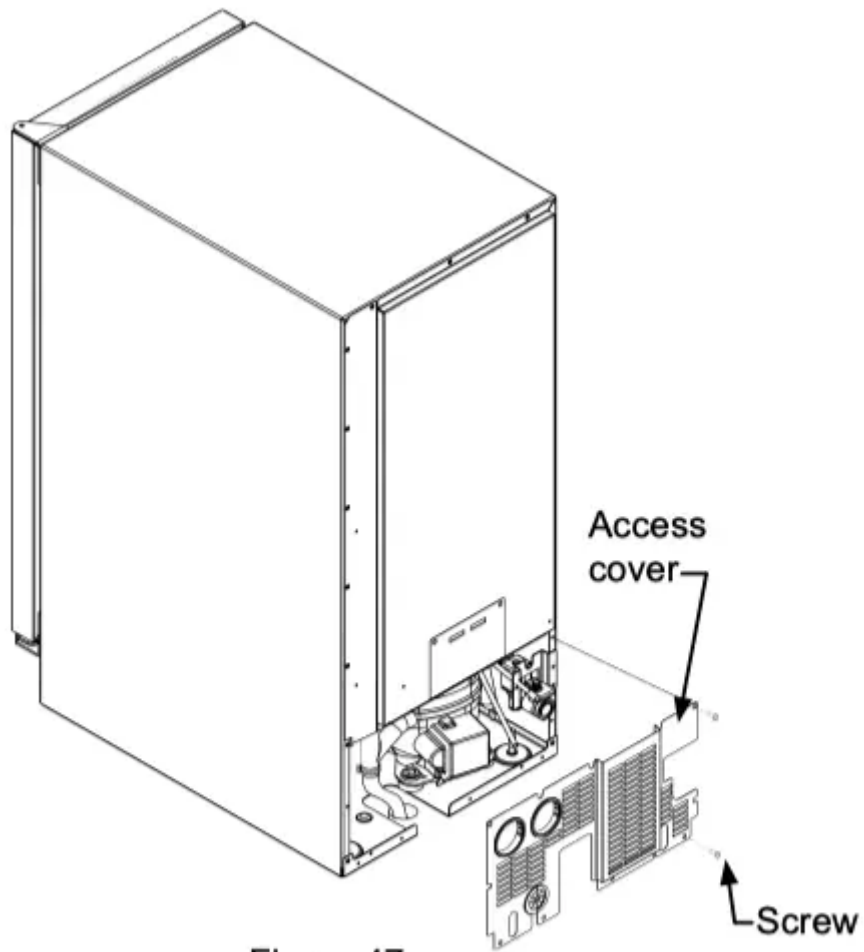

Figure 47

7. Disconnect the water valve's outlet water line to the reservoir and drain the remaining water left in the water line trap area. (See Figure 48 and 48a).



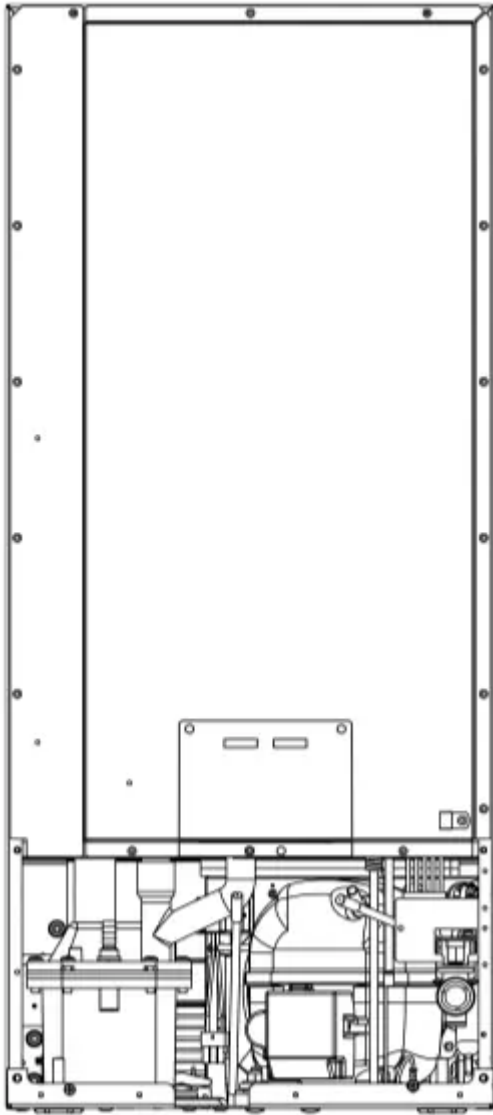

Figure 48

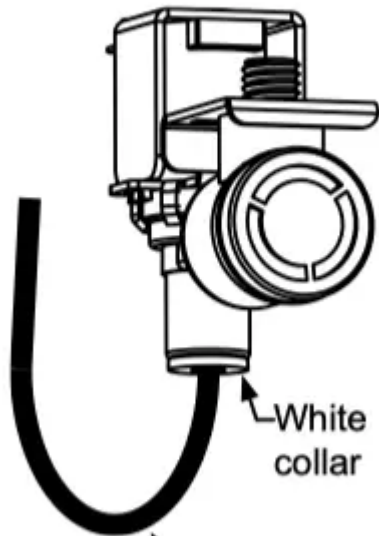

Figure 48a

White collar

Plastic outlet water line



To disconnect the water outlet line: Push up on the white collar and pull the plastic water line from the bottom of the water valve.

To reconnect the water outlet line: Simply insert the plastic tubing into the white collar and push until it stops (about 1/2", 12 mm, of water line will enter the valve).

8. Reconnect the water valve outlet water line.

(See Figure 48 and 48a).

9. Reinstall the ice machine's access cover.

10. Clean and dry the ice machine's storage bin.

11. Prop the door open for air circulation to prevent mold and mildew.

12. Leave the water supply line disconnected or reconnect the supply line and leave it shut off. Do NOT turn the water on and allow water to enter back into the water valve.

Draining Water for Factory Installed Drain Pump Applications

Follow steps 1 through 12 for the gravity drain then do the following:

13. Install the winterization plug in the water drain hole inside the ice bin. (See Figure 34).

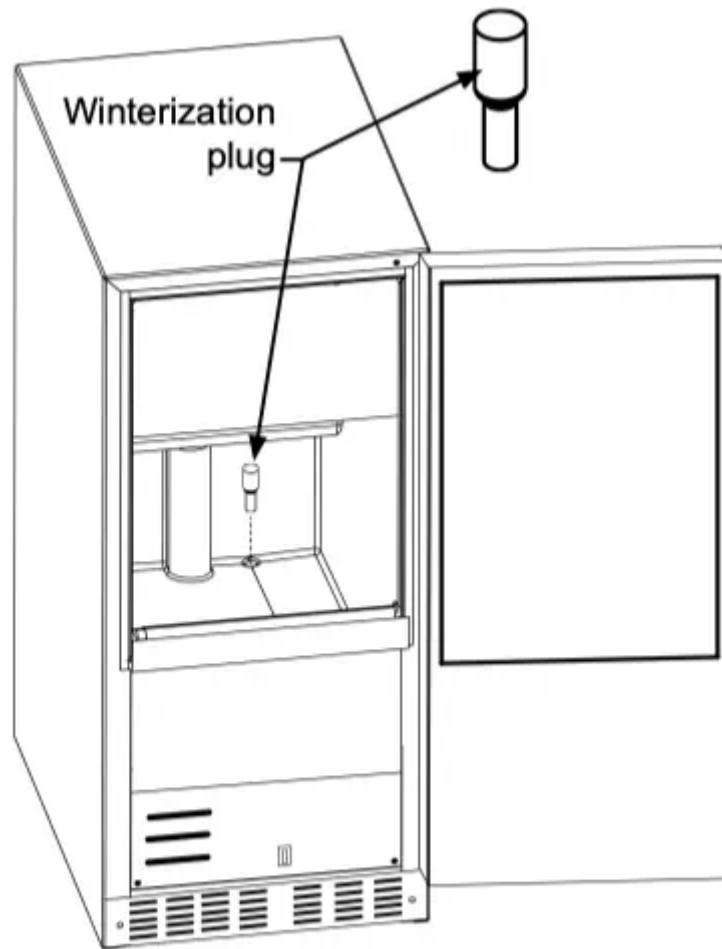
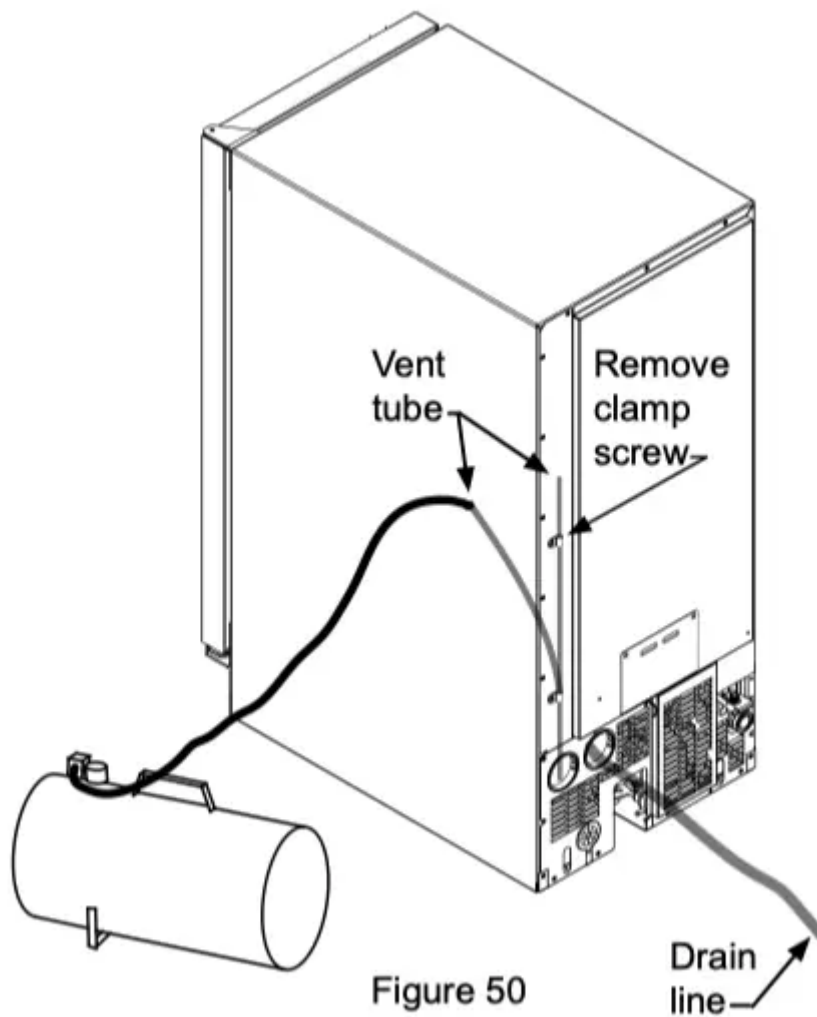

Figure 49

14. Remove the top clamp from the vent tube, for easier access for the air hose.
15. Apply air pressure (approximately 10 psi) to the end of the vent tube which will purge the remainder of the water from the drain pump and the drain line. (See Figure 50).
16. Reinstall the vent tube and clamp to the back of the ice machine and remove the winterization plug from the ice bin and save it for future use.



To Restart the Ice Machine

1. Reconnect or turn on the water supply line.
2. Reconnect drain tubing if removed.
3. Plug in the power cord to a wall outlet and turn the ice machine on, (refer to page 16 for turning the ice machine on and off).
4. Check the water inlet, drain lines, and fittings for any water leaks.
5. Check drain pump (if equipped) operation by pouring approximately two (2) quarts of water into the ice storage bin. The drain pump should activate and discharge water (refer to Drain Pump on page 7). Check for water leaks at all hose connections.

Drain Pump Removal Instructions:

1. Unplug the ice machine from the electrical supply and remove the rear access cover from the ice machine. (See page 33 for instructions).



2. Remove the front panel and the toe grille from the front of the ice machine. See Figures 52 and 52a.
3. Remove the front and rear drain pump brackets. See Figures 53, 53a and 54.
4. Unscrew the 3 hose clamps and remove the 3 hoses from the front of the drain pump. (See Figure 51).
5. Unscrew the leveling leg in the back corner until the end of the threaded portion is flush with the threaded nut insert in the base. (see Figure 51).

Remove these 3 hose clamps, then remove the 3 tubes from the drain pump

Unscrew the leveling leg so the end of the threads is flush with the top of the nut insert.

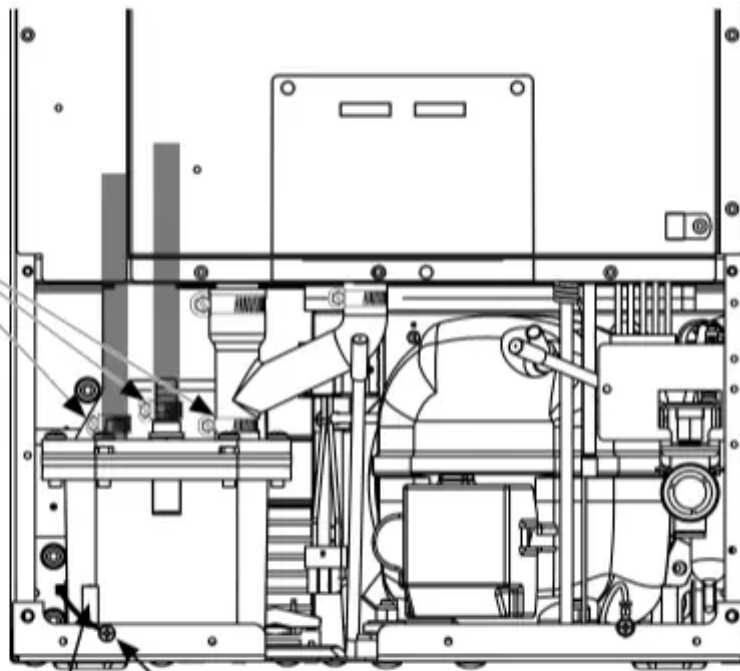
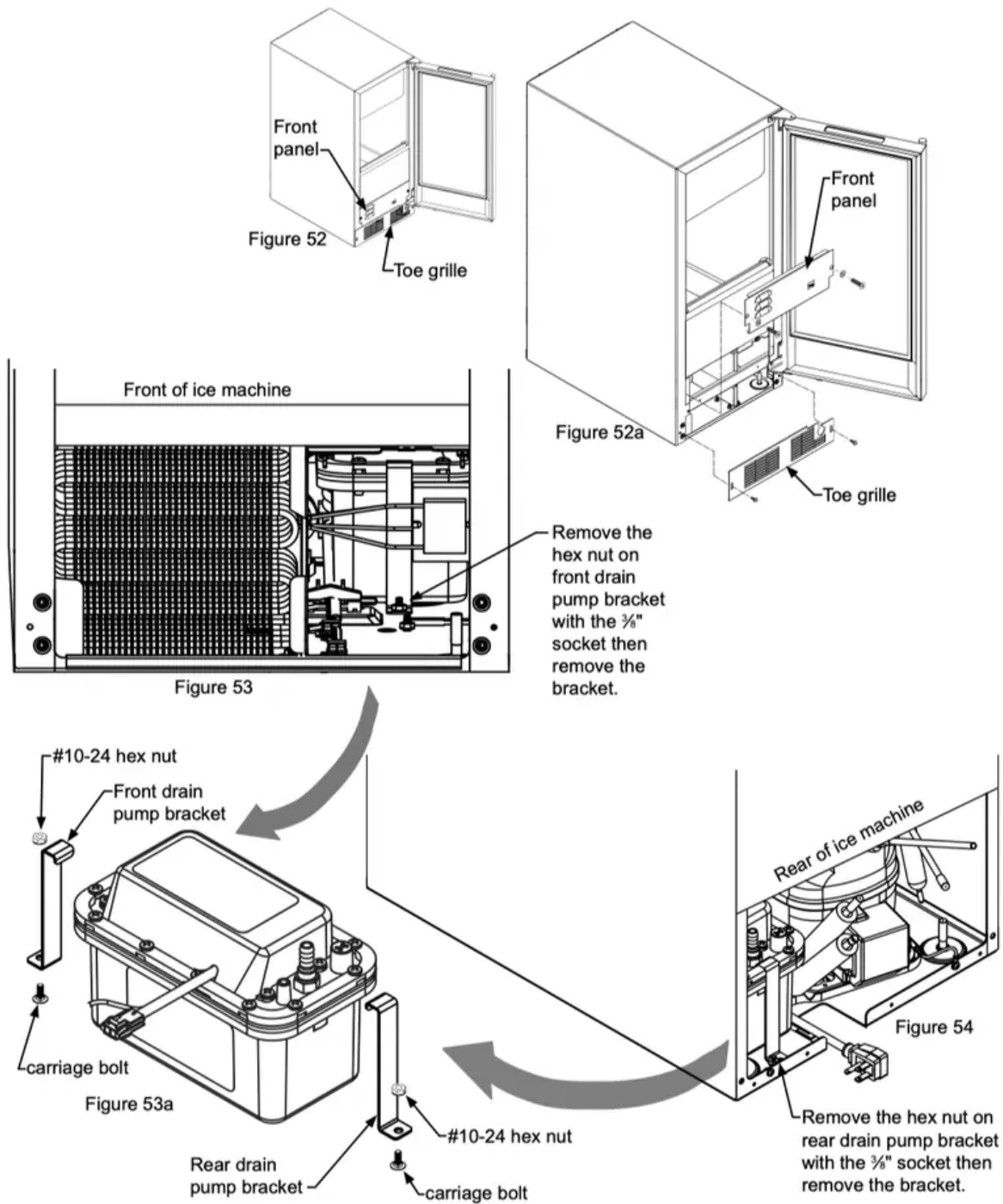

Figure 51

Drain pump ground wire connection

DRAIN PUMP REMOVAL INSTRUCTIONS



6. Rotate the drain pump and remove from the ice machine, (See Figure 55). It may be necessary to disconnect the ground wire connection in the back flange of the cabinet. (See Figure 51).

7. Disconnect the ice machine power cord from the drain pump (See Figure 56).

8. Drain the water in the drain pump's reservoir by turning the pump upside down and allowing water to drain through the pump's inlet and vent tube fittings.

9. Installation of drain pump is reverse of this procedure.

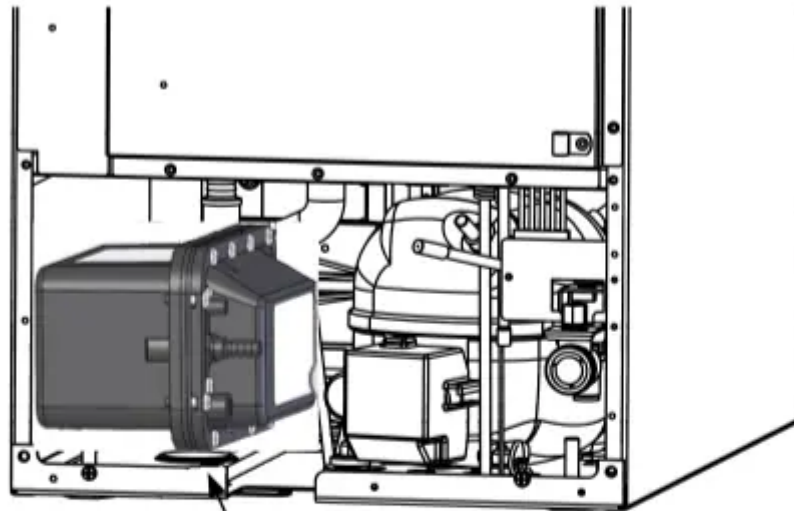

Figure 55

Rotate drain pump and remove from back of ice machine.

Additional issues to be inspected by the installer upon service replacement:

1. The drain pump must be level.
2. No pinched water lines.
3. No interference with electrical cords or wiring.
4. The drain pump should not set on any obstacles, wiring, etc.
5. Secure all hose clamps leading to and from the drain pump.
6. Insure that the vent tube height is adequate 18 inches minimum.
7. Insure that drain height is adequate maximum of 8 feet.
8. Insure that drain length is adequate maximum of 20 feet.
9. Checked for water leaks after installation of the drain pump.
10. Check for vibrations caused by improper installation.
11. Insure that there is no interference with back access cover.
12. Insure that the hole grommets are in place at each location so that any vent or drain tubes do not rub on any sharp surfaces.

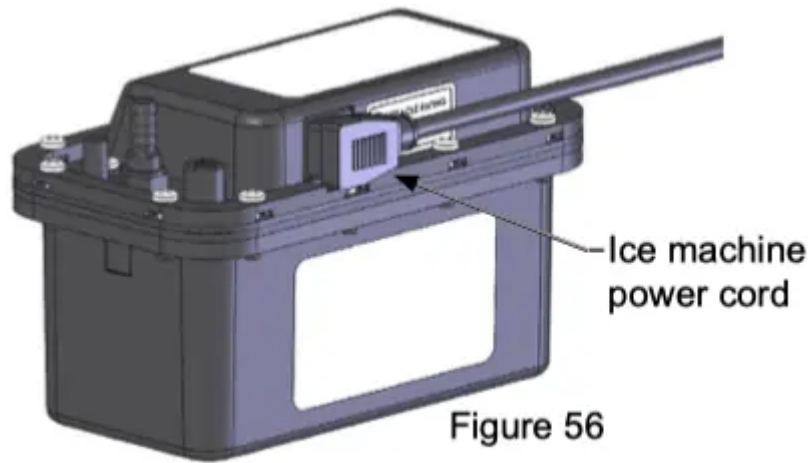

Figure 56

Warning

This content is compiled from multiple sources and is provided for reference purposes only. It may not be complete or fully applicable to all situations. If you are unable to resolve your issue, please contact the product manufacturer or an authorized service provider for official support.