

Operating Instructions Cordless Telephone

Setting up

Connections

1. Connect the AC adaptor to the unit by pressing the plug firmly.
2. Fasten the cord by hooking it.
3. Connect the AC adaptor to the power outlet.
4. Connect the telephone line cord to the unit, then to the single-line telephone jack (RJ11C) until you hear a click.
5. A DSL/ADSL filter (not supplied) is required if you have a DSL/ADSL service

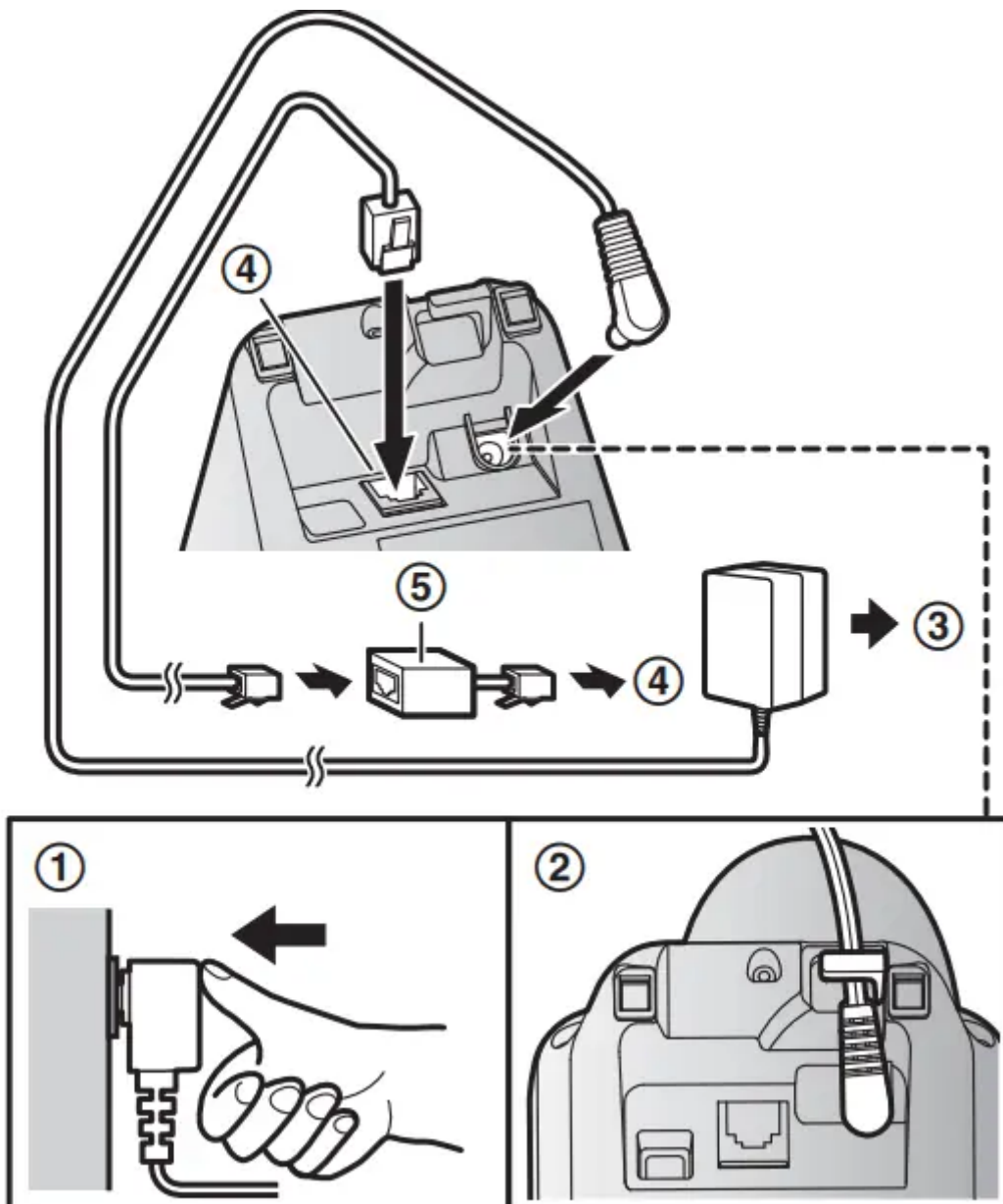





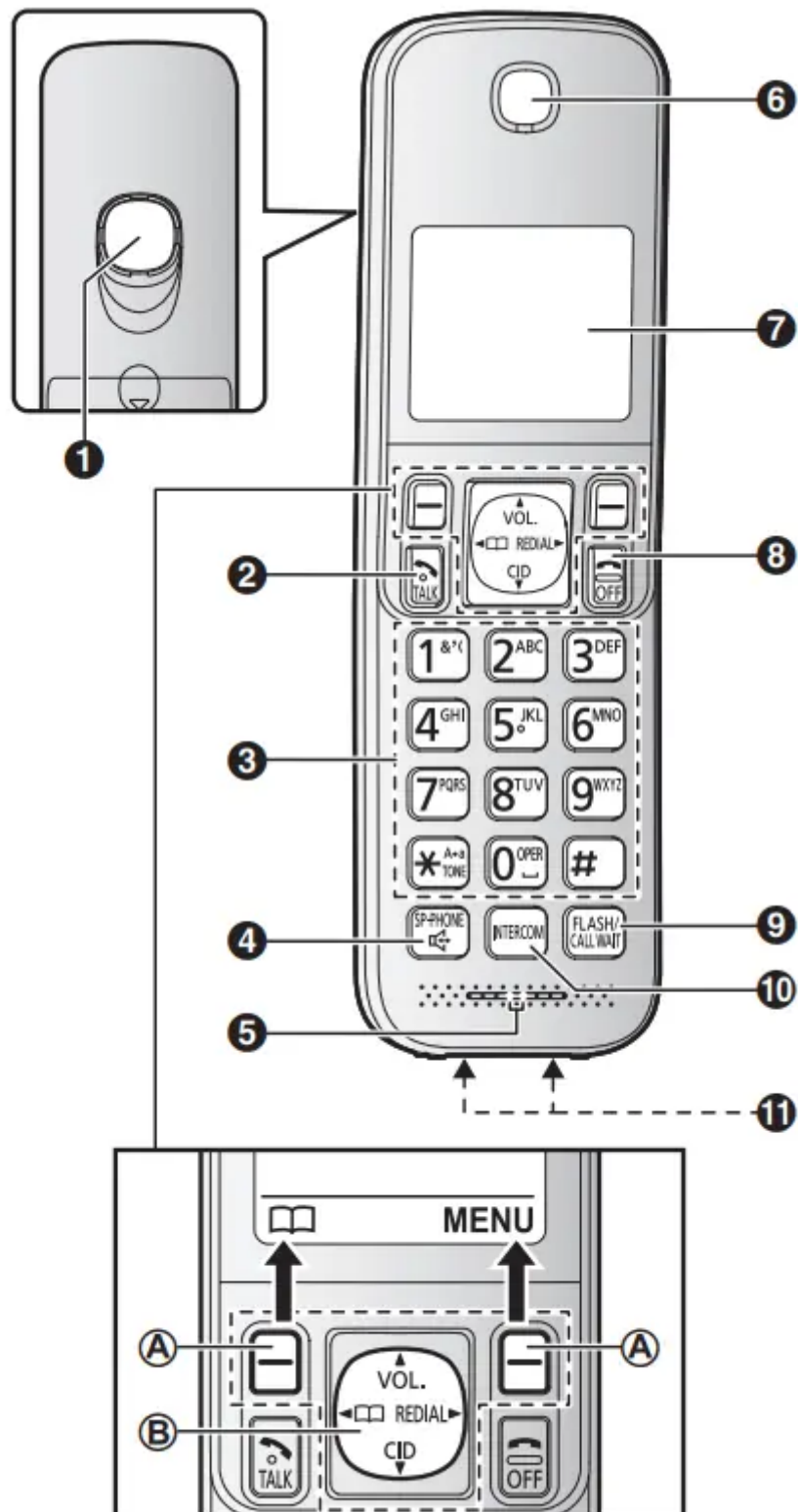







Controls

Handset



1 Speaker

- ② **[] (TALK)**
- ③ **Dial keypad (): TONE)**
- ④ **[] (SP-PHONE: Speakerphone)**
- ⑤ **Microphone**
- ⑥ **Receiver**
- ⑦ **Display**
- ⑧ **[OFF]**
- ⑨ **[FLASH][CALL WAIT]**
- ⑩ **[INTERCOM]**
 - This feature is available between 2 handsets.
- ⑪ **Charge contacts**
 - Ⓐ **Soft keys**
 - Ⓑ **Navigator key**
 - [, [, [, or []: Scroll through various lists and items.
 - VOL. (Volume: [] or []): Adjust the receiver or speaker volume while talking.
 - [] : View the phonebook entry.
 - [] REDIAL: View the redial list.
 - [] CID (Caller ID): View the caller list.

Base unit

KX-TGC350 series





- 1** Charge contacts
- 2** [•)] (LOCATOR)

KX-TGC360 series



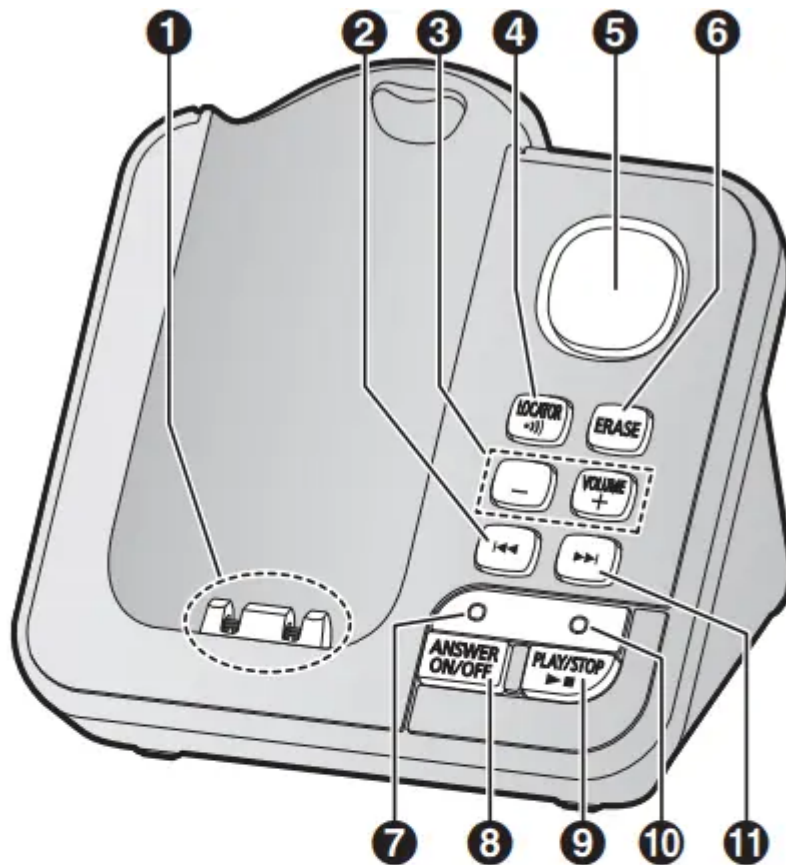













- 1** Charge contacts
- 2** [⏮] (Repeat)
- 3** [⏮]/[⏭] (VOLUME: Volume up/down)
- 4** [📶] (LOCATOR)
- 5** Speaker
- 6** [ERASE]
- 7** ANSWER ON/OFF indicator
- 8** [ANSWER ON/OFF]
- 9** [▶■] (PLAY/STOP)
- 10** Message indicator
- 11** [▶▶] (Skip)

Display icons

Handset display items

Item	Meaning
	Within base unit range
	Out of base unit range
	<p>The line is in use.</p> <ul style="list-style-type: none"> ● When flashing: The call is put on hold. ● When flashing rapidly: An incoming call is now being received.
	Eco mode is on. (page 9)
	Speakerphone is on. (page 12)

Item	Meaning
	Ringer volume is off. (page 12)
	Silent mode is on. (page 20)
	Call sharing mode is off. (page 19)
	Alarm is on. (page 20)
	Handset number
	Battery level
	Blocked call (page 20)
	Clarity booster is on automatically.
In use	Answering system is being used by the base unit (KX-TGC360 series) or another handset.
Line in use	Someone is using the line.

Language settings

Display language





1. **[MENU] # 1 1 0**
2. : Select the desired setting. → **[SAVE]** → **[OFF]**

Voice guidance language (KX-TGC360 series)

1. **[MENU] # 1 1 2**

2. : Select the desired setting. → **[SAVE]** → **[OFF]**

Date and time

1. **[MENU]**  **1** **0** **1**
2. Enter the current month, date, and year by selecting 2 digits for each. Example: July 15, 2016   
3. **[OK]**
4. Enter the current hour and minute (12-hour clock format) by selecting 2 digits for each. Example: 9:30 **09** **30**
5. *: Select "AM" or "PM".
6. **[SAVE]** → **[OFF]**



Recording your greeting message (KX-TGC360 series)

You can record your own greeting message instead of using a pre-recorded greeting message. See page 24 for details.

1. **[MENU]**  **3** **0** **2**
2. : "Yes" → **[SELECTN]**
3. Record a greeting message. → **[STOP]** → **[OFF]**



Other settings

Dialing mode

1. **[MENU]**  **1** **2** **0**
2. : Select the desired setting. → **[SAVE]** → **[OFF]**

Making/Answering Calls

Making calls

1. Lift the handset and dial the phone number.
° To correct a digit, press **[CLEAR]**.
2.  or . To adjust the receiver or speaker volume, press **[▲]** or **[▼]** repeatedly. 3 When you finish talking, press **[OFF]**

Making a call using the redial list

The last 5 phone numbers dialed are stored in the redial list.

1. **[▶]** REDIAL
2. **[↕]**: Select the desired entry. → **[↶]**

Pause (for PBX/long distance service users)

A pause is sometimes required when making calls using a PBX or long distance service. When storing a calling card access number and/or PIN in the phonebook, a pause is also needed (page 15).

Example: If you need to dial the line access number “9” when making outside calls with a PBX:

1. **[9]** → **[▲]** (Pause)
2. Dial the phone number. → **[↶]**

Answering calls

1. Lift the handset and press **[↶]** or **[↵]** when the unit rings.
2. When you finish talking, press **[OFF]**

Auto talk: You can answer calls simply by lifting the handset (page 19).

Temporary handset ringer off: Press **[🔕]**.

Useful features during a call

Hold

1. Press **[MENU]** during an outside call.
2. **[↕]**: “Hold” → **[SELECT]**
3. To release hold, press **[↶]**

Mute

1. Press **[MUTE]** during a call.
2. To return to the call, press **[MUTE]**.

Flash

- **[FLASH]** allows you to use the special features of your host PBX.

Phonebook

You can add 50 names (16 characters max.) and phone numbers (24 digits max.) to the phonebook.

Adding phonebook entries

1. or → **[MUTE]**
2. : "Add new entry" → **[SELECT]**
3. Enter the party's name. → **[OK]**
4. Enter the party's phone number. → **[OK]**
5. : Select the desired group **[SELECT]** 2 times → **[OFF]**

Entering characters

- Press the dial key that corresponds to the desired character. Press repeatedly to scroll through the available characters.
- The following operations are also available

Key	Operation
	Switch between the uppercase and lowercase (A ↔ a)
	Move the cursor
[CLEAR]	Erase the character or number <ul style="list-style-type: none">• To erase all, press and hold it.

Storing a redial list number to the phonebook









1. REDIAL
2. : Select the desired entry. → **[SAVE]**
3. To store the name, continue from step 3, "Editing entries", page 15.

Groups





You can assign your phone entries to groups for each searching. You can assign a ringtone to each group to help identify incoming calls (Caller ID required).



Changing group names/setting ringer ID

1.  or   → **[MENU]**
2. : “Group” → **[SELECT]**
3.  : Select the desired group → **[SELECT]**
4. To change group names
 - : “Group name” → **[SELECT]** → Edit the name → **[SAVE]**
 - : Select the current setting of the group ringer tone. → **[SELECT]** → :
Select the desired ringer tone. → **[SAVE]**
5. **[OFF]**

Finding and calling from a phonebook entry

1.  or  
2. : Select the desired entry.
3. 

Useful Information

Voicemail service

- In addition to your unit’s answering system you may also have voicemail service from your phone service provider. Voicemail is an answering service that may be offered by your phone service provider. This service can also record calls when you are unavailable to answer the phone or when your line is busy. Messages are recorded on the phone company system and not on the unit’s answering system.
 - To use the voicemail service rather than the unit’s answering system, turn off the answering system (page 24).
- If you have unit’s answering system set to on and also the voicemail enabled, the system with least amount of rings will record the message first.
- Example: If the unit’s answering system is set to 4 rings (page 26) and the voicemail answering system provided by your phone company is set to 6 rings (call your service provider), the unit’s answering system will record the incoming call first.

Storing the voicemail (VM) access number

You can store the phone number used to access your voicemail service.

1. **[MENU]#331**
2. Enter your access number. → **[SAVE]** → **[OFF]**

Note: When storing your voicemail access number and your mailbox password, press **[v]** (Pause) to add pauses (page 12) between the access number and the password as necessary. Contact your phone service provider for the required pause time.

Example:

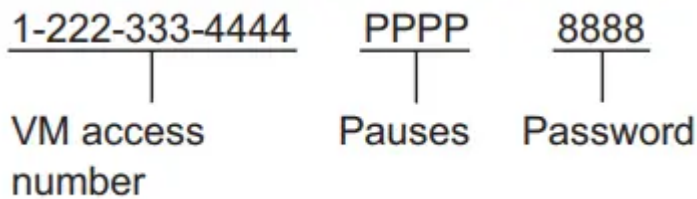

To erase the voicemail access number

1. **[MENU]#331**
2. Press and hold **[CLEAR]** until all digits are erased. → **[SAVE]** → **[OFF]**

Voicemail (VM) tone detection

Your voicemail service provider sends special signals to the unit to let you know that you have new voicemail messages. If you hear a series of dial tones followed by a continuous dial tone after you press **[hook]**, you have new voicemail messages.

The unit can detect these signals automatically. Turn this feature off in the following situations.

- You do not subscribe to voicemail service.
- Your phone is connected to a PBX.

Turning VM tone detection on/off

1. **[MENU]#332**
2. **[up/down]**: Select the desired entry. → **[SAVE]** → **[OFF]**

Listening to voicemail messages

1. **[MENU]#330**
 - The speakerphone turns on
2. Follow the pre-recorded instructions.
3. When finished, press **[OFF]**

Note:

- You can also use the [VM] soft key, if displayed, to play new voicemail messages.
- If the handset still indicate there are new messages even after you have listened to all new messages, turn it off by pressing and holding # until the handset beeps.

Error messages

Display message	Cause/solution
<p>Base no power or No link. Re-connect base AC adaptor.</p>	<ul style="list-style-type: none"> • The handset has lost communication with the base unit. Move closer to the base unit and try again. • Unplug the base unit's AC adaptor to reset the unit. Reconnect the adaptor and try again. • The handset's registration may have been canceled. Re-register the handset (page 22).
<p>Busy</p>	<ul style="list-style-type: none"> • Other units are in use and the system is busy. Try again later.
<p>Call phone company for your access #</p>	<ul style="list-style-type: none"> • You have not stored the voicemail access number. Store the number (page 28).
<p>Check tel line</p>	<ul style="list-style-type: none"> • The supplied telephone line cord has not been connected yet or not connected properly. Check the connections (page 8).
<p>Error!!</p>	<ul style="list-style-type: none"> • Recording was too short. Try again.
<p>Invalid</p>	<ul style="list-style-type: none"> • There is no handset registered to the base unit matching the handset number you entered.

	<ul style="list-style-type: none"> • The handset is not registered to the base unit. <p>Register the handset (page 22).</p>
Use rechargeable battery.	<ul style="list-style-type: none"> • A wrong type of battery such as alkaline or manganese was inserted. Use only the rechargeable Ni-MH batteries noted on page 4, 6.

Troubleshooting

If you still have difficulties after following the instructions in this section, disconnect the base unit's AC adaptor, then reconnect the base unit's AC adaptor. Remove the batteries from the handset, and then insert the batteries into the handset again.



General use

Problem	Cause/solution
The handset does not turn on even after installing charged batteries.	<ul style="list-style-type: none"> • Place the handset on the base unit or charger to turn on the handset.
The unit does not work.	<ul style="list-style-type: none"> • Make sure the batteries are installed correctly (page 8). • Fully charge the batteries (page 8). • Check the connections (page 8). • Unplug the base unit's AC adaptor to reset the unit. Reconnect the adaptor and try again. • The handset has not been registered to the base unit. Register the handset (page 22).

Useful Information

Problem	Cause/solution
I cannot hear a dial tone.	<ul style="list-style-type: none"> The base unit's AC adaptor or telephone line cord is not connected. Check the connections.
Time on the unit has shifted.	<ul style="list-style-type: none"> Incorrect time information from incoming Caller ID changes the time. Set the time adjustment to "Manual" (off) (page 18).

Battery recharge

Problem	Cause/solution
<p>I fully charged the batteries, but</p> <ul style="list-style-type: none">  still flashes,  is displayed, or the operating time seems to be shorter. 	<ul style="list-style-type: none"> Clean the battery ends ( , ) and the charge contacts with a dry cloth and charge again. It is time to replace the batteries (page 8).

Making/answering calls, intercom

Problem	Cause/solution
 is displayed.	<ul style="list-style-type: none"> • The handset is too far from the base unit. Move closer. • The base unit's AC adaptor is not properly connected. Reconnect AC adaptor to the base unit. • The handset is not registered to the base unit. Register it (page 22).
Noise is heard, sound cuts in and out.	<ul style="list-style-type: none"> • You are using the handset or base unit in an area with high electrical interference. Re-position the base unit and use the handset away from sources of interference. • Move closer to the base unit. • If you use a DSL/ADSL service, we recommend connecting a DSL/ADSL filter between the base unit and the telephone line jack. Contact your DSL/ADSL provider for details.
The handset does not ring.	<ul style="list-style-type: none"> • The ringer volume is turned off. Adjust the ringer volume (page 12, 18). • Silent mode is turned on. Turn it off (page 20).
I cannot make a call.	<ul style="list-style-type: none"> • The dialing mode may be set incorrectly. Change the setting (page 11).

Caller ID

Problem	Cause/solution
Caller information is not displayed.	<ul style="list-style-type: none">• You must subscribe to Caller ID service. Contact your phone service provider for details.• If your unit is connected to any additional telephone equipment such as a Caller ID box or cordless telephone line jack, plug the unit directly into the wall jack.• If you use a DSL/ADSL service, we recommend connecting a DSL/ADSL filter between the base unit and the telephone line jack. Contact your DSL/ADSL provider for details.• The name display service may not be available in some areas. Contact your phone service provider for details.
Caller information is displayed late.	<ul style="list-style-type: none">• Depending on your phone service provider, the unit may display the caller's information at the 2nd ring or later.

Answering system

Problem	Cause/solution
The unit does not record new messages.	<ul style="list-style-type: none">• The answering system is turned off. Turn it on (page 24).• The message memory is full. Erase unnecessary messages (page 24).• The recording time is set to "Greeting only". Change the setting (page 27).• Your phone service provider's voicemail service may be answering your calls before the unit's answering system can answer your calls. Change the unit's number of rings setting (page 26) to a lower value, or contact your phone service provider.

Voice mail

Problem	Cause/solution
<p>“New Voice Mail” is shown on the handset display. How do I remove this message from the display?</p>	<ul style="list-style-type: none"> • Listen your new voicemail messages (page 28). Depending on your voicemail service provider, you may need to erase all messages in your voice mailbox in order to remove this message. • You can remove this message manually by pressing and holding # until the unit beeps.

Liquid damage

Problem	Cause/solution
<p>Liquid or other form of moisture has entered the handset/base unit.</p>	<ul style="list-style-type: none"> • Disconnect the AC adaptor and telephone line cord from the base unit. Remove the batteries from the handset and leave to dry for at least 3 days. After the handset/base unit are completely dry, reconnect the AC adaptor and telephone line cord. Insert the batteries and charge fully before use. If the unit does not work properly, contact an authorized service center.

Caution: To avoid permanent damage, do not use a microwave oven to speed up the drying process

Wall mounting (Charger only)

Note: Make sure that the wall and the fixing method are strong enough to support the weight of the unit.

Drive the screws (A) (not supplied) into the wall. B 27.2 mm (1 1/16 inches)

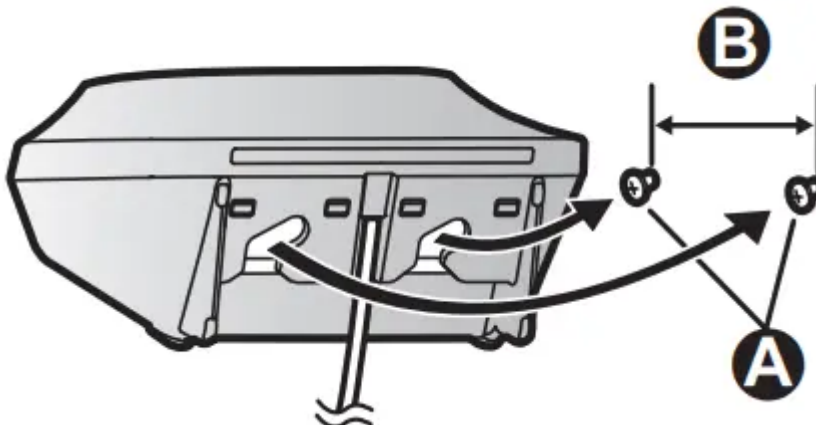

Warning

This content is compiled from multiple sources and is provided for reference purposes only. It may not be complete or fully applicable to all situations. If you are unable to resolve your issue, please contact the product manufacturer or an authorized service provider for official support.

Document generated by [ManualsFile](#)