

## REFRIGERATOR FEATURES

### Convertible Drawer Temperature Control (on some models)

The control can be adjusted to properly chill meats or vegetables. The air inside the pan is cooled to avoid “spot” freezing and can be set to keep meats at the National Livestock and Meat Board recommended storage temperatures of 28°to 32°F (–2°to 0°C).

#### To store meat:

Set the control to one of the three Meat settings to store meat at its optimal storage temperature.

#### To store vegetables:

Set the control to Veg to store vegetables at their optimal storage temperatures.

**NOTE:** If food starts to freeze, move the control to the right (less cold), toward the Veg setting. Remember to wait 24 hours between adjustments.

### Crisper Humidity Control (on some models)

You can control the amount of humidity in the moisture-sealed crisper. Adjust the control to any setting between Low and High.

**LOW** (open) for best storage of fruits and vegetables with skins.

**HIGH** (closed) for best storage of fresh, leafy vegetables.

### Dual Evaporator (on some models)

Some models come equipped with a dual sequential evaporation system which includes two separate evaporators for the refrigerator and freezer compartments.

Dual evaporation results in higher humidity, which helps keep foods in the refrigerator from spoiling as quickly and improves food quality and freshness in the freezer due to decreased freezer burn. In addition, the dual evaporation system helps keep food smells in the refrigerator from transferring to ice in the freezer.

**NOTE:** The dual evaporation system is always activated when your refrigerator is operating. You do not need to press any buttons to turn it on.

### Water and Ice Dispensers

On how to use your water and ice dispensers, see the online “Side-by-Side Refrigerator Dispensers” Feature Guide.

#### NOTES:

- Connect to potable water supply only.

- The dispensing system will not operate when either door (refrigerator or freezer) is open.
- Allow 24 hours for the refrigerator to cool down and chill water.
- Allow 24 hours to produce the first batch of ice. Discard the first three batches of ice produced. Wait 72 hours for full ice production.
- On some models, the display screen on the dispenser control panel will turn off automatically and enter “sleep” mode when the control buttons and dispenser pads have not been used for 2 minutes or more. While in “sleep” mode, the first press of a control button will only reactivate the display screen, without changing any settings.

### **Flush the Water System**

Air in the water dispensing system can cause the water dispenser to drip. After connecting the refrigerator to a water source or replacing the water filter, flush the water system. Flushing the water dispensing system forces air from the water line and filter and prepares the water filter for use.

**NOTE:** As air is cleared from the system, water may spurt out of the dispenser.

1. Using a sturdy container, depress and hold the water dispenser pad for 5 seconds; then release it for 5 seconds.
2. Repeat step 1 until water begins to flow.
3. Once water begins to flow, continue depressing and releasing the dispenser pad (5 seconds on, 5 seconds off) until a total of 3 gal. (12 L) has been dispensed.

Additional flushing may be required in some households.

### **The Water Dispenser**

**IMPORTANT:** Dispense at least 1 qt. (1 L) of water every week to maintain a fresh supply.

If the flow of water from the dispenser decreases, it could be caused by low water pressure.

- With the water filter removed, dispense 1 cup (237 mL) of water. If 1 cup of water is dispensed in 8 seconds or less, the water pressure to the refrigerator meets the minimum requirement.
- If it takes longer than 8 seconds to dispense 1 cup of water, the water pressure to the refrigerator is lower than recommended. See “Water Supply Requirements” or online “Troubleshooting” for suggestions.

### **Ice Maker and Storage Bin**

- Allow 24 hours to produce the first batch of ice. Discard the first three batches of ice produced.
- The quality of your ice will be only as good as the quality of the water supplied to your ice maker. Avoid connecting the ice maker to a softened water supply. Water softener chemicals (such as salt) can damage parts of the ice maker and lead to poor quality ice.

If a softened water supply cannot be avoided, make sure the water softener is operating properly and is well maintained.

- Do not use anything sharp to break up the ice in the storage bin. This can cause damage to the ice container and the dispenser mechanism.
- Do not store anything on top of or in the ice maker or storage bin.

### Style 1

#### Turning the Ice Maker On/Off:

The On/Off switch, located on the left wall of the freezer door, can only be accessed when the ice storage bin has been removed. See the following section for bin removal instructions.

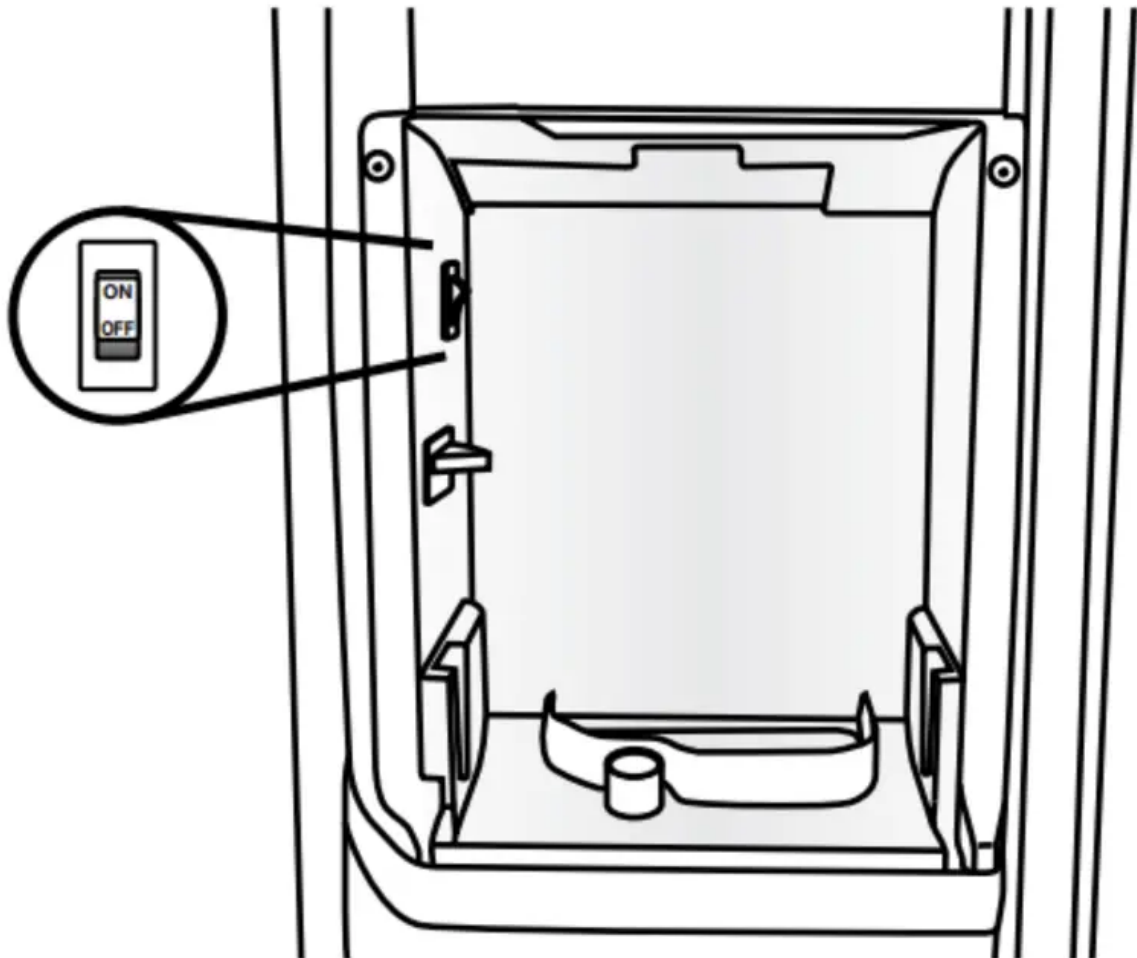

- To turn on the ice maker, flip the switch to the On (up) position.
- To manually turn off the ice maker, flip the switch to the Off (down) position.

**NOTE:** The ice maker has an automatic shutoff to keep the storage bin from overflowing during normal operation. As ice is made, the ice cubes will fill the ice storage bin, and the ice cubes will raise the shutoff arm to the Off (arm up) position. When the storage bin is at full capacity, the ice maker will automatically stop ice production, but the ice maker On/Off switch will remain in the On (up) position.

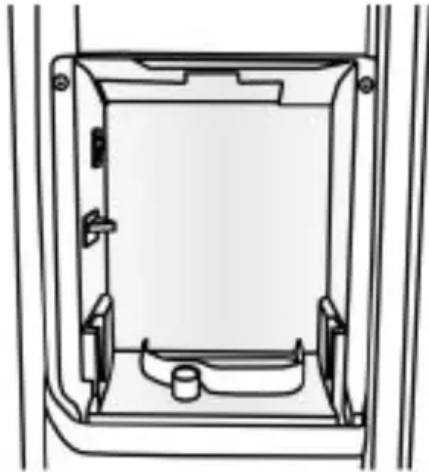

*Ice production Off (Shutoff arm up)*

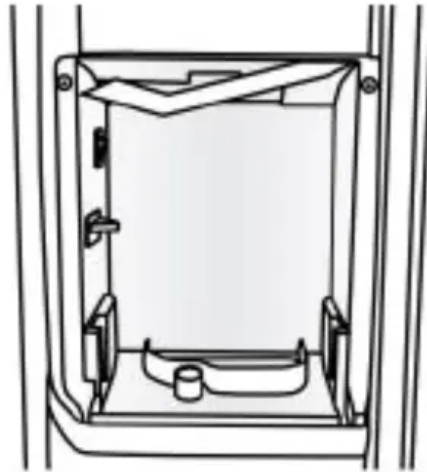

*Ice production On (Shutoff arm down)*

**Removing and Replacing the Ice Storage Bin:**

1. Press down the release lever and tilt the bucket outward. Use both hands to hold the base of the storage bin, and then lift it up and out.

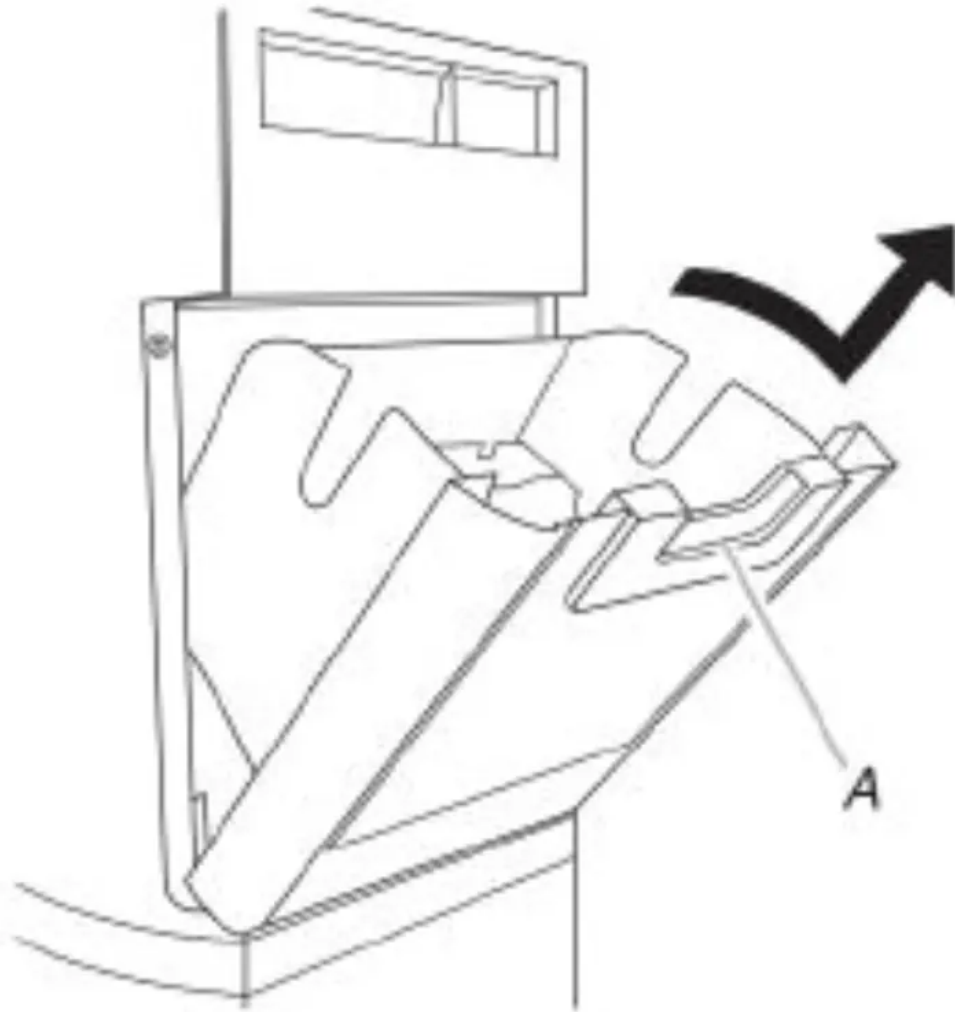

### ***A. Release lever***

**NOTE:** It is not necessary to flip the ice maker On/Off switch to the Off (down) position when removing the storage bin. The storage bin sensor, located on the left wall (right wall on some models) of the freezer door, stops the ice maker from producing ice if the



door is open or the storage bin is removed.

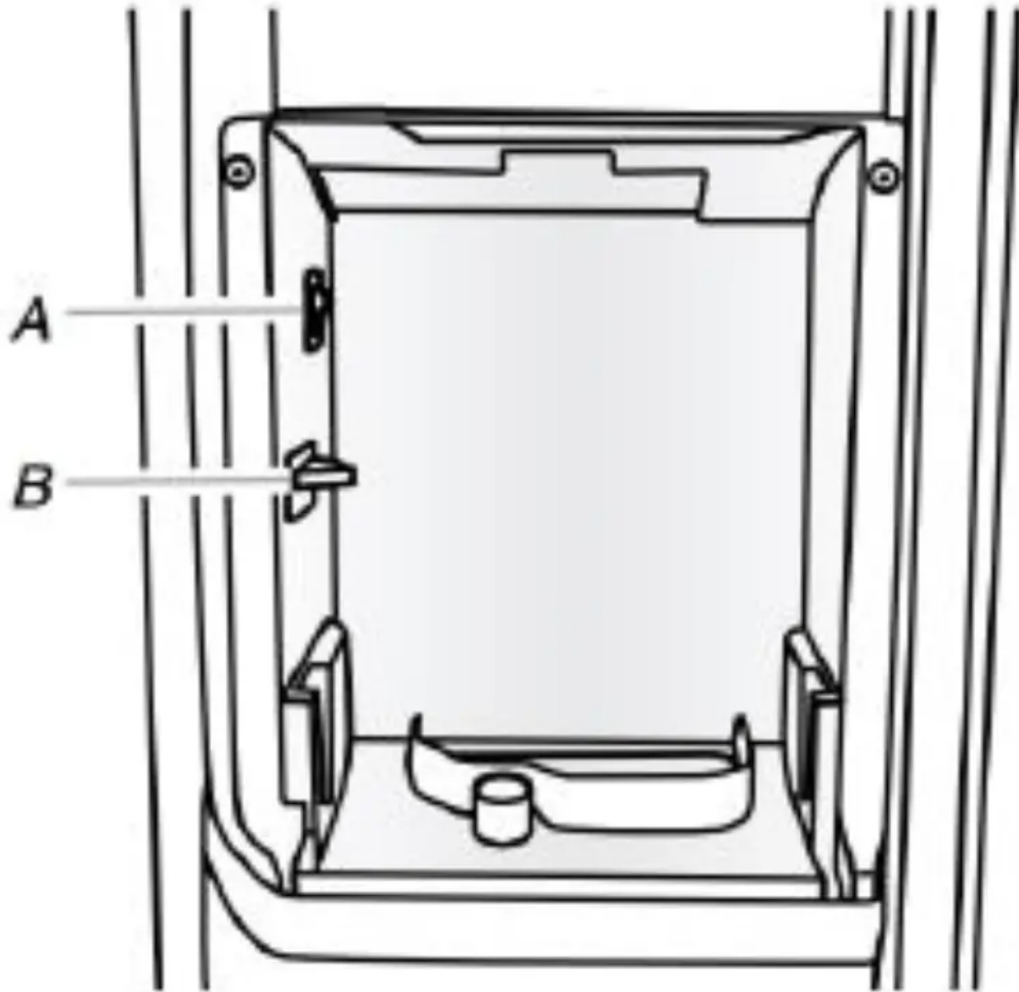

*A. On/Off switch      B. Storage bin sensor*

2. Replace the bin by sliding it onto the door, and then tilting it back into an upright position. The release lever will click when the bin is securely in place.

## **Style 2**

### **Turning the Ice Maker On/Off:**

- To turn on the ice maker, lower the wire shutoff arm to the On position.
- To manually turn off the ice maker, lift the wire shutoff arm to the Off (arm up) position and listen for the click. Ice can still be dispensed, but no more can be made.

**NOTE:** The ice maker has an automatic shutoff to keep the storage bin from overflowing during normal operation. As ice is made, the ice cubes will fill the ice storage bin, and the ice cubes will raise the wire shutoff arm to the Off (arm up) position. Do not force the wire shutoff arm up or down.

### Removing and Replacing the Ice Storage Bin:

1. Pull the covering panel up from the bottom.
2. Lift the wire shutoff arm so it clicks into the Off (up) position.
3. Lift up the front of the storage bin and pull it out.

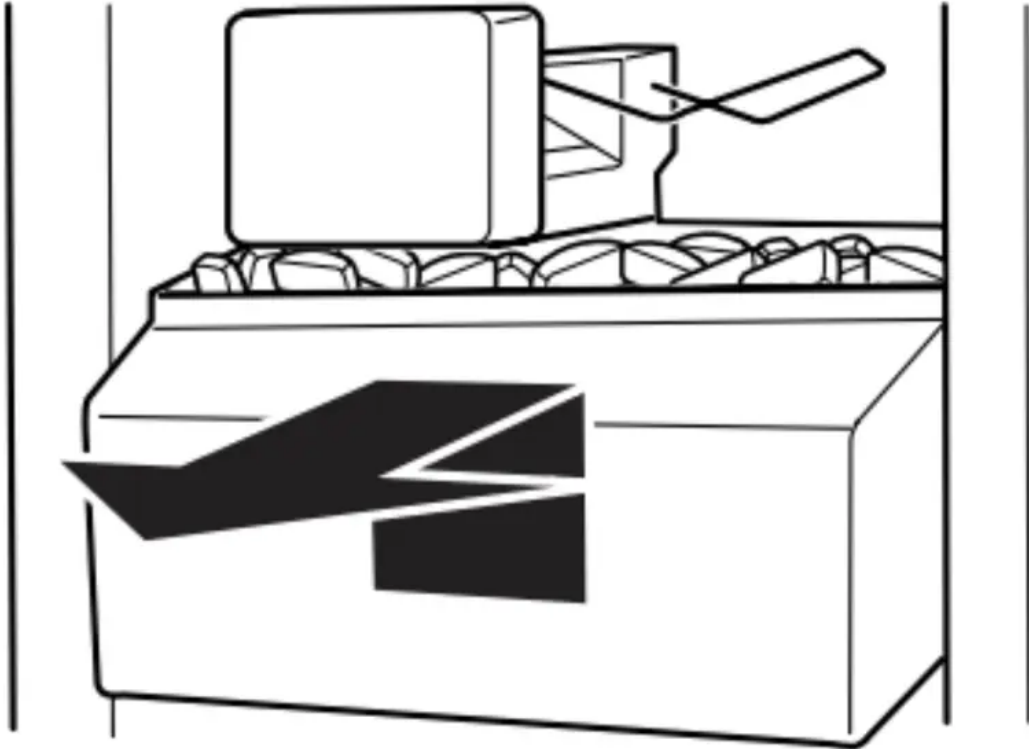

4. Replace the bin by pushing it in all the way or the dispenser will not work.
5. To restart ice production, lower the wire shutoff arm to the On (down) position. Make sure the door is closed tightly.

### Style 3

#### Turning the Ice Maker On/Off:

- To turn on the ice maker, lift open the ice maker door and lower the wire shutoff arm to the On position.
- To manually turn off the ice maker, lift the wire shutoff arm to the Off (arm up) position and listen for the click. Ice can still be dispensed, but no more can be made.

**NOTE:** The ice maker has an automatic shutoff to keep the storage bin from overflowing during normal operation. As ice is made, the ice cubes will fill the ice storage bin, and the ice cubes will raise the wire shutoff arm to the Off (arm up) position. Do not force the wire shutoff arm up or down.

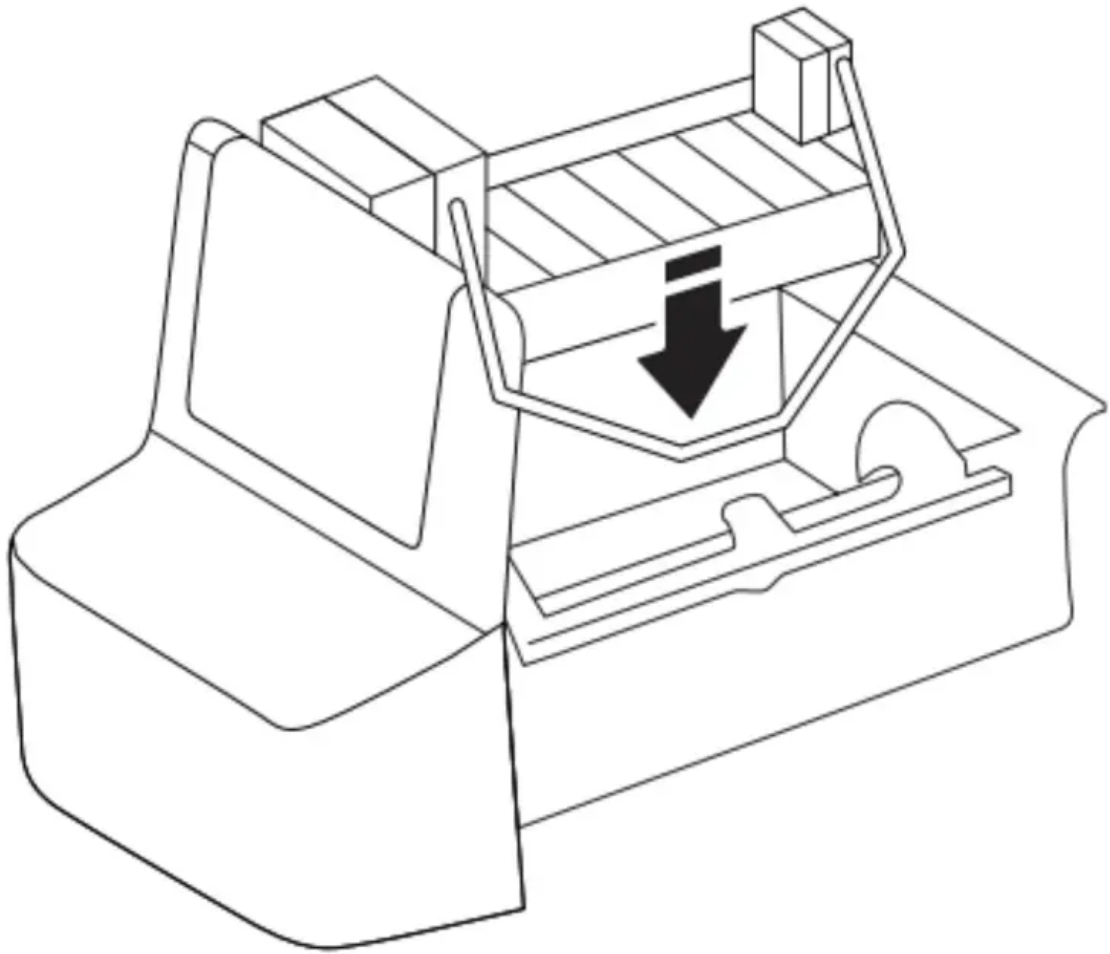

### **Removing and Replacing the Ice Storage Bin:**

1. Lift and hold open the ice maker door.
2. Lift the wire shutoff arm so it clicks into the Off (up) position.  
Release the ice maker door.
3. Lift up the front of the storage bin and pull it out.
4. Replace the bin by pushing it in all the way or the dispenser will not work.
5. To restart ice production, lift open the ice maker door and push the wire shutoff arm down to the On position.

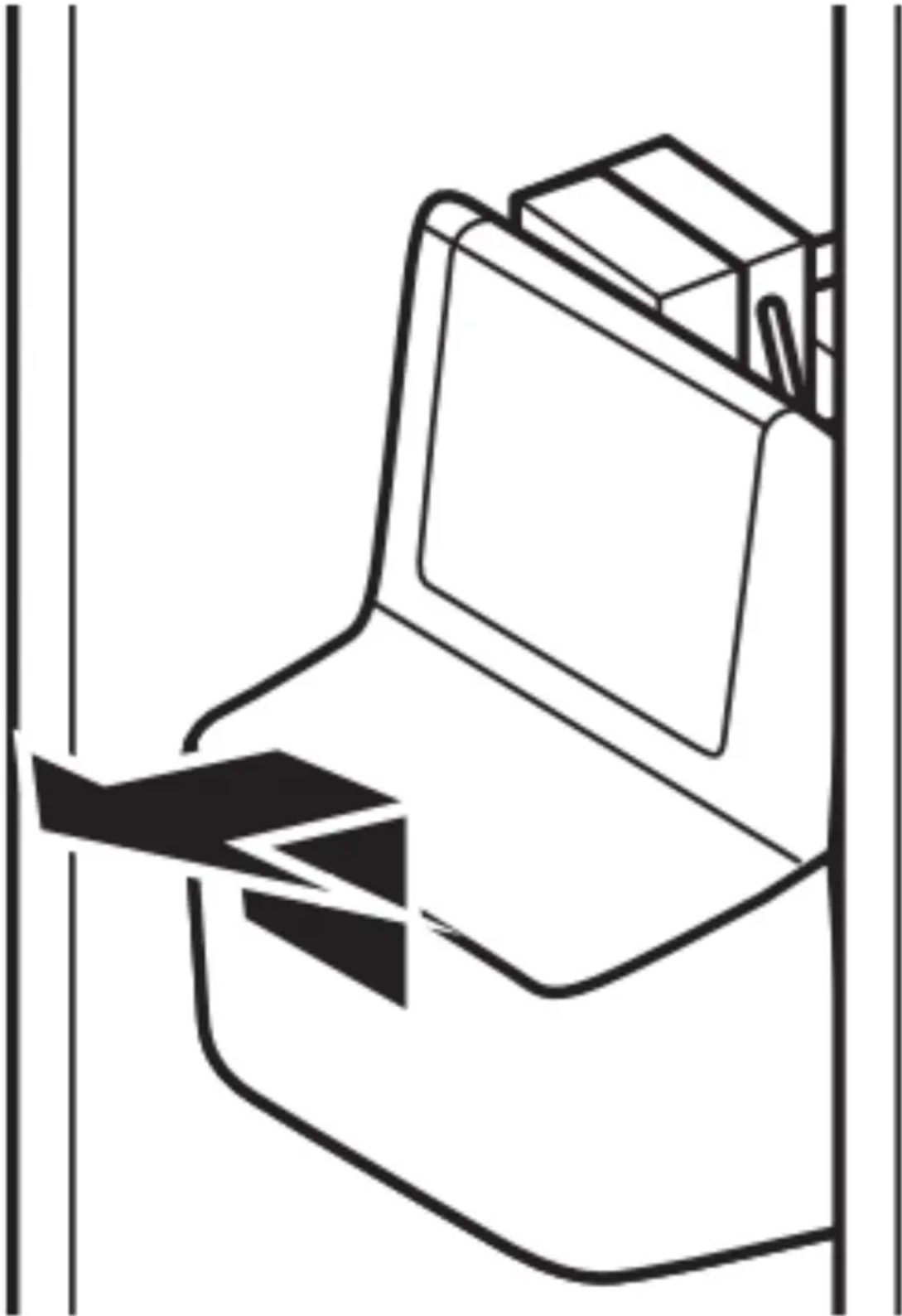

#### Style 4

#### Turning the Ice Maker On/Off:

The On/Off switch is located on the bottom of the ice maker, which can be accessed by lifting and opening the ice maker door.

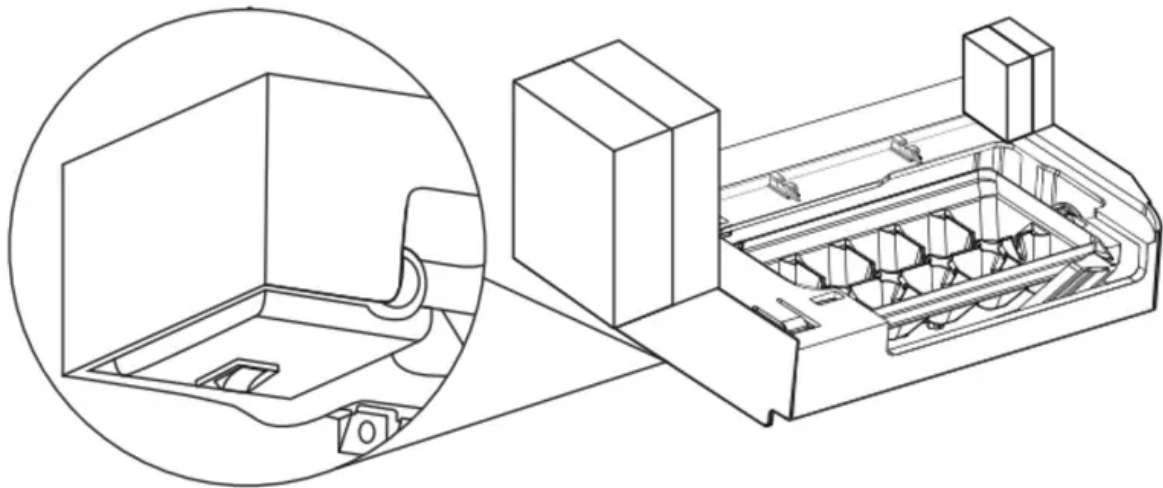

- To turn on the ice maker, lift open the ice maker door, and flip the switch to the On (right) position.
- To manually turn off the ice maker, lift open the ice maker door, and flip the switch to the Off (left) position. Ice can still be dispensed, but no more can be made.

**NOTE:** Your ice maker has an automatic shutoff to keep the storage bin from overflowing during normal operation. As ice is made, the ice cubes will fill the ice storage bin, and the ice cubes will raise the shutoff arm to the Off (arm up) position. When the storage bin is at full capacity, the ice maker will automatically stop ice production, but the ice maker On/Off switch will remain in the On (up) position.

#### **Removing and Replacing the Ice Storage Bin:**

1. Pull the covering panel up from the bottom.
2. Lift the plastic shutoff arm so it clicks into the Off (up) position.
3. Lift up the front of the storage bin and pull it out.
4. Replace the bin by pushing it in all the way or the dispenser will not work.
5. To restart ice production, lower the plastic shutoff arm to the On (down) position. Make sure the door is closed tightly.

#### **Style 5**

##### **Turning the Ice Maker On/Off:**

The ON/OFF switch is located on the right side of the ice maker, which can be accessed by lifting and opening the ice maker door.

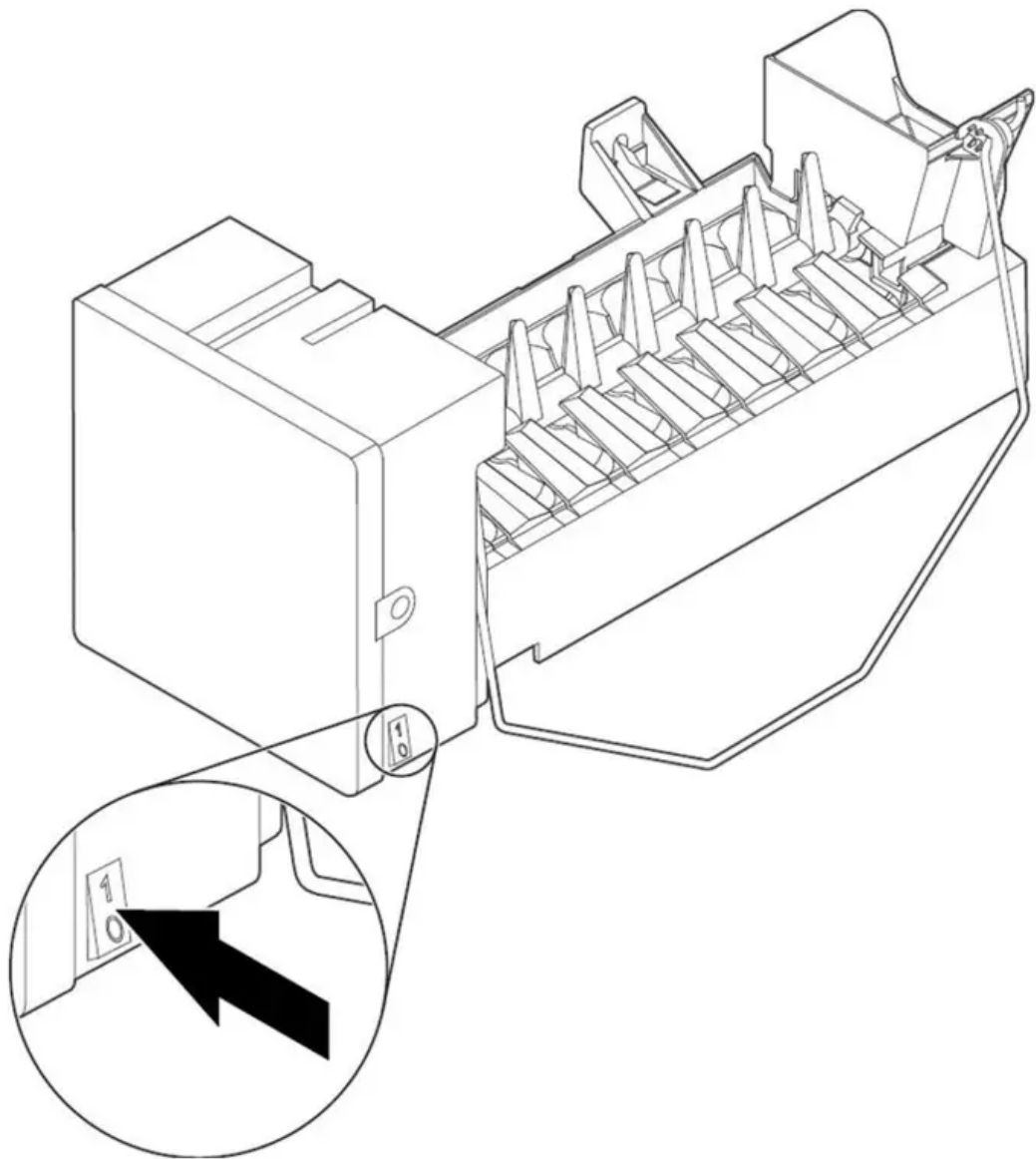

- To turn on the ice maker, lift open the ice maker door, and flip the switch ON/OFF to the ON (I) position.
- To manually turn the ice maker off, lift open the ice maker door, and flip the switch ON/OFF to the OFF (O) position.

**NOTE:** The ice maker has an automatic shutoff to keep the storage bin from overflowing during normal operation. As ice is made, the ice cubes will fill the ice storage bin and the ice cubes will raise the wire shutoff arm up. When the storage bin is at full capacity, the ice maker will automatically stop ice production, but the ice maker ON/OFF rocker switch will remain in the ON (I) position. Do not force the wire shutoff arm up or down.

#### **Removing and Replacing the Ice Storage Bin:**

1. Pull the covering panel up from the bottom.
2. Move the ON/OFF rocker switch to the OFF (O) position.
3. Lift up the front of the storage bin and pull it out.

4. Replace the bin by pushing it in all the way or the dispenser will not work.
5. To restart ice production, move the ON/OFF rocker switch to the ON (I) position Make sure the door is closed tightly.

## **Water Filtration System**

Do not use with water that is microbiologically unsafe or of unknown quality without adequate disinfection before or after the system. Systems certified for cyst reduction may be used on disinfected waters that may contain filterable cysts.

### **Water Filter Status Light**

The water filter status light will help you know when to change your water filter. This is located on the refrigerator control panel. To order a replacement water filter use part number W10295370A (P4RFWB).

#### **Style 1 – Order and Replace status:**

- When the dispenser control panel's water filter status display changes to "Order," this tells you that it is almost time to change the water filter cartridge.
- Replace the water filter cartridge when the water filter status display changes to "Replace."

**NOTE:** If water flow to your water dispenser or ice maker decreases noticeably, change the filter sooner. The filter should be replaced at least every 6 months, depending on your water quality and usage.

#### **Style 2 – Red light status:**

- When the light turns red on the control panel, this tells you that it is time to change the water filter cartridge.
- It is recommended that you replace the filter when the status light turns red or water flow to your water dispenser or ice maker decreases noticeably.

**NOTE:** The filter should be replaced at least every 6 months, depending on your water quality and usage.

### **Resetting the Filter Status**

After changing the water filter, reset the status light.

- **For models with the Options button:**  
Press the Options button to enter Options mode, press Lock to initiate the reset, and then press Measured Fill to confirm that you want to reset the status light. When the system is reset, the "Order" and "Replace" icons will disappear from the display screen.
- **For models with the Filter button:**  
Press and hold the Filter button for 3 seconds to reset the status light. When the system is reset, the "Order" and "Replace" icons will disappear from the display screen.

- **For models with the Temp Setting button:**

The reset button is located on the control panel in the refrigerator compartment. To reset the status light after changing the filter, press Temp Setting within 3 seconds. The status light will change from red to off when the system is reset.

- **For models with the Light and Ice Type buttons:**

Reset the filter status light by pressing and hold Light and Ice Type buttons for 3 seconds. The status light will turn off when the system is reset.

## Changing the Water Filter

### Style 1 – Top-right corner location:

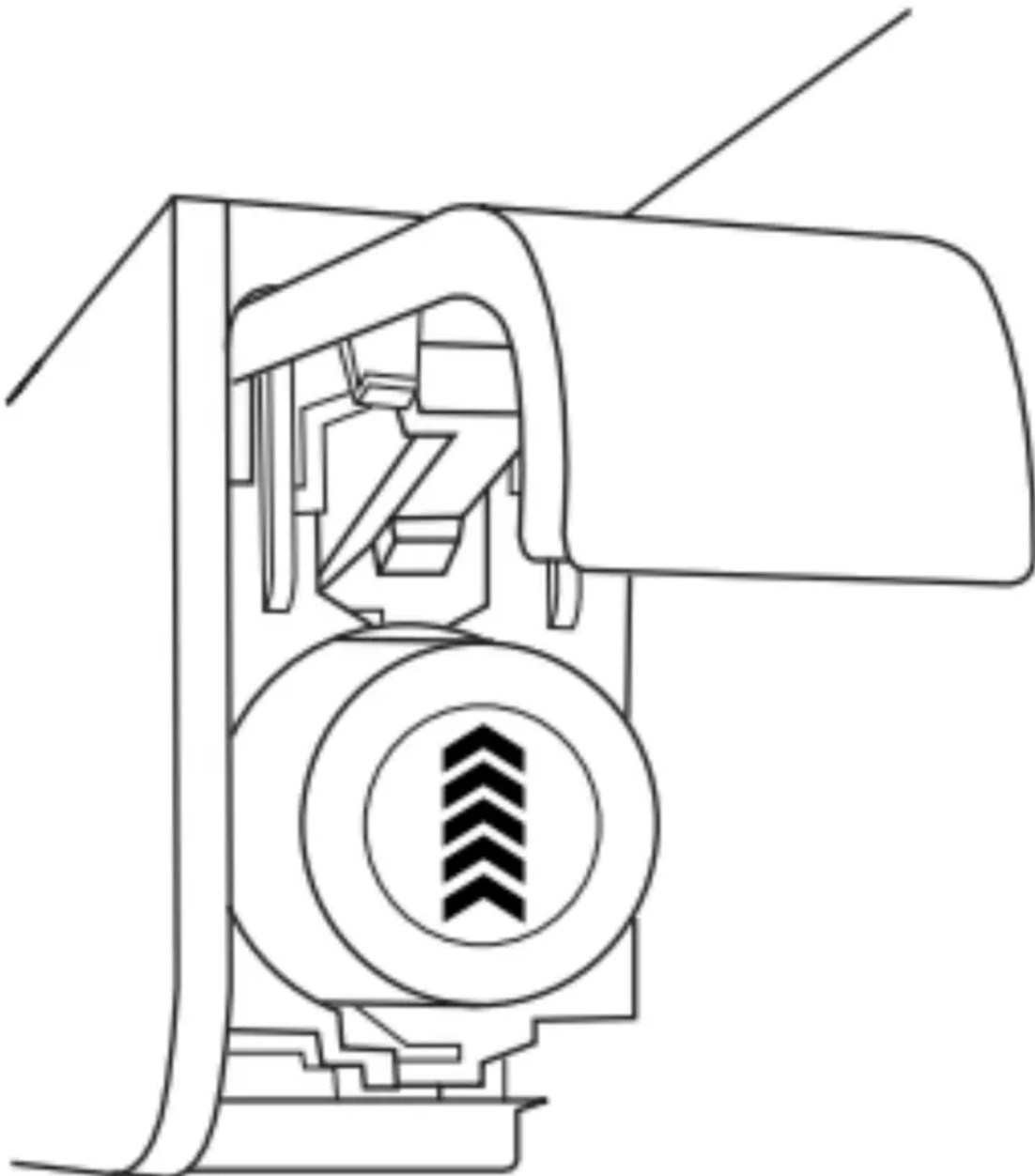

1. Locate the water filter in the top-right corner of the refrigerator compartment.

2. Lift open the filter cover door. The filter will be released and then be ejected as the door is opened.
3. When the door is completely open, pull the filter straight out.  
**NOTE:** There may be some water in the filter. Some spilling may occur. Use a towel to wipe up any spills.
4. Take the new filter out of its packaging and remove the cap.  
Be sure the O-rings are still in place after the cap is removed.

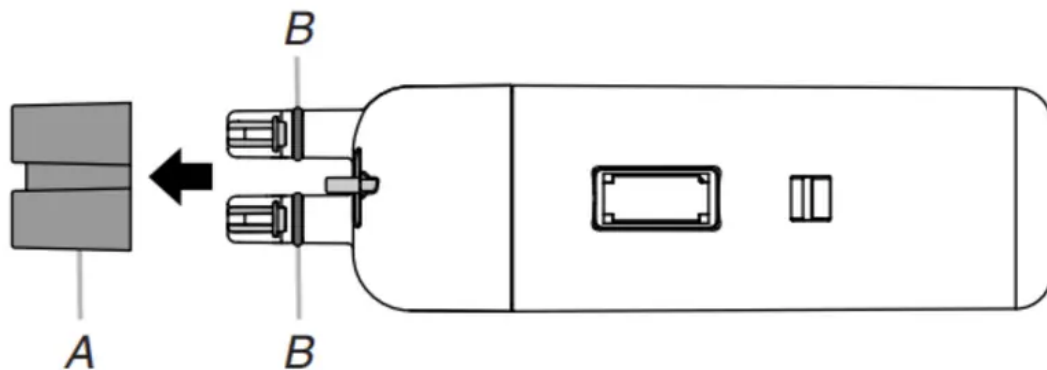

*A. Cap*

*B. O-rings*

5. With the arrow pointing up, align the new filter with the filter housing and slide it into place. The filter cover door will automatically begin to close as the new filter is inserted.
6. Close the filter cover door completely in order to snap the filter into place. You may need to press hard.
7. After changing the filter, reset the filter status light.
8. Flush the water system. See “Water and Ice Dispensers” for details.

**Style 2 – Base grille location (automatic ejection):**

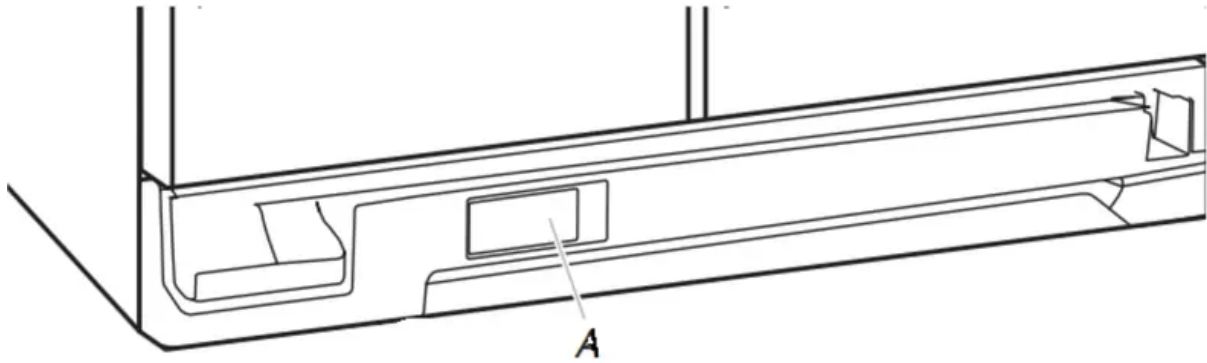

### **A. Water filter cover door**

1. Locate the water filter cover door in the base grille, and pull open the filter door. The filter will be released and then be ejected as the door is opened.
2. When the door is completely open, pull the filter straight out.

**NOTE:** There may be some water in the filter. Some spilling may occur. Use a towel to wipe up any spills.

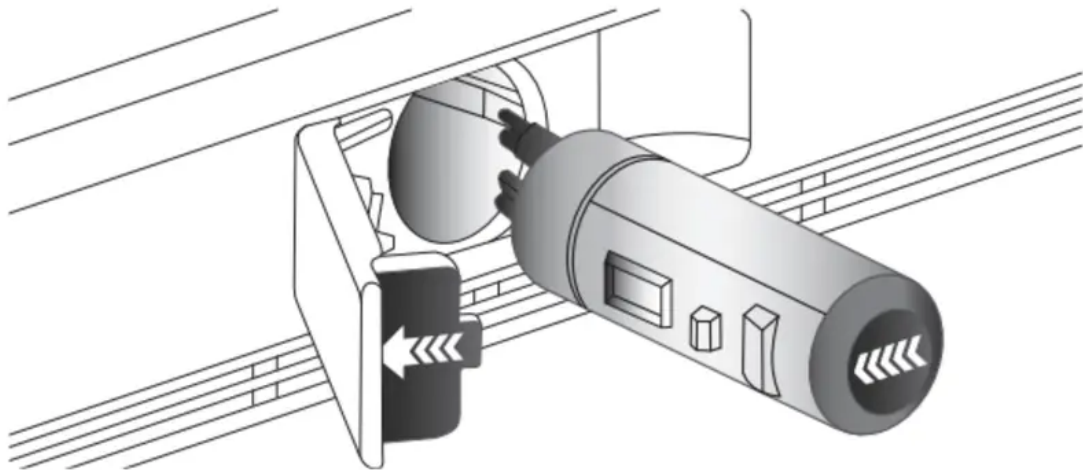

3. Take the new filter out of its packaging and remove the covers from the O-rings. Be sure the O-rings are still in place after the covers are removed.
4. With the arrow pointing to the left (toward the filter cover door's hinge), align the new filter with the filter housing and slide into place. The filter cover door will automatically begin to close as the new filter is inserted.
5. Close the filter cover door completely in order to snap the filter into place. You may need to press hard.
6. Flush the water system. See "Water and Ice Dispensers" for details.

# MAINTENANCE AND CARE

## Cleaning

### **WARNING - Explosion Hazard**

- Risk of Fire or Explosion.
- Flammable Refrigerant Used.
- Do Not Use Mechanical Devices to Defrost Refrigerator.
- Do Not Puncture Refrigerant Tubing.

Both the refrigerator and freezer sections defrost automatically. However, clean both sections about once a month to avoid buildup of odors. Wipe up spills immediately.

**IMPORTANT:** Because air circulates between both sections, any odors formed in one section will transfer to the other. You must thoroughly clean both sections to eliminate odors. To avoid odor transfer and drying out of food, wrap or cover foods tightly.

**NOTE:** Do not use abrasive or harsh cleaners such as window sprays, scouring cleansers, flammable fluids, cleaning waxes, concentrated detergents, bleaches or cleansers containing petroleum products on plastic parts, interior, and door liners or gaskets. Do not use paper towels, scouring pads, or other harsh cleaning tools. Stainless steel models have a coating. Do Not use regular stainless steel cleaning products. Do Not use stainless steel cleaner or polish and use only mild soap, water, and soft microfiber cloth to avoid damage to the stainless steel protective coating. Paper towels scratch and may dull the clear coat of the painted door. To avoid possible damage, use only clean cloths to polish and wipe the door.

1. Unplug refrigerator or disconnect power.
2. Hand-wash, rinse, and dry removable parts and interior surfaces thoroughly. Use a clean sponge or soft cloth and a mild detergent in warm water.
3. Wash stainless steel and painted metal exteriors with a clean sponge or soft cloth and a mild detergent in warm water.
4. There is no need for routine condenser cleaning in normal home operating environments. If the environment is particularly greasy or dusty, or there is significant pet traffic in the home, the condenser should be cleaned every 2 to 3 months to ensure maximum efficiency.

#### **If you need to clean the condenser:**

Remove the base grille. See the "Door Removal" instructions, either in the Owner's Manual or in the separate instruction sheet provided with your refrigerator.

Use a vacuum cleaner with a soft brush to clean the grille, the open areas behind the grille, and the front surface area of the condenser.

Replace the base grille when finished.

5. Plug in refrigerator or reconnect power.

## **WARNING - Explosion Hazard**

- Risk of Fire or Explosion due to Puncture of Refrigerant Tubing;
- Follow Handling Instructions Carefully.
- Flammable Refrigerant Used.

## **Lights**

Not all bulbs will fit your refrigerator. Be sure to replace the bulb with one of the same size, shape, and wattage.

**IMPORTANT:** The light bulbs in both the refrigerator and freezer compartments of your new refrigerator may use LED technology. On some models, the LED light bulbs in the refrigerator, freezer, air tower, and dispenser cannot be changed by yourself. If the lights do not illuminate when the refrigerator and/or freezer door is opened, call for assistance or service. In the U.S.A., call 1-800-253-1301. In Canada, call 1-800-807-6777.

### **Light Styles:**

The dispenser lights are LEDs that cannot be changed.

The interior lights vary by model.

- Some models have mini LEDs that cannot be changed.
- Some models have full-size LED bulbs that can be changed.

To order replacement 2.0 W LED bulbs, use part number W10574850A, and for 3.6 W, use part number W10565137A, or call 1-800-253-1301 (U.S.A.) or 1-800-807-6777 (Canada).

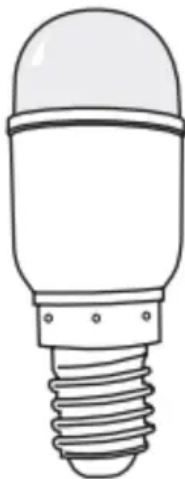

**2.0 watts**

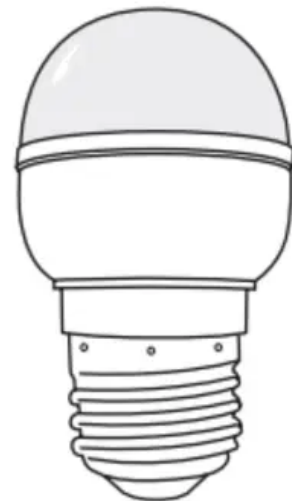

**3.6 watts**

**NOTE:** Some LED replacement bulbs are not recommended for wet/damp environments. The refrigerator and freezer compartments are considered to be wet/damp environments. If

using a brand of LED bulb other than the recommended Whirlpool LED bulb, read and follow all instructions on the replacement bulb's packaging before installing it.

- Some models have interior incandescent 40 W bulbs that can be changed.

**NOTE:** Not all replacement bulbs will fit your refrigerator. Do not use an incandescent bulb in excess of 40 watts.

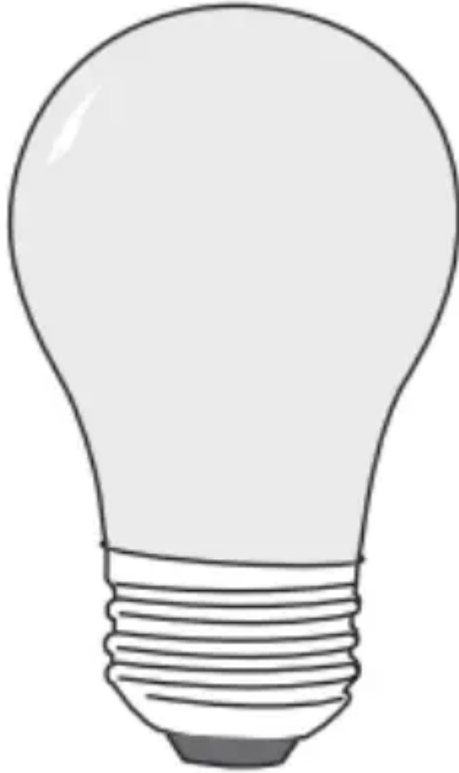

### **To Change a Light Bulb:**

1. Unplug refrigerator or disconnect power.
2. Remove the light shield, as explained in the following sections.  
**NOTE:** To clean the light shield, wash it with warm water and liquid detergent. Before reinstalling, thoroughly rinse and dry the shield.
3. Replace the burned-out light bulb, as explained in the following sections.
4. Reinstall the light shield, as explained in the following sections.
5. Plug in refrigerator or reconnect power.

### **Refrigerator Compartment – Upper Lights**

#### **Light Shield Removal:**

Slide the light shield toward the rear of the refrigerator and remove it from the light housing.

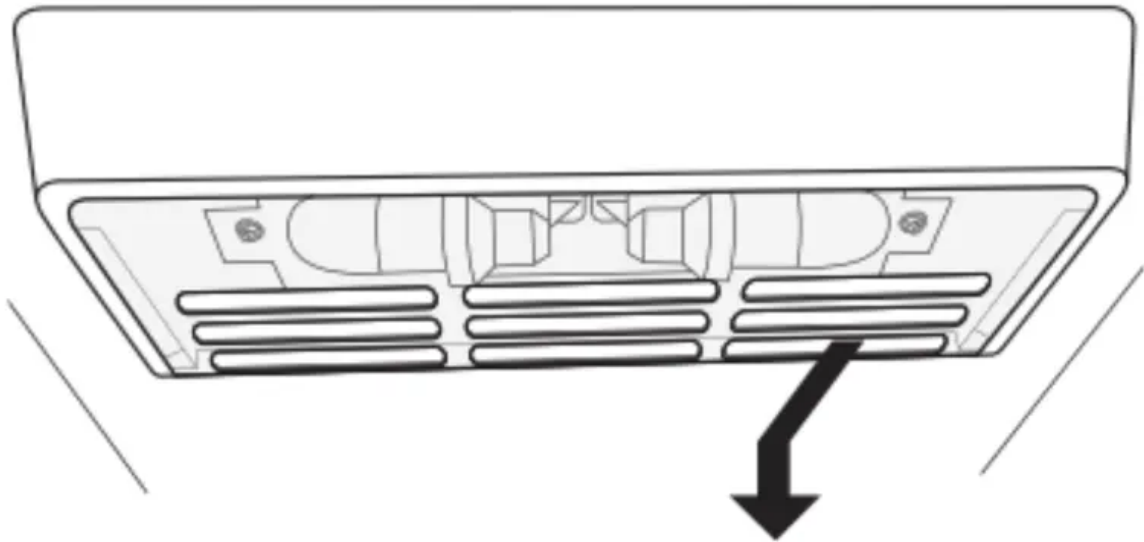

**Replacement Bulb:**

- If the burned-out light is a full-size LED bulb, replace it with a 2.0 W LED bulb.
- If the burned-out light is an incandescent bulb, replace it with an incandescent appliance bulb of the same size, shape, and wattage (40 W maximum).

**Light Shield Reinstallation:**

Align the light shield in the grooves at the bottom edge of the light housing; then slide it forward until it snaps into place.

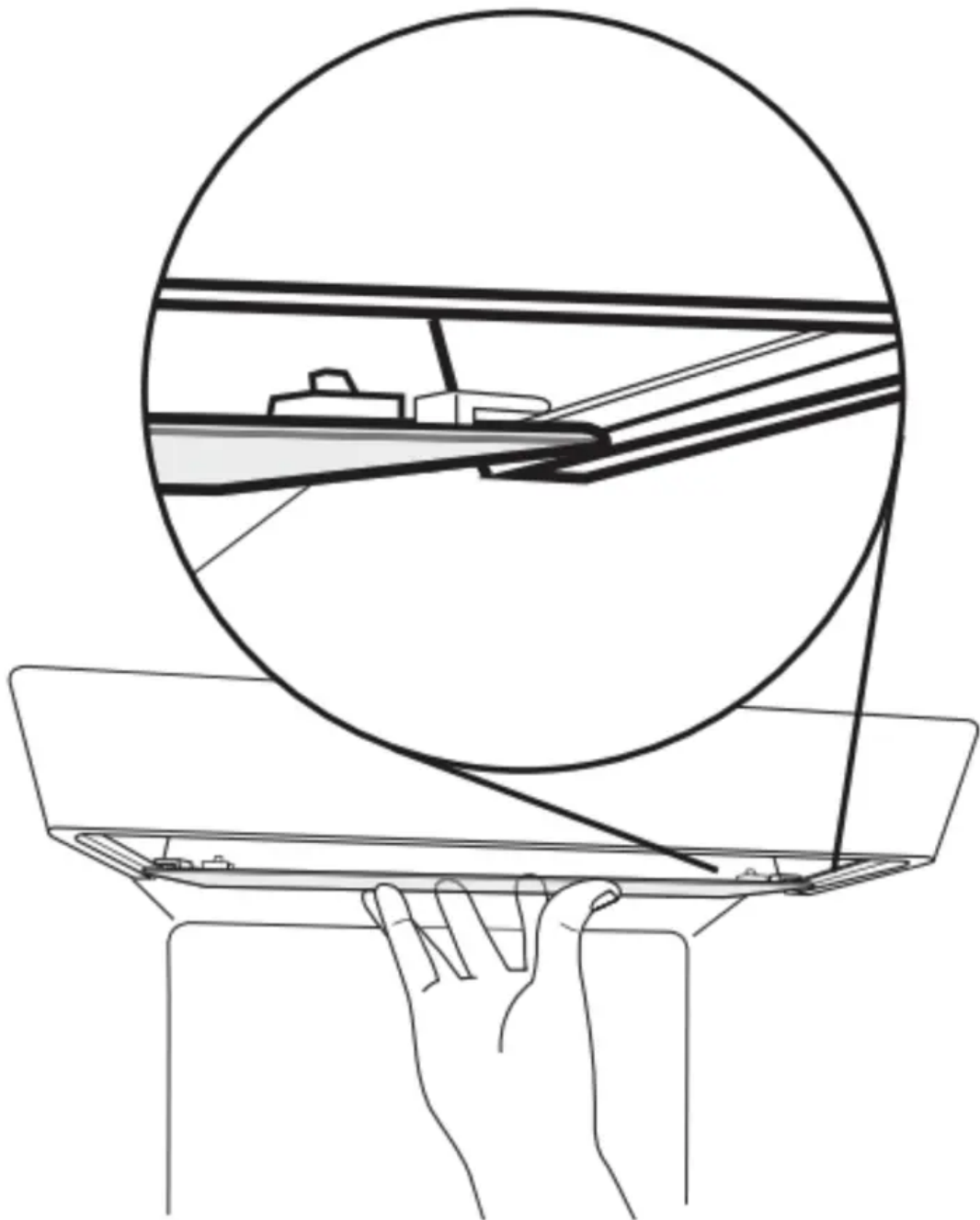

### **Refrigerator Compartment – Lower Lights**

#### **Light Shield Removal:**

Slide the light shield to the right to remove the left end from the wall slots; then pull the right end out of its wall slots.

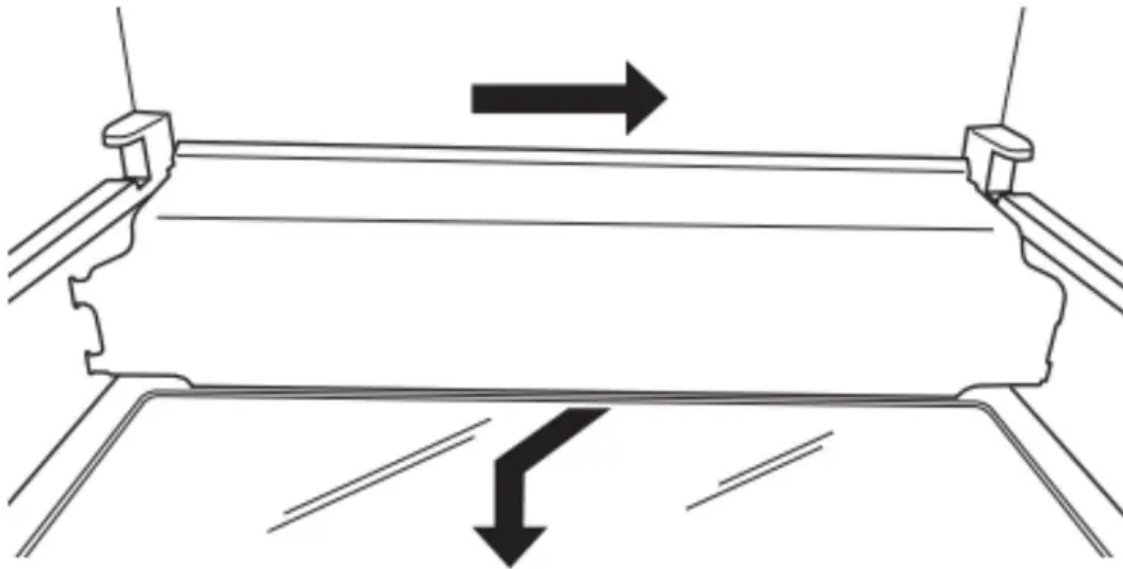

**Replacement Bulb:**

- If the burned-out light is a full-size LED bulb, replace it with a 3.6 W LED bulb.
- If the burned-out light is an incandescent bulb, replace it with an incandescent appliance bulb of the same size, shape, and wattage (40 W maximum).

**Light Shield Reinstallation:**

Place the right end of the light shield into the wall slots; then snap the left end into its wall slots.

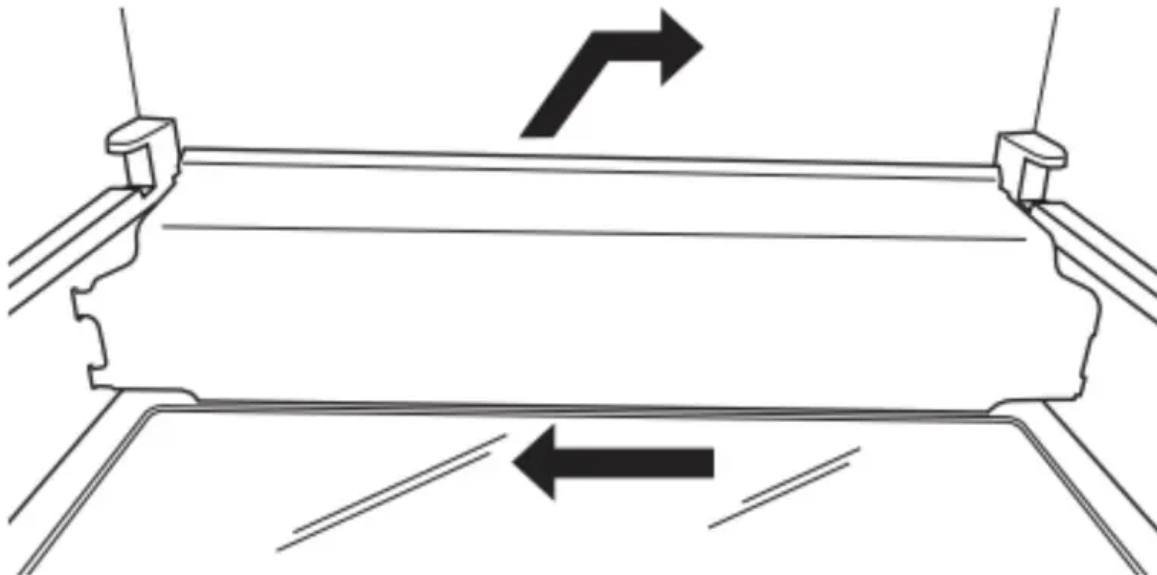

**Freezer Compartment – Upper Light**

**Light Shield Removal:**

Gently squeeze the front and the bottom-rear edge of the light shield to release the tabs from the wall slots; then pull the light shield forward.

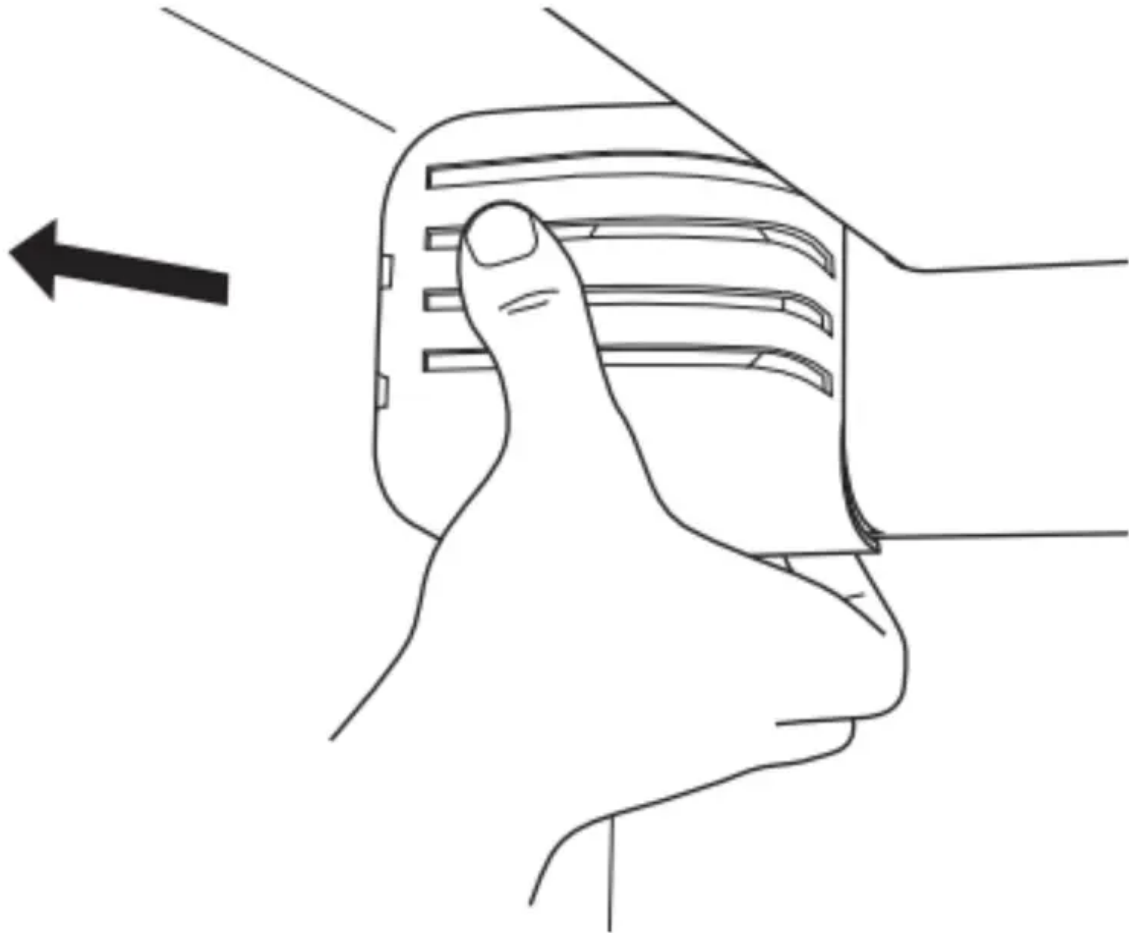

**Replacement Bulb:**

- If the burned-out light is a full-size LED bulb, replace it with a 3.6 W LED bulb.
- If the burned-out light is an incandescent bulb, replace it with an incandescent appliance bulb of the same size, shape, and wattage (40 W maximum).

**Light Shield Reinstallation:**

Align the light shield in its proper position, and snap the tabs into the wall slots.

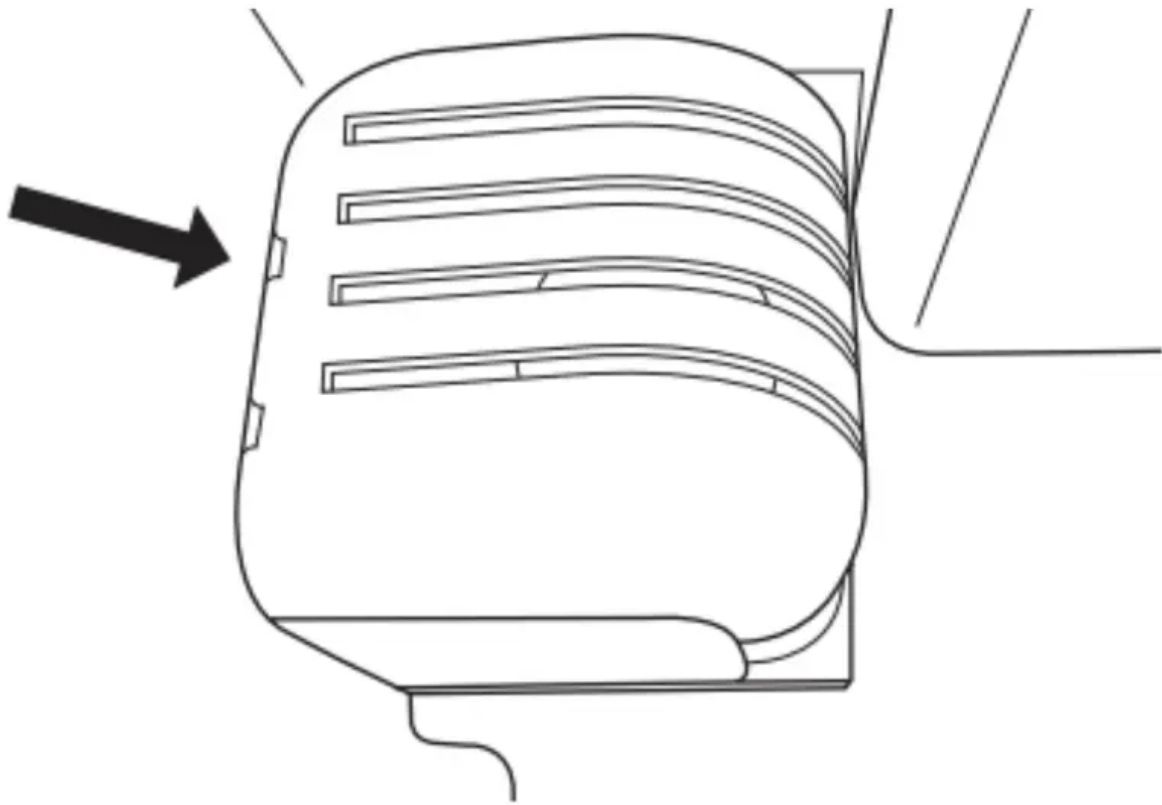

**Freezer Compartment – Lower Light  
Light Shield Removal:**

Slide the light shield to the left to remove the right end from the wall slots; then pull the left end out of its wall slots.

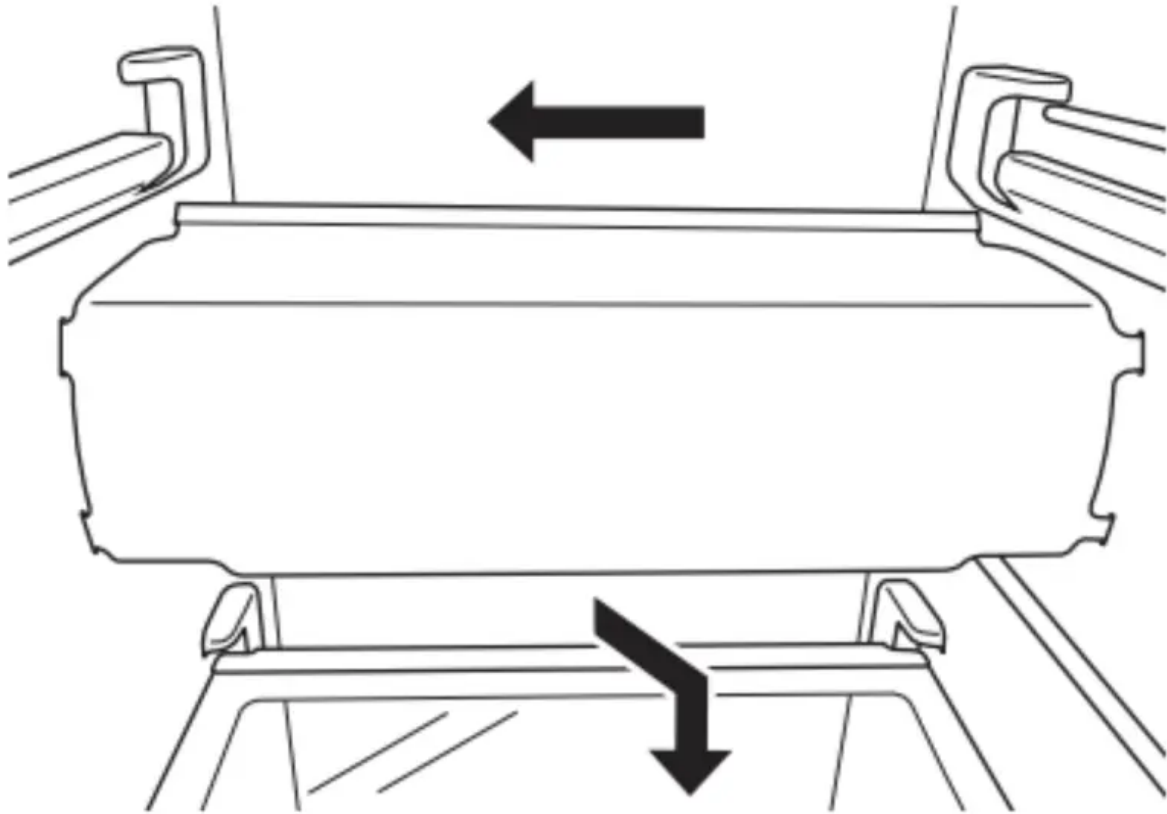

**Replacement Bulb:**

- If the burned-out light is a full-size LED bulb, replace it with a 3.6 W LED bulb.
- If the burned-out light is an incandescent bulb, replace it with an incandescent appliance bulb of the same size, shape, and wattage (40 W maximum).

**Light Shield Reinstallation:**

Place the left end of the light shield into the wall slots; then snap the right end into its wall slots.

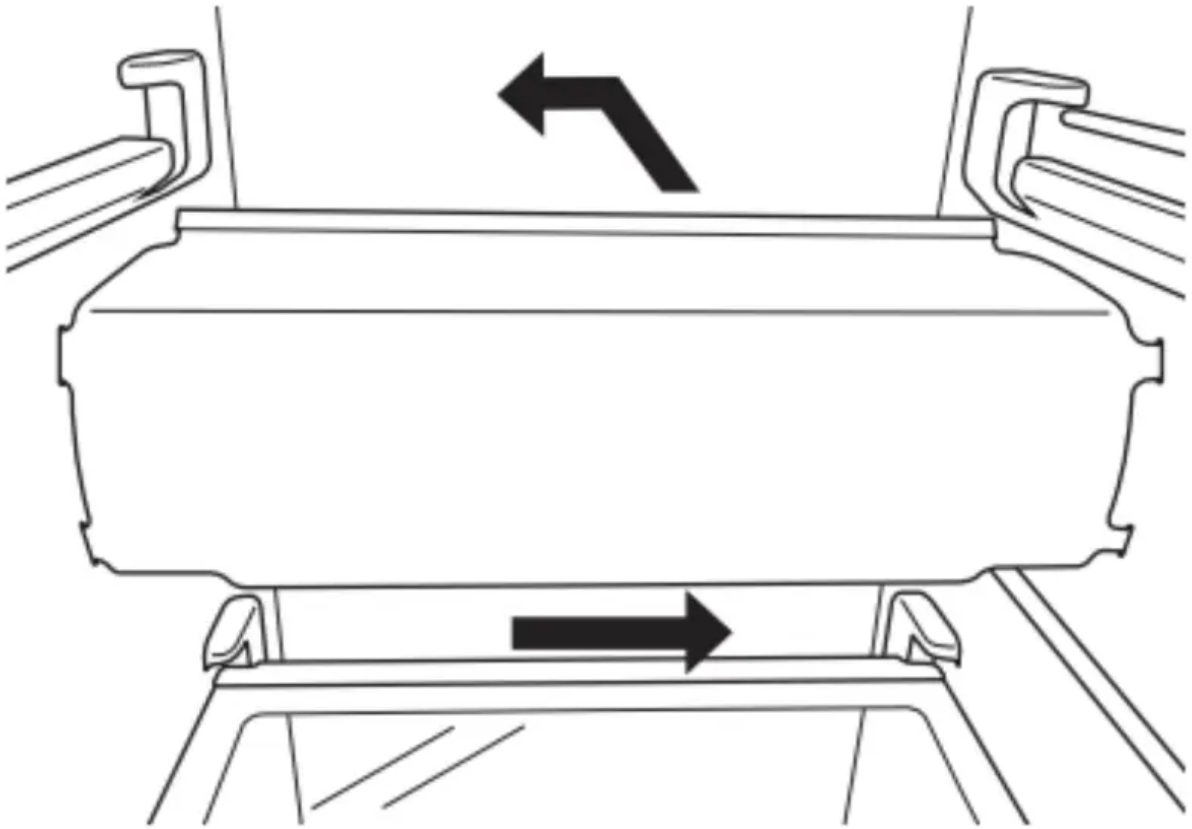

### **Freezer Shelf (number varies by model)**

#### **To Remove and Replace the Bottom Shelf:**

1. Lift up the front and back of the shelf, and remove from the cabinet. Be sure not to remove the retaining rods.
2. Replace the shelf, aligning the rods with the cabinet ribs.  
Apply a little pressure on the shelf to attach the rods to the ribs of the cabinet.

#### **To Remove and Replace the Mid and Top Shelf:**

1. With your hand, push the shelf from bottom to top until it is released from the holding rod. Pull the shelf until it is released from the rear rod. Remove from the cabinet.
2. To replace the shelf:  
Replace rods into the support holes. Push the rods down so they click into the holes. Identify the front and rear trim of the shelf.

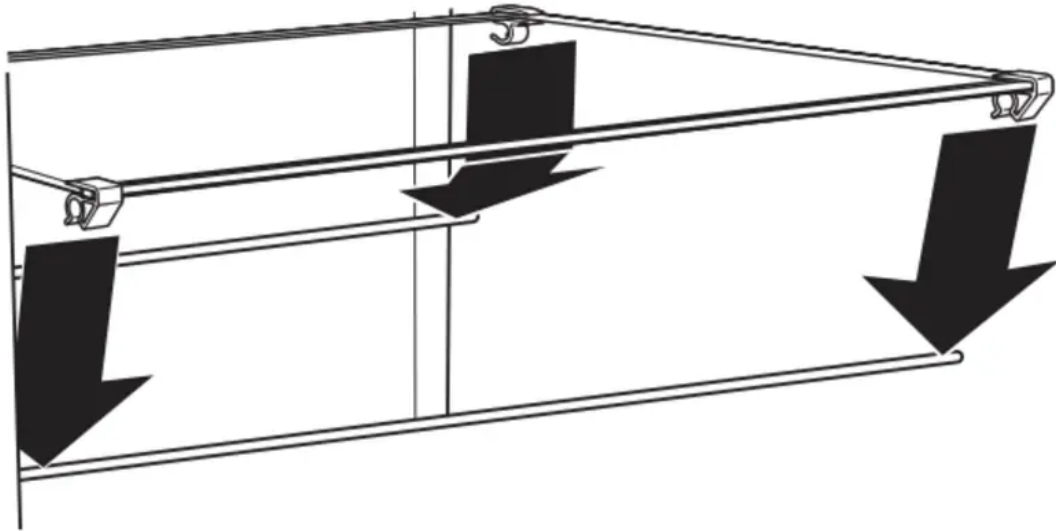

Place the rear trim on the rear rod and push the shelf so it clicks the rod into the rear trim. (Keep the front raised while pushing).

Lower the front of the shelf until the front trim is on the rod and push the shelf down so it clicks the rod into the front trim.

**NOTE:** Be sure that both sides of the shelf are positioned evenly in the shelf support holes and the shelf is secure.

## Vacation and Moving Care

### Vacations

#### If You Choose to Leave Refrigerator On While You Are Away:

1. Use up any perishables and freeze other items.
2. If your refrigerator has an automatic ice maker and is connected to the household water supply, turn off the water supply to the refrigerator. Property damage can occur if the water supply is not turned off.
3. If you have an automatic ice maker, turn off the ice maker.  
**NOTE:** Depending on your model, raise the wire shutoff arm to Off (up) position or press the switch to Off.
4. Empty the ice bin.

#### If You Choose to Turn Refrigerator Off Before You Leave:

1. Remove all food from the refrigerator.
2. If your refrigerator has an automatic ice maker:  
Turn off the water supply to the ice maker at least one day ahead of time.  
When the last load of ice drops, raise the wire shutoff arm to the Off (up) position or move the switch to the Off setting.

3. Depending on the model, turn the refrigerator control to Off or turn cooling off. See “Control Descriptions” in the Quick Start Guide.
4. Unplug refrigerator or disconnect power.
5. Clean, wipe, and dry thoroughly.
6. Tape rubber or wood blocks to the tops of both doors to prop them open far enough for air to get in. This stops odor and mold from building up.

## **Moving**

When you are moving your refrigerator to a new home, follow these steps to prepare it for the move.

1. If your refrigerator has an automatic ice maker:  
Turn off the water supply to the ice maker at least one day ahead of time.  
Disconnect the water line from the back of the refrigerator.  
When the last load of ice drops, raise the wire shutoff arm to the Off (up) position or move the switch to the Off setting.
2. Remove all food from the refrigerator and pack all frozen food in dry ice.
3. Empty the ice bin.
4. Depending on the model, turn the refrigerator control to Off or turn cooling off. See “Control Descriptions” in the Quick Start Guide.
5. Unplug refrigerator or disconnect power.
6. Clean, wipe, and dry thoroughly.
7. Take out all removable parts, wrap them well, and tape them together so they don't shift and rattle during the move.
8. Depending on the model, raise the front of the refrigerator so it rolls more easily, or screw in the leveling legs so they don't scrape the floor. See “Adjust the Doors” or “Door Removal, Leveling and Alignment” in the online Feature Guide.
9. Tape the doors closed and tape the power cord to the back of the refrigerator.

When you get to your new home, put everything back and refer to the Installation Instructions for preparation instructions. Also, if your refrigerator has an automatic ice maker, remember to reconnect the water supply to the refrigerator.

## **TROUBLESHOOTING**

### **WARNING - Electrical Shock Hazard**

- Plug into a grounded 3 prong outlet.
- Do not remove ground prong.
- Do not use an adapter.

- Do not use an extension cord.
- Failure to follow these instructions can result in death, fire, or electrical shock.



| GENERAL OPERATION                           | Possible Causes and/or Recommended Solutions   |
|---|--|
| <p><b>Refrigerator will not operate</b></p> | <ul style="list-style-type: none"> <li>• <b>Not connected to an electrical supply</b> - Plug the power cord into a grounded 3 prong outlet. Do not use an extension cord.</li> <li>• <b>No power to the electrical outlet</b> - Plug in a lamp to see if the outlet is working.</li> <li>• <b>Household fuse has blown or circuit breaker has tripped</b> - Replace the fuse or reset the circuit breaker. If the problem continues, contact a licensed electrician.</li> <li>• <b>New installation</b> - Following installation, allow 24 hours for the refrigerator and freezer to cool completely.</li> </ul> <p><b>NOTE:</b> Adjusting the temperature control(s) to the coldest setting will not cool either compartment (refrigerator or freezer) more quickly.</p>  |
| <p><b>Motor seems to run too much</b></p>   | <ul style="list-style-type: none"> <li>• <b>Your new refrigerator has an energy-efficient motor</b> - The refrigerator may run longer than you're used to because the compressor and fans operate at lower speeds that are more energy-efficient. This is normal.</li> </ul> <p><b>NOTE:</b> Your refrigerator may run even longer if the room is warm, a large load of food is added, the doors are opened often, or if a door has been left open.</p>  |
| <p><b>Refrigerator seems noisy</b></p>      | <p>The compressor in your new refrigerator regulates temperature more efficiently and uses less energy than older models. During various stages of operation, you may hear normal operating sounds that are unfamiliar.</p> <p><b>The following noises are normal:</b></p> <ul style="list-style-type: none"> <li>• <b>Buzzing/Clicking</b> - Heard when the water valve opens and closes to dispense water or fill the ice maker. If the refrigerator is connected to a water line, this is normal. If the refrigerator is not connected to a water line, turn off the ice maker.</li> <li>• <b>Cracking/Crashing</b> - Heard when ice is ejected from the ice maker mold.</li> <li>• <b>Popping</b> - Heard when the inside walls contract/expand, especially during initial cool down.</li> <li>• <b>Pulsating/Whirring</b> - Heard when the fans/compressor adjust to optimize performance during normal operation.</li> </ul> |



| GENERAL OPERATION                     | Possible Causes and/or Recommended Solutions   |
|---------------------------------------|--|
|                                       | <ul style="list-style-type: none"> <li>• <b>Rattling</b> - Heard when water passes through the water line, or due to the flow of refrigerant.<br/>Rattling may also come from items placed on top of the refrigerator.</li> <li>• <b>Water running or gurgling</b> - Heard when ice melts during the defrost cycle and water runs into the drain pan.</li> <li>• <b>Sizzling</b> - Heard when water drips onto the heater during the defrost cycle.</li> </ul>   |
| <p><b>Temperature is too warm</b></p> | <ul style="list-style-type: none"> <li>• <b>New installation</b> - Following installation, allow 24 hours for the refrigerator and freezer to cool completely.<br/><b>NOTE:</b> Adjusting the temperature control(s) to the coldest setting will not cool either compartment (refrigerator or freezer) more quickly.</li> <li>• <b>Doors are opened often or not closed completely</b> - This allows warm air to enter the refrigerator. Minimize door openings, keep the doors fully closed, and make sure both doors are properly sealed.</li> <li>• <b>Air vents are blocked</b> - Remove items that are immediately in front of the vents.</li> <li>• <b>Large amount of warm food recently added</b> - Allow several hours for the refrigerator to return to its normal temperature.</li> <li>• <b>Controls are not set correctly for the surrounding conditions</b> - Adjust the controls to a colder setting. Check the temperature again in 24 hours.</li> </ul> |
| <p><b>Temperature is too cold</b></p> | <ul style="list-style-type: none"> <li>• <b>Controls are not set correctly for the surrounding conditions</b> - Adjust the controls to a warmer setting. Check the temperature again in 24 hours.</li> <li>• <b>Top refrigerator shelf is colder than lower shelves</b> - On some models, air from the freezer enters the refrigerator compartment through vents near the top refrigerator shelf. As a result, the top shelf can be slightly colder than lower shelves.</li> <li>• <b>Air vents are blocked</b> - Remove items that are immediately in front of the vents.</li> </ul>  |



| GENERAL OPERATION   | Possible Causes and/or Recommended Solutions  |
|---|---|
| <p><b>Interior moisture buildup</b></p>                     | <p><b>NOTE:</b> Some moisture buildup is normal. Clean with a soft dry cloth.</p> <ul style="list-style-type: none"> <li>• <b>Room is humid</b> - A humid environment contributes to moisture buildup. Use the refrigerator only in an indoor location, with as little humidity as possible.</li> <li>• <b>Doors are opened often or not closed completely</b> - This allows humid air to enter the refrigerator. Minimize door openings, keep the doors fully closed, and make sure both doors are properly sealed.</li> </ul>   |
| <p><b>Interior lights do not work</b></p>                   | <ul style="list-style-type: none"> <li>• <b>Doors have been open for an extended period of time</b> - Close the doors to reset the lights.</li> <li>• <b>Light bulb is loose in the socket or has burned out</b> - On models with incandescent interior light bulbs, tighten or replace the bulb. See the “Lights” section.</li> </ul> <p><b>NOTE:</b> On models with LED lights, call for assistance or service if the interior lights do not illuminate when either door is opened. See the Warranty for contact information.</p>   |
| <p><b>Dispenser lights do not work (on some models)</b></p> | <ul style="list-style-type: none"> <li>• <b>Dispenser light is turned off</b> - On some models, if the dispenser light is set to Off, the light will turn on only when a dispenser pad/lever is pressed. If you want the dispenser light to stay on continuously, select a different setting. See the “Water and Ice Dispensers” section.</li> <li>• <b>Dispenser light is set to Auto or Night Light</b> - On some models, if the dispenser light is set to Auto or Night Light, make sure the dispenser light sensor is not blocked. See the “Water and Ice Dispensers” section.</li> </ul> <p><b>NOTE:</b> On models with LED lights, call for assistance or service if the dispenser lights do not operate correctly. See the Warranty for contact information.</p> |

**WARNING - Explosion Hazard**

- Use nonflammable cleaner.
- Failure to do so can result in death, explosion, or fire.



| DOORS AND LEVELING                   | Possible Causes and/or Recommended Solutions   |
|--------------------------------------|--|
| Doors are difficult to open          | <ul style="list-style-type: none"> <li>• <b>Gaskets are dirty or sticky</b> - Clean the gaskets and contact surfaces with mild soap and warm water. Rinse and dry with a soft cloth.</li> </ul>  |
| Doors will not close completely      | <ul style="list-style-type: none"> <li>• <b>Door is blocked open</b> - Move food packages away from the door. Make sure all bins and shelves are in their correct positions. Make sure all packaging materials have been removed.</li> </ul>           |
| Doors appear to be uneven            | <ul style="list-style-type: none"> <li>• <b>Doors need to be aligned, or refrigerator needs to be leveled</b> - See the leveling and door alignment instructions.</li> </ul>   |
| Refrigerator rocks and is not stable | <ul style="list-style-type: none"> <li>• <b>Refrigerator is not level</b> - To stabilize the refrigerator, remove the base grille and lower the leveling feet until they touch the floor. See the leveling and door alignment instructions.</li> </ul> |

**WARNING - Cut Hazard**

- Use a sturdy glass when dispensing ice.
- Failure to do so can result in cuts.



| ICE AND WATER  | Possible Causes and/or Recommended Solutions   |
|--|--|
| <p>Ice maker is not producing ice, not producing enough ice, or producing small/hollow ice</p> | <ul style="list-style-type: none"> <li>• <b>Refrigerator is not connected to a water supply, or the water supply shut-off valve is not fully turned on</b> - Connect the refrigerator to a water supply and make sure the water shut-off valve is fully open.</li> <li>• <b>Kink in the water source line</b> - A kink in the water line can reduce water flow, resulting in decreased ice production, small ice cubes, and/or hollow or irregularly-shaped ice. Straighten the water line.</li> <li>• <b>Ice maker is not turned on</b> - Turn on the ice maker. See the “Ice Maker and Storage Bin” section.</li> <li>• <b>New installation</b> - After connecting the refrigerator to a water source, flush the water system.<br/>(See the “Water and Ice Dispensers” section.) Wait 24 hours for ice production to begin. Wait 72 hours for full ice production. Discard the first three batches of ice produced.</li> <li>• <b>Large amount of ice was recently removed</b> - Allow sufficient time for the ice maker to produce more ice.</li> <li>• <b>Ice is jammed in the ice maker ejector arm</b> - Remove ice from the ejector arm using a plastic utensil.</li> <li>• <b>Inadequate water pressure</b> - Verify that the household has adequate water pressure. See the “Water Supply Requirements” section.</li> <li>• <b>Water filter is installed incorrectly</b> - Make sure the filter is properly installed. See the “Water Filtration System” section.</li> <li>• <b>A reverse osmosis water filtration system is connected to your cold water supply</b> - This can decrease water pressure. See the “Water Supply Requirements” section.</li> </ul> <p><b>NOTE:</b> If questions remain regarding water pressure, contact a licensed, qualified plumber.</p> |
| <p>Ice dispenser will not operate properly</p>   | <ul style="list-style-type: none"> <li>• <b>Doors not closed completely</b> - Make sure both doors are firmly closed. (On some models, only the freezer door must be closed in order to operate the dispenser.)</li> <li>• <b>New installation</b> - After connecting the refrigerator to a water source, flush the water system.<br/>(See the “Water and Ice Dispensers” section.) Wait 24 hours for</li> </ul>   |



| ICE AND WATER  | Possible Causes and/or Recommended Solutions  |
|--|---|
|  | <p>ice production to begin. Wait 72 hours for full ice production. Discard the first three batches of ice produced.</p> <ul style="list-style-type: none"> <li>• <b>Ice maker is not turned on, or ice bin is not installed correctly</b> - Turn on the ice maker and make sure the ice storage bin is firmly in position. See the “Ice Maker and Storage Bin” section.</li> <li>• <b>Ice is clogged or frozen together in the ice storage bin, or ice is blocking the ice delivery chute</b> - Remove or separate the clogged ice, using a plastic utensil if necessary. Clean the ice delivery chute and the bottom of the ice storage bin using a warm damp cloth, then dry both thoroughly. To avoid clogging and to maintain a fresh supply of ice, empty the storage bin and clean both the storage bin and the delivery chute every 2 weeks.</li> <li>• <b>Wrong ice has been added to the storage bin</b> - Use only ice cubes produced by the current ice maker.</li> <li>• <b>Dispenser is locked</b> - Unlock the dispenser. See the “Water and Ice Dispensers” section.</li> <li>• <b>Ice dispenser jams while dispensing crushed ice</b> - For models with the ice storage bin on the door, temporarily switch from crushed ice to cubed ice to clear the jam.</li> <li>• <b>Dispenser pad/lever has been pressed too long</b> - Ice will automatically stop dispensing. Wait a few minutes for the dispenser to reset, then resume dispensing. Take large amounts of ice directly from the ice bin, not through the dispenser.</li> <li>• <b>Water pressure to the home is not at or above 30 psi (207 kPa)</b> - The water pressure to the home affects the flow from the dispenser. See the “Water Supply Requirements” section.</li> <li>• <b>Water filter is clogged or incorrectly installed</b> - Replace filter or reinstall it correctly. See the “Water Filtration System” section.</li> </ul> |
| <p><b>Ice or water has an off-taste, odor, or gray color</b></p> | <ul style="list-style-type: none"> <li>• <b>New plumbing connections</b> - New plumbing connections can result in off-flavored or discolored ice or water. This problem should go away over time.</li> <li>• <b>Ice has been stored too long</b> - Discard the ice and wash the ice bin. Allow 24 hours for the ice maker to produce new ice.</li> </ul>  |



| ICE AND WATER   | Possible Causes and/or Recommended Solutions   |
|---|--|
|   | <ul style="list-style-type: none"> <li>• <b>Odor has transferred from food</b> - Use airtight moisture-proof packaging to store food.</li> <li>• <b>Use of non-recommended water supply line</b> - Odors and tastes can transfer from certain materials used in non-recommended water supply lines. Use only a recommended water supply line. See the “Water Supply Requirements” section.</li> <li>• <b>There are minerals (such as sulfur) in the water</b> - A water filter may need to be installed in order to remove the minerals.</li> <li>• <b>Water filter was recently installed or replaced</b> - Gray or dark discoloration in ice or water indicates that the water filtration system needs additional flushing. See the “Water and Ice Dispensers” section.</li> </ul>   |
| <p><b>Water dispenser will not operate properly</b></p> | <ul style="list-style-type: none"> <li>• <b>Doors not closed completely</b> - Make sure both doors are firmly closed. (On some models, only the freezer door must be closed in order to operate the dispenser.)</li> <li>• <b>Refrigerator is not connected to a water supply, or the water supply shut-off valve is not turned on</b> - Connect the refrigerator to a water supply and make sure the water shut-off valve is fully open.</li> <li>• <b>Kink in the water source line</b> - A kink in the water line can reduce water flow to the dispenser. Straighten the water line.</li> <li>• <b>Water pressure to the home is not at or above 30 psi (207 kPa)</b> - The water pressure to the home affects the flow from the dispenser. See the “Water Supply Requirements” section.</li> <li>• <b>New installation</b> - After connecting the refrigerator to a water source, flush the water system. See the “Water and Ice Dispensers” section.</li> <li>• <b>Dispenser is locked</b> - Unlock the dispenser. See the “Water and Ice Dispensers” section.</li> <li>• <b>Water filter is clogged or incorrectly installed</b> - Replace filter or reinstall it correctly. See the “Water Filtration System” section.</li> <li>• <b>A reverse osmosis water filtration system is connected to your cold water supply</b> - This can decrease water pressure. See the “Water Supply Requirements” section.</li> </ul> |



| ICE AND WATER  | Possible Causes and/or Recommended Solutions  |
|--|---|
|  | <p><b>NOTE:</b> If questions remain regarding water pressure, contact a licensed, qualified plumber.</p>  |
| <p><b>Water is leaking or dripping from the dispenser</b></p>              | <p><b>NOTE:</b> After dispensing, a few additional drops of water are normal.</p> <ul style="list-style-type: none"> <li>• <b>Glass was not held under the dispenser long enough</b> - Hold the glass under the dispenser for 2 to 3 seconds after releasing the dispenser pad/lever.</li> <li>• <b>New installation, or water filter was recently installed or replaced</b> - Air in the water lines causes the water dispenser to drip. Flush the water system to remove the air in the water lines. See the “Water and Ice Dispensers” section.</li> <li>• <b>Residual ice in the dispenser chute is melting</b> - Make sure the ice chute is free of ice shavings or pieces.</li> </ul>   |
| <p><b>Water is leaking from the back of the refrigerator</b></p>           | <ul style="list-style-type: none"> <li>• <b>Water line connections are not fully tightened</b> - Make sure all connections are firmly tightened. See the “Connect Water Supply” section.</li> </ul>   |
| <p><b>Water from the dispenser is not cool enough (on some models)</b></p> | <p><b>NOTE:</b> Water from the dispenser is chilled to 50°F (10°C).</p> <ul style="list-style-type: none"> <li>• <b>New installation</b> - Allow 24 hours after installation for the water supply to cool completely.</li> <li>• <b>Recently dispensed a large amount of water</b> - Allow 24 hours for the new water supply to cool completely.</li> <li>• <b>Water has not been recently dispensed</b> - The first glass of water may not be cool. Discard the first glass of water dispensed.</li> <li>• <b>Refrigerator is not connected to a cold water pipe</b> - Make sure the refrigerator is connected to a cold water pipe. See the “Water Supply Requirements” section.</li> </ul> |

**Warning**

This content is compiled from multiple sources and is provided for reference purposes only. It may not be complete or fully applicable to all situations. If you are unable to resolve your issue, please contact the product manufacturer or an authorized service provider for official support.



