

User Manual Food Slicer Machine

Parts Identification

Before using your Food Sheer for the first time, you should become familiar with all of the parts. Read all Instructions and Safeguards carefully.

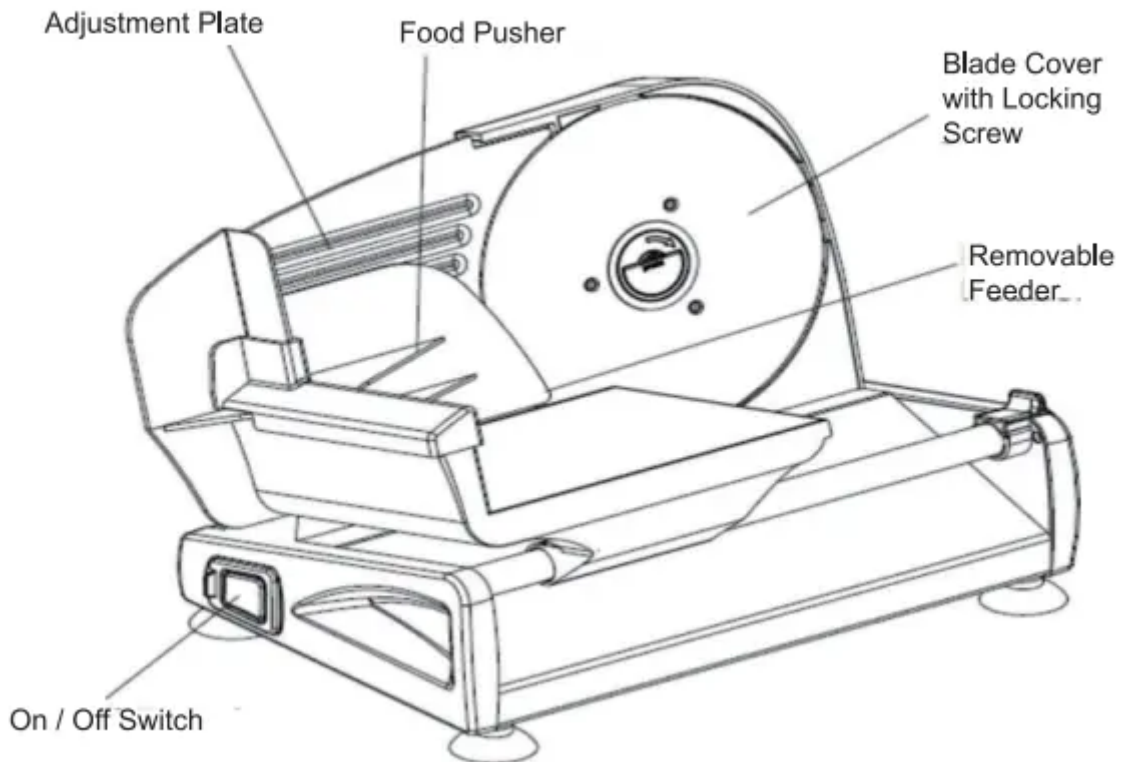

Thickness Adjustment Knob (on the rear side of unit)

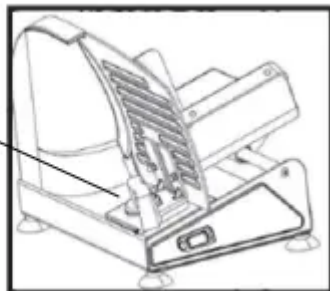

Detachable Metal Rod Release Button

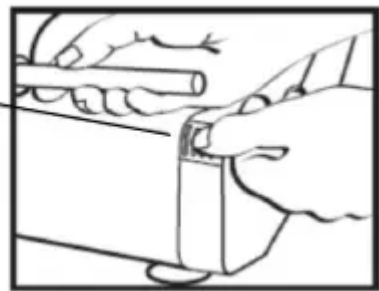

Assembly Instructions

1. Position sheer on a clean, dry, smooth surface.
2. Slice food pusher onto the top of feeder.
3. Set thickness control knob for desired thickness. Turn knob clockwise for thicker slices and counterclockwise for thinner slices.

4. Slip a plate in the back area to catch food.
5. Make sure the blade is locked/tightened.

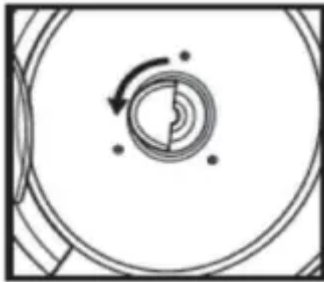

Slicing

CAUTION: Always use feeder and food pusher. It is recommended to disassemble and wash the detachable/ removable parts before first use.

1. Plug into 120 volt AC outlet.
2. Place food on tray.
3. Press safety button and keep depressed. Then push ON/OFF button. For some slicers, motor will only operate when the ON button is pressed and the safety switch is engaged.

NOTE: Some slicers also have a PULSE function on the switch. This function is labeled with “I”. The ON function is labeled with “II” and the OFF function with “O”.

4. Hold food pusher with right hand, keeping thumb protected behind thumb guard. Slide food pusher forward toward blade. Move tray back and forth steadily. Keep food gently pressed against guide for even
5. When finished slicing, unplug unit. For safety and blade protection when storing, turn knob to align thickness guide with blade.

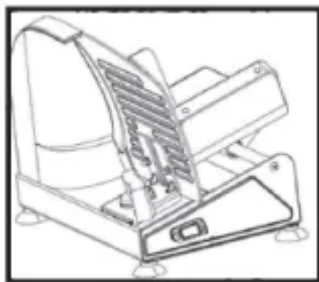

Slicing Tips

To slice meats wafer thin, chill thoroughly before slicing.

Meats should be boneless. Fruits should be free of seeds.

Foods with an uneven texture, like fish and thin steaks, are often difficult to slice. Partially freeze before slicing.

Hot Roasts: Beef. Pork. Lamb. Turkey. Ham

When slicing warm boneless roasts, remove from oven and let set 15-20 minutes before slicing. They will retain more natural juices and slice evenly without crumbling. Cut the roast if necessary, to fit on the feeder. If roast is tied, turn off motor and remove strings one at a time as strings near blade.

Cheese

Chill thoroughly before slicing. Cover with foil to keep moist. Before serving, allow cheese to reach room temperature-this enhances the natural flavor.

Cold cuts

Cold cuts keep longer and retain flavor if sliced as needed. For best results, chill first. Remove any plastic or hard cass before slicing. Use a constant, gently pressure for uniform slicing.

Breads, Cakes an Cookies

Freshly baked bread should be cooled before slicing. Use day old or slightly stale bread for extra thin slices for toasting. Your sheer is ideal for all types of party breads, pound cake and fruit cake.

Care and Cleaning

+ Always place On/Off switch in "OFF" Position and remove sheer cord plug from electrical outlet before cleaning.

+ Never use steel wool or scouring powder on any part of sheer. Wash only removable parts in dishwasher.

+ Motor is concealed in housing. Never submerge in water. Motor never needs oiling.

1. Remove all slicing parts for thorough cleaning. Wash with a soft cloth or sponge and a mild soap. Rinse and dry. ef

2. For easier cleaning, remove feeder by releasing the metal rod (for select models only; as shown on image A).

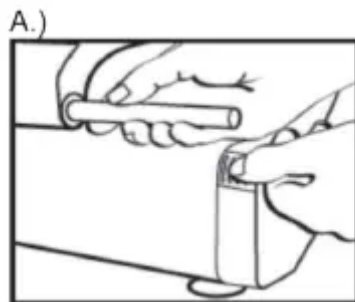

3. Slide to remove Food Pusher.

4. Remove blade carefully (as shown on image B).

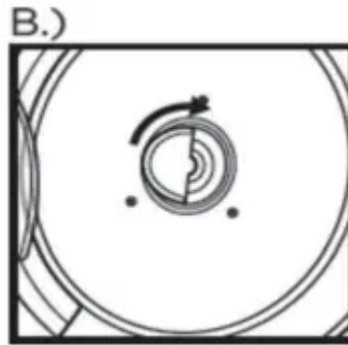

NOTE: Always align thickness guide with blade for safety and blade protection during storage.

Storage

1. Make sure blade is securely locked/tightened.
2. Align thickness guide with blade.

Warning

This content is compiled from multiple sources and is provided for reference purposes only. It may not be complete or fully applicable to all situations. If you are unable to resolve your issue, please contact the product manufacturer or an authorized service provider for official support.