

Assembling the TV

Attaching the TV to the Stand

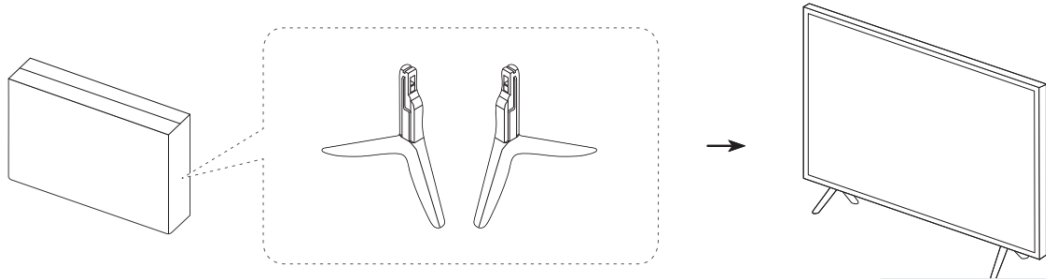

Make sure you have all the accessories shown, and that you assemble the stand following the provided assembly instructions.

- The product colour and shape may vary depending on the model.
- For the assembly method and stand components, refer to Quick Setup Guide.

Mounting the TV on a wall

- You can mount the TV on the wall using a wall mount kit (sold separately).
- Refer to the installation manual included with the Samsung wall mount kit.

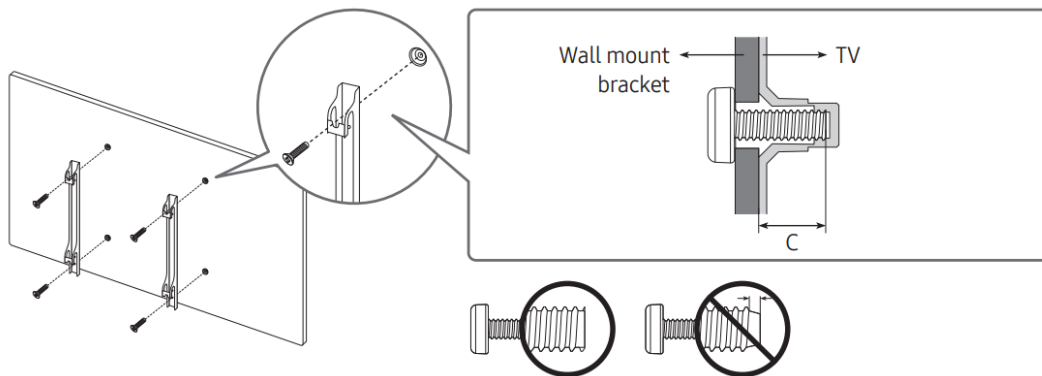

- Samsung Electronics is not responsible for any damage to the product or injury to yourself or others if you choose to install the wall mount on your own.
- You can install your wall mount on a solid wall perpendicular to the floor. Before attaching the wall mount to surfaces other than plaster board, contact your nearest dealer for additional information. If you install the TV on a ceiling or slanted wall, it may fall and result in severe personal injury.
- Standard dimensions for wall mount kits are shown in the table on the next page.

- If you are installing a third-party wall mount, note that the length of the screws you can use to attach the TV to the wall mount is shown in column C in the table on the next page.
- When installing a wall mount kit, we recommend you fasten all four VESA screws.
- If you want to install a wall mount kit that attaches to the wall using two top screws only, be sure to use a Samsung wall mount kit that supports this type of installation. (You may not be able to purchase this type of wall mount kit, depending on the geographical area.)

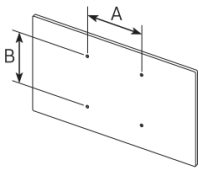
TV size in inches	VESA screw hole specs (A * B) in millimetres	C (mm)	Standard Screw	Quantity	
43-55	200 x 200	20-22 *39-41	M8	4	
65	400 x 300				
75	400 x 400				
82	600 x 400				

*: These specifications are supported by TU8500, TU8507, TU8510.

- Do not use screws that are longer than the standard dimension or do not comply with the VESA standard screw specifications. Screws that are too long may cause damage to the inside of the TV set.
- For wall mounts that do not comply with the VESA standard screw specifications, the length of the screws may differ depending on the wall mount specifications.
- Do not fasten the screws too firmly. This may damage the product or cause the product to fall, leading to personal injury. Samsung is not liable for these kinds of accidents.
- Samsung is not liable for product damage or personal injury when a non-VESA or nonspecified wall mount is used or when the consumer fails to follow the product installation instructions.
- Do not mount the TV at more than a 15 degree tilt.
- Always have two people mount the TV onto a wall. – For 82 inch or larger models, have four people mount the TV onto a wall.

Providing proper ventilation for your TV

When you install your TV, maintain a distance of at least 10 cm between the TV and other objects (walls, cabinet sides, etc.) to ensure proper ventilation. Failing to maintain proper ventilation may result in a fire or a problem with the product caused by an increase in its internal temperature.

- When you install your TV with a stand or a wall mount, we strongly recommend you use parts provided by Samsung Electronics only. Using parts provided by another manufacturer may cause difficulties with the product or result in injury caused by the product falling.

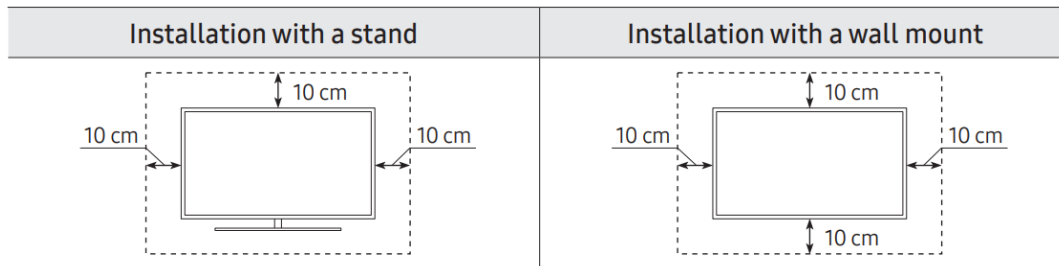

Other Cautions

- The actual appearance of the TV may differ from the images in this manual, depending on the model.
- Be careful when you touch the TV. Some parts can be somewhat hot.

The TV Control Stick

Using the TV Controller

You can turn on the TV with the TV Controller button at the bottom of the TV, and then use the Control menu. The Control menu appears when the TV Controller button is pressed while the TV is On. For more information about its usage, refer to the figure below.

- The screen may dim if the protective film on the SAMSUNG logo or the bottom of the TV is not detached. Please remove the protective film.

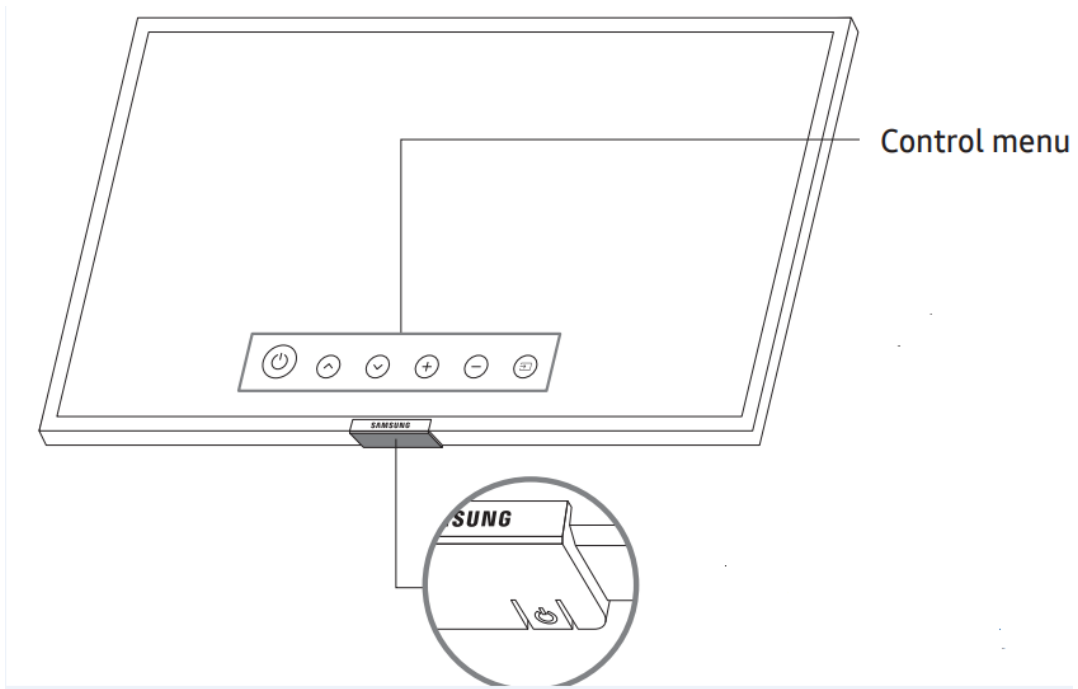

Power off



Channel Up



Channel Down



Volume Up



Volume Down



Source

TV Controller button / Remote control sensor



Press: Move



Press & Hold: Select

The TV Controller button is located on the bottom of the TV.

The Remote Control

About the Buttons on the Remote Control

- This remote control has Braille points on the Power, Channel, Volume, and Select buttons and can be used by visually impaired persons.
- The images, buttons, and functions of the remote control may differ depending on the model.
- If you use the remote control that comes with your TV to control another TV, some functions may not operate normally

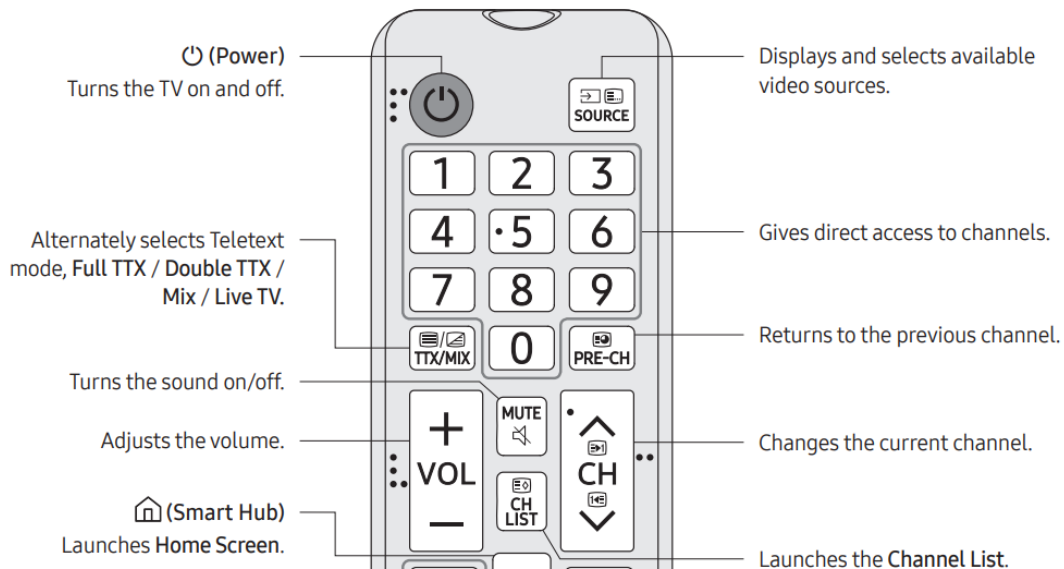

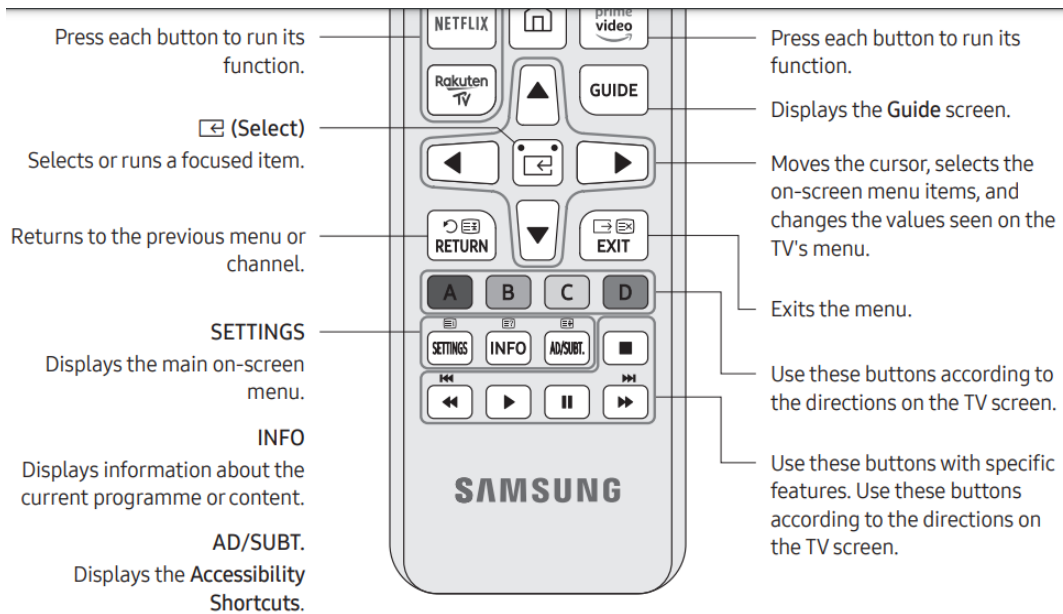

Installing batteries into the remote control (Battery size: AAA)

Match the polarities of the batteries to the symbols on the battery compartment.

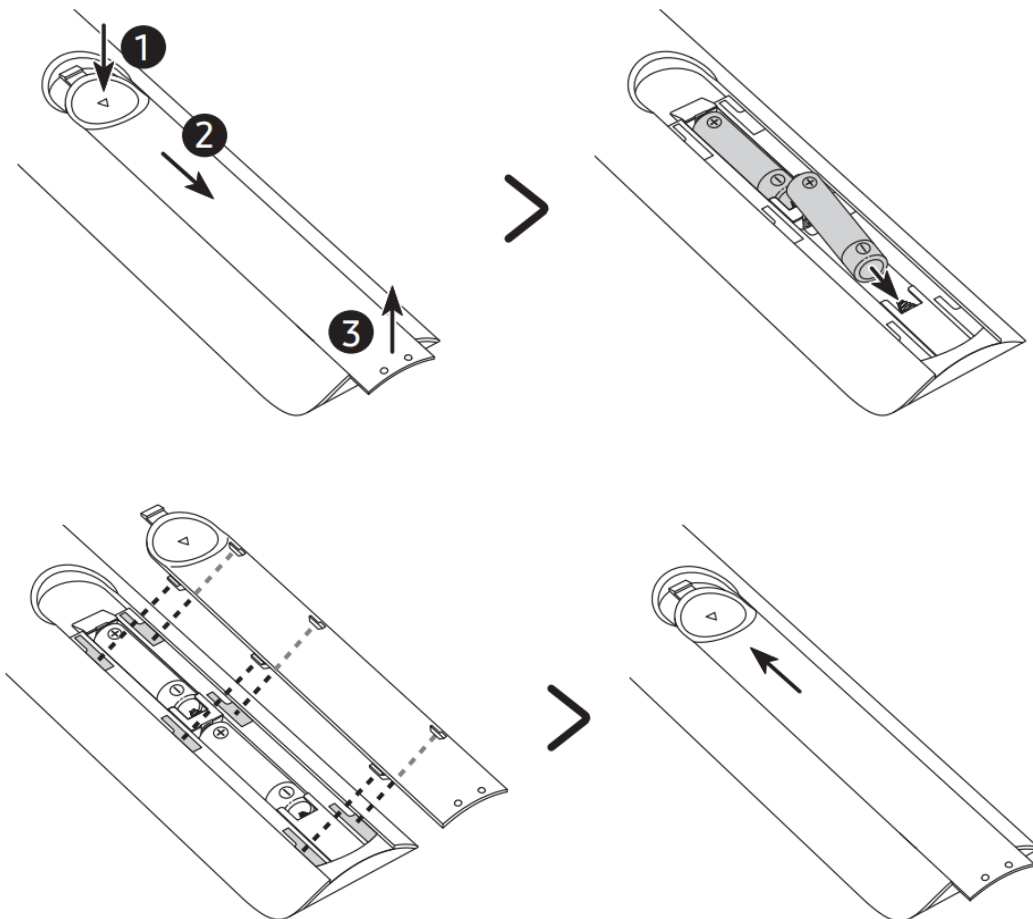

- The colour and shape of the remote may vary depending on the model.
- Use the remote control within 7 m of the TV.

- Bright lights may affect the performance of the remote control. Avoid using the remote control near special fluorescent lights or neon signs.

- Alkaline batteries are recommended for longer battery life.

1. Gently pull on the battery cover's notch and then remove the cover completely once it comes loose.

2. Insert 2 AAA alkaline batteries, making sure to align the positive and negative polarities correctly.

3. Place the battery cover on the remote control and insert the cover into the remote control.

4. Slide the battery cover in the order shown above so that the cover is completely attached to the remote control.

The Samsung Smart Remote

About the Buttons on the Samsung Smart Remote

- The images, buttons, and functions of the Samsung Smart Remote may differ depending on the model.

- The Universal Remote function operates normally only when you use the Samsung Smart Remote that comes with the TV.

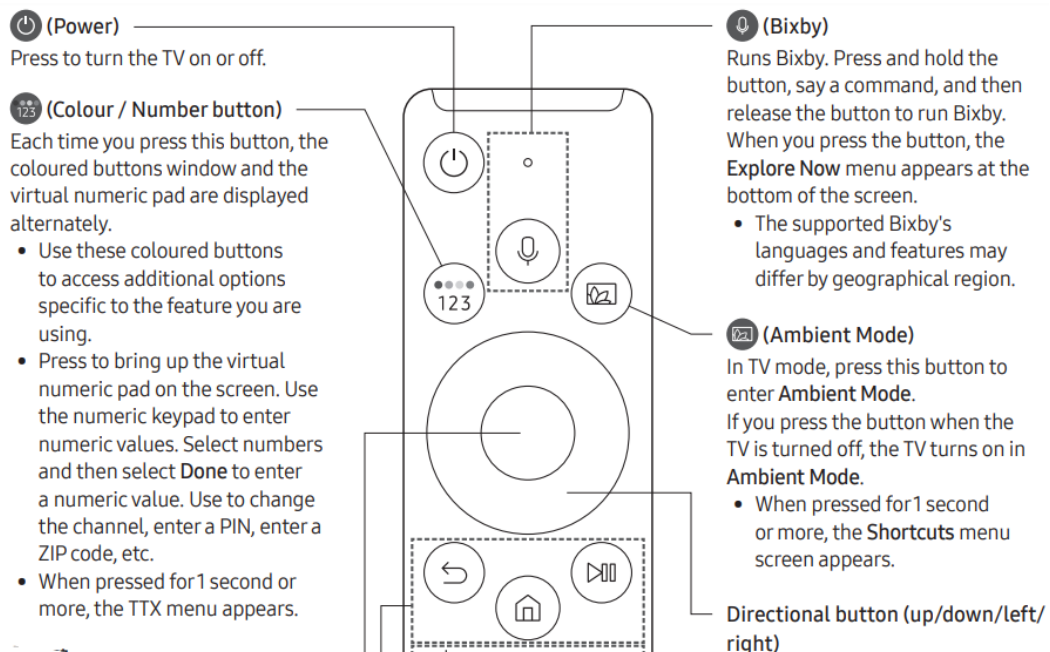

Select
Selects or runs a focused item. When pressed while you are watching a broadcast programme, detailed programme information appears.

(Return)
Returns to the previous menu. When pressed for 1 second or more, the running function is terminated. When pressed while you are watching a programme, the previous channel appears.

(Play/pause)
When pressed, the playback controls appear while the media content is playing.

(Smart Hub)
Returns to the Home Screen.

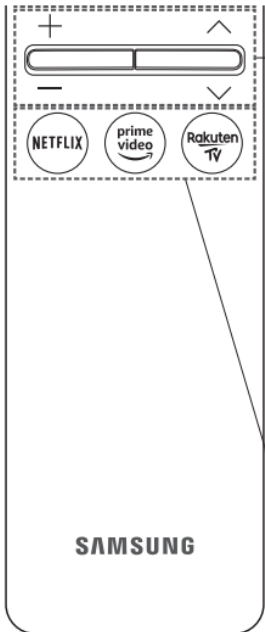

Moves the focus and changes the values seen on the TV's menu.

+ / - (Volume)
Move the button up or down to adjust the volume. To mute the sound, press the button. When pressed for 1 second or more, the **Accessibility Shortcuts** menu appears.

^ / v (Channel)
Move the button up or down to change the channel. To see the **Guide** screen, press the button.

- When pressed for 1 second or more, the **Channel List** screen appears.

Press each button to run its function.

Installing batteries into the Samsung Smart Remote

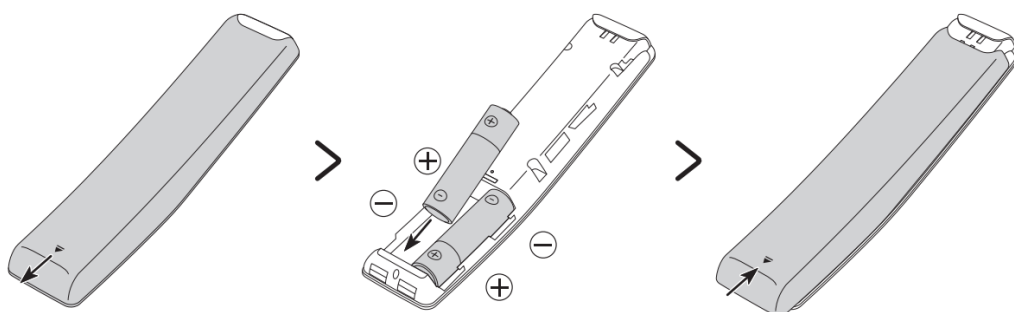

To install the batteries, push the rear cover open in the direction of the arrow at the bottom of the illustration, and then insert the batteries as shown in the figure. Make sure that the positive and negative ends are facing in the correct direction. Close the rear cover as shown.

- Alkaline batteries are recommended for longer battery life.

About the Samsung Smart Remote

When you start the TV for the first time by pressing the  (Power) button on the Samsung Smart Remote, the TV automatically pairs with the Samsung Smart Remote. Once the TV and Samsung Smart Remote have paired, you can use the Samsung Smart Remote to operate the TV. We recommend using Samsung Smart Remote at a distance of less than 6 m. A usable distance may differ depending on the wireless environmental conditions.

Pairing the TV to the Samsung Smart Remote

When you turn on the TV for the first time, the Samsung Smart Remote pairs to the TV automatically. If the Samsung Smart Remote does not pair to the TV automatically,

point it at the remote control sensor of the TV, and then press and hold the



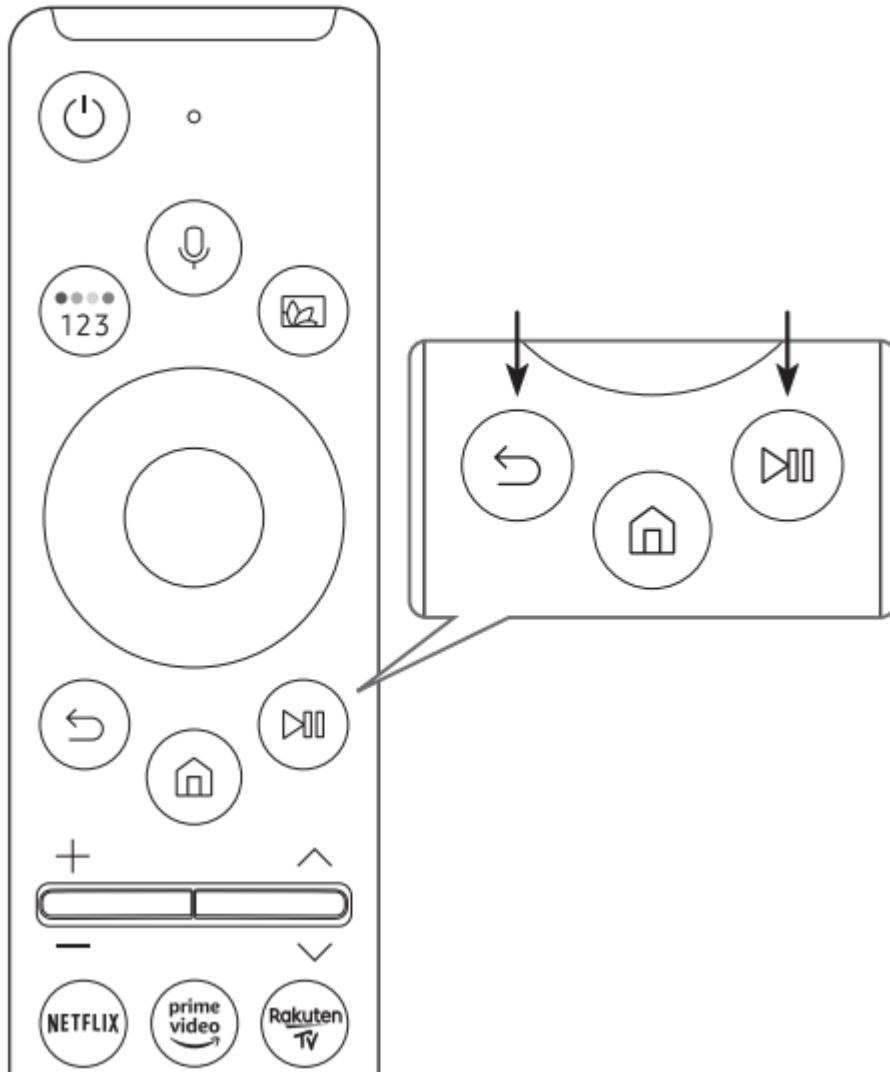

and  buttons simultaneously for 3 seconds or more.

- The Samsung Smart Remote can only be paired to one TV at a time.



Controlling External Devices with a Samsung Remote Control - Using the Universal Remote

 >  Source > Universal Remote



You can control external devices connected to the TV using a Samsung remote control. To control external devices, register them by following the instructions on the screen.

- This function may not be supported depending on the model.
- You can also use the Anynet+ (HDMI-CEC) function to operate external Samsung devices with your TV's remote control without any additional setup.
- Certain external devices connected to the TV may not support the universal remote feature.
- Do not place any obstacles in front of an external device and TV's logo. It may cause signals from the remote control to be transmitted improperly.
- The TV memorises both the external device and its connection port (HDMI 1, HDMI 2, etc.).
- If you have difficulty controlling external devices with the Universal Remote, try adjusting the positions of the external devices.
- This function may not operate properly depending on the TV installation environment and the features of external devices.

Performing the initial setup

- The initial setup differs from model to model.
- Turn on the TV using the P button on the remote control or TV controller.
- Noise may occur temporarily when the TV communicates with mobile devices.
- The SmartThings app is available for mobile devices running Android 6.0 or higher or iOS 10 or higher.
- To perform Initial Setup using the SmartThings app, you must connect your mobile device via Wi-Fi.
- If the pop-up for setup does not appear automatically on the SmartThings app on your mobile device, continue setup manually after adding the TV using Add Device on the dashboard of the SmartThings app.

You can also start the Initial Setup using the TV's menu

 >  **Settings** > **General** > **Reset**. Follow the instructions displayed on the Initial Setup screen and configure the TV's basic settings to suit your viewing environment.

Initial setup

When you turn on your TV for the first time, it immediately starts the Initial Setup. The Initial Setup allows you to configure the basic settings for the TV to operate, such as broadcast reception, channel search, and network connection, at one time.

- Before starting the Initial Setup, be sure to connect external devices first.
- To use the TV's smart features, the TV must be connected to the Internet.

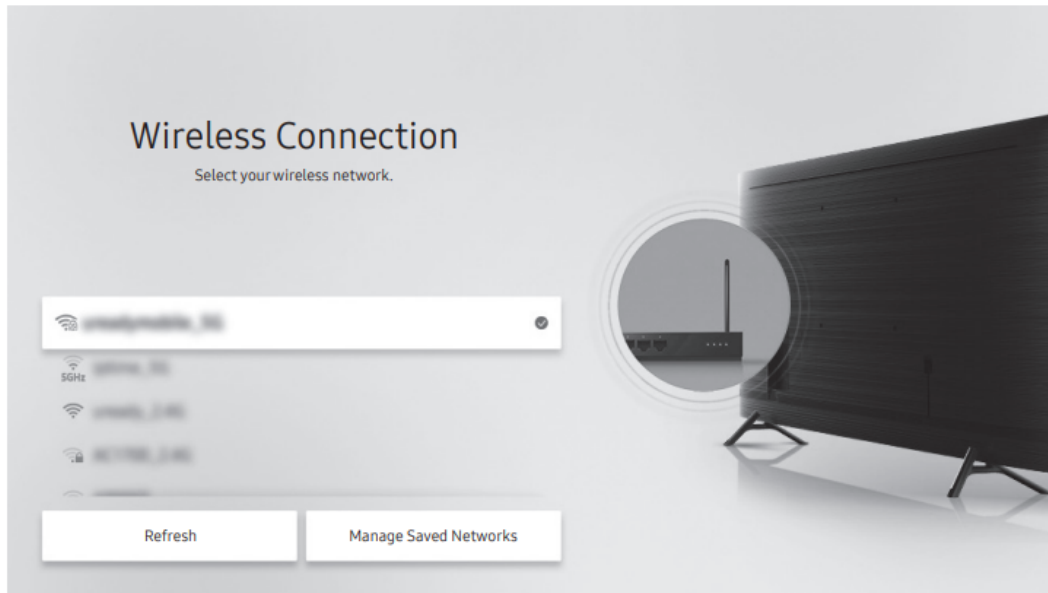







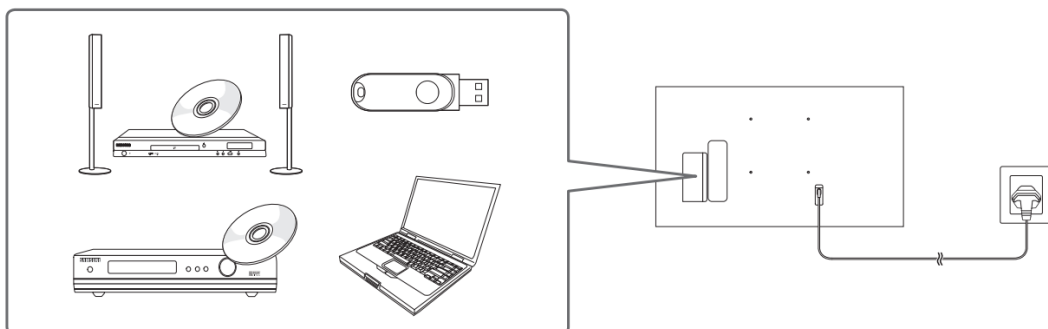

- The image on your TV may differ from the image above depending on the model and geographical area.
- If you connect any external device to HDMI IN (STB) before starting initial setup, the source of your live TV signal is set to STB. After finishing with this process, you will not be able to scan all channels and stores them in the TV's memory.
- If you want to connect aerial cable to your TV, select Aerial. In this case, you will be able to scan all channels and stores them in the TV's memory

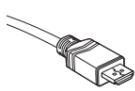
Connections

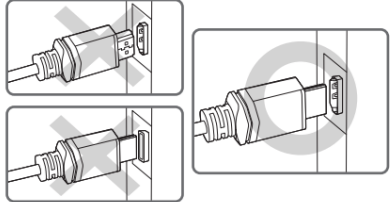
Connecting devices to your TV

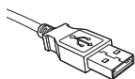

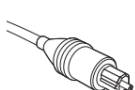
You can connect various external devices using the connectors located at the back of the product. Check the connectors and then refer to the Quick Guide for more instructions on supported external devices. For more information about connections, see the e-Manual chapter "Guide > Connections". Make sure you have the correct cable before plugging it in. Illustrations of common plugs and ports are shown below.

	Cable Plugs	Ports	
HDMI			 <p> Do not plug cables in upside down. Be sure to check the orientation of the plug before plugging it in.</p>
USB			
Optical			

Connecting to the Internet

Connecting the TV to a network gives you access to online services such as the Smart Hub, as well as software updates.

- For more information about Smart Hub, see the e-Manual chapter, "Guide > Smart Features > Using Smart Hub".
- The shape of the rear panel differs among the models.

Network Connection - Wireless

Connect the TV to the Internet using a wireless access point or modem.

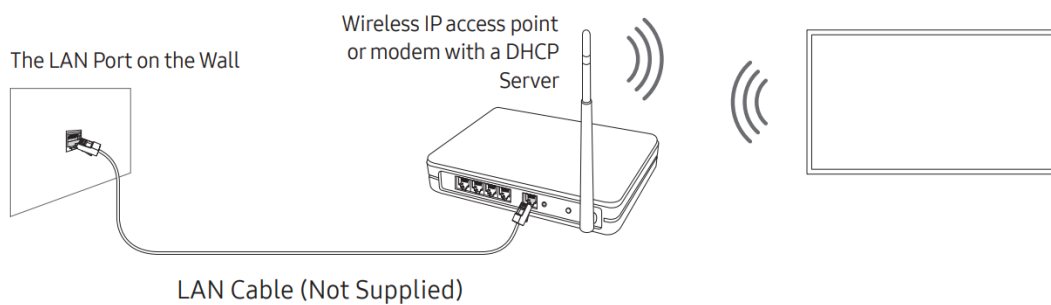

Network Connection - Wired

There are three main ways to connect your TV to your network using cable, depending on your network setup. They are illustrated starting below:

The LAN Port on the Wall

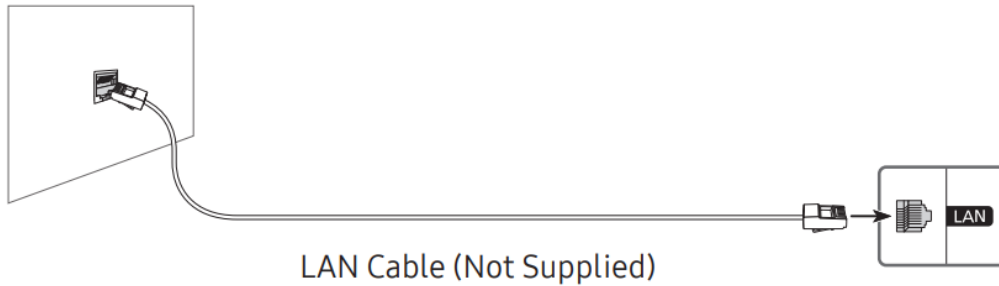

- The TV will not be able to connect to the Internet if your network speed is below 10 Mbps.
- Use Cat7 (*STP Type) cable for the connection.
- * Shielded Twisted Pair

Selecting Connected Devices

Changing the input signal

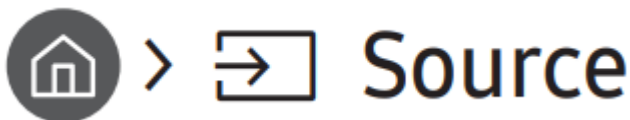

When you select a connected external device on the Source screen, the output of the selected device is displayed on the TV's screen.

- For more information about selecting connected devices, see the e-Manual chapter "Guide > Connections > Switching between external devices connected to the TV".

Editing external devices

You can change the port name for a connected external device or add it to Home Screen.

1. Move the focus to a connected external device.
2. Press the Up directional button. The following functions become available.
 - Available functions may differ depending on the port type.
 - Universal Remote: You can control external devices connected to the TV using a Samsung remote control. To control external devices, register them by following the instructions on the screen.
 - Edit: You can rename the input ports and change the device icons.

- **Information:** You can view the detailed information about the external devices connected to the TV.
- **Add to Home:** You can add the port of an external device to the Home Screen for quick switching.



Using additional functions





You can use the following features on the Source screen.

- **Remote Access:** Use the TV to access your PC via remote PC or Screen Sharing (Wireless).
- **Connection Guide:** The guide to device connections
- **Universal Remote:** Lets you register external devices to your Samsung remote control and control them using the Remote.

Troubleshooting



<p>The TV won't turn on.</p>	<ul style="list-style-type: none"> • Make sure that the AC power cord is securely plugged in to the TV and the wall outlet. • Make sure that the wall outlet is working and the remote control sensor at the bottom of the TV is lit and glowing a solid red. • Try pressing the TV Controller button at the bottom of the TV to make sure that the problem is not with the remote control. If the TV turns on, refer to “The remote control does not work”.
<p>There is no picture/video/sound, or a distorted picture/video/sound from an external device, or “Weak or No Signal” is displayed on the TV, or you cannot find a channel.</p>	<ul style="list-style-type: none"> • Make sure the connection to the device is correct and that all cables are fully inserted. • Remove and reconnect all cables connected to the TV and the external devices. Try new cables if possible. • Confirm that the correct input source has been selected  . • Perform a TV self diagnosis to determine if the problem is caused by the TV or the device  . • If the test results are normal, reboot the connected devices by unplugging each device's power cord and then plugging it in again. If the issue persists, refer to the connection guide in the user manual of the connected device. • If you are not using a cable box or satellite box, and your TV is receiving TV signals from an antenna or a cable wall connector, run Auto Tuning to search for channels  Settings > Broadcasting > (Auto Tuning Settings) > Auto Tuning). <ul style="list-style-type: none"> – The Auto Tuning Settings may not appear depending on the model or geographical area.

	<p>– If you are using a cable box or satellite box, please refer to the cable box or satellite box manual.</p>
The CI+ does not work.	<ul style="list-style-type: none"> • Your Samsung TV conforms to the CI+ 1.4 standards. • Where a CI+ Common Interface module is incompatible with this device, then please remove the module and contact the CI+ operator for assistance.
The remote control does not work.	<ul style="list-style-type: none"> • Check if the power indicator at the bottom of the TV blinks when you press the remote's Power button. If it does not, replace the remote control's batteries. • Make sure that the batteries are installed with their poles (+/-) in the correct direction. • Try pointing the remote directly at the TV from 1.5-1.8 m away. • If your TV came with a Samsung Smart Remote (Bluetooth Remote), make sure to pair the remote to the TV.
The cable box or satellite box remote control doesn't turn the TV on or off or adjust the volume.	<ul style="list-style-type: none"> • Programme the cable box or satellite box remote control to operate the TV. Refer to the cable box or satellite box user manual for the SAMSUNG TV code.
The TV settings are lost after 5 minutes.	<p>he TV is in the Retail Mode. Change the Usage Mode in the General Menu to Home Mode</p> <p> >  Settings > General > System Manager > Usage Mode > Home Mode).</p>
Intermittent Wi-Fi	<ul style="list-style-type: none"> • Make sure the TV has a network connection <p> >  Settings > General > Network > Network Status).</p> <ul style="list-style-type: none"> • Make sure the Wi-Fi password is entered correctly.

- Check the distance between the TV and the modem or access point. The distance should not exceed 15.2 m.
- Reduce interference by not using or turning off wireless devices. Also, verify that there are no obstacles between the TV and the modem or access point. (The Wi-Fi strength can be decreased by appliances, cordless phones, stone walls/fireplaces, etc.)

Single story

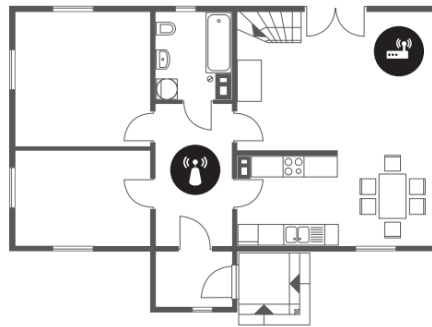

Multi story







Wireless access point



Wireless repeater

- Contact your Internet Service Provider (ISP) and ask them to reset your network circuit to re-register the MAC addresses of your modem or access point and the TV.

<p>Video Apps problems (Youtube etc)</p>	<ul style="list-style-type: none"> • Change the DNS to 8.8.8.8. Select  >  Settings > General > Network > Network Status > IP Settings > DNS setting > Enter manually > DNS Server > enter 8.8.8.8 > OK. • Reset by selecting  >  Settings > Support > Device Care > Self Diagnosis > Reset Smart Hub.
--	--



What is Remote Support?

Samsung Remote Support service offers you one-on-one support with a Samsung Technician who can remotely:

- Diagnose your TV
- Adjust the TV settings for you
- Perform a factory reset on your TV
- Install recommended firmware updates

How does Remote Support work?

You can easily get Samsung Remote Support service for your TV:

1. Call the Samsung service centre and ask for remote support.
2. Open the menu on your TV and go to the Support menu. ( >  **Settings** > Support)
3. Select Remote Management, then read and agree to the service agreements. When the PIN screen appears, provide the PIN number to the technician.
4. The technician will then access your TV.

Maintenance

- If a sticker was attached to the TV screen, some debris can remain after you remove the sticker. Please clean the debris off before watching TV.
- The exterior and screen of the TV can get scratched during cleaning. Be sure to wipe the exterior and screen carefully using a soft cloth to prevent scratches.
- Do not spray water or any liquid directly onto the TV. Any liquid that goes into the product may cause a failure, fire, or electric shock.

- To clean the screen, turn off the TV, then gently wipe away smudges and fingerprints on the panel with a micro-fiber cloth. Clean the body or panel of the TV with a micro-fiber cloth dampened with a small amount of water. After that, remove the moisture with a dry cloth. While cleaning, do not apply strong force to the surface of the panel because it can damage the panel. Never use flammable liquids (benzene, thinner, etc.) or a cleaning agent. For stubborn smudges, spray a small amount of screen cleaner on a micro-fiber cloth, and then use the cloth to wipe away the smudges.

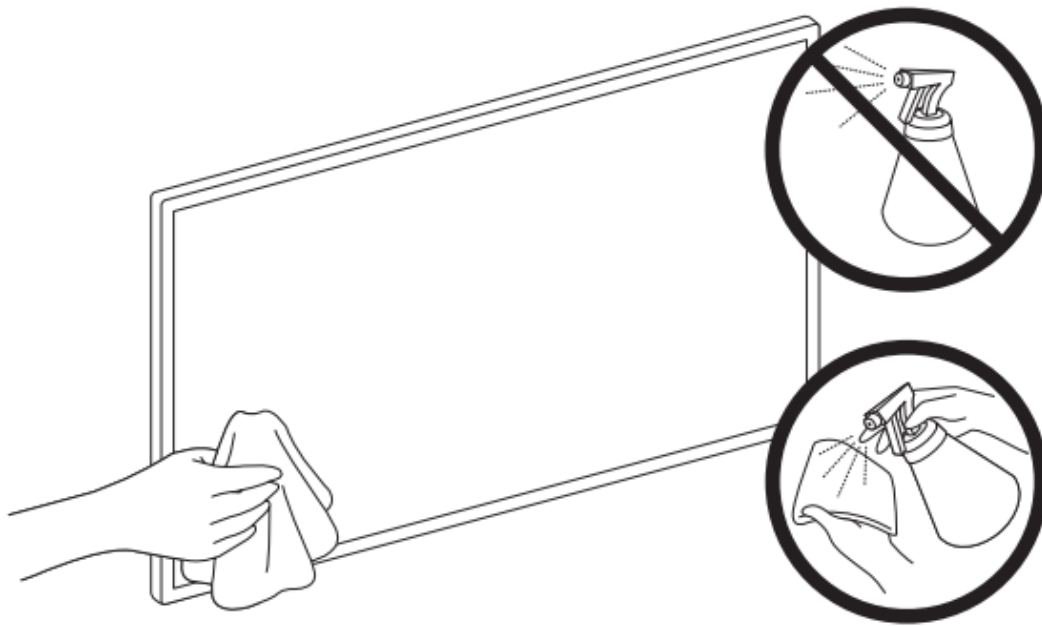

Specifications

Model Name	UE55TU8000	UE65TU8000
Display Resolution	3840 x 2160	3840 x 2160
Screen Size	55 inches	65 inches
Measured Diagonally	138 cm	163 cm
Sound (Output)	20 W	20 W
Dimensions (W x H x D)		
Body	1230.5 x 707.2 x 59.9 mm	1449.4 x 830.3 x 59.9 mm
With Stand	1230.5 x 783.3 x 250.2 mm	1449.4 x 906.6 x 282.1 mm
Weight		
Without Stand	13.9 kg	20.6 kg
With Stand	14.2 kg	20.9 kg

Model Name	UE55TU8000	UE65TU8000
Display Resolution	3840 x 2160	3840 x 2160
Screen Size	55 inches	65 inches
Measured Diagonally	138 cm	163 cm
Sound (Output)	20 W	20 W
Dimensions (W x H x D)		
Body	1230.5 x 707.2 x 59.9 mm	1449.4 x 830.3 x 59.9 mm
With Stand	1230.5 x 783.3 x 250.2 mm	1449.4 x 906.6 x 282.1 mm
Weight		
Without Stand	13.9 kg	20.6 kg
With Stand	14.2 kg	20.9 kg

Model Name	UE75TU8000	UE82TU8000
Display Resolution	3840 x 2160	3840 x 2160
Screen Size Measured Diagonally	75 inches 189 cm	82 inches 207 cm
Sound (Output)	20 W	20 W
Dimensions (W x H x D)		
Body	1673.2 x 958.2 x 59.9 mm	1829.9 x 1045.0 x 59.9 mm
With Stand	1673.2 x 1047.9 x 341.1 mm	1829.9 x 1148.2 x 392.2 mm
Weight		
Without Stand	30.4 kg	37.7 kg
With Stand	30.8 kg	38.9 kg

Model Name	UE43TU8500 / UE43TU8507 / UE43TU8510	UE50TU8500 / UE50TU8507 / UE50TU8510
Display Resolution	3840 x 2160	3840 x 2160
Screen Size Measured Diagonally	43 inches 108 cm	50 inches 125 cm
Sound (Output)	20 W	20 W
Dimensions (W x H x D)		
Body	963.5 x 557.7 x 56.8 mm	1116.4 x 642.9 x 57.1 mm
With Stand	963.5 x 645.2 x 334.3 mm	1116.4 x 728.1 x 326.5 mm
Weight		
Without Stand	9.0 kg	12.9 kg
With Stand	11.3 kg	15.2 kg

Model Name	UE55TU8500 / UE55TU8507	UE65TU8500 / UE65TU8507
Display Resolution	3840 x 2160	3840 x 2160
Screen Size Measured Diagonally	55 inches 138 cm	65 inches 163 cm
Sound (Output)	20 W	20 W
Dimensions (W x H x D)		
Body	1230.1 x 705.9 x 57.4 mm	1449.6 x 829.3 x 57.6 mm
With Stand	1230.1 x 793.0 x 340.4 mm	1449.6 x 918.5 x 371.4 mm
Weight		
Without Stand	17.2 kg	22.3 kg
With Stand	18.8 kg	24.9 kg

Warning

This content is compiled from multiple sources and is provided for reference purposes only. It may not be complete or fully applicable to all situations. If you are unable to resolve your issue, please contact the product manufacturer or an authorized service provider for official support.