

Operating Instructions

About the controls with temperature settings.

Not all features are on all models. Your controls will look like one of the following:

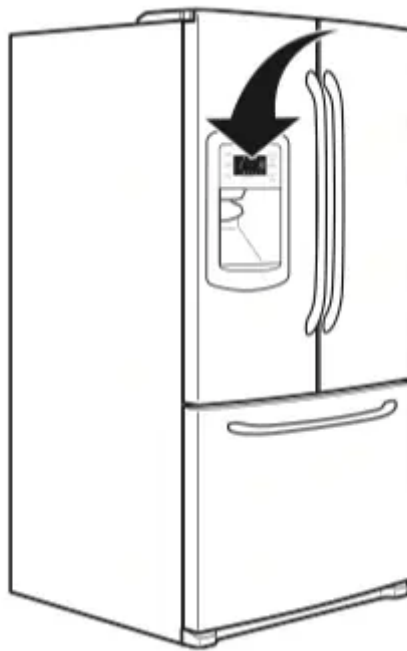

Location of Dispenser Controls

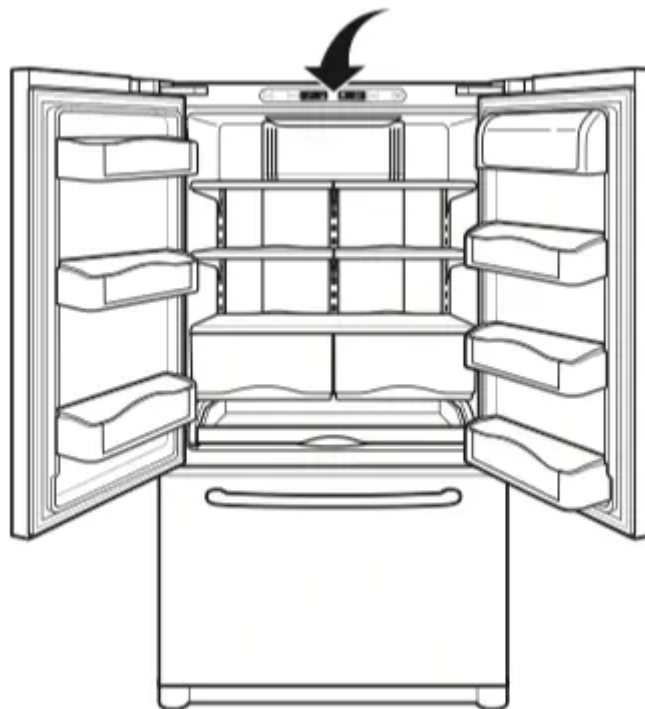

Location of Internal Controls

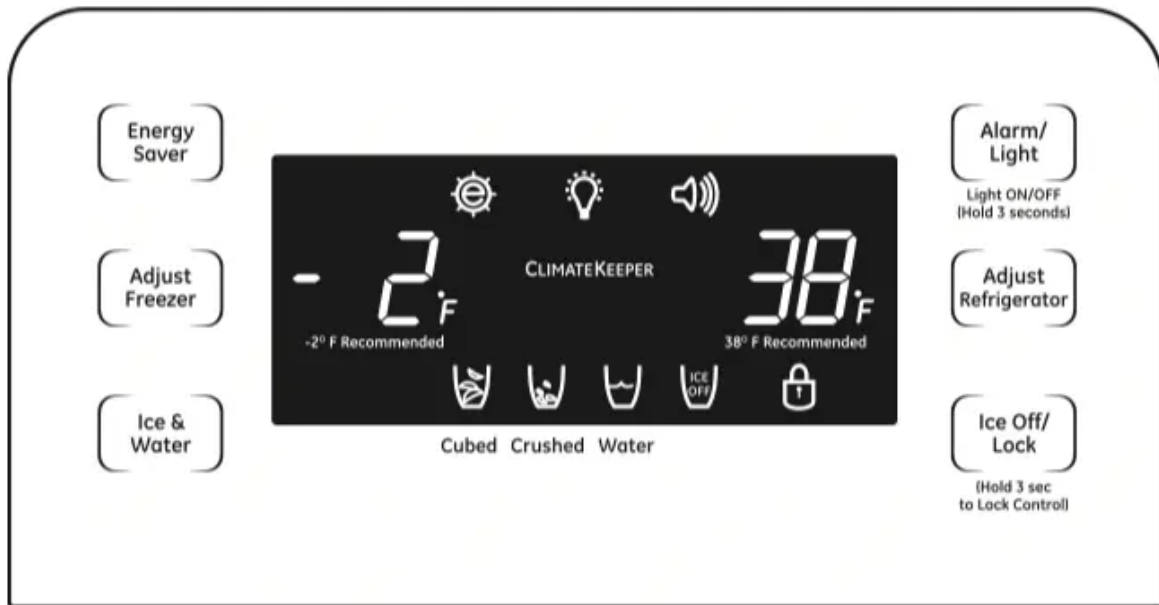

Dispenser Models



Internal Control Models

NOTE: The refrigerator is shipped with protective film covering the temperature controls. If this film was not removed during installation, remove it now.

The temperature controls are preset in the factory at 38°F for the refrigerator compartment and -2°F for the freezer compartment. Allow 24 hours for the temperature to stabilize to the preset recommended settings.

The temperature controls can display both the SET temperature as well as the actual temperature in the refrigerator and freezer. The actual temperature may vary slightly from the SET temperature based on usage and operating environment.

Changing the Temperature



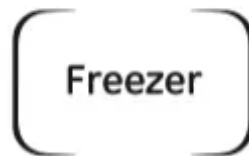

Dispenser models:

To change the temperature, press and release the Adjust Freezer or Adjust Refrigerator pad.

The display will show the actual temperature.

Tap either the Adjust Freezer or Adjust Refrigerator pad until the desired temperature is displayed.

Once the desired temperature has been set, the temperature display will return to the actual refrigerator and freezer temperatures after 10 seconds. Several adjustments may be required.

Each time you adjust controls, allow 24 hours for the refrigerator to reach the temperature you have set.

Internal control models:

To change the temperature, press and release the Freezer or Fridge pad. The display will show the actual temperature. Tap either the Freezer or Fridge pad until the desired temperature is displayed.



Once the desired temperature has been set, the temperature display will return to the actual refrigerator and freezer temperatures after 10 seconds. Several adjustments may be required.

Each time you adjust controls, allow 24 hours for the refrigerator to reach the temperature you have set.

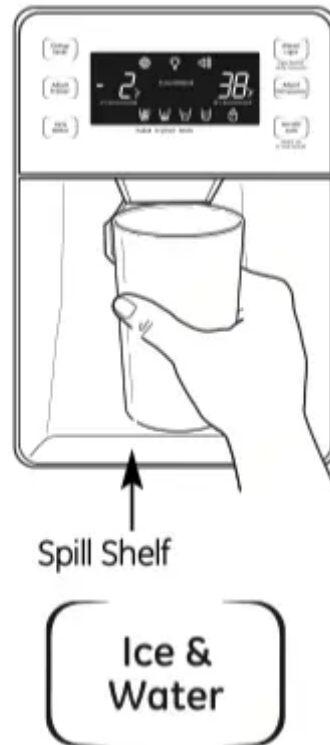
About the controls.



To Use the Dispenser (on some models)

Select Cubed Ice , Crushed Ice  or Water  by pressing the Ice & Water pad.

Press the glass gently against the top of the dispenser cradle.

The spill shelf is not self-draining.

To reduce water spotting, the shelf should be cleaned regularly.

If no water is dispensed when the refrigerator is first installed, there may be air in the water line system. Press the dispenser arm for at least two minutes to remove trapped air from the water line and to fill the water system. To flush out impurities in the water line, throw away the first six full glasses of water.

CAUTION:

Never put fingers or any other objects into the ice crusher discharge opening.

To Lock and Unlock the Dispenser (on some models)



To lock, press and hold the Ice Off/Lock pad for 3 seconds. Repeat this step to unlock the dispenser.

Internal Water Dispenser (on some models)

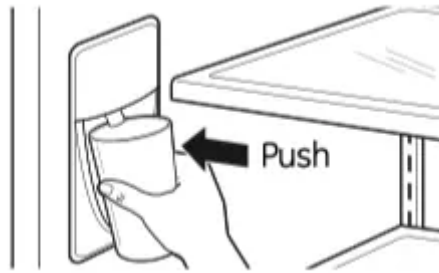

To use the internal water dispenser, place a glass underneath the water outlet and push gently against the dispenser with your glass.

Important Facts About Your Dispenser

- Do not add ice from trays or bags to the storage drawer. It may not crush or dispense well.
- Avoid overfilling glass with ice and use of narrow glasses. Backed-up ice can jam the chute or cause the door in the chute to freeze shut. If ice is blocking the chute, poke it through with a wooden spoon.
- Beverages and foods should not be quick-chilled in the ice storage drawer. Cans, bottles or food packages in the storage drawer may cause the icemaker or auger to jam.
- To keep dispensed ice from missing the glass, put the glass close to, but not touching, the dispenser opening.
- Some crushed ice may be dispensed even though you selected Cubed Ice. This happens occasionally when a few cubes accidentally get directed to the crusher.
- After crushed ice is dispensed, some water may drip from the chute.
- Sometimes a small mound of snow will form on the door in the ice chute. This condition is normal and usually occurs when you have dispensed crushed ice repeatedly. The snow will eventually evaporate.

About Door Alarm (on some models)



The door alarm will sound if any door is open for more than 3 minutes.

The beeping stops when you close the door.

About Dispenser Light (on some models)

Press and hold the Alarm/Light pad for 3 seconds to turn on the dispenser light. To turn off, press and hold the pad again for 3 seconds.

About Energy Saver



This product is equipped with an Energy Saver feature. The refrigerator is shipped with the Energy Saver feature on.

Over time, moisture can form on the front surface of the refrigerator cabinet and cause rust. If moisture does appear on the front surface of the refrigerator cabinet, turn off the Energy Saver feature by pressing and releasing the Energy Saver pad on the control panel.

About the water filter.

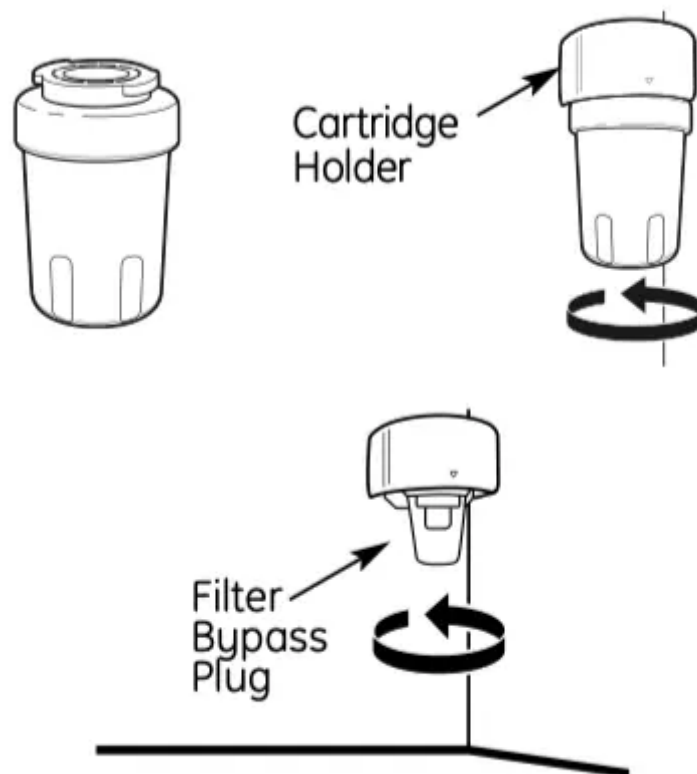

Water Filter Cartridge

The water filter cartridge is located in the back upper right corner of the refrigerator compartment.

When to Replace the Filter



The filter cartridge should be replaced every six months or if the flow of water to the dispenser or icemaker decreases.

Installing the Filter Cartridge

1. If you are replacing the cartridge, first remove the old one by slowly turning it counterclockwise. A small amount of water may drip down.

CAUTION:

If air has been trapped in the system, the filter cartridge may be ejected as it is removed. Use caution when removing.

2. Remove the protective foil from the end of the cartridge.
3. Lining up the arrow on the cartridge and the cartridge holder, place the top of the new cartridge up inside the holder. Do not push it up into the holder. Slowly rotate the cartridge clockwise until it stops. As you turn the cartridge, it will automatically raise itself into position. Cartridge will rotate about 1/4 turn. Do not overtighten.
4. Press and hold the Ice & Water pad for 3 seconds to reset the filter.
5. Run water from the dispenser for 3 minutes (about 1 1/2 gallons) to clear the system and prevent sputtering. See To Use the Dispenser section.

NOTE: A newly installed water filter cartridge may cause water to spurt from the dispenser.



Filter Bypass Plug

You must use the filter bypass plug when a replacement filter cartridge is not available. The icemaker will not operate without the filter or filter bypass plug.

Replacement Filters:

To order additional filter cartridges in the United States, visit our Website, GEAppliances or call GE Parts and Accessories, 800.626.2002.

Filter Model MWF

Customers in Canada should consult the yellow pages for the nearest Mabe Service Center.

About fresh food storage options.

Rearranging the Shelves

Shelves in the refrigerator compartment are adjustable.

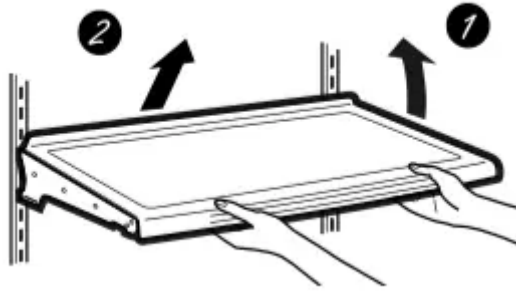

To remove:

1. Remove all items from the shelf.
2. Tilt the shelf up at the front.
3. Lift the shelf up at the back and bring the shelf out.

To replace:

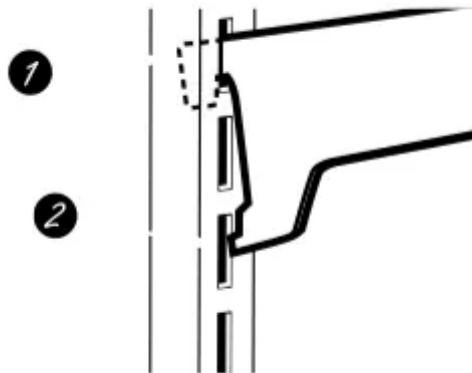

1. While tilting the shelf up, insert the top hook at the back of the shelf in a slot on the track.
2. Lower the front of the shelf until the bottom of the shelf locks into place.

Spillproof Shelves

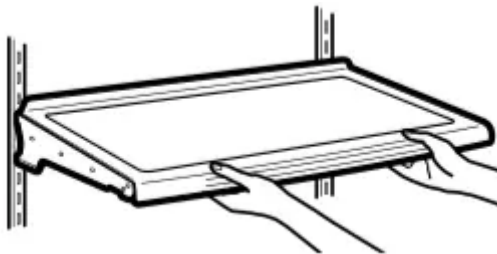

Spillproof shelves have special edges to help prevent spills from dripping to lower shelves.

Floating snack pan (on some models)



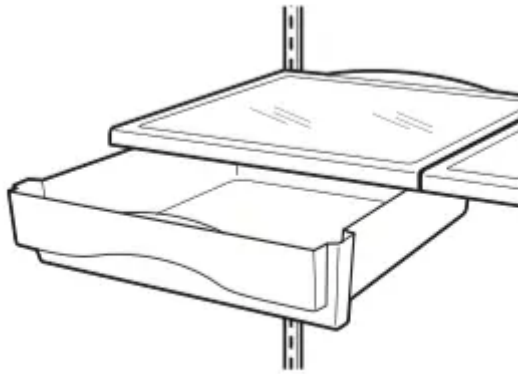

The location of the snack pan is adjustable and can be changed like the other shelves.

To remove:

1. Pull the snack pan out to the stop position.
2. Lift the pan up and past the stop.

Non-Adjustable Dairy Bin

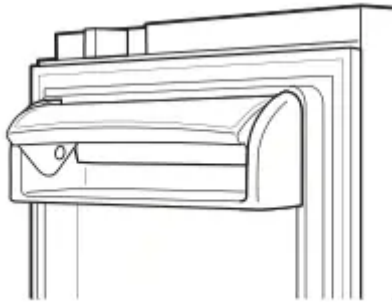

To remove: Lift the dairy bin straight up, then pull out.

To replace: Engage the bin in the molded door supports and push down. The bin will lock in place.

Adjustable Bins on the Door

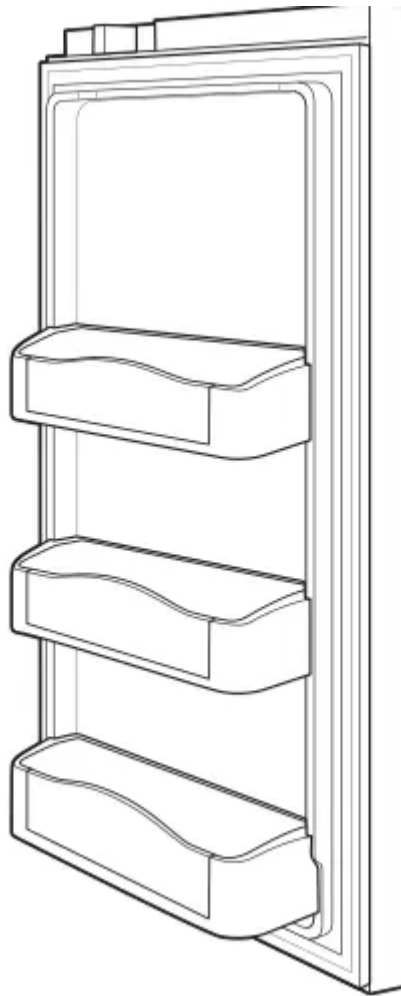

Adjustable bins can easily be carried from refrigerator to work area.

To remove: Lift bin straight up, then pull out.

To replace or relocate: Slide in the bin just above the molded door supports, and push down. The bin will lock in place.

NOTE: On models without a full-width pantry, the location of the bottom door bin is not adjustable.

Non-Adjustable Bins on the Door (on some models)

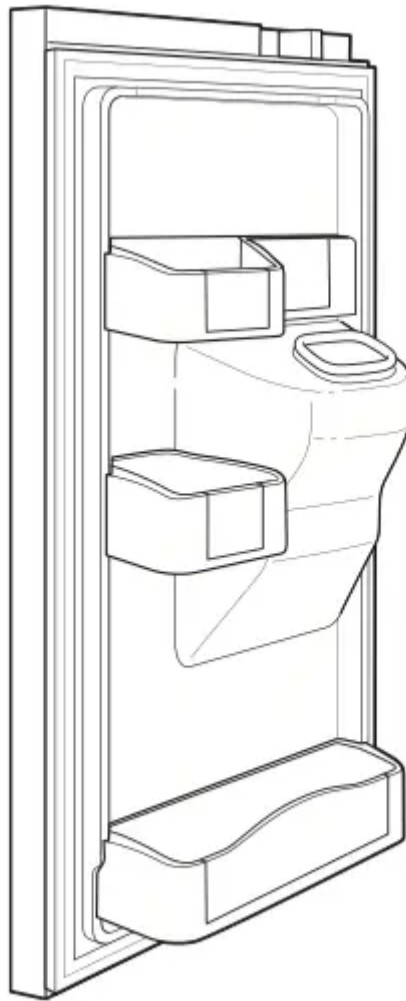

To remove: Lift the bin straight up, then pull out

To replace: Engage the bin in the molded supports on the door and push down. It will lock in place.

Fruit and Vegetable Crisper

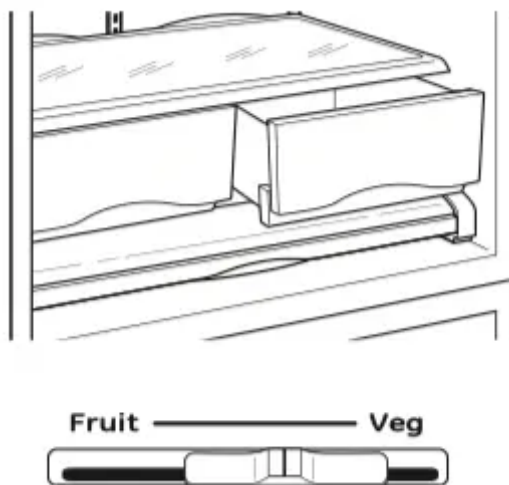

Keep fruits and vegetables organized in separate compartments for easy access.

Excess water that may accumulate in the bottom of the drawers or under the drawers should be wiped dry.

Adjustable Deli/Produce Drawer (on some models)

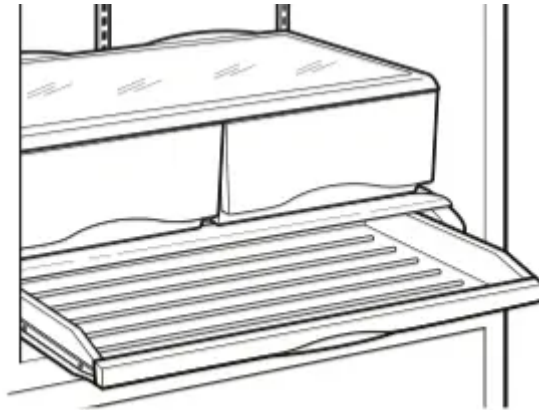

The Adjustable Deli/Produce Drawer is a full-width drawer with adjustable temperature control. This drawer can be used for large miscellaneous items.

There is a temperature control which can adjust the amount of cold air allowed into the drawer.

Control

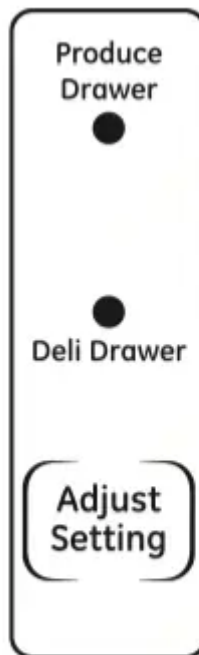

The control is located on the right side of the drawer.

When Produce Drawer is selected, the temperature of the drawer can be kept around 38°F (3.2°C).

When Deli Drawer is selected, the temperature of the drawer can be kept around 34°F (1°C).

NOTE: Fruits and vegetables may be damaged using the Deli Drawer setting. Do not store lettuce or other leafy produce in this drawer.

CAUTION:

Do not store glass bottles in this drawer. If they are frozen, they can break and cause personal injury.

How to Remove and Replace the Adjustable Deli/Produce Drawer

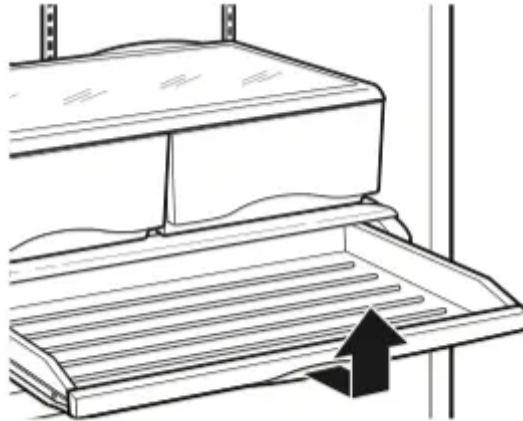

To remove:

1. Pull the drawer out to the stop position.
2. Lift the front of the drawer up and out.

To replace:

1. Lift the cover up.
2. Engage the pantry rollers into the side rails.
3. Push the drawer inward (until it is in place).

How to Remove and Replace Drawer Divider

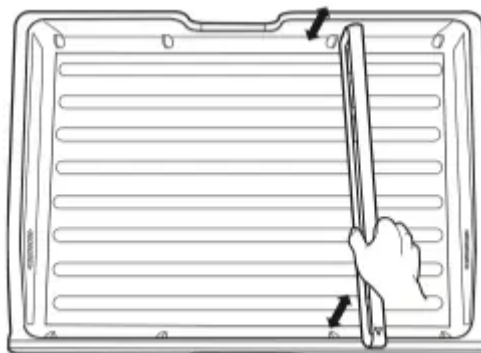

To remove:

1. Pull the drawer out to the stop position.



2. Raise the front side of the divider to unhook it from the rear wall of the drawer.

To replace:

1. Hook the back of the divider over the rear wall of the drawer.
2. Push the divider down.

About the freezer.

Freezer Basket and Drawer

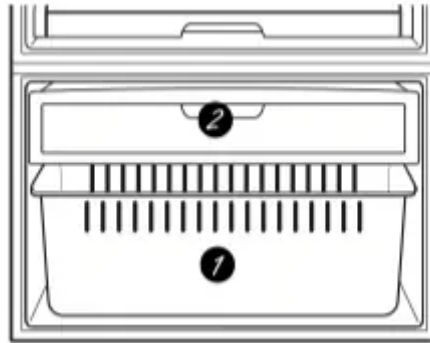

1. Basket.
2. Drawer.

Basket Removal

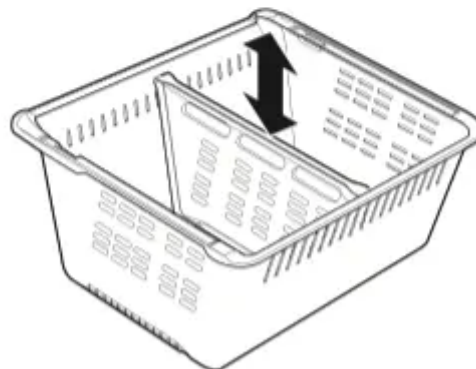
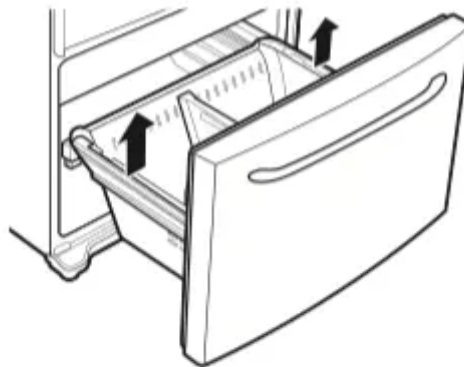

To remove:

1. Remove Freezer Bin. (See below.)
2. Pull basket out to the stop position.
3. Tilt up the rear of the bin.
4. Lift it out to remove.

To replace:

1. Place the basket into the rail assembly.

Basket Divider Removal

To remove:

1. Pull basket out to the stop position.
2. Tilt up the rear of the bin.
3. Lift it out to remove.

To replace:

1. Hook the top corners of the divider over the hole of the basket.

Drawer Removal

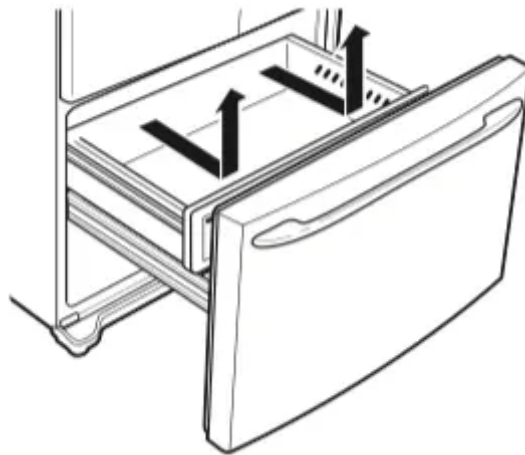

To remove: Pull the drawer forward and up to remove it from the rails.

To replace: Place the drawer wheels onto the rails and push back as you lower the drawer.

Non-Adjustable Bin in the Freezer

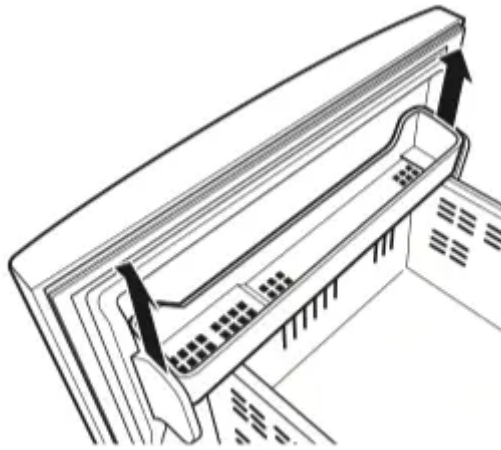

To remove: Pull the brackets upward until you hear a clicking sound and remove the bin.

To replace: Hook the ends of the bin into both brackets and push down until the bin locks into place.

About the automatic icemaker.

A newly installed refrigerator may take 12 to 24 hours to begin making ice.

Automatic Icemaker

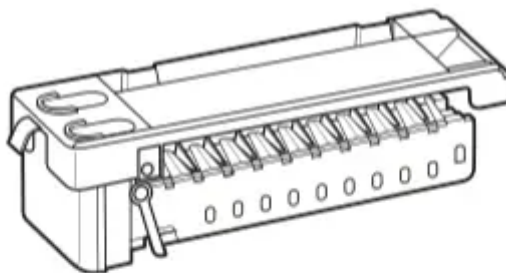

The unit comes with an icemaker installed. The icemaker cycle will depend on the freezer compartment temperature, room temperature, number of door openings and other use conditions.

If the refrigerator is operated before the water connection is made to the icemaker, press and release the Ice Off/Lock or Ice Off pad on the control panel to disengage the icemaker.

When the refrigerator has been connected to the water supply, press and release the Ice Off/Lock or Ice Off pad on the control panel to engage the icemaker.

A newly installed refrigerator may take 12 to 24 hours to begin making ice cubes.

You will hear a buzzing sound each time the icemaker fills with water.

Throw away the first few batches of ice to allow the water line to clear.

Be sure nothing interferes with the sweep of the feeler arm.

When the bin fills to the level of the feeler arm, the icemaker will stop producing ice. It is normal for several cubes to be joined together.

If ice is not used frequently, old ice cubes will become cloudy, taste stale and shrink.

NOTE: In homes with lower-than-average water pressure, you may hear the icemaker cycle multiple times when making one batch of ice.

NOTE: Turn on the Ice Off feature if the water supply is shut off.

Care and cleaning of the refrigerator

Cleaning the Outside

The door handles and trim. Clean with a cloth dampened with soapy water. Dry with a soft cloth. Do not use wax on the door handles and trim.

Keep the outside clean. Wipe with a clean cloth lightly dampened with kitchen appliance wax or mild liquid dish detergent. Dry and polish with a clean, soft cloth.

Do not wipe the refrigerator with a soiled dish cloth or wet towel. These may leave a residue that can erode the paint. Do not use scouring pads, powdered cleaners, bleach or cleaners containing bleach because these products can scratch and weaken the paint finish.

The stainless steel panels and door handles. Stainless steel (on some models) can be cleaned with a commercially available stainless steel cleaner. A spray-on stainless steel cleaner works best.

NOTE: The protective film may leave a residue that will need to be cleaned.

Do not use appliance wax, polish, bleach, abrasive cleaners or other products containing chlorine on stainless steel. Using cleaners with chlorine, such as bleach, may permanently affect the appearance of your new refrigerator.

Silver-accented plastic parts. Wash parts with soap or other mild detergents. Wipe clean with a sponge, damp cloth or paper towel.

Do not scrub with steel-wool pads or other abrasive cleaners.

Cleaning the Inside

To help prevent odors, leave an open box of baking soda in the refrigerator and freezer compartments.

Unplug the refrigerator before cleaning.

If this is not practical, wring excess moisture out of sponge or cloth when cleaning around switches, lights or controls.

Use an appliance wax polish on the inside surface between the doors.

Use warm water and baking soda solution about a tablespoon (15 ml) of baking soda to a quart (1 liter) of water. This both cleans and neutralizes odors. Rinse and wipe dry.

After cleaning the door gaskets, apply a thin layer of petroleum jelly to the door gaskets at the hinge side. This helps keep the gaskets from sticking and bending out of shape.

Avoid cleaning cold glass shelves with hot water because the extreme temperature difference may cause them to break. Handle glass shelves carefully. Bumping tempered glass can cause it to shatter.

Do not wash any plastic refrigerator parts in the dishwasher.

Silver-accented plastic parts. Wash parts with soapy water. Wipe clean with a sponge, damp cloth or paper towel.

Do not scrub with steel-wool pads or other abrasive cleaners.

Behind the Refrigerator

Be careful when moving the refrigerator away from the wall. All types of floor coverings can be damaged, particularly cushioned coverings and those with embossed surfaces.

Raise the leveling legs located at the bottom front of the refrigerator.

See Level the Refrigerator in the Installation Instructions for leveling leg details.

Pull the refrigerator straight out and return it to position by pushing it straight in. Moving the refrigerator in a side direction may result in damage to the floor covering or refrigerator.

Lower the leveling legs until they touch the floor.

When pushing the refrigerator back, make sure you don't roll over the power cord or icemaker supply line (on some models) and ensure the anti-tip bracket is engaged (if equipped).

Preparing for Vacation



For long vacations or absences, remove food and unplug the refrigerator. Clean the interior with a baking soda solution of one tablespoon (15 ml) of baking soda to one quart (1 liter) of water. Leave the doors open.

Press and release the Ice Off/Lock or Ice Off pad on the control panel to disengage the icemaker.

If the temperature can drop below freezing, have a qualified servicer drain the water supply system (on some models) to prevent serious property damage due to flooding.

Preparing to Move

Secure all loose items such as base grille, shelves and drawers by taping them securely in place to prevent damage.

When using a hand truck to move the refrigerator, do not rest the front or back of the refrigerator against the hand truck. This could damage the refrigerator. Handle only from the sides of the refrigerator.

Be sure the refrigerator stays in an upright position during moving.

Replacing the light bulbs.

Refrigerator Lights

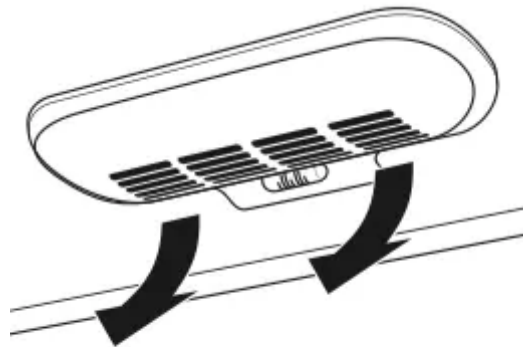

1. Unplug the power cord from the outlet.

2. Rotate the shield down while depressing the two tabs on the back side of the cover to remove it.
3. Turn the bulb counterclockwise.
4. Replace with an appliance bulb of the same or lower wattage.
5. Replace the shield.
6. Plug the refrigerator back in.

NOTE: Reveal[®] appliance bulbs may be ordered from GE Parts and Accessories, 800.626.2002

Freezer Light

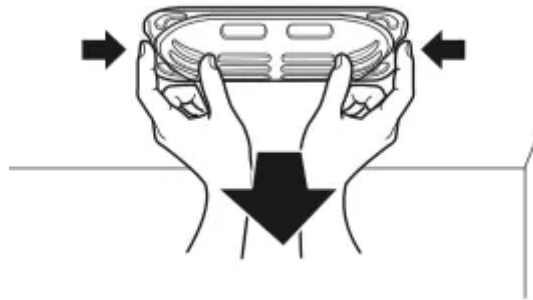

CAUTION: Light bulbs may be hot.

1. Unplug the power cord from the outlet.
2. Pull drawer out to the stop position.
3. Push the clips in on each side, and pull down and forward.
4. Turn the bulb counterclockwise.
5. Replace with an appliance bulb of the same or lower wattage.
6. Replace the shield.
7. Plug the refrigerator back in.

NOTE: Appliance bulbs may be ordered from GE Parts and Accessories, 800.626.2002.

Troubleshooting Tips

Normal operating sounds.

Newer refrigerators sound different from older refrigerators. Modern refrigerators have more features and use newer technology.

Do you hear what I hear? These sounds are normal.

HUMMM... WHOOSH...

- The new high efficiency compressor may run faster and longer than your old refrigerator and you may hear a high-pitched hum or pulsating sound while it is operating.
- You may hear a whooshing sound when the doors close. This is due to pressure equalizing within the refrigerator.



- You may hear the fans spinning at high speeds. This happens when the refrigerator is first plugged in, when the doors are opened frequently or when a large amount of food is added to the refrigerator or freezer compartments. The fans are helping to maintain the correct temperatures.
- The fans change speeds in order to provide optimal cooling and energy savings.

CLICKS, POPS, CRACKS and SNAPS

- You may hear cracking or popping sounds when the refrigerator is first plugged in. This happens as the refrigerator cools to the correct temperature.
- The freezer control will click when starting or stopping the compressor.
- Expansion and contraction of cooling coils during and after defrost can cause a cracking or popping sound.
- On models with an icemaker, after an icemaking cycle, you may hear the ice cubes dropping into the ice bucket.
- On models with a dispenser, during water dispense, you may hear the water lines move at initial dispense and

WATER SOUNDS



- The flow of refrigerant through the freezer cooling coils may make a gurgling noise like boiling water.
- Water dropping on the defrost heater can cause a sizzling, popping or buzzing sound during the defrost cycle.
- A water dripping noise may occur during the defrost cycle as ice melts from the evaporator and flows into the drain pan.
- Closing the door may cause a gurgling sound due to pressure equalization.

after dispenser button is released.

Before you call for service...

Troubleshooting Tips

Save time and money! Review the charts on the following pages first and you may not need to call for service.

| Problem | Possible Causes | What To Do |
|---|---|---|
| Refrigerator does not operate | <ol style="list-style-type: none">1. Refrigerator in defrost cycle.2. Refrigerator is unplugged.3. The fuse is blown/ circuit breaker is tripped. | <ol style="list-style-type: none">1. Wait about 30 minutes for defrost cycle to end.2. Push the plug completely into the outlet.3. Replace fuse or reset the breaker. |
| Vibration or rattling (slight vibration is normal) | Leveling legs need adjusting. | See Level the Refrigerator. |

| | | |
|---|---|---|
| <p>Motor operates for long periods or cycles on and off frequently. (Modern refrigerators with more storage space and a larger freezer require more operating time. They start and stop often to maintain even</p> | <ol style="list-style-type: none"> 1. Normal when refrigerator is first plugged in. 2. Often occurs when large amounts of food are placed in refrigerator. 3. Door left open. 4. Hot weather or frequent door openings. 5. Temperature control set at the coldest setting. | <ol style="list-style-type: none"> 1. Wait 24 hours for the refrigerator to completely cool down. 2. This is normal. 3. Check to see if package is holding door open. 4. This is normal. 5. See About the controls. |
| <p>Refrigerator or freezer compartment too warm</p> | <ol style="list-style-type: none"> 1. Temperature controls not set cold enough. 2. Warm weather or frequent door openings. 3. Door left open. | <ol style="list-style-type: none"> 1. See About the controls. 2. Set the temperature control one step colder. See About the controls. 3. Check to see if package is holding door open. |
| <p>Frost or ice crystals on frozen food (frost within package is normal)</p> | <ol style="list-style-type: none"> 1. Door left open. 2. Door openings too frequent or too long. | <ol style="list-style-type: none"> 1. Check to see if package is holding door open. |
| <p>Frequent “buzzing” sound</p> | <p>Ice Off feature is turned off, but the water supply to the refrigerator has not been connected.</p> | <p>Press and release the Ice Off/Lock pad on the control panel to turn on the Ice Off feature, and then the  icon will be displayed. Keeping the Ice Off feature on will damage the water valve.</p> |
| <p>Small or hollow cubes</p> | <p>Water filter clogged.</p> | <p>Replace filter cartridge with new cartridge or with plug.</p> |

| | | |
|---|---|--|
| <p>Automatic icemaker does not work</p> | <ol style="list-style-type: none"> 1. Ice Off feature is turned on. 2. Water supply turned off or not connected. 3. Freezer compartment too warm. 4. Piled up cubes in the storage bin cause the icemaker to shut off. 5. Ice cubes stuck in icemaker. | <ol style="list-style-type: none"> 1. Press and release the Ice Off/Lock pad on the control panel to turn off the Ice Off feature, and then the  icon will disappear. 2. See Installing the water line. 3. Wait 24 hours for the refrigerator to completely cool down. 4. Level cubes by hand. 5. Turn off the icemaker, remove cubes and turn the icemaker back on. |
| <p>Not cooling. OF/OF appears in the refrigerator door display</p> | <p>The cooling system is off.</p> | <p>Controls on Refrigerator Door:</p> <p>Press and hold the ADJUST FREEZER and ENERGY SAVER pads at the same time for 3 seconds. You will hear a beep and the OF/OF will disappear. You can now adjust the temperature. Please allow 24 hours for the unit to cool to your set temperature.</p> |
| <p>Not cooling. OFF/OFF appears in the display inside the fresh food compartment</p> | <p>The cooling system is off.</p> | <p>Controls Inside the Fresh Food Compartment:</p> <p>Press and hold the ICE OFF and FREEZER pads at the same time for 3 seconds. You will hear a beep and the OFF/OFF will disappear. You can now adjust the temperature. Please allow 24 hours for the unit to cool to your set temperature.</p> |

| | | |
|---|---|---|
| <p>Ice cubes have odor/ taste</p> | <ol style="list-style-type: none"> 1. Food transmitting odor/ taste to ice cubes. 2. Interior of refrigerator needs cleaning. | <ol style="list-style-type: none"> 1. Wrap foods well. 2. See Care and cleaning. <p>Keep an open box of baking soda in the refrigerator; replace every three months.</p> |
| <p>Slow ice cube freezing</p> | <ol style="list-style-type: none"> 1. Door left open. 2. Freezer control not set cold enough. | <ol style="list-style-type: none"> 1. Check to see if package is holding door open. 2. See About the controls. |
| <p>Refrigerator has odor</p> | <ol style="list-style-type: none"> 1. Foods transmitting odor to refrigerator. 2. Interior needs cleaning. | <ol style="list-style-type: none"> 1. Foods with strong odors should be tightly wrapped. <p>Keep an open box of baking soda in the refrigerator; replace every three months.</p> <ol style="list-style-type: none"> 2. See Care and cleaning. |
| <p>Moisture forms on outside of refrigerator</p> | <p>Not unusual during periods of high humidity.</p> | <p>Wipe surface dry and reset the refrigerator control one setting colder.</p> <p>Turn off Energy Saver mode.</p> |
| <p>Moisture collects inside (in humid weather, air carries moisture into refrigerator when doors are opened)</p> | <p>Too frequent or too long door openings.</p> | |
| | <ol style="list-style-type: none"> 1. No power at outlet. | <ol style="list-style-type: none"> 1. Replace fuse or reset the breaker. |



| | | |
|--|---|---|
| Refrigerator or freezer compartment light does not work | 2. Light bulb burned out or loose. | 2. See Replacing the light bulbs. |
| Door/drawer does not close by itself | Leveling legs need adjusting. | See Installing the Refrigerator. |
| Hot air from bottom of refrigerator | Normal air flow cooling motor. In the refrigeration process, it is normal that heat be expelled in the area under the refrigerator. Some floor coverings will discolor at these normal and safe temperatures. | |
| Food freezing in the refrigerator | <ol style="list-style-type: none"> 1. Food too close to the air vent at the back of the refrigerator. 2. Refrigerator control is set too cold | <ol style="list-style-type: none"> 1. Move the food away from the air vent. 2. Move the refrigerator control to a warmer temperature setting one increment at a time. |
| Water filter indicator light changed color | This is normal. | <p>The water filter indicator light shows the following: Green = Good Orange = Change soon Red = Change immediately</p> <p>See About the water filter for more information</p> |



| | | |
|---|---|--|
| Water has poor taste/odor | Water dispenser has not been used for a long time. | Dispense water until all water in system is replenished. |
| Water in first glass is warm | <ol style="list-style-type: none"> 1. Normal when refrigerator is first installed. 2. Water dispenser has not been used for a long time. 3. Water system has been drained. | <ol style="list-style-type: none"> 1. Wait 24 hours for the refrigerator to completely cool down. 2. Dispense water until all water in system is replenished. 3. Allow several hours for replenished supply to chill. |
| Water dispenser does not work | <ol style="list-style-type: none"> 1. Water supply line turned off or not connected. 2. Water filter clogged. 3. Air may be trapped in the water system. 4. Water in reservoir is frozen because the controls are set too cold. | <ol style="list-style-type: none"> 1. See Installing the water line. 2. Replace filter cartridge or remove filter and install plug. 3. Press the dispenser arm for at least 2 minutes. 4. Set the refrigerator control to a warmer setting and wait 24 hours. If water does not dispense after 24 hours, call for service. |
| Flow of water to dispenser or icemaker is slow | Water filter clogged. | Replace filter cartridge or remove filter and install plug. |
| Water spurting from dispenser | Newly installed filter cartridge. | Run water from the dispenser for 3 minutes (about 1 1/2 gallons). |

| | | |
|--|---|--|
| <p>No water or ice cube production</p> | <ol style="list-style-type: none"> 1. Supply line or shutoff valve is clogged. 2. Water filter clogged. 3. Filter cartridge not properly installed. | <ol style="list-style-type: none"> 1. Call a plumber. 2. Replace filter cartridge or remove filter and install plug. 3. Remove and reinstall filter cartridge, being certain that it locks into place. The blade on the end of the cartridge should be positioned vertically. |
| <p>Water is leaking from dispenser</p> | <ol style="list-style-type: none"> 1. Glass not being held under the dispenser long enough after button is released. 2. Air may be present in the water line system, causing water to drip after being dispensed. | <ol style="list-style-type: none"> 1. Hold the glass underneath the dispenser for 2–3 seconds after releasing the dispenser button. Water may continue to dispense after the button is released. 2. Dispense water for at least 2 minutes to remove air from system. |
| <p>Handle is loose / handle has a gap</p> | <p>Handle needs adjusting.</p> | <p>See Attach the Fresh Food handle and Attach the Freezer handle sections for detailed instructions.</p> |
| <p>Refrigerator beeping</p> | <p>This is the door alarm.</p> | <p>Close door.</p> |

Warning

This content is compiled from multiple sources and is provided for reference purposes only. It may not be complete or fully applicable to all situations. If you are unable to resolve your issue, please contact the product manufacturer or an authorized service provider for official support.

