

Using your microwave oven

Cooking has never been easier than with your new Samsung microwave oven. The following section describes everything you need to know about using your microwave oven.

Kitchen Timer button

This microwave allows you to use your microwave oven as a timer.

1. Press the Kitchen Timer button.
2. Use the number buttons to set the length of time you want the timer to run.
3. Press the ENTER/START button.
4. The display counts down and beeps when the time has elapsed.
5. To cancel timer setting: Press STOP/CLEAR button once.

+30 sec button

This simplified control saves you time, letting you quickly start cooking at 100% power.

1. Press the +30 sec button for each 30 seconds you wish the food to be cooked for. For example, press it twice to cook it for one minute, and then press the ENTER/START button to start cooking.
2. Add 30 sec. to a cooking program already in progress by pressing the +30 sec button for every additional 30 seconds you wish to add.

Vent buttons (2 Speed & On/Off)

The vent removes steam and other vapors from the cooking surface. You can manually select the vent setting.

1. Press the Vent 2 Speed button to set the speed level.
2. Press the Vent On/Off button to turn the vent on.
3. Press the Vent On/Off button again to turn the vent off.

Light Hi/Lo/Off button

The Light button allows you to select a light setting for your microwave.

Press (times)	1	2	3
Light	High	Low	Off

Cooking Presets buttons

The Cooking Presets buttons let you cook favorite foods using preset power levels and times at the touch of a button. If the food is not thoroughly cooked or reheated when you use the Preset buttons, complete the cooking process by selecting a power level and cooking the food for an additional amount of time.

CAUTION

Do not use the Cooking Presets buttons continuously. You must let the oven cool for 5 minutes between uses or the food will overcook.

Auto cook table

Cooking Preset Button	Amount or Type	Number of Times to Press	Instructions
Popcorn	3.5 oz. 1 package	once	<p>Cook only one microwave popcorn bag at a time. Be careful when removing and opening the heated bag from the oven. Let the oven cool for at least 5 minutes before using it again.</p> <p>CAUTION Do not leave the microwave oven unattended while popcorn is being cooked!</p>
	3.0-3.5 oz. 1 package	twice	
Potato	1 potato	once	<p>Pierce each potato several times with a fork. Place them on the turntable in a spoke-like fashion. After cooking, let the potatoes stand for 3-5 minutes. Let the oven cool for at least 5 minutes before using it again.</p> <p>NOTE Pierce the potatoes with a fork several times before putting them in the microwave oven. The cooking times are based on average 8-10 oz. potatoes</p>
	2 potatoes	twice	
	3 potatoes	three times	
	4 potatoes	four times	
Pizza	1 slice	once	<p>Put 1-3 slices of pizza on a microwavesafe plate with the wide end of each slice toward the outside edge of the plate. Do not let slices overlap. Do not cover. Let the oven cool for at least 5 minutes before using again.</p>
	2 slice	twice	
	3 slice	three times	
Veggies	Fresh vegetables	once	<p>Place 1 to 4 servings of fresh / frozen vegetables in a microwave-safe ceramic, glass or plastic dish and add 2-4 Tbs. water. Cover with lid or vented plastic wrap to cook. Stir before letting stand for 3 to 5 minutes. Let oven cool for at least 5 minutes before using again</p>
	Frozen vegetables	twice	
Cook	Beverage Display: Ac-1	once	<p>Use measuring cup or mug. Do not cover. Place the beverage in the oven. After heating, stir well. Let oven cool for at least 5 minutes before using again.</p> <p>NOTE</p>

		<ul style="list-style-type: none"> • Reheat times based on an 8 ounce cup. • Beverages heated with the beverage feature may be very hot. • Remove container with care. Amount : 0.5 cup, 1 cup, 2 cup
Bacon Display: Ac-2	twice	Place 2 paper towels on a plate and arrange bacon on towels. Do not overlap. Cover with additional paper towel. Remove the paper towels immediately after cooking. Amount : 2 to 6 slices.
Frozen Dinner Display: Ac-3	three times	Remove food from outer wrapping and follow box instructions for covering and standing. Let oven cool for at least 5 minutes before using again. Amount : 8 to 14 oz.
Frozen Breakfast Display: Ac-4	four times	Follow the package instructions for covering and standing. Use this button for frozen sandwiches, breakfast entrees, etc. Let oven cool for at least 5 minutes before using again. Amount : 4 to 8 oz.

Reheat button

The Reheat button provides three preset reheating categories.

Category	Number of Times to Press	Display
Dinner plate	once	rh-1
Casserole	twice	rh-2
Pasta	three times	rh-3

Example: Reheating 3 servings of casserole.

1. Press the Reheat button twice.
2. Use the number buttons to enter the quantity or number of servings.
3. Press the ENTER/START button.
4. When the cooking time is over, four beeps will sound and End is displayed.

Reheating table

Follow the instructions below when reheating different types of food.

Category	Amount	Directions
Dinner plate	1 serving (1 plate)	Use only pre-cooked, refrigerated foods. Cover the plate with a vented plastic wrap or waxed paper tucked under the plate. If the food is not as hot as you would like after using the reheat function, continue heating using additional time and power. Contents: 3-4 oz. meat, poultry or fish (up to 6 oz. with bone) ½ cup starch (potatoes, pasta, rice, etc.) ½ cup vegetables (about 3-4 oz.)
Casserole Pasta	1 to 4 servings	Cover the plate with a lid or vented plastic wrap. If the food is not as hot as you would like after using the reheat function, continue heating using additional time and power. Stir the food once before serving. Contents: 3-4 oz. meat, poultry or fish (up to 6 oz. with bone) ½ cup starch (potatoes, pasta, rice, etc.) ½ cup vegetables (about 3-4 oz.)

NOTE

The 'right' temperature of the food varies from person to person. Allow food to stand 1 to 5 minutes before serving.

Auto Defrost button

The defrost choices are preset in the oven. The defrost cycle provides you with the best defrosting method for frozen foods, because the oven automatically sets the defrosting times according to the weight you enter. For added convenience, the auto defrost function beeps to remind you to check or turn over the food during the defrost cycle.

Press the Auto Defrost button once and select the food weight. The available weight ranges from 0.1 to 6.0 lbs.

1. Press the Auto Defrost button.
2. Use the number buttons to enter the weight.
3. Press the ENTER/START button.

NOTE

After pressing the ENTER/START button, the display counts down the defrosting time. The oven will beep twice during the defrost cycle. At this time, open the door and turn the food as needed. Remove any thawed portions, then return the frozen portions to the oven and press the ENTER/START button to resume the defrost cycle. The defrost cycle continues while the oven is beeping and only stops when the door is opened.

Defrosting tips

When using auto defrost, the entered weight is the net weight in pounds and tenths of pounds (the weight of the food minus the container). Use the auto defrost cycle for raw food only. The auto defrost cycle gives best results when the food you want to thaw is no colder than 0°F (taken directly from a true freezer). If food has been stored in a refrigerator-freezer that does not maintain a temperature of 5°F or below, always program a lower food weight (for a shorter defrosting time) to prevent the food from cooking. If the food is stored outside the freezer for up to 20 minutes, enter a lower food weight.

The shape of the package alters the defrosting time. Shallow rectangular packets defrost more quickly than a thick block. Separate the pieces as they begin to defrost. Separated pieces defrost more easily. Shield areas of food with small pieces of foil if they start to become warm. You can use small pieces of aluminum foil to shield foods such as chicken wings, leg tips, and fish tails, but the foil must not touch the sides of the oven as foil causes arcing, which can damage the oven lining.

Auto defrosting table

Follow the instructions below when defrosting different types of food

category	Standard amount	Procedure
Roast Beef, Pork	2.5-6.0 lbs.	Start with the food placed fat side down. After each stage, turn the food over and shield any warm portions with narrow strips of aluminum foil.
Steaks, Chops, Fish	0.5-3.0 lbs.	After each stage, rearrange the food. If there are any warm or thawed portions of food, shield them with narrow, flat pieces of aluminum foil. Remove any pieces of food that are nearly defrosted. Let stand, covered for 5 - 10 minutes.
Ground Meat	0.5-3.0 lbs.	After each stage, remove any pieces of food that are nearly defrosted. Let stand covered with foil for 5 - 10 minutes
Whole Chicken	2.5-6.0 lbs.	Remove giblets before defrosting poultry. Start defrosting with the breast side down. After the first stage, turn the chicken over and shield any warm portions with narrow strips of aluminum foil. After the second stage, again shield any warm portions with narrow strips of aluminum foil. Let stand, covered, for 30 - 60 minutes in the refrigerator.
Chicken Pieces	0.5-3.0 lbs.	After each stage, rearrange or remove any pieces of food that are nearly defrosted. Let stand for 10 - 20 minutes.
Bread	0.1 - 2.0 lbs	Arrange the rolls in a circle on kitchen paper in the middle of the turntable. Turn over halfway through the defrosting time.

Soften/Melt button

Soften/Melt lets you melt chocolate, soften cream cheese, and melt butter.

1. Touch the Soften/Melt button.
2. Choose the food category by pressing the Soften/Melt button.
3. Press the number button (1,2 or 3) for amount or serving.
4. Touch the ENTER/START button.

Soften / Melt table



Function	Amount or servings	Remarks
Melt chocolate	2 squares or 1 cup chips	Place chocolate chips or square in a microwave-safe dish. Stir well at half time when the oven beeps, and re-start the oven. Unless stirred, the chocolate keeps its shape even when heating time is over.
Soften cream cheese	1 package (8 oz.)	Unwrap the cream cheese and place on microwave-safe dish. Let stand 1-2 minutes.
Melt butter	1 stick (1/4 lb.)	Remove wrapping and cut butter in half vertically. Place butter in dish, cover with wax paper. Stir well after finishing and let stand 1-2 minutes.
	2 sticks (1/2 lb.)	

Microwave Cooking Times & Power Levels

The power level lets you control the heating intensity from Warm (1) to High (10).

Cooking at high power levels

1. Use the number buttons to enter the cooking time.
2. Press the ENTER/START button.
3. When the cooking time is over, four beeps will sound and End is displayed.

NOTE

If you do not enter a power level, the microwave oven cooks at the High Power Level by default.

Cooking at lower power levels

Cooking at high power does not always give you the best results with foods that require slower cooking, such as roasts, baked goods, or custards. Your oven has 9 additional power settings in addition to high.

1. Use the number buttons to enter the cooking time.

NOTE

When selecting more than one cooking stage, you must press the Power Level button before you can enter the second cooking stage.

NOTE

Press the Power Level button twice to set the power level to High for a cooking stage.

1. Press the Power Level button.

2. Use the number buttons to enter the power level.
3. Press the ENTER/START button.
4. When the cooking time is over, four beeps will sound and End is displayed.

Cooking with more than one cook cycle

For best results, some recipes call for one Power Level for a certain length of time, and another Power Level for another length of time. Your oven can be set to change from one to another automatically, if the first cycle is the defrost cycle.

1. Use the number buttons to enter the cook time.
2. Press the Power Level button.
3. Use the number buttons to enter the power level.
4. Use the number buttons to enter the second cook time.
5. Press the Power Level button.
6. Use the number buttons to enter the power level.
7. Press the ENTER/START button.
8. When the cooking time is over, four beeps will sound and End is displayed.

Power Levels

The 10 power levels allow you to choose the optimal power level for your cooking needs.

Power level	Microwave output	Use
10 (High)	100 %	Boiling water. Cooking ground beef. Making candy. Cooking fresh fruit and vegetables. Cooking fish and poultry. Preheating browning dish. Reheating beverages. Bacon slices.
9	90 %	Reheating meat slices quickly. Sautéing onions, celery, and green pepper
8	80 %	Reheating all types of items (Dinner plate, pasta, meat, soup or sauce, etc.). Cooking scrambled eggs
7	70 %	Cooking breads and cereal products. Cooking cheese dishes, veal. Cooking cakes, muffins, brownies, cupcakes.
6	60 %	Cooking pasta.
5	50 %	Cooking meats, whole poultry. Heating custard Cooking whole chickens, turkey, spare ribs, rib roasts, sirloin roasts.
4	40 %	Cooking less tender cuts of meat. Reheating frozen convenience foods.
3	30 %	Thawing meat, poultry, and seafood.

		<p>Cooking small quantities of food.</p> <p>Finishing cooking casserole, stew, and some sauces.</p>
2	20 %	<p>Softening butter and cream cheese.</p> <p>Heating small amounts of food.</p>
1	10 %	<p>Softening ice cream.</p> <p>Raising yeast dough</p>

Eco Mode

Eco Mode reduces standby power usage. When you press the Eco Mode button once, the display will go out and the microwave shifts to the mode which minimizes power usage. To cancel the Eco Mode, press Eco Mode button once again, or press any other button.

Cookware guide

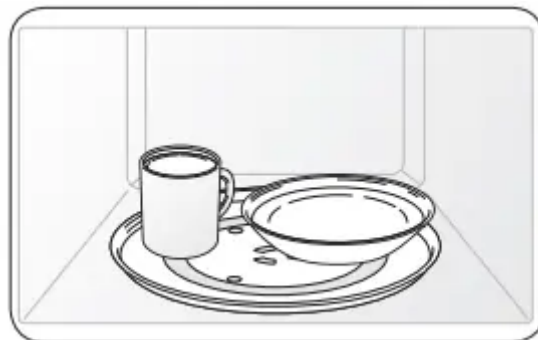

For food to cook in the microwave oven, the microwaves must be able to penetrate the food without being reflected or absorbed by the dish. It is important to choose the correct cookware, therefore, look for cookware that is marked microwave-safe. The following table lists various types of cookware and indicates if and how they should be used in a microwave oven.

Microwave-safe utensils

If you are not sure whether an item is microwave-safe or not, you can perform the following simple test:

1. Place 1 cup of water (in a glass-measuring cup) inside your oven next to the item to be tested.
2. Press the +30 sec button twice to heat them both for one minute at high power.

After one minute, the water should be warm and the item you are testing should be cool. If the dish is warm, then it is absorbing microwave energy and is not microwave-safe.

Cookware	Microwave-safe	Comments
Aluminum foil	✓✗	Can be used in small quantities to protect areas against overcooking. Arcing can occur if the foil is too close to the oven wall or you use too much foil.
Browning plate	✓	Do not preheat for more than eight minutes.
Ceramic, porcelain, and stoneware	✓	Porcelain, pottery, glazed earthenware and bone china are usually suitable, unless decorated with a metal trim.
Disposable polyester cardboard	✓	Some frozen foods are packaged in these materials.



Cookware	Microwave-safe	Comments
Fast-food packaging <ul style="list-style-type: none"> Polystyrene cups/containers Paper bags or newspaper Recycled paper or metal trims 	<p style="text-align: center;">✓</p> <p style="text-align: center;">✗</p> <p style="text-align: center;">✗</p>	<p>Can be used to warm food. Overheating may cause the polystyrene to melt.</p> <p>May catch fire.</p> <p>May cause arcing.</p>
Glassware <ul style="list-style-type: none"> Oven-to-table ware Fine glassware Glass jars 	<p style="text-align: center;">✓</p> <p style="text-align: center;">✓</p> <p style="text-align: center;">✓</p>	<p>Can be used, unless decorated with a metal trim.</p> <p>Can be used to warm foods or liquids. Delicate glass may break or crack if heated suddenly.</p> <p>Regular glass is too thin to be used in a microwave, and can shatter.</p>
Metal <ul style="list-style-type: none"> Dishes, Utensils Freezer bag twist ties 	<p style="text-align: center;">✗</p> <p style="text-align: center;">✗</p>	<p>May cause arcing or fire.</p>
Paper <ul style="list-style-type: none"> Plates, cups, napkins and kitchen paper Recycled paper 	<p style="text-align: center;">✓</p>	<p>For short cooking times and warming. Also to absorb excess moisture.</p> <p>Do not use recycled paper towels, which may contain metal and may catch fire or cause arcing.</p>

Cookware	Microwave-safe	Comments
Plastic		
• Containers	✓	Can be used if heat-resistant thermoplastic. Some plastics may warp or discolor at high temperatures. Do not use Melamine plastic.
• Cling film	✓	Can be used to retain moisture. Avoid wrapping the food too tightly. Take care when removing the film as hot steam will escape.
• Freezer bags	✓X	Only if boilable or oven-proof. Should not be airtight. Prick with a fork, if necessary.
Wax or grease-proof paper	✓	Can be used to retain moisture and prevent spattering.
Thermometer	✓	Use only those marked "Microwave-safe" and follow the directions. Check the temperature in several places. You can use conventional thermometers once the food has been removed from the oven.
Straw, wicker, and wood	✓X	Use only for short-term heating, as these materials can be flammable.

✓ : Recommended

✓X : Use caution

X : Unsafe to use / Do not

Cooking guide

Microwave energy actually penetrates food, attracted and absorbed by the water, fat and sugar in the food. The microwaves cause the molecules in the food to move rapidly. The rapid movement of these molecules creates friction and the resulting heat cooks the food.

General microwave tips

Dense foods, such as potatoes, take longer to heat than lighter foods. Foods with a delicate texture should be heated at a low power level to avoid becoming tough. Foods with a non-porous skin such as potatoes or hot dogs, should be pierced to prevent bursting.

Putting heating oil or fat in the microwave is not recommended. Fat and oil can suddenly boil over and cause severe burns.

Some ingredients heat faster than others. For example, the jelly in the jelly doughnut will be hotter than the dough. Keep this in mind to avoid burns. The altitude and the type of cookware you are using can affect the cooking time.

When trying a new recipe, use the minimum cooking time and check the food occasionally to prevent overcooking.

Home canning in the microwave oven is not recommended because not all harmful bacteria may be destroyed by the microwave heating process.

Although microwaves do not heat the cookware, the heat from the food is often transferred to the cookware. Always use pot holders when removing food from the microwave and instruct children to do the same.

Making candy in the microwave is not recommended as candy can be heated to very high temperatures. Keep this in mind to avoid injury.

Cooking techniques

NOTE

If the oven is set to cook for more than 25 minutes, it will automatically adjust to percent power after 25 minutes to avoid overcooking.

Stirring

Open the microwave door and stir foods such as casseroles and vegetables occasionally while cooking to distribute heat evenly. Food at the outside of the dish absorbs more energy and heats more quickly, so stir from the outside towards the center. The oven will turn off when you open the door to stir your food.

Arrangement

Arrange unevenly shaped foods, such as chicken pieces or chops, with the thicker, meatier parts toward the outside of the turntable where they can receive more microwave energy. To prevent overcooking, place thin or delicate parts towards the center of the turntable.

Shielding

Shield food with narrow strips of aluminum foil to prevent overcooking. Areas that need shielding include poultry wing-tips, the ends of poultry legs, and corners of square baking dishes. Use only small amounts of aluminum foil. Larger amounts can damage your oven.

Turning

Turn foods over midway through the cooking cycle to expose all parts to the microwave energy. This is especially important with large items such as roasts.

Standing

Foods cooked in the microwave build up internal heat and continue to cook for a few minutes after the oven stops. Let foods stand to complete the cooking process, especially foods such as roasts and whole vegetables. Roasts need this time to complete cooking in the center without overcooking the outer areas. All liquids, such as soup or hot chocolate should be shaken or stirred when cooking is complete. Let liquids stand a moment before serving. When heating baby food, stir well and test the temperature before serving.

Adding moisture

Microwave energy is attracted to water molecules. Food that is uneven in moisture content should be covered or allowed to stand so that the heat disperses evenly. Add a small amount of water to dry food to help it cook.

Venting

After covering a dish with plastic wrap, vent the plastic wrap by turning back one corner to let excess steam escape.

Cooking meat

Place the meat fat side down on a microwave-safe roasting rack in a microwavesafe dish. Use narrow strips of aluminum foil to shield any bone tips or thin pieces of meat. Check the temperature in several places before letting the meat stand the recommended time. The following temperatures are the removal temperatures. The temperature of the food will rise during standing time

Food	Cooking time/Power level	Instructions
Roast beef (boneless) Up to 4 lbs.	Cooking Time: 10-15 min./lb. for 145 °F - Rare 12-17 min./lb. for 160 °F - Medium 14-19 min./lb. for 170 °F - Well Done	Place the roast fat-side down on the roasting rack and cover with wax paper. Turn over halfway through the cooking process. Let stand for 10 to 15 minutes.
	Power Level: High (10) for first 5 minutes, then Medium (5).	
Pork (boneless or bone-in) Up to 4 lbs.	Cooking Time: 15-20 min./lb. at 170 °F Well Done	Place the roast fat-side down on the roasting rack and cover with wax paper. Turn over halfway through cooking process. Let stand for 10 to 15 minutes.
	Power Level: High (10) for first 5 minutes, then Medium (5).	

The following temperatures are the removal temperatures. The temperature of the food will rise during standing time. Expect a 10 °F rise in temperature during the standing time.

Food		Remove from oven	After standing (10 MIN.)
Beef	Rare	135 °F	145 °F
	Medium	150 °F	160 °F
	Well Done	160 °F	170 °F
Pork	Medium	150 °F	160 °F
	Well Done	160 °F	170 °F
Poultry	Dark meat	170 °F	180 °F
	Light meat	160 °F	170 °F

Cleaning and maintaining your microwave oven

Keeping your microwave oven clean improves its performance, wards off unnecessary repairs, and lengthens its life.

Cleaning the exterior

It's best to clean spills on the outside of your microwave oven as they occur. Use a soft cloth and warm, soapy water. Rinse and dry.

CAUTION

Do not get water into the vents. Never use abrasive products or chemical solvents such as ammonia or alcohol as they can damage the appearance of your microwave.

Cleaning under your microwave oven

Regularly clean grease and dust from the bottom of your microwave using a solution of warm water and detergent.

Cleaning the control panel

Wipe with a damp cloth and dry thoroughly. Do not use cleaning sprays, large amounts of soap and water, abrasives or sharp objects on the panel as it is easily damaged.

Cleaning the door and door seals

Always ensure that the door seals are clean and that the door closes properly. Take particular care when cleaning the door seals to ensure that no particles accumulate and prevent the door from closing correctly. Wash the glass door with very mild soap and water. Be sure to use a soft cloth to avoid scratching. If a thin film of water accumulates on the inside or outside of the oven door, wipe it off with a soft cloth. A thin water film can accumulate when you operate the oven at high humidity and in no way indicates microwave leakage.

Cleaning the interior

CAUTION

Ensure that the microwave oven has cooled down before cleaning it to avoid injury.

CAUTION

Remove the glass tray from the oven when cleaning the oven or tray. To prevent the tray from breaking, handle it with care and do not put it in water immediately after cooking. Wash the tray carefully in warm sudsy water or in the dishwasher.

Clean the interior surfaces (oven cavity) of your microwave oven periodically to remove any splashes or stains. To remove hardened food articles and remove smells, place 2 cups of water (add lemon juice for extra freshness) into a four-cup measuring glass. Run the microwave at High power for 5 minutes or until the water boils. Let water stand in the oven for one or two minutes.

Cleaning the turntable and roller rings

Clean the roller rings periodically and wash the turntable as required. You can wash the turntable safely in your dishwasher.

Storing and repairing your microwave oven

If you need to store your microwave oven for a short or extended period of time, choose a dust-free, dry location. Dust and dampness may adversely affect the ability of the microwave parts.

WARNING

- Do not repair, replace or service any part of your microwave oven yourself. Allow only a qualified service technician to perform repairs. If the oven is faulty and needs servicing, or you are in doubt about its condition, unplug the oven from the power outlet and contact your nearest service center.
- Do not use the oven if it is damaged, in particular, if the door or door seals are damaged. Door damage includes a broken hinge, a worn out seal, or distorted/ bent casing.
- Do not remove the oven from its casing.
- This microwave oven is for home use only and is not intended for commercial use.

Replacing the cooktop/night light

When replacing the cooktop/night light, make sure that you are wearing gloves to avoid injury from the heat of the bulb.

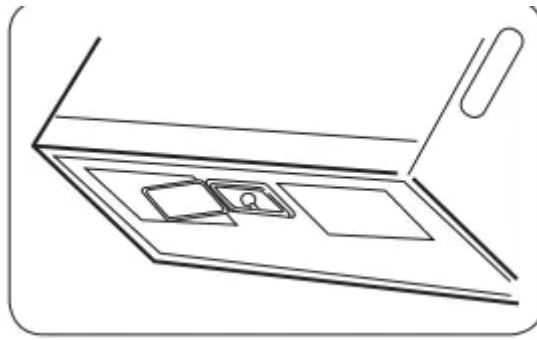

1. Unplug the oven or turn off the power at the main power supply.
2. Remove the screw from the light cover and lower the cover.
3. Replace bulb with 40 watt incandescent bulb.
4. Replace the light cover and mounting screw.
5. Turn the power back on at the main power supply

Replacing the oven light

When replacing the oven light, make sure that you are wearing gloves to avoid injury from the heat of the bulb.

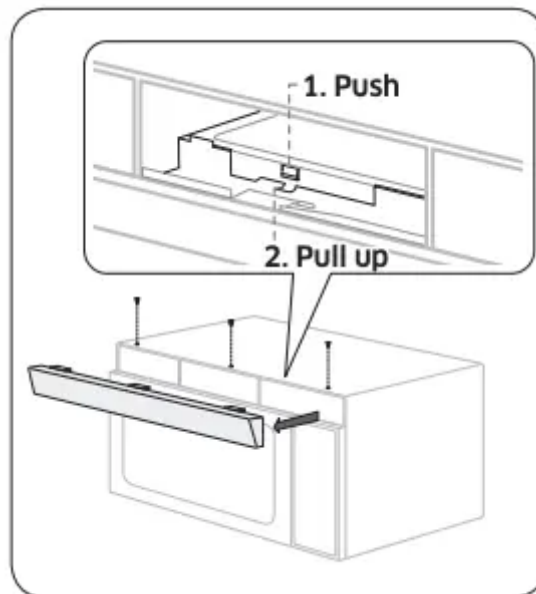

1. Unplug the oven or turn off the power at the main power supply.
2. Open the door.
3. Remove the vent cover mounting screws (middle screws).
4. Slide the vent grille to the left, then pull it straight out.
5. Remove the charcoal filter, if present.
6. Remove the cover by pushing the hook and pulling up the lever.
7. Remove the bulb by turning it gently.

8. Replace the bulb with a 40 watt appliance bulb.
9. Replace the bulb holder.
10. Replace the vent grille and the 3 screws.
11. Turn the power back on.

Cleaning the grease filter

Your microwave oven has two metal reusable grease filters. The grease filters should be removed and cleaned at least once a month, or as required.

WARNING

To avoid risk of personal injury or property damage, do not operate the oven hood without the filters in place.

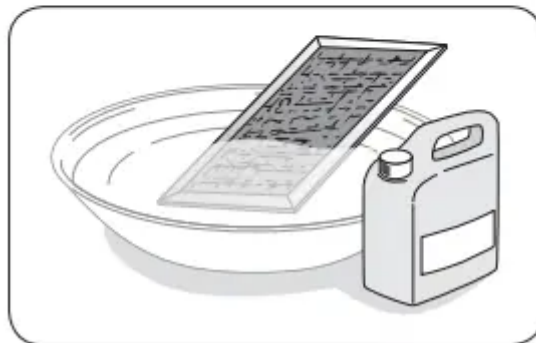
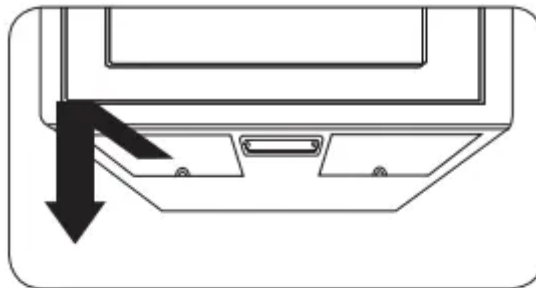

1. To remove the filter, slide it to the left (or right) using the tab.
2. Soak the grease filter in hot water and a mild detergent. Rinse well and shake to dry. Brushing the filter lightly can remove embedded dirt.

WARNING Do not use ammonia or put the grease filter in the microwave oven. The aluminum will darken.

3. To return the filter to its position, slide it into the frame slot on the left (or right), then push it upwards and to the right (or left) to lock it.

Replacing the charcoal filter

If your oven is vented to the inside, the charcoal filter should be replaced every 6 to 12 months and more often if necessary. The charcoal filter cannot be cleaned. To order a new charcoal filter, contact the Parts Department at 1-800-627-4368 or your Samsung dealer

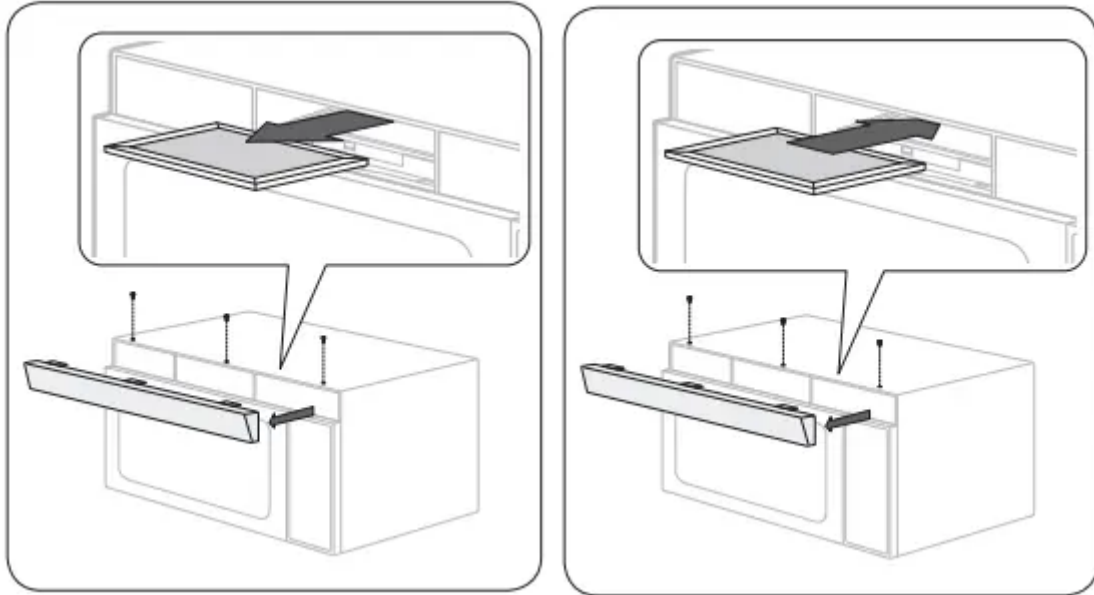

1. Unplug the oven or turn off the power at the main power supply.
2. Open the door.
3. Remove the vent grille mounting screws (middle screws).
4. Slide the vent grille to the left, then pull it straight out.
5. Push the hook and remove the old filter.
6. Slide a new charcoal filter into place. The filter should rest at the angle shown.
7. Replace the vent grille and 3 screws and close the door. Turn the power back on and set the clock.

Troubleshooting

Check these solutions if you have a problem with your microwave:

Problem	Solution
<p>The display and/ or the oven is not working.</p>	<p>Make sure the plug is properly connected to a grounded outlet.</p> <p>If the wall outlet is controlled by a wall switch, make sure the wall switch is turned on.</p> <p>Remove the plug from the outlet, wait ten seconds, and plug it in again.</p> <p>Reset the circuit breaker or replace any blown fuses.</p> <p>Plug a different appliance into the outlet. If the other appliance doesn't work, call a qualified electrician to repair the wall outlet.</p> <p>Plug the oven into a different outlet.</p>
<p>The display is working, but the power won't come on.</p>	<p>Make sure the door is closed securely.</p> <p>Check if any packaging material or anything else is stuck in the door seal.</p> <p>Check if the door is damaged.</p> <p>Touch Cancel twice and enter all the cooking instructions again.</p>
<p>Is the power going off before the set time has elapsed?</p>	<p>If there was a power outage, the time indicator will display: 88:88.</p> <p>If no power outage occurred, remove the plug from the outlet, wait ten seconds, and plug it in again. Reset the clock and any cooking instructions.</p> <p>Reset the circuit breaker or replace any blown fuses.</p>
<p>Cooks food too slowly.</p>	<p>Make sure the oven has its own 20 amp circuit line. Operating another appliance on the same circuit can cause a voltage drop. If necessary, move the oven to its own circuit.</p>
<p>Has sparks or arcing.</p>	<p>Remove any metallic utensils, cookware, or metal ties. If using foil, use only narrow strips and allow at least one inch between the foil and the interior oven walls.</p>
<p>The turntable makes noise or becomes stuck.</p>	<p>Clean the turntable, roller ring and oven floor.</p> <p>Make sure the turntable and roller ring are positioned correctly.</p>
<p>Causes TV or radio interference.</p>	



	This is similar to interference caused by other small appliances, such as hair dryers. Move your microwave (or appliance) away from appliances, such as your TV or radio.
Vent Motor suction force is too weak.	Set the vent mode to high. The Vent Fan will only operate in low speed mode while the microwave is working.
Operating noise is too loud.	The MWO makes noise during operation. This is normal. If you hear an abnormal sound continuously, please contact the Samsung Call Center (1-800-726-7864).
Cook top lamp is too dim.	Set the lamp brightness level to high.
Difficult to replace Charcoal Filter.	Please refer to the instructions for replacing the charcoal filter in the user's manual.
Turntable rotates improperly	Make sure you have not put too much food on the turntable. If the food is too large or too heavy, the turntable may operate improperly.

Warning

This content is compiled from multiple sources and is provided for reference purposes only. It may not be complete or fully applicable to all situations. If you are unable to resolve your issue, please contact the product manufacturer or an authorized service provider for official support.