

User Manual Cooktop

PARTS AND FEATURES

This manual covers different models. The cooktop you have purchased may have some or all of the items listed. The locations and appearances of the features shown here may not match those of your model.

Control Panels

WCE55US0H (30"[76.2 cm])

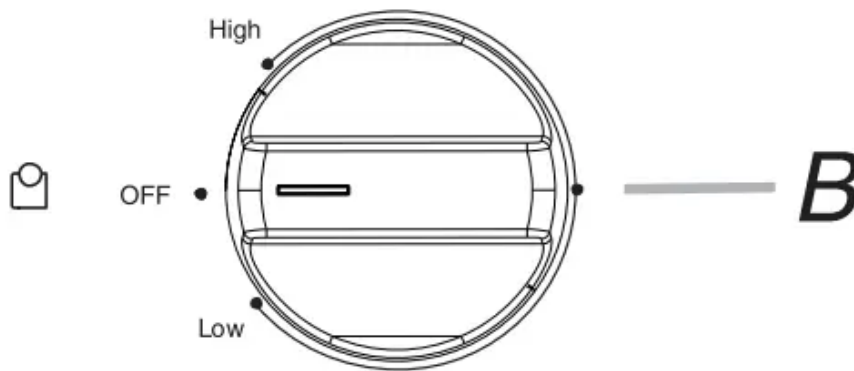
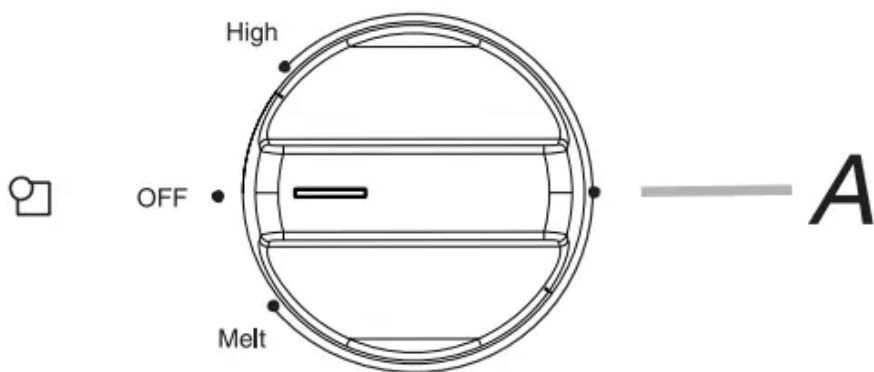

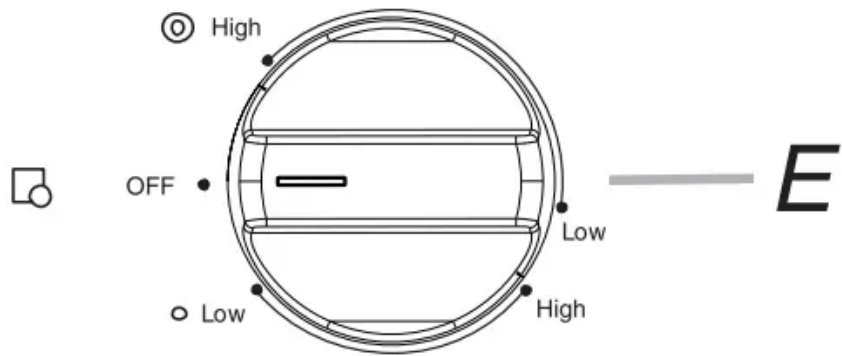
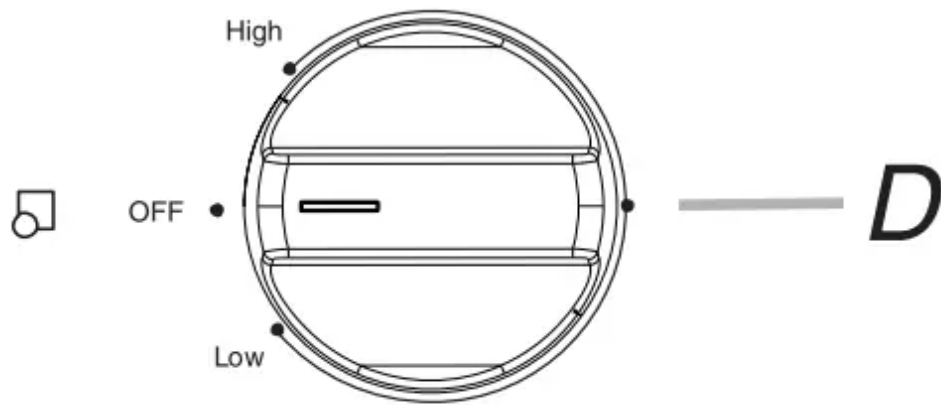
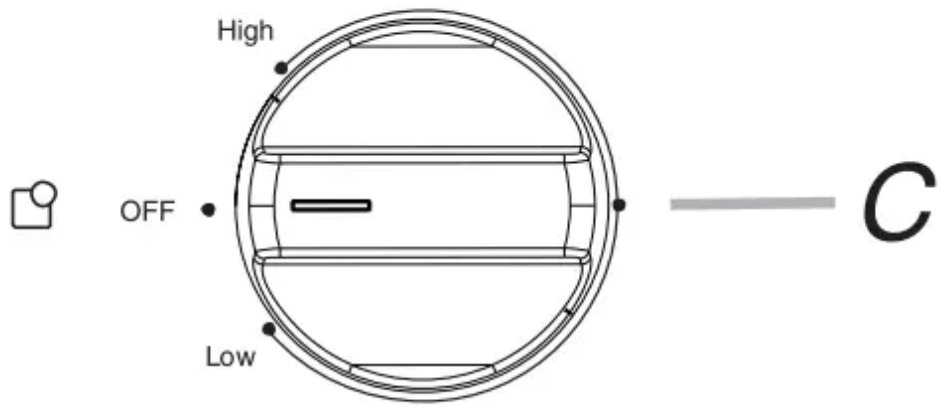

G — Cooktop On

F — Hot Surface

- A. Left rear control knob
- B. Center rear control knob
- C. Right rear control knob



- D. Left front control knob
- E. Right front control knob (dualzone burner)
- F. Hot surface indicator light
- G. Cooktop on indicator light

COOKTOP CONTROLS

WARNING

- Fire Hazard
- Turn off all controls when done cooking.
- Failure to do so can result in death or fire

The controls can be set to anywhere between Lo and Hi.

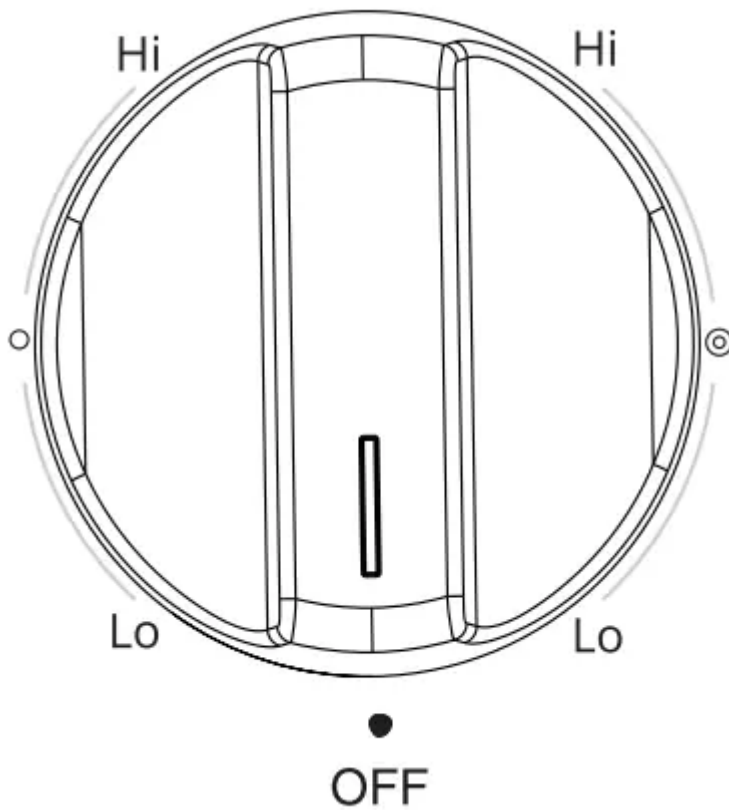

To Use:

1. Push in and turn knob to desired heat setting. Use the following chart as a guide when setting heat levels.

SETTING	RECOMMENDED USE
High	<ul style="list-style-type: none"> ■ Start food cooking. ■ Bring liquid to a boil.
Medium High	<ul style="list-style-type: none"> ■ Hold a rapid boil. ■ Quickly brown or sear food
Medium	<ul style="list-style-type: none"> ■ Maintain a slow boil. ■ Fry or sauté foods. ■ Cook soups, sauces and gravies. ■ High simmer or simmer without lids.
Medium Low	<ul style="list-style-type: none"> ■ Stew or steam food. ■ Simmer.
Low	<ul style="list-style-type: none"> ■ Keep food warm. ■ Melt chocolate or butter. ■ Low simmer using lids.
Dual/Triple Elements (on some models)	<ul style="list-style-type: none"> ■ Home canning. ■ Large-diameter cookware. ■ Large quantities of food.

REMEMBER: When cooktop is in use, the entire cooktop area may become hot.

Hot Surface Indicator Lights (on Standard Control models)

The Hot Surface Indicator Lights will glow as long as any surface cooking area is too hot to touch, even after the surface cooking area(s) is turned off.



If the cooktop is on when a power failure occurs, the Hot Surface Indicator Lights will remain on after the power is restored to the cooktop. They will remain on until the cooktop has cooled completely.

Power Light

Each cooktop has a Power On light. The light will glow when any burner is on.

Dual/Triple-Circuit Element (on some models)

The dual-size and triple-size elements offer flexibility depending on the size of the cookware. Single size can be used in the same way as a regular element. The dual and triple sizes combine single, dual and outer element and are recommended for larger cookware, large quantities of food, and home canning.

Triple Element (on some models)

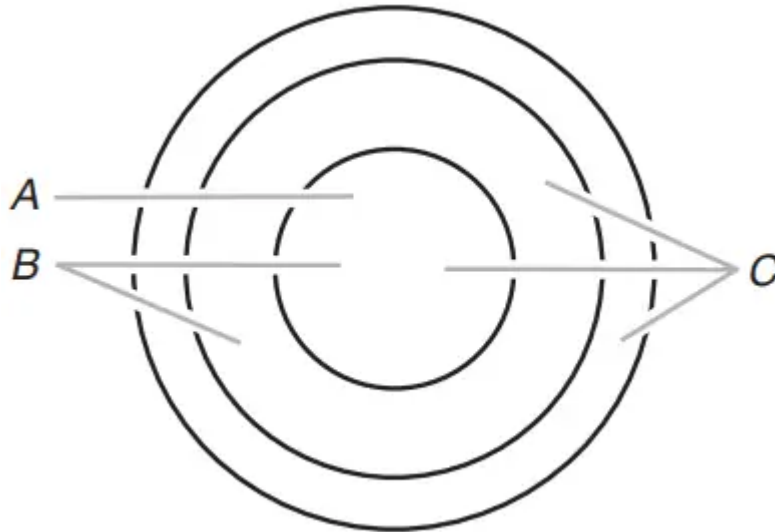

- A. Single size
- B. Dual size
- C. Triple size

Dual Element

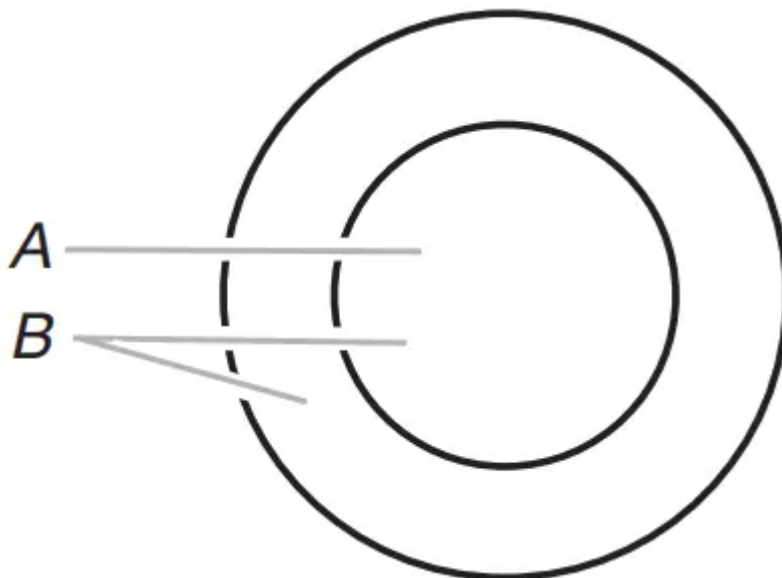

- A. Single size
- B. Dual size

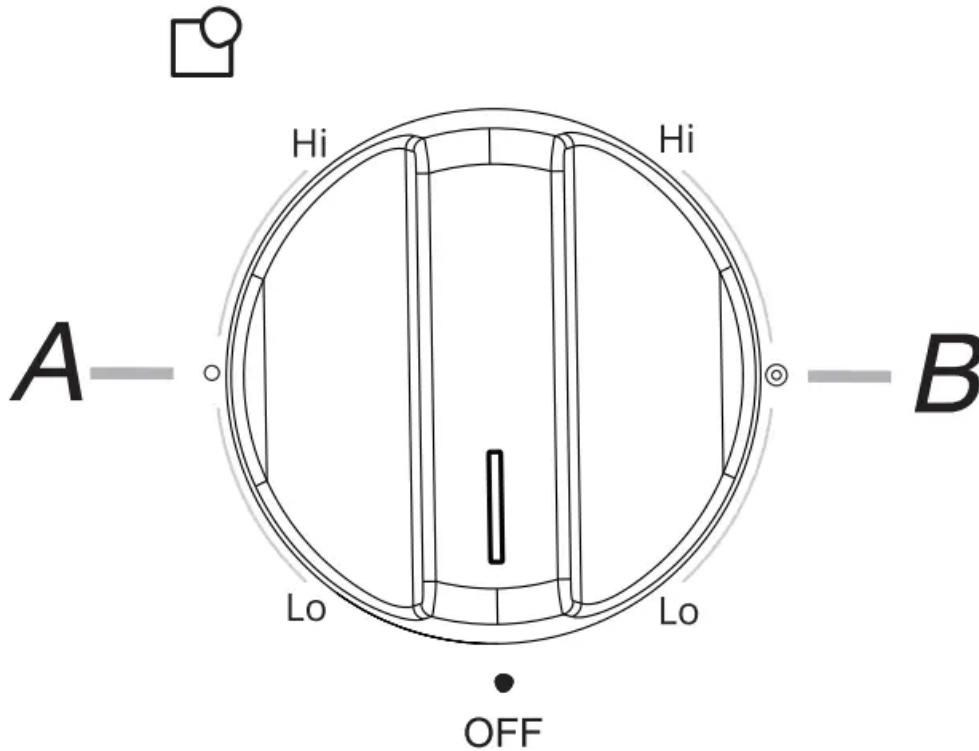

- A. Single zone
- B. Dual zone

To Use SINGLE:

1. Push in and turn knob from the OFF position to the SINGLE zone anywhere between Lo and Hi.
2. Turn knob to OFF when finished.

To Use DUAL and TRIPLE:

1. Push in and turn knob from the OFF position to the DUAL or TRIPLE zone anywhere between Lo and Hi.
2. Turn knob to OFF when finished.

Warm Zone Element (on some models)

WARNING

Food Poisoning Hazard Do not let food sit for more than one hour before or after cooking. Doing so can result in food poisoning or sickness.

The Warm Zone feature can be used to keep cooked foods warm. One hour is the recommended maximum time to maintain food quality.

Do not use it to heat cold foods.

When the Keep Warm function is in use, it will not glow red like the cooking zones, but the indicator light will glow on the control panel.

The Warm Zone feature can be used alone or when any of the other surface cooking areas are being used.

The Warm Zone Element area will not glow red when cycling on. However, the hot surface indicator light will glow as long as the Warm Zone Element area is too hot to touch.

- Use only cookware and dishes recommended for oven and cooktop use.
- Cover all foods with a lid or aluminum foil. When warming baked goods, allow a small opening in the cover for moisture to escape.
- Do not use plastic wrap to cover food. Plastic wrap may melt.
- Use pot holders or oven mitts to remove food.

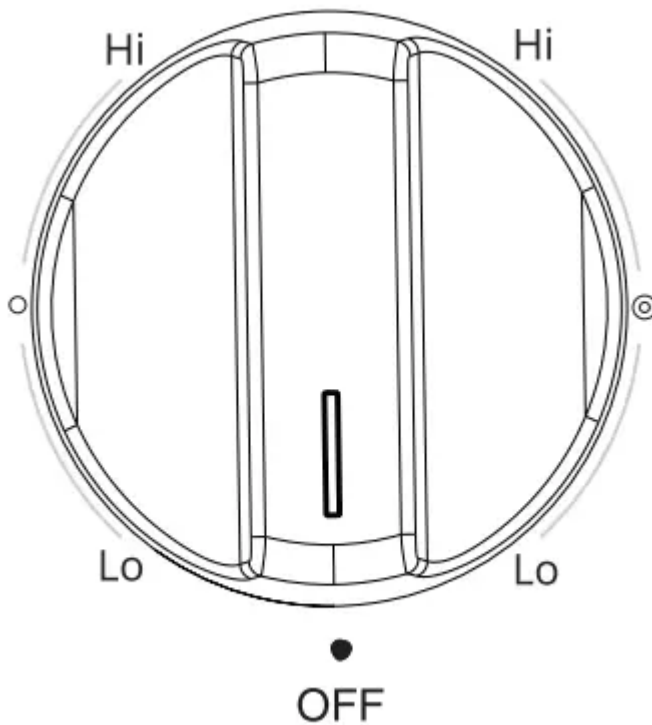

To Use:

1. Push in and turn Warm Zone knob to ON.
2. Turn knob to OFF when finished.

COOKTOP USE

Ceramic Glass (on some models)

The surface cooking area will glow red when an element is on. Some parts of the surface cooking area may not glow red when an element is on. This is normal operation. The burner will cycle on and off to maintain the selected heat level. It will also randomly cycle off and back on again, even while on High, to keep the cooktop from extreme temperatures.

It is normal for the surface of light colored ceramic glass to appear to change color when surface cooking areas are hot. As the glass cools, it will return to its original color.

Cleaning off the cooktop before and after each use will help keep it free from stains and provide the most even heating. On cooktops with light colored ceramic glass, soils and stains may be more visible, and may require more cleaning and attention. Cooktop cleaner and a cooktop scraper are recommended. For more information, see “General Cleaning” section.

- Avoid storing jars or cans above the cooktop. Dropping a heavy or hard object onto the cooktop could crack the cooktop.
- To avoid damage to the cooktop, do not leave a hot lid on the cooktop. As the cooktop cools, air can become trapped between the lid and the cooktop, and the ceramic glass could break when the lid is removed.
- For foods containing sugar in any form, clean up all spills and soils as soon as possible. Allow the cooktop to cool down slightly. Then, while wearing oven mitts, remove the spills using a scraper while the surface is still warm. If sugary spills are allowed to cool down, they can adhere to the cooktop and can cause pitting and permanent marks.
- To avoid scratches, do not slide cookware or bakeware across the cooktop. Aluminum or copper bottoms and rough finishes on cookware or bakeware could leave scratches or marks on the cooktop.
- Do not cook popcorn in prepackaged aluminum containers on the cooktop. They could leave aluminum marks that cannot be removed completely.
- To avoid damage to the cooktop, do not allow objects that could melt, such as plastic or aluminum foil, to touch any part of the entire cooktop.
- To avoid damage to the cooktop, do not use the cooktop as a cutting board.
- Use cookware about the same size as the surface cooking area. Cookware should not extend more than ½” (1.3 cm) outside the area.

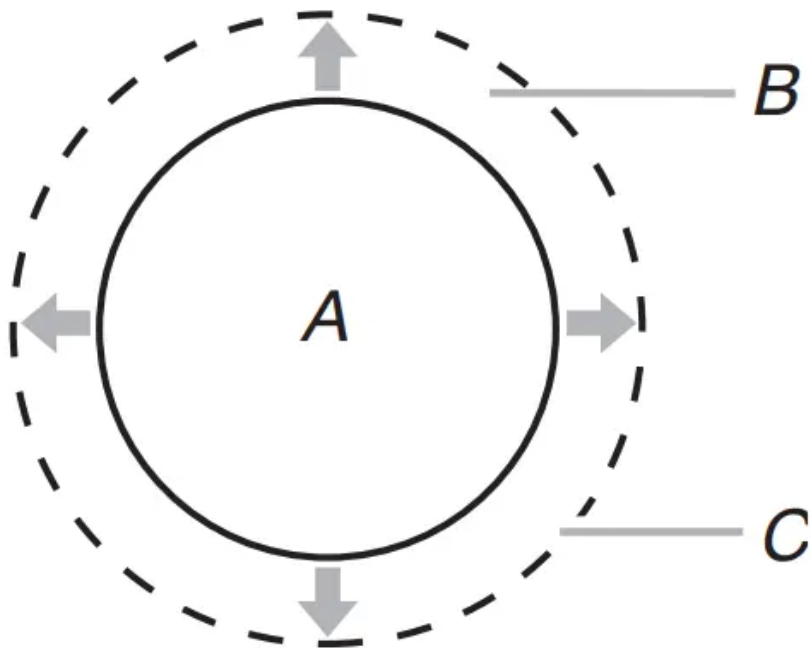

A. Surface cooking area

B. Cookware/canner

C. 1/2" (1.3 cm) maximum overhang

- Use flat-bottomed cookware for best heat conduction and energy efficiency. Cookware with rounded, warped, ribbed or dented bottoms could cause uneven heating and poor cooking results.
- Determine flatness by placing the straight edge of a ruler across the bottom of the cookware. While you rotate the ruler, no space or light should be visible between it and the cookware.
- Cookware designed with slightly indented bottoms or small expansion channels can be used.
- Make sure the bottoms of pots and pans are clean and dry before using them. Residue and water can leave deposits when heated.
- To avoid damage to the cooktop, do not cook foods directly on the cooktop.

Home Canning

When canning for long periods, alternate the use of surface cooking areas, elements or surface burners between batches. This allows time for the most recently used areas to cool.

- Center the canner on the grate or largest surface cooking area or element. On electric cooktops, canners should not extend more than 1/2" (1.3 cm) beyond the surface cooking area or element.

- Do not place canner on 2 surface cooking areas, elements or surface burners at the same time.
- On ceramic glass models, use only flat-bottomed canners.
- On coil element models, the installation of a Canning Unit Kit is recommended. If a kit is not installed, the life of the coil element will be shortened. See “Assistance or Service” for instructions on how to order.
- For more information, contact your local agricultural department. Companies that manufacture home canning products can also offer assistance.

Cookware

IMPORTANT: Do not leave empty cookware on a hot surface cooking area, element or surface burner.

Ideal cookware should have a flat bottom, straight sides, and a well-fitting lid and the material should be of medium-to-heavy thickness.

Rough finishes may scratch the cooktop. Aluminum and copper may be used as a core or base in cookware. However, when used as a base they can leave permanent marks on the cooktop or grates.

Cookware material is a factor in how quickly and evenly heat is transferred, which affects cooking results. A nonstick finish has the same characteristics as its base material.

For example, aluminum cookware with a nonstick finish will take on the properties of aluminum.

Use the following chart as a guide for cookware material characteristics.

Cookware	Characteristics
Aluminum	<ul style="list-style-type: none"> ■ Heats quickly and evenly. ■ Suitable for all types of cooking. ■ Medium or heavy thickness is best for most cooking tasks.
Cast iron	<ul style="list-style-type: none"> ■ Heats slowly and evenly. ■ Good for browning and frying. ■ Maintains heat for slow cooking.
Ceramic or Ceramic glass	<ul style="list-style-type: none"> ■ Follow manufacturer's instructions. ■ Heats slowly, but unevenly. ■ Ideal results on low to medium heat settings.
Medium Low	<ul style="list-style-type: none"> ■ Stew or steam food. ■ Simmer.
Copper	<ul style="list-style-type: none"> ■ Heats very quickly and evenly.
Porcelain enamelsteel or cast iron	<ul style="list-style-type: none"> ■ See stainless steel or cast iron.
Stainless steel	<ul style="list-style-type: none"> ■ Heats quickly, but unevenly. ■ A core or base of aluminum or copper on stainless steel provides even heating.

COOKTOP CARE

General Cleaning

IMPORTANT: Before cleaning, make sure all controls are off and the cooktop is cool. Always follow label instructions on cleaning products.

Soap, water and a soft cloth or sponge are suggested first unless otherwise noted. When cleaning the cooktop with electronic controls, lock the controls. See "Control Lock" section.

Do not use a steam cleaner.

STAINLESS STEEL (on some models)

To avoid damage to stainless steel surfaces, do not use soapfilled scouring pads, abrasive cleaners, Cooktop Cleaner, steelwool pads, gritty washcloths or abrasive paper towels.

Cleaning Method:



Rub in direction of grain to avoid damaging.

- Affresh® Stainless Steel Cleaner and Polish (Part Number W10355016B) (not included): See “Assistance or Service” section to order.
- All-purpose cleaner: Rinse with clean water and dry with soft, lint-free cloth.
- Vinegar for hard water spots.

COOKTOP CONTROLS

To avoid damage to the cooktop controls, do not use steel wool, abrasive cleansers or oven cleaner.

To avoid damage, do not soak knobs.

When replacing knobs, make sure knobs are in the Off position.

Do not remove seals under knobs.

Cleaning Method:

- Soap and water: Pull knobs straight away from control panel to remove.
- Do not place knobs in dishwasher.

CERAMIC GLASS

To avoid damage to the cooktop, do not use steel wool, abrasive powder cleansers, chlorine bleach, rust remover or ammonia.

Cleaning Method:

Always wipe with a clean, wet cloth or sponge and dry thoroughly to avoid streaking and staining.

Affresh® Cooktop Cleaner (Part Number W10355051B) is recommended for regular use to help avoid scratches, pitting and abrasions, and to condition the cooktop. It may be ordered as an accessory. See “Assistance or Service” section to order.

Cooktop Scraper is also recommended for stubborn soils, and can be ordered as an accessory. See “Assistance or Service” section to order. The Cooktop Scraper uses razor blades. Store razor blades out of the reach of children.

Light to moderate soil

- Paper towels or clean damp sponge: Clean while the cooktop is still warm. You may want to wear oven mitts while doing so.

Sugary spills (jellies, candy, syrup)

- **Cooktop Scraper:** Clean while the cooktop is still warm. You may want to wear oven mitts while doing so.

- **Affresh® Cooktop Cleaner and clean damp paper towel:** Clean as soon as cooktop has cooled down. Rub creme into surface with a damp paper towel or soft cloth. Continue rubbing until white film disappears.

Heavy soil, dark streaks, specks and discoloration

- Affresh® Cooktop Cleaner or nonabrasive cleanser: Rub product into soil with a damp paper towel or soft cloth. Continue rubbing until white film disappears.

Burned-on soil

- Affresh® Cooktop Cleaner and Cooktop Scraper: Rub creme into soil with damp paper towel. Hold scraper as flat as possible on surface and scrape. Repeat for stubborn spots. Polish entire cooktop with creme and paper towel.

Metal marks from aluminum and copper

- Affresh® Cooktop Cleaner: Clean as soon as cooktop has cooled down. Rub creme into surface with a damp paper towel or soft cloth. Continue rubbing until white film disappears. The marks will not totally disappear but after many cleanings become less noticeable.

Tiny scratches and abrasions

- Affresh® Cooktop Cleaner: Rub creme into surface with a damp paper towel or soft cloth. Continue rubbing until white film disappears. Scratches and abrasions do not affect cooking performance and after many cleanings become less noticeable.

Do not use steel wool, abrasive powder cleansers, chlorine bleach, rust remover or ammonia because damage may occur.

TROUBLESHOOTING



Problem	Possible Causes and/or Solutions
<p>Nothing will operate</p>	<p>A household fuse has blown or a circuit breaker has tripped: Replace the fuse or reset the circuit breaker. If the problem continues, call an electrician.</p> <p>Cooktop isn't wired properly: See the Installation Instructions.</p>
<p>Cooktop will not operate</p>	<p>Control knob set incorrectly: Push in knob before turning to a setting.</p> <p>One or more burners stopped working during use: Allow the cooktop to cool down for 30 minutes, then turn the burner on again.</p> <p>Control Lock is not set: Press and hold "Control Lock" for 3 seconds</p>
<p>Excessive heat around cookware on cooktop</p>	<p>Cookware is not the proper size: Use cookware about the same size as the surface cooking area, element, or surface burner. Cookware should not extend more than ½" (1.3 cm) outside the cooking area.</p> <p>Cooktop surfaces become hot: When cooktop is in use, the entire cooktop area may become hot.</p>
<p>Cooktop cooking results not what expected</p>	<p>Proper cookware is not being used: See the "Cookware" section.</p> <p>Control knob is not set to the proper heat level: See the "Cooktop Controls" section.</p> <p>Cooktop is not level: Level the cooktop. See the Installation Instructions.</p> <p>Certain power levels seem to take longer to cook food or some power levels do not perform as well as usual: The cooktop regulates the temperature of the internal components and automatically reduces the power of all the elements in use without any visual or audible feedback. Allow the cooktop to cool down for 30 minutes to resume normal cooking performance. See "To Use" in the "Cooktop Controls" section.</p>
<p>Cooktop is beeping</p>	<p>Key is pressed and held: Remove any objects left on the control area, or wipe any debris from the control panel surface. If the cooktop continues beeping for longer than 15 minutes, the control</p>



	panel will lock, and the F2E1 code will appear in the display. See “Cooktop is displaying F2E1 code” in this section.
Cooktop is displaying F2E1 code	<p>Cooktop is displaying F2E1, indicating that one or more keys are permanently pressed: Follow the steps below.</p> <ol style="list-style-type: none">1. Make sure the cooktop controls are off.2. Clean the cooktop touch control panel thoroughly. See the “General Cleaning” section.3. Disconnect power or unplug the cooktop.4. After 1 minute, reconnect power or plug in the cooktop.5. If error returns after 1 minute, call for service.

Warning

This content is compiled from multiple sources and is provided for reference purposes only. It may not be complete or fully applicable to all situations. If you are unable to resolve your issue, please contact the product manufacturer or an authorized service provider for official support.