

Description

General Description

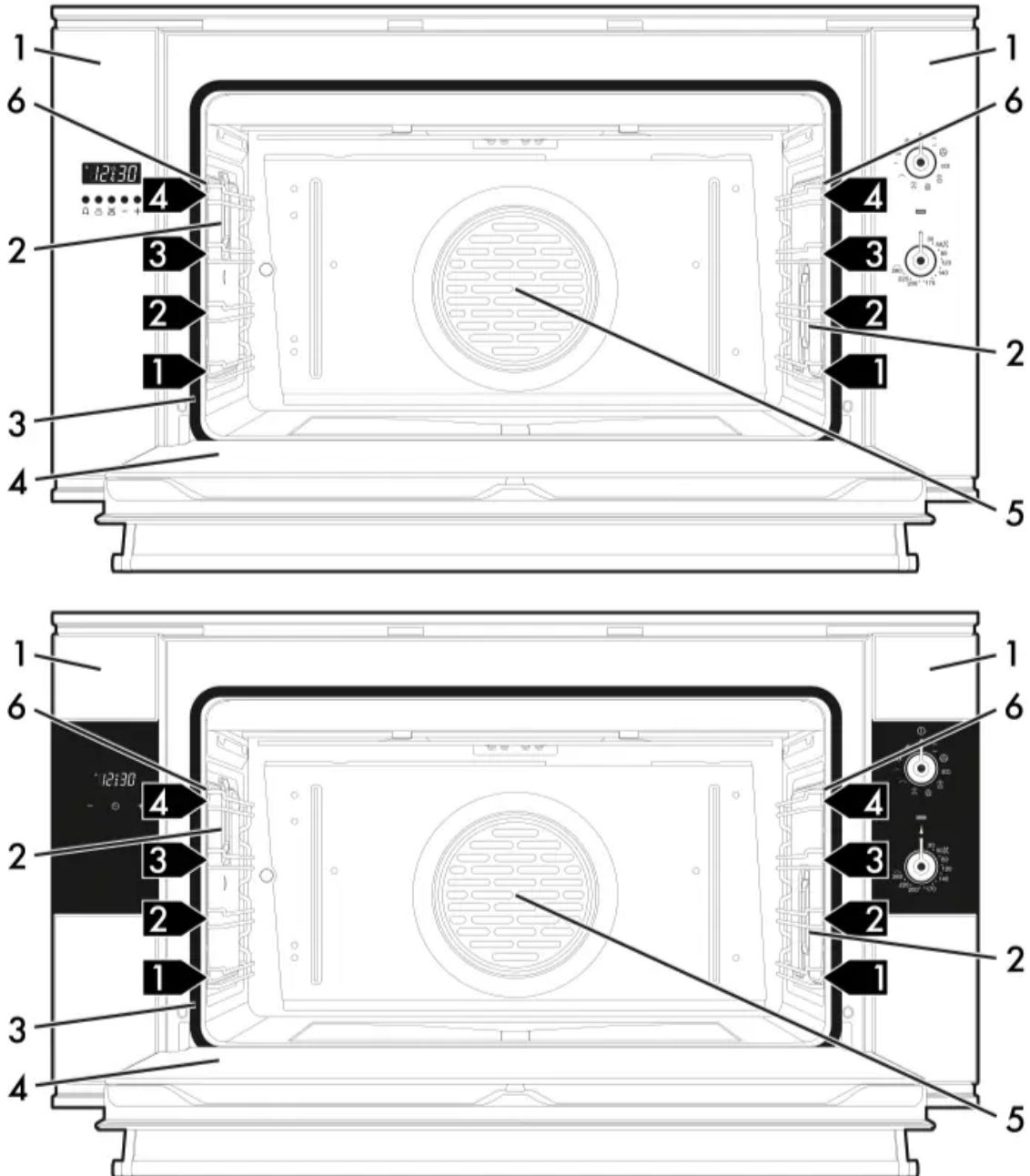

1 Control panel

2 Oven light

3 Seal

4 Door



5 Fan

6 Rack/tray support frames

1,2,3...

Frame shelf

Control panel

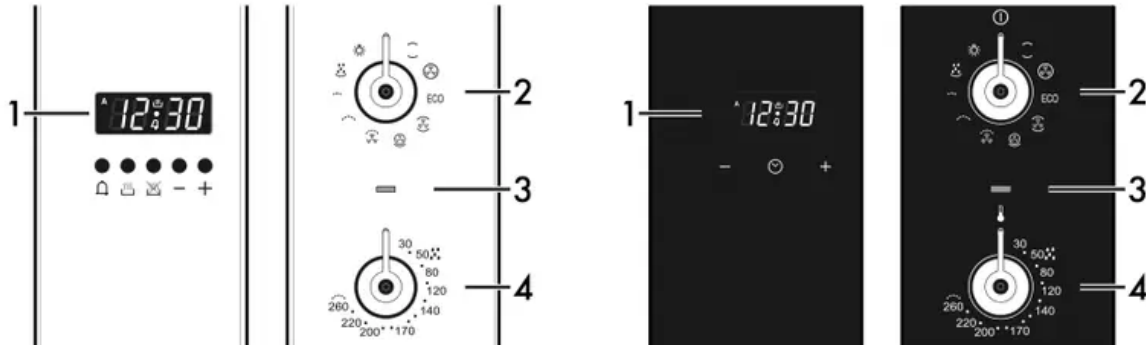

1. Programmer clock

Useful for displaying the current time, setting programmed cooking operations and programming the minute minder timer.

2. Function knob

The oven's various functions are suitable for different cooking methods. After selecting the required function, set the cooking temperature using the temperature knob.

3. Thermostat indicator light

The indicator light comes on to indicate that the oven is heating up. It turns off as soon as it reaches the set temperature. It flashes regularly to indicate that the temperature set inside the oven is kept constant.

4. Temperature knob

This knob allows you to select the cooking temperature.

Turn the knob clockwise to the required value, between the minimum and maximum setting.

Other parts

Shelves

The appliance features shelves for positioning trays and racks at different heights. The insertion heights are indicated from the bottom upwards (see 2.1 General Description).

Cooling fan

The fan cools the oven and comes into operation during cooking.

The fan causes a steady outflow of air from above the door which may continue even after the appliance has been turned off.

Interior lighting

The oven light comes on when any function is selected.

Available accessories



Some models are not provided with all accessories.

Rack

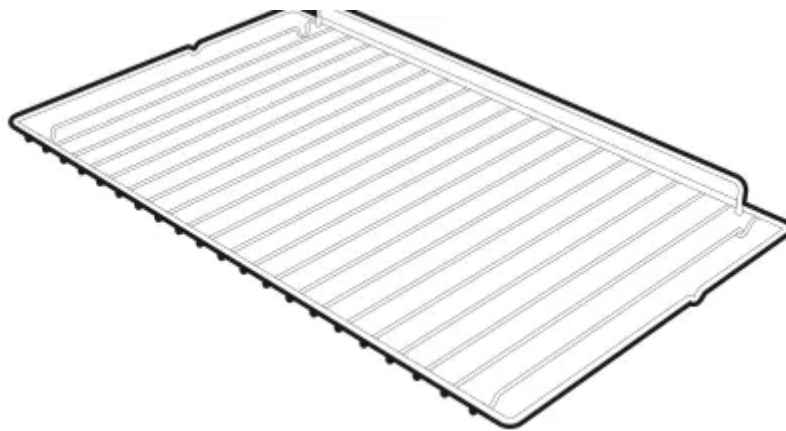

Useful for supporting containers with food during cooking.

Tray rack

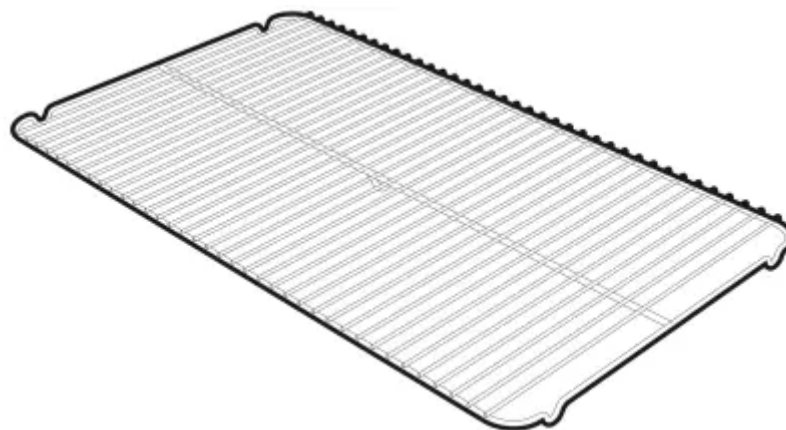

To be placed over the top of the oven tray; for cooking foods which may drip.

Oven tray

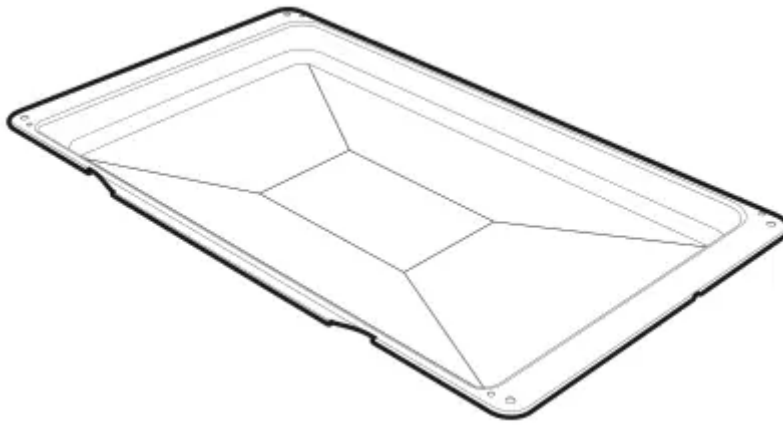

Useful for collecting fat from foods placed on the rack above.



The oven accessories intended to come into contact with food are made of materials that comply with the provisions of current legislation.



Original supplied and optional accessories can be requested to Authorised Assistance Centres. Use only original accessories supplied by the manufacturer.

Use

Instructions



High temperature inside the oven during use

Danger of burns

- Keep the oven door closed during cooking.
- Protect your hands wearing heat resistant gloves when moving food inside the oven.
- Do not touch the heating elements inside the oven.
- Do not pour water directly onto very hot trays.
- Do not allow children to get near the oven when it is in operation.



High temperature inside the oven during use

Danger of fire or explosion

- Do not spray any spray products near the oven.
- Do not use or leave flammable materials near the oven.
- Do not use plastic kitchenware or containers when cooking food.
- Do not put sealed tins or containers in the oven.
- Do not leave the oven unattended during cooking operations where fats or oils could be released.
- Remove all trays and racks which are not required during cooking.



Improper use

Risk of damage to enamelled surfaces

- Do not cover the bottom of the oven cavity with aluminium or tin foil sheets.
- If you wish to use greaseproof paper, place it so that it will not interfere with the hot air circulation inside the oven.
- Do not place pans or trays directly on the bottom of the oven cavity.
- Do not pour water directly onto very hot trays.

First use

1. Remove any protective film from the outside or inside of the appliance, including accessories.
2. Remove any labels (apart from the technical data plate) from the accessories and from the oven cavity.
3. Remove and wash all appliance accessories (see 4 Cleaning and maintenance).
4. Heat the empty oven at the maximum temperature to burn off any residues left by the manufacturing process.

Using the accessories

Racks and trays

Racks and trays have to be inserted into the side guides until they come to a complete stop.

- The mechanical safety locks that prevent the rack from being taken out accidentally have to face downwards and towards the oven back.

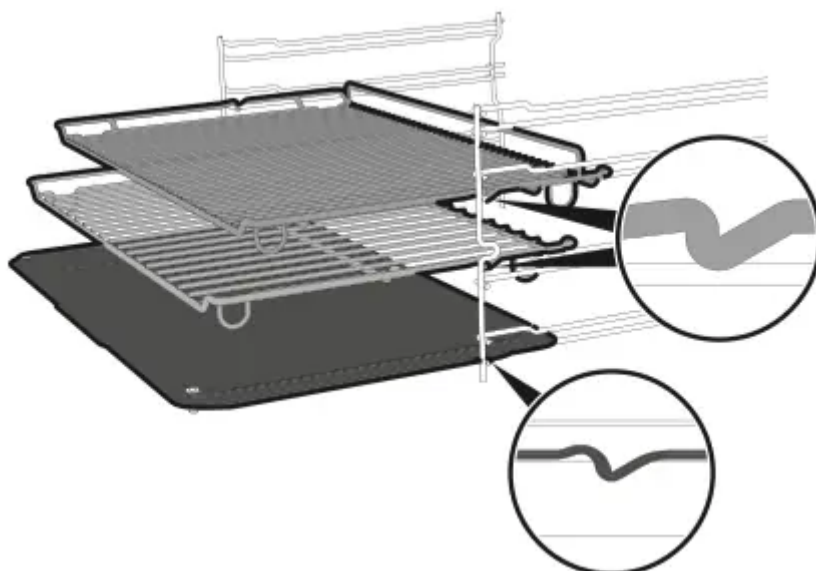

Gently insert racks and trays into the oven until they come to a stop.



Clean the trays before using them for the first time to remove any residues left by the manufacturing process.

Tray rack

The tray rack has to be inserted into the tray. In this way fat can be collected separately from the food which is being cooked.

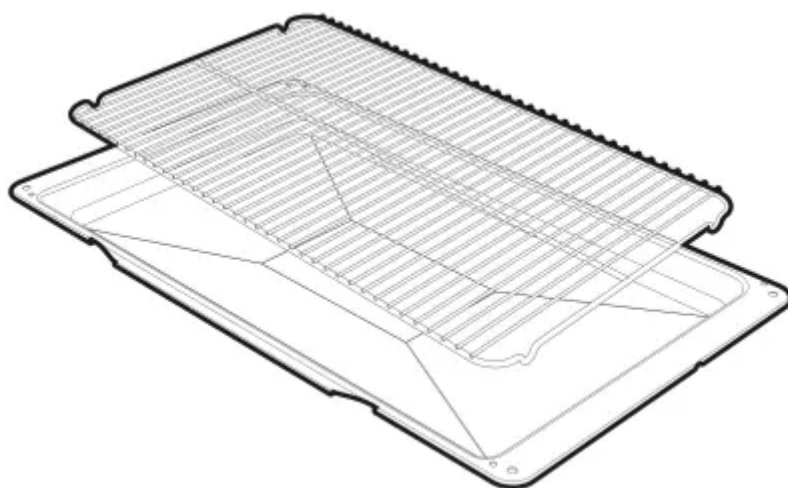

Using the oven

Switching on the oven

To switch on the oven:

1. Select the cooking function using the function knob.
2. Select the temperature using the temperature knob.



Regular flashing of the thermostat indicator light during cooking is normal and indicates that the temperature is being maintained constant inside the oven.



Grilling processes must never last more than 60 minutes.

Functions list



Static

As the heat comes from above and below at the same time, this system is particularly suitable for certain types of food. Traditional cooking, also known as static cooking, is suitable for cooking just one dish at a time. Perfect for all types of roasts, bread and cakes and in any case particularly suitable for fatty meats such as goose and duck.



Fan with circulaire

The combination of the fan and the circulaire heating element (incorporated in the rear of the oven) allows you to cook different foods on several levels, as long as they need the same temperatures and same type of cooking. Hot air circulation ensures instant and even distribution of heat. It will be possible, for instance, to cook fish, vegetables and biscuits simultaneously (on different levels) without odours and flavours mingling.



Eco

Using the grill and the lower heating element in combination is particularly suitable for cooking on a single shelf, as it provides low energy consumption. Ideal for cooking meat, fish and vegetables. Not recommended for desserts which must rise.



Fan assisted (on some models only)

The operation of the fan, combined with traditional cooking, ensures consistent cooking even with complex recipes. Perfect for biscuits and cakes, even when simultaneously cooked on several levels. (For multiple-level cooking, we recommend using the 2nd and 4 th shelves).



Lower element + fan with circulaire

Fan-assisted cooking is combined with the heat coming from the bottom and allows you at the same time to slightly brown food. Perfect for any type of food



Fan with grill

The air produced by the fan softens the strong heatwave generated by the grill, grilling perfectly even very thick foods. Perfect for large cuts of meat (e.g. shin of pork).



Grill

The heat coming from the grill element gives perfect grilling results above all for thin and medium thickness meat and in combination with the rotisserie (where fitted) gives the food an even browning at the end of cooking. Perfect for sausages, spare ribs and bacon. This function enables large quantities of food, particularly meat, to be grilled evenly.

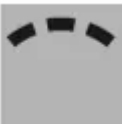

Small grill (on some models only)

Using only the heat released from the central element, this function allows you to grill small portions of meat and fish for making kebabs, toasted sandwiches and any types of grilled vegetable side dishes.



Lower element

The heat coming just from the bottom allows you to complete the cooking of foods that require a higher bottom temperature, without affecting their browning. Perfect for cakes, pies, tarts and pizzas.



Light

In this position the oven light can be turned on during normal operations.



Vapor Clean

This function makes cleaning easier using the steam produced by a small quantity of water poured into a tray on the first shelf level.

Cooking advice

General advice

- Use a fan assisted function to achieve consistent cooking at several levels.
- It is not possible to shorten cooking times by increasing the temperature (the food could be overcooked on the outside and undercooked on the inside).

Advice for cooking meat

- Cooking times vary according to the thickness and quality of the food and to consumer taste.
- Use a meat thermometer when roasting meat, or simply press on the roast with a spoon. If it is hard, it is ready; If not, it needs another few minutes cooking.

Advice for cooking with the Grill and the Fan with grill

- Meat can be grilled even when it is put into the cold oven or into the preheated oven if you wish to change the effect of the cooking.
- With the Fan with grill function, we recommend that you preheat the oven before grilling.
- We recommend placing the food at the centre of the rack.
- With the Grill function, we recommend that you turn the temperature knob to the maximum value near the  symbol to optimise cooking.

Advice for cooking desserts/pastries and biscuits

- Use dark metal moulds: They help to absorb the heat better.
- The temperature and the cooking time depend on the quality and consistency of the dough.
- To check whether the dessert is cooked right through: At the end of the cooking time, put a toothpick into the highest point of the dessert. If the dough does not stick to the toothpick, the dessert is cooked.
- If the dessert collapses when it comes out of the oven, on the next occasion reduce the set temperature by about 10°C, selecting a longer cooking time if necessary.

Advice for defrosting and proving

- Place frozen foods without their packaging in a lidless container on the first shelf of the oven.
- Avoid overlapping the food.
- To defrost meat, use the rack placed on the second level and a tray on the first level. In this way, the liquid from the defrosting food drains away from the food.
- The most delicate parts can be covered with aluminium foil.
- For successful proving, a container of water should be placed in the bottom of the oven.

To save energy

- Stop cooking a few minutes before the time normally used. Cooking will continue for the remaining minutes with the heat which has accumulated inside the oven.
- Reduce any opening of the door to a minimum to avoid heat dispersal.
- Keep the inside of the appliance clean at all times.

Programmer clock (on some models only)

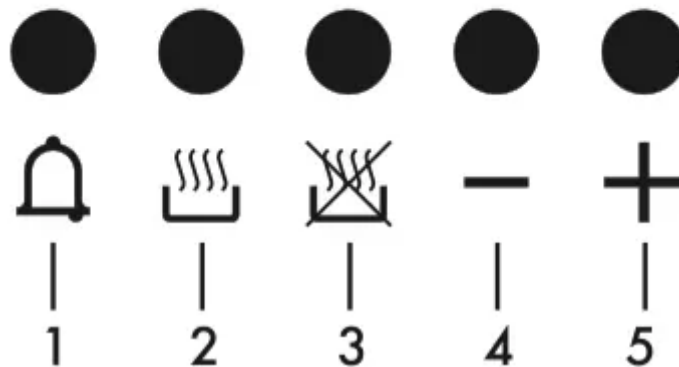

1 Minute minder timer key

2 Cooking duration key







3 End of cooking key

4 Value decrease key

5 Value increase key

Setting the time

On the first use, or after a power failure, the digits  will be flashing on the appliance's display.

1. Press the  and  keys at the same time. The dot between the hours and the minutes flashes.
2. The time can be set using  or . Keep the key pressed in to increase or decrease rapidly.
3. Press the  key or wait 5 seconds. The dot between the hours and the minutes stops flashing.
4. The symbol  on the display indicates that the appliance is ready to start cooking.





If no time is set, it will not be possible to use the appliance.



Timed cooking



Timed cooking is the function which allows a cooking operation to be started and then ended after a specific length of time set by the user.

1. After selecting a cooking function and temperature, wait for the oven to preheat.

2. Press . The display will show the digits  and the symbol  displayed between the hours and the minutes.

3. Use the  or  key to set the required minutes.

4. Wait approx. 5 seconds without pressing any key in order for the function to activate. The



current time and the symbols  and  will appear on the display.

5. At the end of cooking the heating elements will be deactivated. On the display, symbol



turns off, symbol  flashes and the buzzer sounds.

6. To turn off the buzzer just press any key of the programmer clock.

7. Press keys  and  at the same time to reset the programmer clock.





It is not possible to set a cooking time of more than 10 hours.



After the setting, to display the cooking time left press the  key



To reset the set program, press keys  and  at the same time and switch off the oven manually.



Programmed cooking



Programmed cooking is the function which allows a cooking operation to be started at a set time and then ended after a specific length of time set by the user.

1. Set the cooking time as described in the previous point “Timed cooking”.



2. Press . The sum of the current time plus the pre-set cooking duration will appear on the display.

3. Use the  or  key to set the required minutes.



4. Wait approx. 5 seconds without pressing any key in order for the function to activate. The

current time and the symbols  and  will appear on the display.

5. At the end of cooking the heating elements will be deactivated. On the display, symbol

 turns off, symbol  flashes and the buzzer sounds. Programmed cooking is the function which allows a cooking operation to be started at a set time and then ended after a specific length of time set by the user.

6. To turn off the buzzer just press any key of the programmer clock.

7. Press keys  and  at the same time to reset the programmer clock.



After the setting, to display the cooking time left press the  key. To display the







end of cooking time, press the  key.

Minute minder timer



The minute minder timer does not stop the cooking operation but rather informs the user when the set time has run out.

The minute minder timer can be activated at any time.

1. Press . The display shows the digits  and the indicator light  flashing between the hours and the minutes.
2. Use the  or  key to set the required minutes.
3. Wait approx. 5 seconds without pressing any key to finish setting the minute minder. The current time and the symbols  and  appear on the display.



It is not possible to set a cooking time of more than 24 hours.





After the minute minder timer has been programmed, the display will go back to showing the current time; to display the remaining time, press 

Adjusting the buzzer volume

The buzzer volume can be set to 3 different levels. When the buzzer is in operation, press  to change the setting.

Deleting the set data

Press keys  and  at the same time to reset the programs set.

Then switch off the oven manually if cooking is in progress.

“Touch” Programmer clock (on some models only)

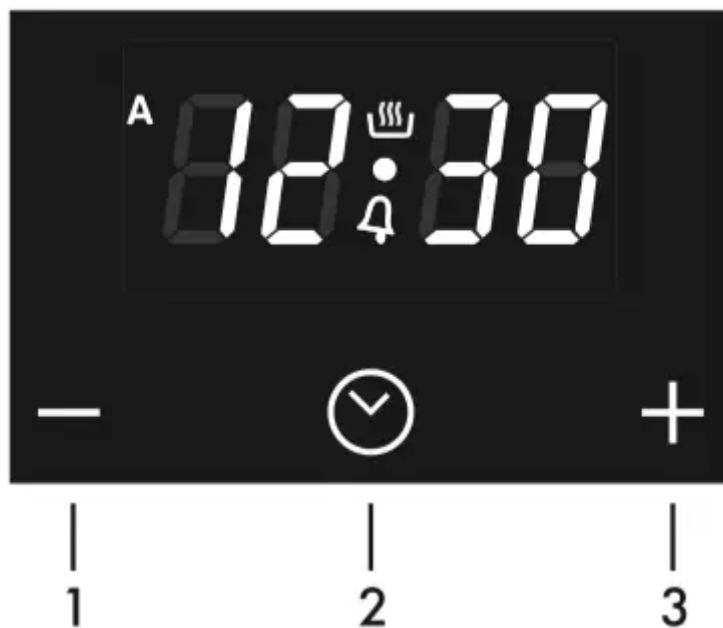







1 Decrease key

2 Menu key

3 Increase key

Setting the time

On the first use, or after a power failure, the digits  and symbol  will be flashing on the appliance's display.

1. Hold the menu key  down for around 2 seconds. The dot between the hours and the minutes will start flashing.
2. The time can be set using  or . Keep the key pressed in to increase or decrease rapidly. The time set will be stored after around 7 seconds from the last modification.
3. If you need to make further changes to the current time, hold the  and  keys down for around 2 seconds. When the dot between the hours and the minutes starts flashing, it is possible to change the current time.
4. The symbol  on the display indicates that the appliance is ready to start cooking.



If no time is set, it will not be possible to use the appliance.





Timed cooking





Timed cooking is the function which allows a cooking operation to be started and then ended after a specific length of time set by the user.



1. After selecting a cooking function and temperature, wait for the oven to preheat.

2. Hold the menu key  seconds.

3. Press the menu key  again. The display will show the digits  and the text  in sequence, while the in sequence,  symbol flashes.

4. Use the  or  key to set the required minutes.

5. Wait approx. 7 seconds without pressing any key in order for the function to activate. The



current time will appear on the display, together with the symbols  and .

6. At the end of cooking the heating elements will be deactivated. On the display, symbol

 turns off, symbol  flashes and the buzzer sounds.

7. Return the function and temperature knobs to 0.

8. To turn off the buzzer just press any key of the programmer clock.

9. Press keys  and  at the same time to reset the set program.





It is not possible to set a cooking time of more than 10 hours.



It is not possible to set a programmed cooking time of more than 24 hours.



After setting, hold the menu key  down for 2 seconds to display the cooking time

remaining. Press the menu key  again. The display shows the text  and the remaining cooking time in sequence.

Cooking information table

| Food | Weight (Kg) | Function | Runner position from the bottom | Temperature (°C) | Time (minutes) | |
|-----------------------|-------------|--------------------|---------------------------------|------------------|-------------------------|-------------------------|
| Lasagne | 3 - 4 | Static | 1 | 220 - 230 | 50 - 60 | |
| Pasta bake | 2 | Static | 1 | 220 - 230 | 40 | |
| Roast veal | 1.2 | Fan assisted | 2 | 180 - 190 | 70 - 80 | |
| Pork loin | 1.2 | Fan assisted | 2 | 180 - 190 | 70 - 80 | |
| Pork shoulder | 1.2 | Fan assisted | 2 | 180 - 190 | 90 - 100 | |
| Roast rabbit | 1.2 | Fan assisted | 2 | 180 - 190 | 70 - 80 | |
| Turkey breast | 1.5 | Fan assisted | 2 | 180 - 190 | 80 - 90 | |
| Roast pork neck | 2 | Fan assisted | 2 | 180 - 190 | 190 - 210 | |
| Roast chicken | 1.2 | Fan assisted | 2 | 190 - 200 | 60 - 70 | |
| | | | | | 1 st surface | 2 nd surface |
| Pork sausages | 1.2 | Fan with grill | 3 | 260 | 7 - 9 | 5 - 6 |
| Pork chops | 1.2 | Grill | 4 | 260 | 15 | 5 |
| Hamburgers | 0.8 | Grill | 4 | 260 | 9 | 5 |
| Bacon | 0.8 | Fan with grill | 3 | 260 | 13 | 3 |
| Spit-roast chicken | 1.2 | Grill + Rotisserie | | 260 | 70 - 80 | |
| Salmon trout | 1.2 | Lower element | 2 | 150 - 160 | 35 - 40 | |
| Pizza | 1 | Lower element | 1 | 260 | 6 - 10 | |
| Bread | 1 | Fan assisted | 2 | 190 - 200 | 25 - 30 | |
| Focaccia | 1 | Fan assisted | 2 | 180 - 190 | 15 - 20 | |
| Bundt cake | 1 | Fan assisted | 2 | 160 | 50 - 60 | |
| Tart | 1 | Fan assisted | 2 | 160 | 30 - 35 | |
| Short pastry | 0.5 | Lower element | 2 | 160 - 170 | 20 - 25 | |
| Jam tarts | 1.2 | Fan assisted | 2 | 160 - 170 | 40 - 50 | |
| Paradise cake | 1.2 | Fan assisted | 2 | 160 | 50 - 60 | |
| Profiteroles | 0.8 | Fan assisted | 2 | 150 - 160 | 40 - 50 | |
| Sponge cake | 0.8 | Fan assisted | 2 | 150 - 160 | 45 - 50 | |
| Rice pudding | 1 | Static | 2 | 160 | 40 - 50 | |
| Brioche | 0.6 | Fan assisted | 2 | 160 | 25 - 30 | |
| Short pastry biscuits | | Fan assisted | 1-3 | 160 - 170 | 16 - 20 | |

The times indicated in the table do not include preheating times and are provided only as a guide.

Cleaning and maintenance

Instructions



Improper use

Risk of damage to surfaces

- Do not use steam jets to clean the appliance.
- Do not use cleaning products containing chlorine, ammonia or bleach on steel parts or parts with metallic finishes on the surface (e.g. anodizing, nickel- or chromium-plating).
- Do not use abrasive or corrosive detergents on glass parts (e.g. powder products, stain removers and metallic sponges).
- Do not use rough or abrasive materials or sharp metal scrapers.

Cleaning the surfaces

To keep the surfaces in good condition, they should be cleaned regularly after use. Let them cool first.

Ordinary daily cleaning

Always use only specific products that do not contain abrasives or chlorine-based acids.

Pour the product onto a damp cloth and wipe the surface, rinse thoroughly and dry with a soft cloth or a microfibre cloth.

Food stains or residues

Do not use metallic sponges or sharp scrapers as they will damage the surfaces. Use ordinary non-abrasive products with the aid of wooden or plastic utensils if necessary. Rinse thoroughly and dry with a soft cloth or a microfibre cloth.

Do not allow residues of sugary foods (such as jam) to set inside the oven. If left to set for too long, they might damage the enamel lining of the oven.

Removing the door

For easier cleaning, the door can be removed and placed on a canvas.

1. Open the door completely and insert two pins into the holes on the hinges indicated in the figure.

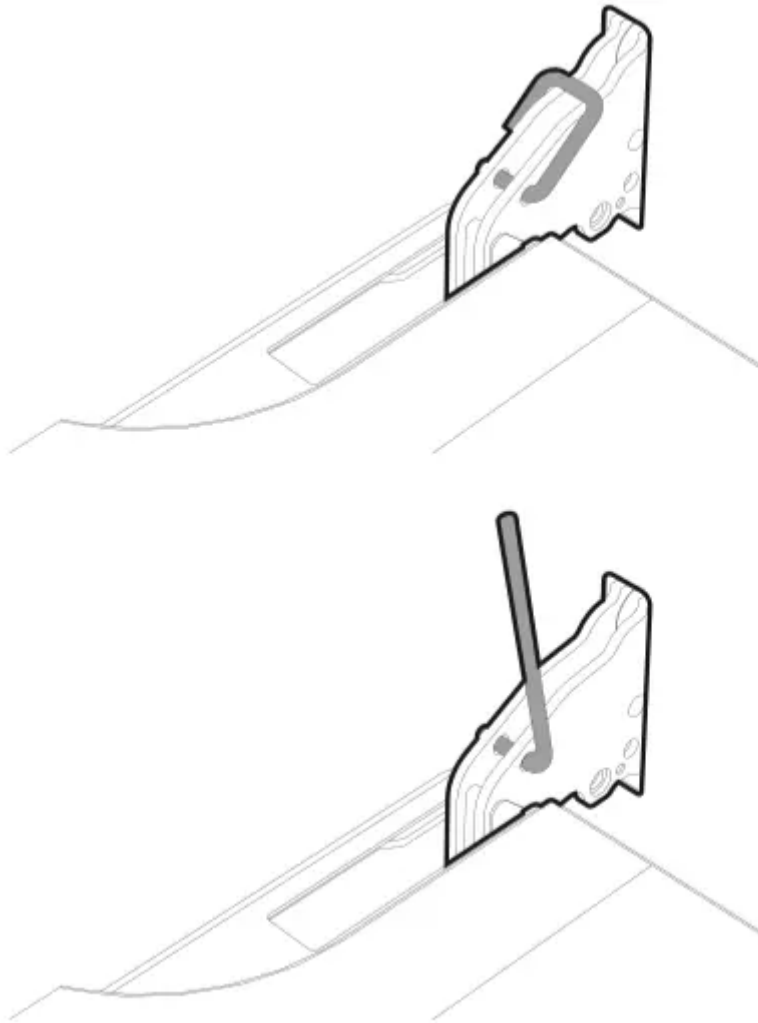

2. Grasp the door on both sides with both hands, lift it forming an angle of around 30° and remove it.

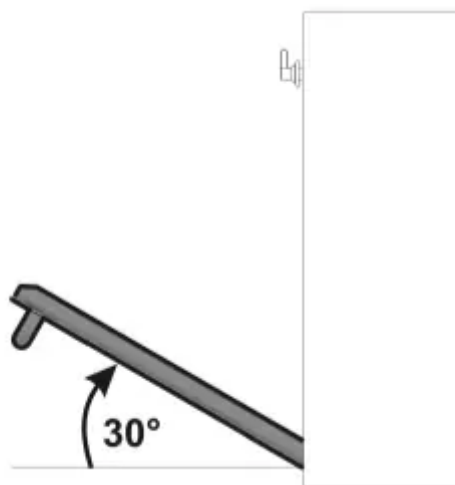

3. To reassemble the door, put the hinges in the relevant slots in the oven, making sure that grooved sections A are resting completely in the slots. Lower the door and once it is in place remove the pins from the holes in the hinges.

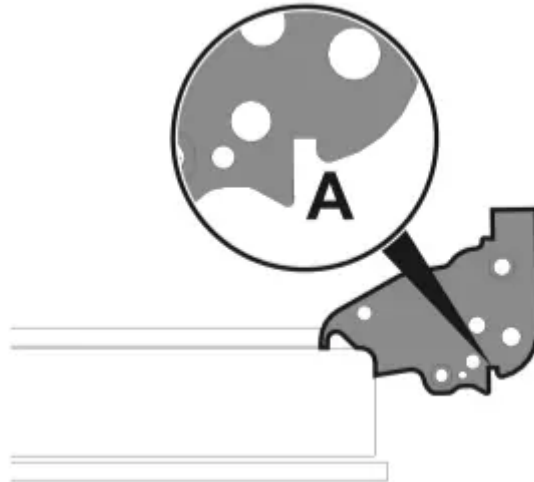

Cleaning the door glazing

The glass in the door should always be kept thoroughly clean. Use absorbent kitchen roll. In case of stubborn dirt, wash with a damp sponge and an ordinary detergent.



We recommend the use of cleaning products distributed by the manufacturer.

Removing the internal glass panes

For easier cleaning the door internal glass panes can be disassembled.

1. Remove the internal glass pane by pulling the rear part gently upwards, following the movement indicated by the arrows (1).
2. Then, pull the front part upwards (2). In this way, the 4 pins attached to the glass detach from their housings in the oven door.

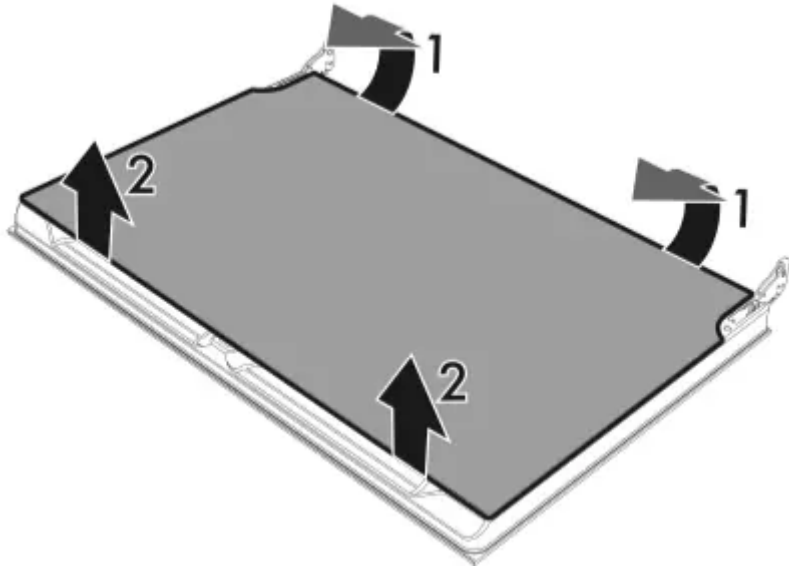

3. Some models have an intermediate glass pane. Remove the intermediate glass pane by lifting it upwards.

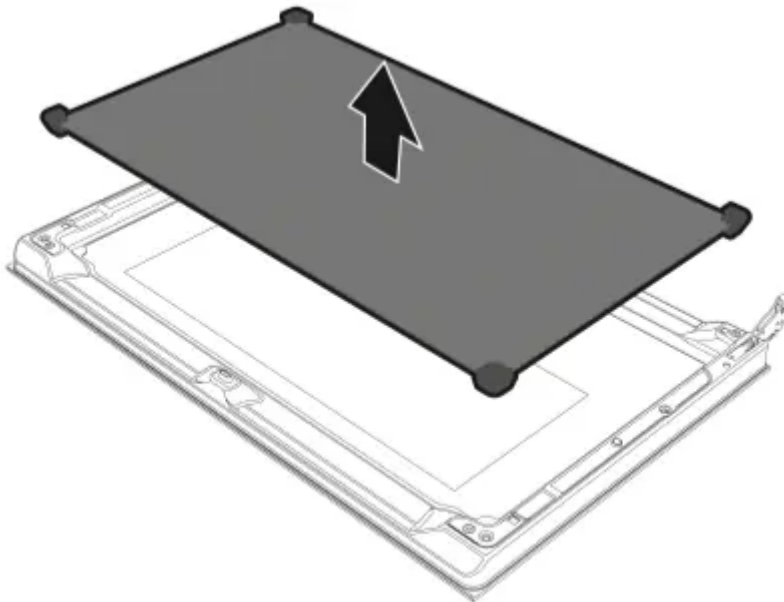

4. Clean the external glass pane and the panes previously removed. Use absorbent kitchen roll. In case of stubborn dirt, wash with a damp sponge and neutral detergent.

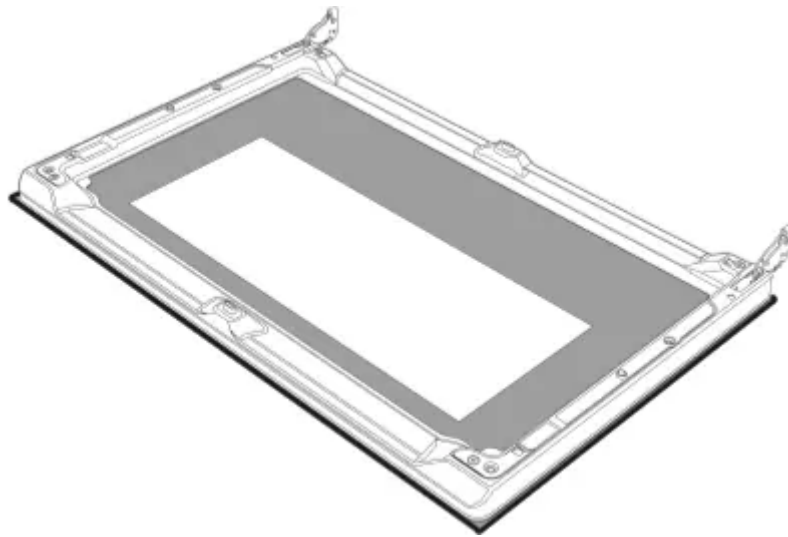

5. Refit the panes in the reverse order in which they were removed.

6. Reposition the internal glass pane. Take care to centre and insert the 4 pins into their housings in the oven door by applying slight pressure.

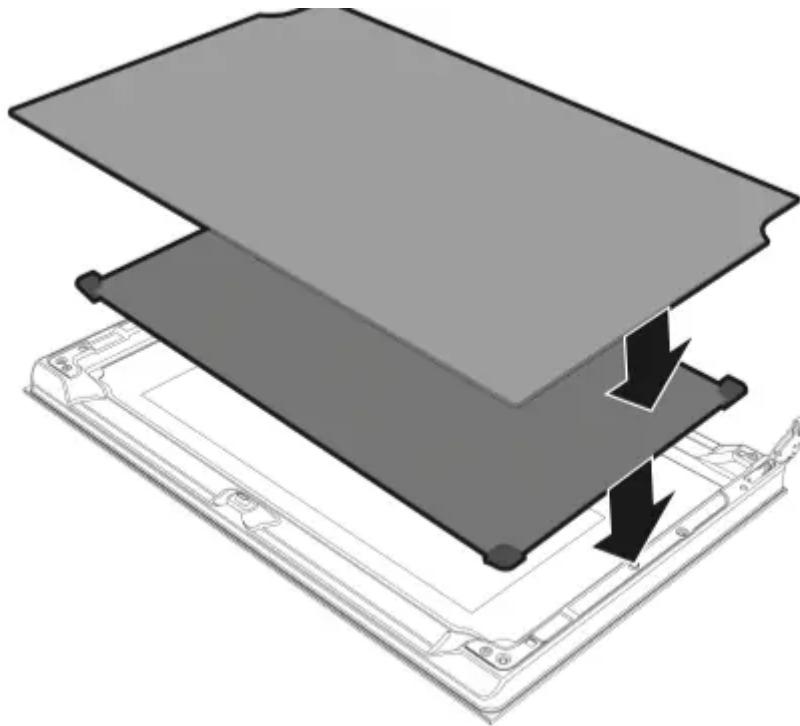

Cleaning the inside of the oven

For the best oven upkeep, clean it regularly after having allowed it to cool.

Take out all removable parts.

Clean the oven racks with warm water and non-abrasive detergent. Carefully rinse and dry damp parts.

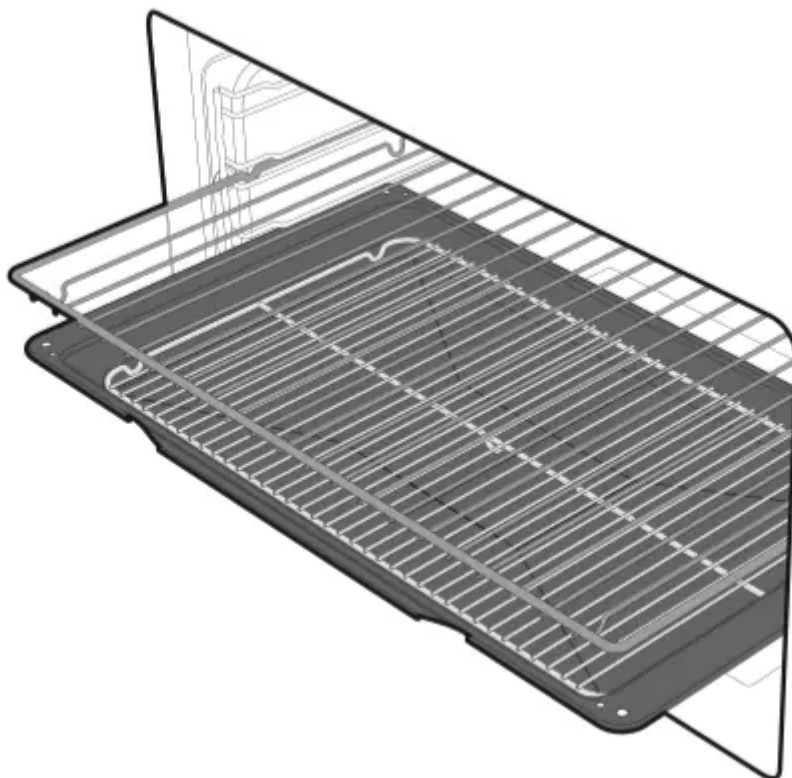

The oven should be operated at the maximum temperature for about 15-20 minutes after the use of specific products, to burn off the residues left inside the oven.



For easier cleaning, remove the door.

Removing racks/trays support frames

Removing the guide frames enables the sides to be cleaned more easily. This operation should be performed each time the automatic cleaning cycle is used (on some models only).

To remove the guide frames: Pull the frame towards the inside of the oven to unhook it from its groove A, then slide it out of the seats B at the back.

When cleaning is complete, repeat the above procedures to put the guide frames back in.

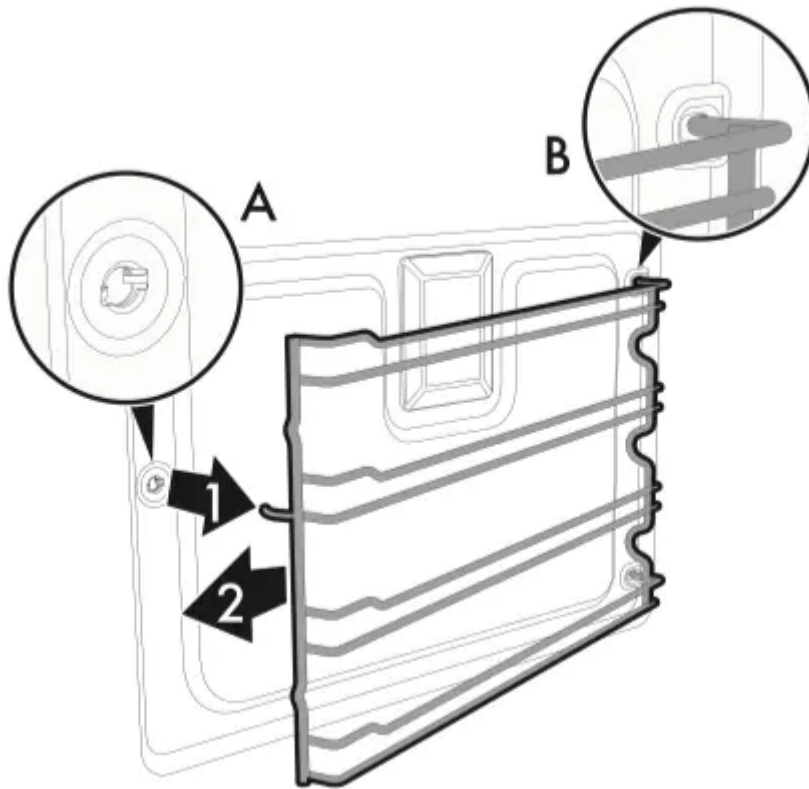

Cleaning the roof of the oven (on some models only)

The appliance is fitted with a tilting heating element which facilitates cleaning the top part (roof) of the oven.

1. Pull the top heating element supports gently towards you.

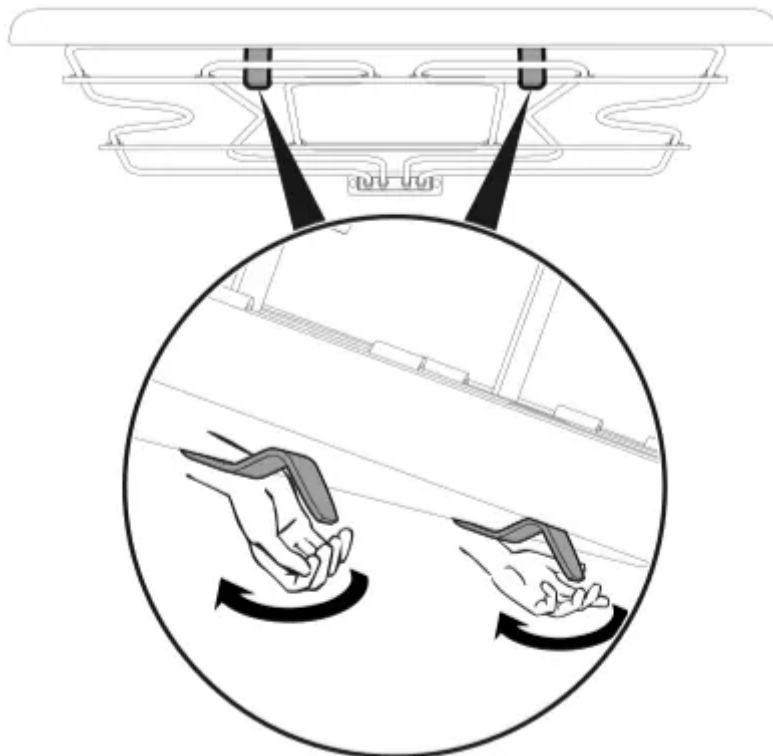

2. Gently lower the element until it stops.

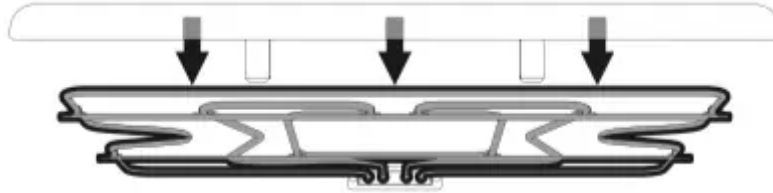

Improper use Risk of damage to the appliance

- Do not bend the heating element excessively while cleaning.
3. When you have finished cleaning, push the heating element back into position on its supports.

Vapor Clean



Vapor Clean is an assisted cleaning procedure which facilitates the removal of dirt. Thanks to this process, it is possible to clean the inside of the oven very easily. The dirt residues are softened by the heat and water vapour for easier removal afterwards.



Improper use Risk of damage to surfaces

- Remove any food residues or large spills from previous cooking operations from the inside of the oven.
- Carry out assisted oven cleaning operations only when the oven is cold.

Preliminary operations

Before starting the Vapor Clean function:

- Place a tray on the first shelf.
- Pour approximately 40 cl of water into the tray. Make sure it does not overflow out of the cavity.

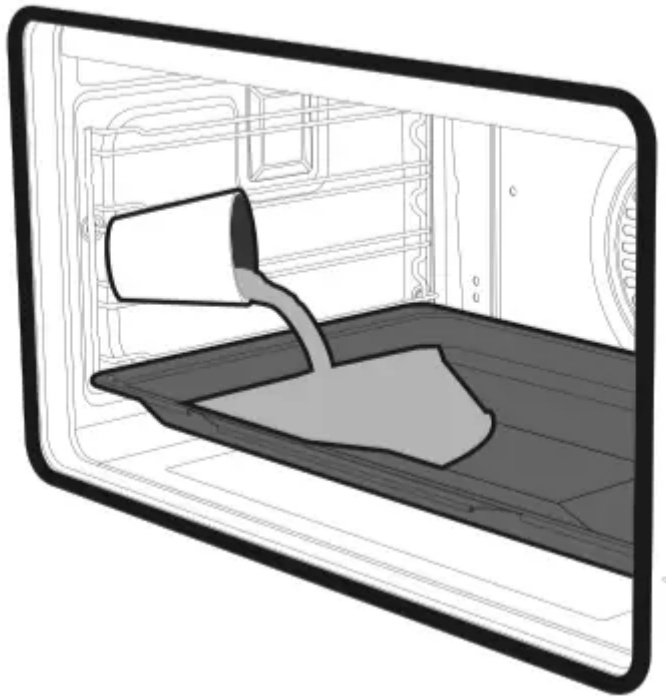

- Spray a water and washing up liquid solution inside the oven using a spray nozzle. Direct the spray against the side walls, upwards, downwards and towards the deflector.

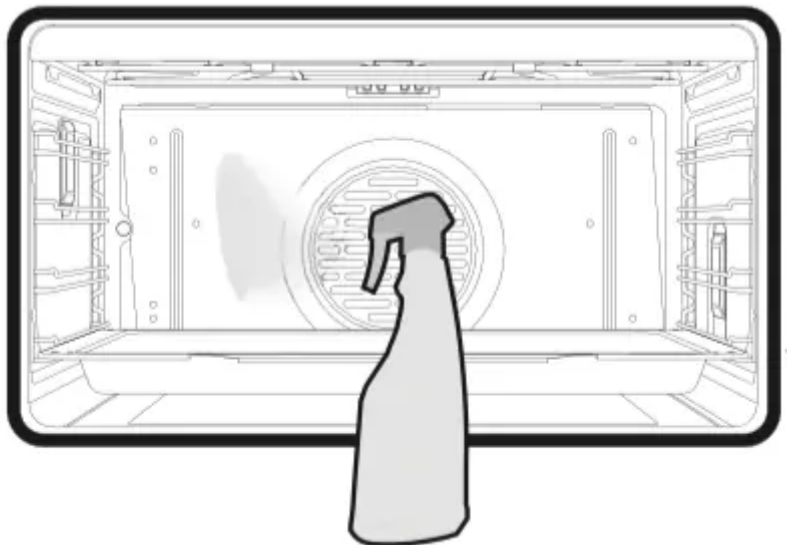

- Close the door.



We recommend spraying approx. 20 times at the most.

Vapor Clean setting

1. Turn the function knob and the temperature knob to the  symbol.

2. Set a cooking duration of 18 minutes using the cooking duration procedure described in more detail in “Programmed cooking”.
3. The Vapor Clean cycle starts approximately 7 seconds after the last pressure on the programmer’s keys.
4. At the end of the Vapor Clean cycle, the timer will deactivate the oven heating elements, the buzzer will start to sound and the numbers on the dial will flash.

End of the Vapor Clean cycle

5. Open the door and wipe away the less stubborn dirt with a microfibre cloth.
6. Use an anti-scratch sponge with brass filaments on tougher encrustations.
7. In case of grease residues use specific oven cleaning products.
8. Remove the water left inside the oven.

For improved hygiene and to avoid food being affected by any unpleasant odours, we recommend that the oven is dried using a fan assisted function at 160°C for approximately 10 minutes.



We recommend wearing rubber gloves for these operations.



For easier manual cleaning of the parts difficult to reach, we recommend removing the door.

Extraordinary maintenance



Live parts

Danger of electrocution

- Disconnect the appliance from the power supply.

Replacing the internal light bulb

1. Completely remove all accessories from inside the oven.
2. Remove the racks/trays support frames.
3. Remove the bulb cover using a tool (e.g. a screwdriver).

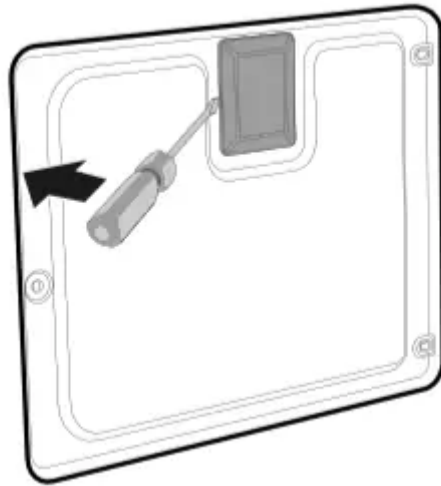

4. Slide out and remove the lamp.

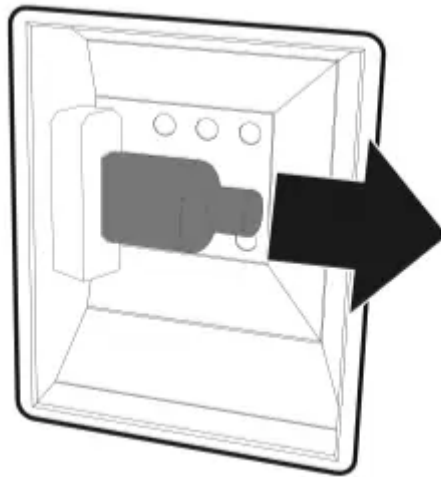

Do not touch the halogen lamp directly with your fingers, but wrap it in insulating material.

5. Replace the lamp with one of the same type (40W).
6. Refit the cover correctly, so that the moulded part of the glass is facing the door.
7. Press the cover completely down so that it attaches perfectly to the bulb support.

Removing the seal of the oven

To permit thorough cleaning of the oven, the door seal can be removed. There are hooks on all four sides to attach it to the edge of the oven. Pull the edges of the seal outwards to detach the hooks.



To keep the seals clean, use a non-abrasive sponge and lukewarm water. Seals should be soft and elastic.

Warning

This content is compiled from multiple sources and is provided for reference purposes only. It may not be complete or fully applicable to all situations. If you are unable to resolve your issue, please contact the product manufacturer or an authorized service provider for official support.

