

## FEATURE DIAGRAM

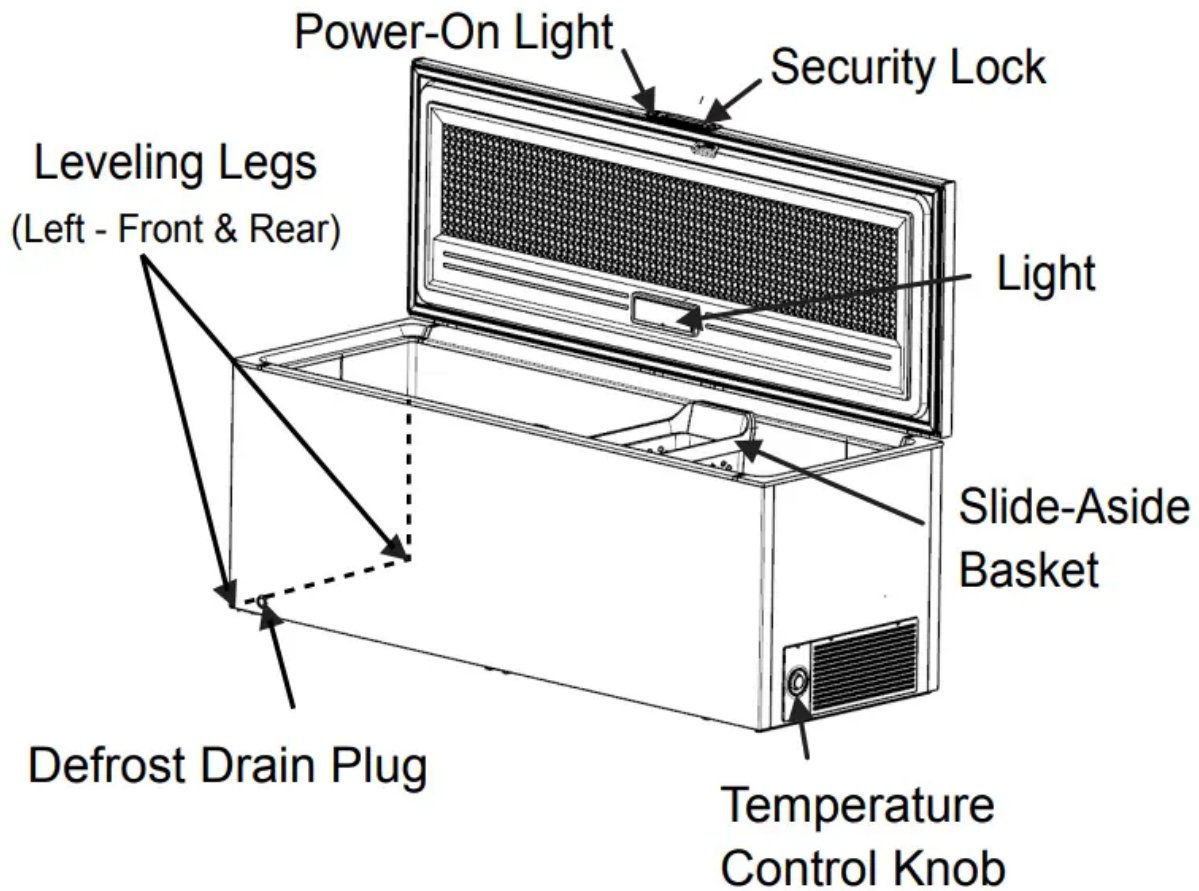

## OPTIONAL FEATURES

### Slide-Aside Basket

This basket helps organize odd-shaped items. To reach other packages in the freezer, slide the basket aside or lift out.

### Defrost Drain

The defrost drain provides a method of draining the water during defrosting and cleaning. See “Defrosting” in Care and Cleaning section.

### LED Lighting

The freezer features maintenance-free LED lighting. To replace, contact an authorized service technician.

### Power On Light

The green Power On light indicates that the freezer is properly connected to electrical power. The light glows even when the temperature control is turned to OFF. If the light goes out, refer to "LIGHT IS NOT ON" in the BEFORE YOU CALL section of this Use & Care Guide.

### **Security Lock with Pop-Out Key**

The Security Lock feature fastens the lid snugly, ensuring the stored food is secure. To lock or unlock the freezer, push the key into the lock and turn. The key pops out of the lock after it has been turned.

## **FIRST STEPS**

### **Location**

Choose a location with a grounded electrical outlet – avoid using any Ground Fault Circuit Interrupter (GFCI) outlets.

Do not use an extension cord or ungrounded (two prong) adapter. At the rear of the freezer, pull power cord straight out of the protective shipping enclosure and unwind enough of the power cord to plug into the electrical outlet.

For the most efficient operation, the freezer should be located where surrounding temperatures will not exceed 110°F (43°C). Temperatures of 32°F (0°C) and below will NOT affect operation. Additional compressor heaters are not recommended.

Allow space around the unit for good air circulation. Leave a 3 inch (75 mm) space on all sides of the unit for adequate circulation.

**NOTE:** The exterior walls of the freezer may become quite warm as the compressor works to transfer heat from the inside. Temperatures as high as 30°F warmer than room temperature can be expected. For this reason it is particularly important in hotter climates to allow enough space for air circulation around your unit.

### **Leveling (optional)**

**NOTE:** It is VERY IMPORTANT for your freezer to be level in order to function properly. If the unit is not leveled during installation, the lid may be misaligned and not close or seal properly, causing cooling, frost, or moisture problems.

Use the leveling legs (located on the left side, front and rear) to ensure that all 4 corners of the freezer are resting firmly on a solid floor. Turn the leveling legs clockwise to retract the legs and counterclockwise to extend the legs. Ensure the floor is strong enough to support a fully loaded freezer.

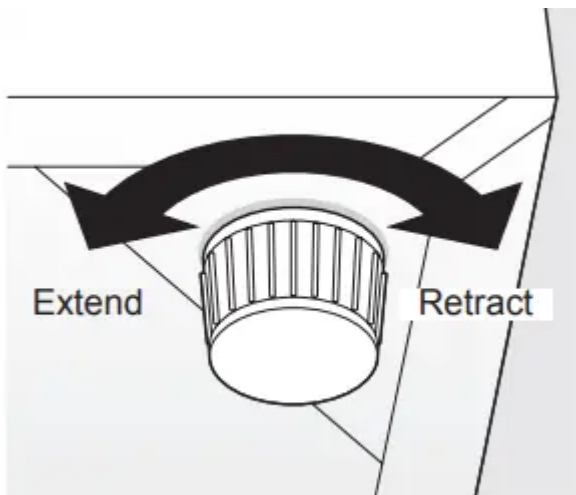

### **Caster Installation (optional)**

**WARNING:** Unplug the unit from power source and empty contents before caster installation. Lock and secure lid to prevent opening during caster installation.

The appliance comes with a caster installation kit shipped in basket of chest freezer. The casters allow ease of moving the unit to its final location. The casters can be then be locked into place.

Required Tool: Phillips head screwdriver

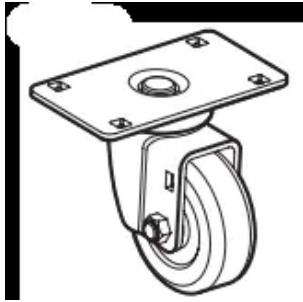
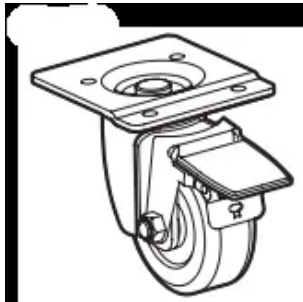
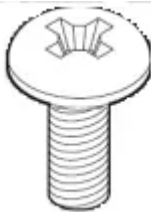
Caster Kit contents:	
Part A 	2 Casters without brakes (13/15 cu. ft.)
	4 Casters without brakes (20/25 cu. ft.)
Part B 	2 Casters with brakes (13/15 cu. ft.)
	2 Casters with brakes (20/25 cu. ft.)
	16 screws (13/15 cu. ft.)
	24 screws (20/25 cu. ft.)

**To install the casters:**

1. Move freezer to a work area that provides sufficient clearance on all 4 sides to allow easy handling and access to the freezer.
2. Cover the floor area behind the freezer with a protective material to prevent damage while it is resting on its back during the caster installation.

**CAUTION:** Two or more people are required to rotate and tilt the freezer on its back, allowing accessibility to all sides.

3. Remove the adjustable leveling legs already installed on the freezer by unscrewing counterclockwise, as they are not required when using casters.
4. Caster installation for the 13/15 cu. ft. freezer: Remove casters and screws from the caster kit. The Part A casters are installed on the right front and rear compressor side of the unit. The Part B



casters are installed on the left front and rear of the unit (with brake lever facing outside). Align the caster holes with the corresponding screw holes in the mounting locations.

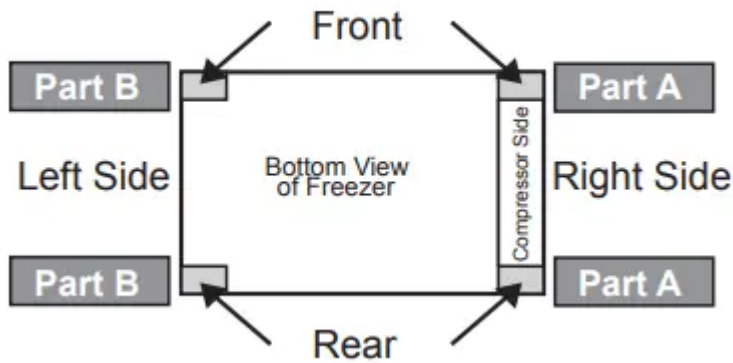

5. Caster installation for the 20/25 cu. ft. freezer: Remove casters and screws from the caster kit. Part A casters are installed on the right front and rear compressor side and middle front and rear of the unit. Part B casters are installed on the left front and rear of the unit (with brake lever facing outside of unit). Line up the caster holes with the corresponding screw holes in the mounting locations.

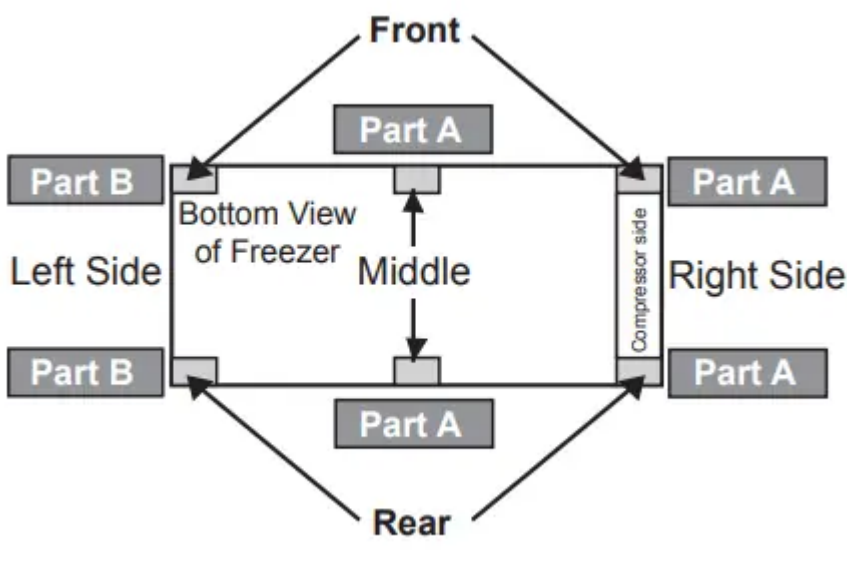

6. After casters are installed, with the help of an assistant, carefully lift and rotate the freezer to its upright position. Move the freezer to the desired location, and engage brakes on the 2 left casters.

7. Wait a minimum of 2 hours before connecting the freezer to an AC power source. Avoid using a Ground Fault Circuit Interrupter (GFCI) outlet. Do not use an extension cord.

8. Install contents to the freezer storage compartment when operating temperature is reached.

**WARNING:** Casters with brakes are to stop chest freezer movement on level ground only. They are not intended to prevent movement on an uneven or sloping floor.

## Cleaning

- Wash any removable parts of the freezer interior and exterior with mild detergent and warm water. Wipe dry. **DO NOT USE HARSH CLEANERS ON THESE SURFACES.**
- Do not use razor blades or other sharp instruments which can scratch the freezer surface when removing adhesive labels. Any glue left from the tape can be removed with a mixture of warm water and mild detergent or the residue can be touched with the sticky side of tape already removed. **DO NOT REMOVE THE SERIAL PLATE.**

## SETTING THE TEMPERATURE CONTROL

### Temperature Control

The temperature control is located on the right outside wall. The temperature is factory preset to provide satisfactory food storage temperatures. The temperature control is adjustable to provide a range of temperatures for your personal satisfaction. If a colder temperature is desired, turn the temperature control knob toward COLDEST and allow 24 hours for temperatures to stabilize between adjustments.

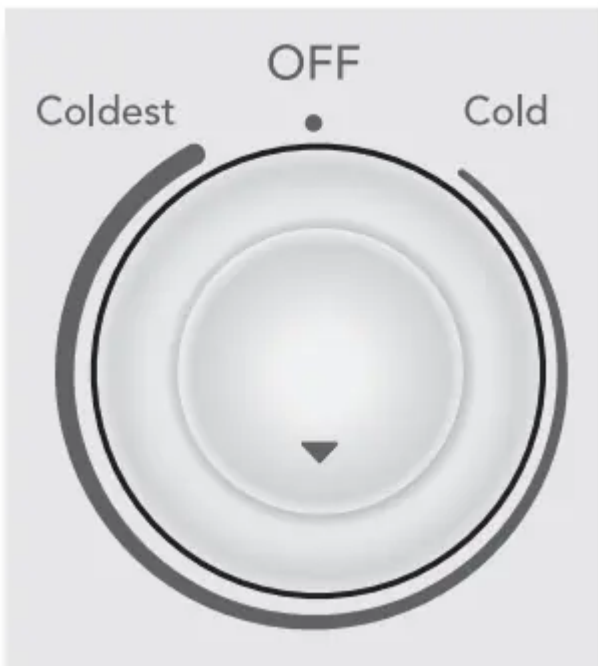

### Cool Down Period

- For safe food storage, allow 4 hours for the freezer to cool down completely. The unit will run continuously for the first several hours. Foods that are already frozen may be placed in the unit after the first few hours of operation. Unfrozen foods should **NOT** be loaded into the freezer until the unit has operated for 4 hours.

- When loading the unit, freeze only 3 pounds of fresh food per cubic foot of freezer space at one time. Distribute packages to be frozen evenly throughout the freezer. It is not necessary to turn temperature control knob to a colder setting while freezing food.

## CARE AND CLEANING

**CAUTION:** Damp objects stick to cold metal surfaces. Do not touch interior metal surfaces with wet or damp hands.

### Between Defrostings

To avoid frequent defrosting, occasionally use a plastic scraper to remove frost. Scrape with a pulling motion. Never use a metal instrument to remove frost.

**CAUTION:** Freezer must be unplugged (to avoid electrical hazard) from power source when cleaning or defrosting unit.

### Defrosting

It is important to defrost and clean the freezer when  $\frac{1}{4}$  to  $\frac{1}{2}$  inch of frost has accumulated. Frost may tend to accumulate faster on the upper part of the unit due to warm, moist air entering the freezer when the door is opened. Remove food and leave the lid open when defrosting the unit. If the frost is soft, remove it by using a plastic scraper.

If the frost is glazed and hard, unscrew drain plug on floor of freezer, and unscrew outside drain plug located on the lower left front of the freezer. Place a shallow pan beneath the drain outlet to collect water. Check pan occasionally so water does not overflow. Replace the drain plugs once defrosting is completed.

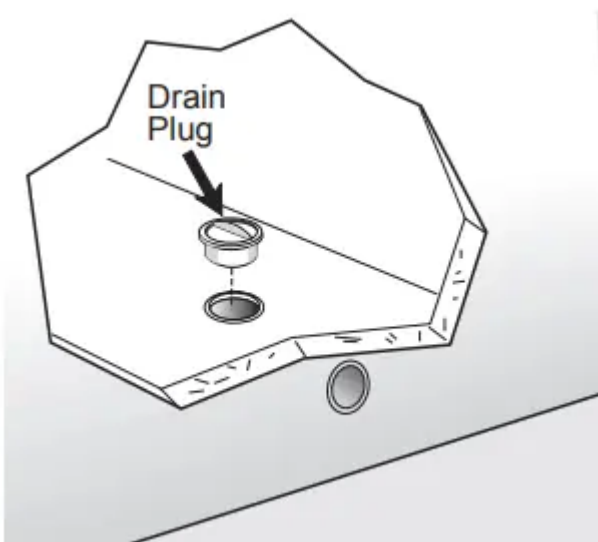

## Cleaning the Inside

After defrosting, wash inside surfaces of the freezer with a solution of 2 tablespoons (25 grams) of baking soda in 1 quart (1.136 litres) warm water. Rinse and dry. Wring excess water out of the sponge or cloth when cleaning in the area of the controls, or any electrical parts.

Wash the removable parts with the baking soda solution mentioned above, or mild detergent and warm water. Rinse and dry. Never use metallic scouring pads, brushes, abrasive cleaners, or alkaline solutions on any surface. Do not wash removable parts in a dishwasher.

## Cleaning the Outside

Wash the cabinet with warm water and mild liquid detergent. Rinse well and wipe dry with a clean soft cloth. Replace parts and food.

## Vacation and Moving Tips

**Short Vacations:** Leave the unit operating during vacations of less than three weeks.

**WARNING:** If leaving freezer lid open while on vacation, make certain that children cannot get into the unit and become entrapped.

**Long Vacations:** If the freezer will not be used for several months, remove all food and unplug the power cord. Clean and dry the interior thoroughly. To prevent odor and mold growth, leave the lid open slightly, blocking it open if necessary.

**Moving:** Disconnect the power cord plug from the wall outlet. Remove food, defrost, and then clean the unit. Secure all loose items, such as baskets, by taping them securely in place to prevent damage. In the moving vehicle, secure the freezer in an upright position, and secure to prevent movement. Also protect outside of the unit with a blanket, or similar item.

## BEFORE YOU CALL



PROBLEM	CAUSE	CORRECTION
FREEZER OPERATION		
Freezer does not run.	Freezer is plugged into a circuit that has a ground fault interrupt.	Use another circuit. If you are unsure about the outlet, have it checked by a qualified electrician.
	Temperature Control is in the OFF position.	See Setting the Temperature Control section.
	Freezer may not be plugged in or plug may be loose.	Ensure plug is tightly pushed into outlet.
	House fuse blown or tripped circuit breaker.	Check/replace fuse with a 15-amp time delay fuse. Reset circuit breaker.
	Power outage	Check house lights. Call a qualified electrician
Freezer runs too much or too long.	Room or outside weather is hot.	It's normal for the freezer to work longer under these conditions.
	Freezer has recently been disconnected for a period of time.	It takes 4 hours for the freezer to cool down completely.
	Large amounts of warm or hot food have been stored recently.	Warm food will cause freezer to run more until the desired temperature is reached.
	Lid is opened too frequently or too long.	Warm air entering the freezer causes it to run more. Open door less often.
	Lid may be slightly open.	Ensure door is tightly closed.
	Temperature control is set too cold.	Turn temperature control knob to a warmer setting. Allow several hours for the temperature to stabilize.

	Gasket is dirty, worn, cracked, or poorly fitted.	Clean or change gasket. Leaks in door seal will cause freezer to run longer in order to maintain desired temperatures.
<b>FREEZER TEMPERATURES</b>		
Interior temperature is too cold.	The temperature is set too cold.	Turn temperature control knob to a warmer setting. Allow several hours for the temperature to stabilize.
Interior temperature is too warm.	Temperature Control is set too warm.	Turn temperature control knob to a colder setting. Allow several hours for the temperature to stabilize.
	Lid is kept open too long or is opened too frequently	Warm air enters the freezer every time the lid is opened. Open the lid less often.
	Lid may not be seating properly	See "LID PROBLEMS" section.
	Large amounts of warm or hot food may have been stored recently	Wait until the freezer has had a chance to reach its selected temperature.
	Freezer has recently been disconnected for a period of time.	Freezer requires 4 hours to cool down completely.
External temperature is warm	The external freezer walls can be as much as 30°F warmer than room temperature.	This is normal while the compressor works to transfer heat from inside the freezer cabinet.
<b>SOUND AND NOISE</b>		
Louder sound levels when freezer is on.	Modern freezers have increased storage capacity and more stable	This is normal. When the surrounding noise is low, you might hear the compressor



	temperatures. They require a high efficiency compressor.	running while it cools the interior.
Longer sound levels when compressor comes on.	Freezer operates at higher pressures during the start of the ON cycle.	This is normal. Sound will level off or disappear as the freezer continues to run.
Popping or cracking sound when compressor comes on.	Metal parts undergo expansion and contraction, as in hot water pipes.	This is normal. Sound will level off or disappear as the freezer continues to run.
Bubbling or gurgling sound, like water boiling.	Refrigerant (used to cool the freezer) is circulating throughout the system.	This is normal.
Vibrating or rattling noise.	Freezer is not level. It rocks on the floor when it is moved slightly.	Level the unit. Refer to "Leveling" in the INSTALLATION section.
	Floor is uneven or weak. Freezer rocks on floor when it is moved slightly.	Ensure floor can adequately support the freezer. Use leveling legs to level the freezer.
	Freezer is touching the wall.	Re-level or move the freezer slightly. Refer to "Leveling" in the INSTALLATION section.
<b>WATER/MOISTURE/FROST INSIDE FREEZER</b>		
Moisture forms on inside walls	Weather is hot and humid.	The rate of frost buildup and internal sweating increases. This is normal.
	Lid may not be seating properly.	See "LID PROBLEMS".
	Lid is opened too often or too long.	Open lid less often
<b>ODOR IN FREEZER</b>		
Odor in freezer.	Interior needs to be cleaned.	



		Clean interior with sponge, warm water, and baking soda.
	Foods with strong odors are in the freezer	Cover the food tightly.
<b>LID PROBLEMS</b>		
Lid will not close.	Freezer is not level. It rocks on the floor when it is moved slightly.	This condition can force the cabinet out of square and misalign the lid. Refer to “Leveling” in the INSTALLATION section.
	Floor is uneven or weak. Freezer rocks on floor when it is moved slightly.	Level the freezer by using leveling legs or brace floor supporting the freezer.
<b>LIGHT IS NOT ON</b>		
Power Available Light is not on.	LED may be burned out.	Contact a qualified service technician.
	No electric current is reaching the freezer.	See “Freezer does not run” in the FREEZER OPERATION section.
Freezer light not on.	LED may be burned out.	Contact a qualified service technician.
	No electric current is reaching the freezer.	See “Freezer does not run” in the FREEZER OPERATION section.

### Warning

This content is compiled from multiple sources and is provided for reference purposes only. It may not be complete or fully applicable to all situations. If you are unable to resolve your issue, please contact the product manufacturer or an authorized service provider for official support.