

PART NAMES

FRONT VIEW

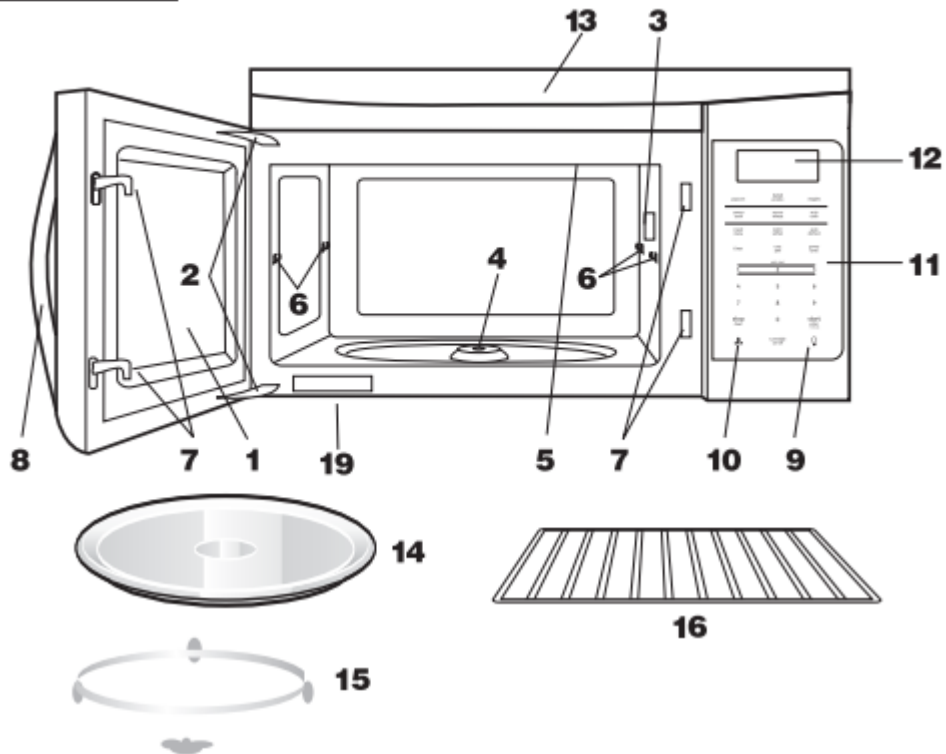

BOTTOM VIEW

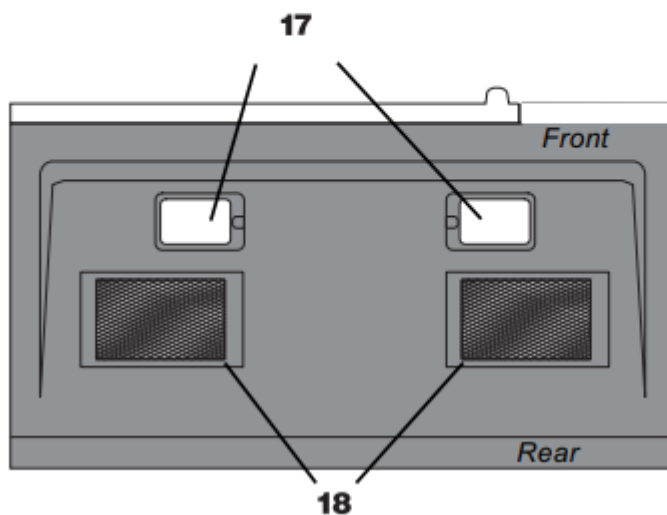

1. Microwave oven door with see-through window
2. Door hinges
3. Waveguide cover: DO NOT REMOVE.
4. Turntable motor shaft
5. Microwave oven light. It will light when microwave oven is operating or door is open.

6. Rack holders
7. Safety door latches. The microwave oven will not operate unless the door is securely closed.
8. Handle
9. Light hi/lo/off pad. Press the light hi/lo/off pad once for high, twice for low and three times to turn off the light.
10. Vent hi/lo/off pad. Press the vent hi/lo/off pad once for high speed, twice for low speed and three times to turn off the fan.
11. Auto-Touch control panel
12. Time display: Digital display, 99 minutes, 99 seconds
13. Ventilation openings
14. Removable turntable. The turntable will rotate clockwise or counter clockwise. Only remove for cleaning.
15. Removable turntable support. First, carefully place the turntable support in the motor shaft in the center of the microwave oven floor. Place the support ring on the microwave oven floor. Then, place the turntable on the turntable support securely.
16. Rack for 2-level cooking/ reheating
17. Light cover
18. Grease filters
19. Menu label

CONTROL PANEL

The 7-digit Interactive Display spells out operating steps and shows cooking hints.

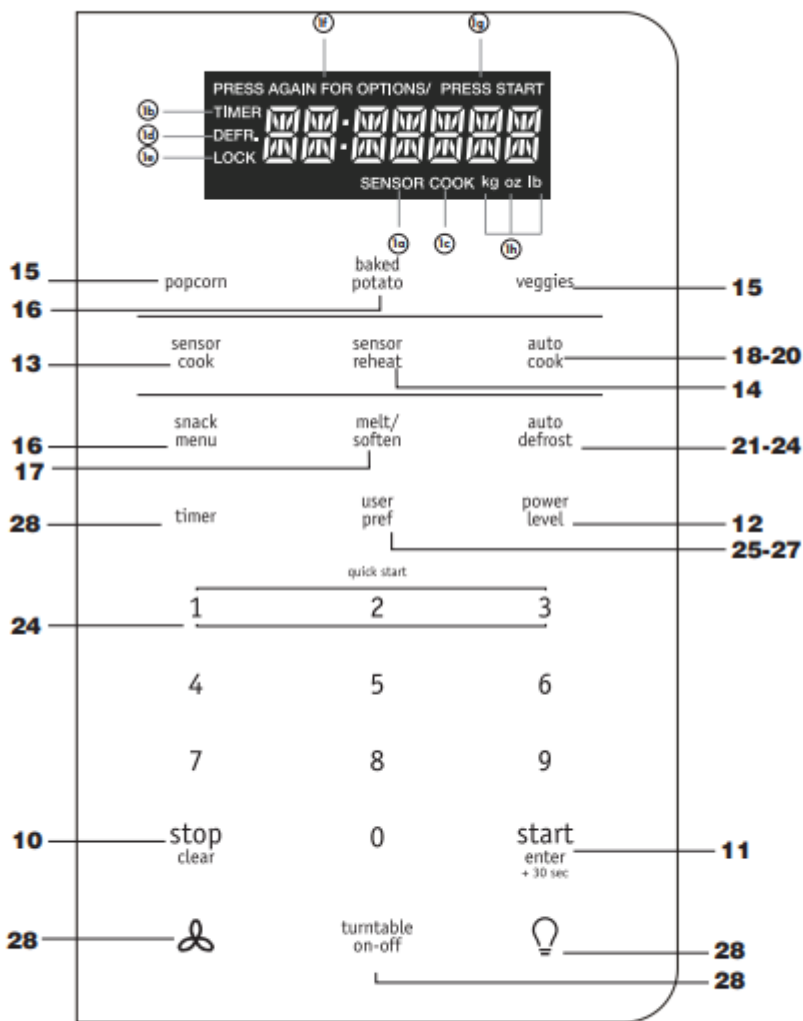

Number next to the control panel illustration indicates pages on which there are feature descriptions and usage information.

1. Display: The display includes a clock and indicators that show the time of day, cooking time settings, cook powers, sensor, quantities, weights and cooking functions selected.

- 1a. SENSOR:** Icon displayed when using sensor cook.
- 1b. TIMER:** Icon displayed when timer is being set or running.
- 1c. COOK:** Icon displayed when starting microwave cooking.
- 1d. DEFR:** Icon displayed when defrosting food
- 1e. LOCK:** Icon displayed in control lock.
- 1f. PRESS AGAIN FOR OPTIONS:** Icon displayed when additional options are available.
- 1g. PRESS START:** Icon displayed when a valid function can be started.

1h, kg, oz, lb: Icon displayed when choosing the weight.

BEFORE OPERATING

- Before operating your new oven make sure you read and understand this Use and Care Guide completely.
- The clock can be disabled when the microwave is first plugged in and the STOP key is selected.

To re-enable the clock follow clock instructions.

To Set the Clock

- Suppose you want to enter the correct time of day 10:59

Touch:	Display Shows:
1. user pref	<small>PRESS AGAIN FOR OPTIONS!</small> 12:00 ENTER TIME
2. (1) (0) (5) (9)	10:59 <small>PRESS START</small>
3. start enter + 30 sec	10:59

STOP clear

Press the **STOP clear** to:

1. Erase if you make a mistake during programming.
2. Cancel timer and the signal after cooking.
3. Stop the oven temporarily during cooking.
4. Return the time of day to the display.
5. Cancel a program during cooking, press twice.

MANUAL COOKING

Time Cooking

Your Over the Range Microwave Oven can be programmed for 99 minutes 99 seconds (99 :99). Always enter the seconds after the minutes, even if they are both zeros.

- Suppose you want to cook for five minutes, 30 seconds at 100% power,

Touch:	Display Shows:
1. (5) (3) (0)	5:30 <small>PRESS START</small>
2. start enter + 30 sec	5:30 <small>COOK</small> Time counting down

Interrupting Cooking

You can stop the oven during a cycle by opening the door. The oven stops heating and the fan turns off, but the light stays on.

To restart cooking, close the door and Touch. **start**
enter
+ 30 sec

If you do not want to continue cooking, open the door and touch **stop**
clear

Using One Touch Start

This is a time saving pad that will automatically start cooking 2 seconds after selected. Numeric key 1, 2, or 3 can be touched for a 1 minute, 2 minute or 3 minute automatic start cooking feature.

Touch:	Display Shows:
1. (2)	2:00 <small>COOK</small> Time counting down

Using Add 30 Sec.

This is a time-saving pad. It is a simplified feature that lets you quickly set and start microwave cooking at 100% power.

- Suppose you want to cook for one minute.

Touch:	Display Shows:
1. start enter + 30 sec	:30 <small>COOK</small>
2. start enter + 30 sec	1:00 <small>COOK</small> Time counting down

Setting Timed Cooking With Power Level

This feature lets you program a specific cook time and power. For best results, there are 10 power level settings in addition to HIGH (100%) power.

- Suppose you want to cook for five minutes, 30 seconds at 80% power.

Touch:	Display Shows:
1. 5 3 0	5:30 <small>PRESS START</small>
2. Power Level x 3	PL-80 <small>PRESS START</small>
3. start enter + 30 sec	5:30 <small>COOK</small> Time counting down

Setting Two-Stage Cooking

For best results, some recipes call for different power levels during a cook cycle. You can program your oven for two power level stages during the cooking cycle.

- Suppose you want to set a 2-stage cook cycle. The first stage is a 3 minute cook time at 80% cook power then a 7 minute cook time at 50% cook power.

Touch:	Display Shows:
1. 3 0 0 To set a 3 minute cook time for first stage.	3:00 <small>PRESS START</small>
2. Power Level x 3	PL-80 <small>PRESS START</small>
3. 7 0 0 To set a 7 minute cook power for the second stage.	7:00 <small>PRESS START</small>
4. Power Level x 6	PL-50 <small>PRESS START</small>
5. start enter + 30 sec	3:00 <small>COOK</small> Time counting down

To Set Power Level

There are eleven preset power levels.

Using lower power levels increases the cooking time which is recommended for foods such as cheese, milk and long slow cooking of meats. Consult cookbook or recipes for specific recommendations.

PRESS POWER LEVEL PAD NUMBER OF TIMES FOR DESIRED POWER	APPROXIMATE PERCENTAGE OF POWER	COMMON WORDS FOR POWER LEVELS
POWER LEVEL x 1	100%	High
POWER LEVEL x 2	90%	
POWER LEVEL x 3	80%	
POWER LEVEL x 4	70%	Medium High
POWER LEVEL x 5	60%	
POWER LEVEL x 6	50%	Medium
POWER LEVEL x 7	40%	
POWER LEVEL x 8	30%	Med Low/Defrost
POWER LEVEL x 9	20%	
POWER LEVEL x 10	10%	Low
POWER LEVEL x 11	0%	

Using the Rack

The rack allows several foods to be cooked or reheated at one time. However, for the best cooking and reheating, use Turntable ON function and cook with SENSOR COOKING or AUTO COOKING without the rack. When the rack is used, set time and power level manually. Allow plenty of space around and between the dishes. Pay close attention to the cooking and reheating progress. Reposition the foods and reverse them from the rack to turntable and/or stir them at least once during any cooking or reheating time. After cooking or reheating, stir if possible. Using a lower power level will assist in better cooking and reheating uniformity.

Avoid:

- Storing the rack in the microwave oven when not in use.
- Popping popcorn with the rack in the microwave oven.
- Using any browning dish on the rack.
- Using SENSOR COOKING and AUTO COOKING with the rack.
- Cooking directly on the rack—use microwave-safe cookware.

Manual Defrost

If the food that you wish to defrost is not listed on the Defrost chart or is above or below the limits in the Amount column on the Defrost chart (see page 22-23), you need to defrost manually.

You can defrost any frozen food, either raw or previously cooked, by using power level for 30%.

For either raw or previously cooked frozen food the rule of thumb is approximately 4 minutes per pound. For example, defrost 4 minutes for 1 pound of frozen spaghetti sauce.

Always stop the oven periodically to remove or separate the portions that are defrosted. If food is not defrosted at the end of the estimated defrosting time, program the oven in 1 minute increments on power level 30% until totally defrosted.

When using plastic containers from the freezer, defrost only long enough to remove from the plastic in order to place in a microwave-safe dish.

SENSOR COOKING

Sensor cooking has an electronic controlled sensor that detects the vapor (moisture and humidity) emitted from the food as it heats. The sensor adjusts the cooking times and power level for various foods and quantities automatically.

Using Sensor Settings:

1. Be sure the exterior of the cooking container and the interior of the oven are dry. Wipe off any moisture with a dry cloth or paper towel.
2. The oven works with foods at normal storage temperature. For example, popcorn would be at room temperature.
3. More or less food than the quantity listed in the chart should be cooked following the guidelines in any microwave cookbook.
4. During the first part of SENSOR COOKING, food name will appear in the display. Do not open the oven door or press the **STOP clear** pad during this part of the cycle. The measurement of vapor will be interrupted.

When the sensor detects the vapor emitted from the food, remainder of cooking time will appear. Door may be opened when remaining cooking time appears in the display. At this time, you may stir or season food, as desired.

5. If the sensor does not detect vapor properly when popping popcorn, the oven will turn off, and the correct time of day will be displayed. If the sensor does not detect vapor properly when cooking other foods, AN ERROR CODE will be displayed, and the oven will turn off.

6. Check food for temperature after cooking. If additional time is needed, continue to cook manually.

Covering Foods:

Some foods cook better when covered.

1. Casserole lid.

2. Plastic wrap: Use plastic wrap recommended for microwave cooking. Cover dish loosely; allow approximately 1/2 inch to remain uncovered to allow steam to escape. Plastic wrap should not touch food.

3. Wax paper: Cover dish completely; fold excess wrap under dish to secure. If dish is wider than paper, overlap two pieces at least one inch to cover.

Be careful when removing any covering to allow steam to escape away from you.

NOTES for SENSOR COOKING

1. The final cooking result will vary according to the food condition (e.g. initial temperature, shape, quality). Check food for temperature after cooking. If additional time is needed, continue to cook manually.
2. Stay near the oven while it's in use and check cooking progress frequently so that there is no chance of overcooking food.
3. When SENSOR COOKING are selected Turntable On is automatically set for optimum cooking.

Sensor Cook

You can cook foods by pressing the **sensor cook** pad

- Suppose you want to cook frozen breakfast

Touch:	Display Shows:
1. sensor cook	PRESS AGAIN FOR OPTIONS/ PRESS START BACON SENSOR
2. sensor cook	PRESS AGAIN FOR OPTIONS/ PRESS START FROZEN DINNER SENSOR
3. sensor cook	PRESS AGAIN FOR OPTIONS/ PRESS START RICE SENSOR
4. sensor cook	PRESS AGAIN FOR OPTIONS/ PRESS START FROZEN BREAKFAST SENSOR
5. start enter + 30 sec	FROZEN BREAKFAST SENSOR COOK

Sensor Cook chart

FOOD	AMOUNT	PROCEDURE
1. Bacon	1-3 slices	Place bacon strips on a microwave bacon rack for (Use dinner plate lined with paper towels if rack is available).
2. Frozen Dinner	10 oz./ 20 oz.	Place in a appropriately sized microwave contain plastic wrap . After cooking, stir and allow to stan minutes.
3. Rice	1-2 cups Use medium or long grain rice. Cook instant rice according to directions on the package.	Place rice and twice as much liquid (water, chick vegetable stock) in a 2 quart microwave dish. Co wrap and vent. After cooking, allow to stand for 1 for fluffier rice.
4. Frozen Breakfast	8/12 oz.	Place in a appropriately sized microwave contain plastic wrap . After cooking, stir and allow to stan minutes.

Sensor Reheat

- Suppose you want to reheat rolls with sensor reheat.

Touch:	Display Shows:
1. sensor reheat	<small>PRESS AGAIN FOR OPTIONS/ PRESS START</small> DINNER PLATE <small>SENSOR</small>
2. sensor reheat	<small>PRESS AGAIN FOR OPTIONS/ PRESS START</small> SOUP SAUCE <small>SENSOR</small>
3. sensor reheat	<small>PRESS AGAIN FOR OPTIONS/ PRESS START</small> CASSEROLE <small>SENSOR</small>
4. sensor reheat	<small>PRESS AGAIN FOR OPTIONS/ PRESS START</small> ROLLS <small>SENSOR</small>
5. start enter + 30 sec	ROLLS <small>SENSOR COOK</small>

Sensor Reheat chart

FOOD	AMOUNT	PROCEDURE
Dinner Plate	1-2 Plates	Place on a low plate. Cover with vented plastic wrap. Let stand 3 minutes after cooking.
Soup/Sauce	1-2 Cups	Place in shallow microwavable casserole. Cover with vented plastic wrap. After cooking, stir and let stand 3 minutes.
Casserole/ Lasagna	1-4 Servings	Place in a microwavable bowl or casserole. Cover with vented plastic wrap. After cooking, stir and let stand 3 minutes.
Roll/Muffin	1-3 Pieces	Place on paper towel. Do not cover.

ONE TOUCH COOK

Popcorn

The Popcorn quick touch pad lets you pop 3.3, 3.0, 1.75 ounce bags of commercially packaged microwave popcorn. Pop only one package at a time. If you are using a microwave popcorn popper, follow manufacturer's instructions.

- Suppose you want to pop a 3.3 oz. popcorn.

Touch:	Display Shows:
1. popcorn	<small>PRESS AGAIN FOR OPTIONS! PRESS START</small> 3.3 <small>oz</small>
2. start enter + 30 sec	POPCORN <small>COOK</small> Time counting down

Amount	Press popcorn pad
3.30 oz.	once
3.00 oz.	2 times
1.75 oz.	3 times

Veggies

There are 2 options (Frozen Vegetables , Fresh Vegetables) under the Veggies.

- Suppose you want to cook two cups of frozen veggies.

Touch:	Display Shows:
1. veggies	<small>PRESS AGAIN FOR OPTIONS/ PRESS START</small> FRESH
2. veggies	<small>PRESS AGAIN FOR OPTIONS/ PRESS START</small> FROZEN
3. start enter + 30 sec	FROZEN VEGGIES <small>COOK</small> Time counting down

FOOD (Initial temperature)	AMOUNT	PROCEDURE
1. Frozen Vegetables (-18 oC)	4 - 24 oz 0.2 - 0.7 kg	Add no water. Cover with lid or plastic wrap. Press the vegetables pad two times for Frozen Vegetables. After cooking, let stand, covered, for 3 minutes.
2. Fresh Vegetables (5oC) Broccoli Brussels sprouts Cabbage Cauliflower (flowerets) Cauliflower (whole) Spinach Zucchini	4 - 24 oz 0.2 - 0.7 kg	Wash and place in casserole. Add no water if vegetables have been washed. Cover with lid for tender vegetables. Use plastic wrap for tender-crisp vegetables. Press the vegetables pad two times for fresh Vegetables. After cooking, stir, if possible, and let stand, covered, for 2 to 5 minutes.
Carrots, sliced Corn on cob Green beans Winter squash - diced - halves		Place in casserole. Add 1-4 tbsp. water. Cover with lid for tender vegetables. Use plastic wrap cover for tender-crisp vegetables. Press the vegetables pad and number 1 for fresh Vegetables. After cooking stir, if possible. Let stand, covered, for 3 to 5 minutes.

Snack Menu

Snack Menu is for cooking/heating foods that take a short amount of time!

- Suppose you want to reheat 2 cups of beverage.

Touch:	Display Shows:
1. snack menu	<small>PRESS AGAIN FOR OPTIONS/ PRESS START</small> BEVERAGE
2. start enter + 30 sec	1-3 CUP
3. ②	<small>PRESS START</small> 2 CUPS
4. start enter + 30 sec	BEVERAGE <small>COOK</small> Time counting down

Snack Menu chart

FOOD	AMOUNT	PROCEDURE
1. Beverage	1 - 3 cups	To reheat beverages. Stir liquid briskly before and after heating to avoid "eruption" .
2. Frozen MW Pizza	(6 - 8 oz) (170 - 225 g)	Use for frozen microwave pizza. Remove from package and unwrapped package directions for use of package and/or silver crisping disk.
3. Hot Dogs	1 - 6 pieces	Place hot dog in bun. Wrap each with paper towel or napkin.
4. Meal in a Cup	2.39 oz	This setting is ideal for individual portions of canned food packed in a microwaveable container, usually 6 to 8 ounces. Remove inner microwaveable lid. After cooking, stir food and allow to stand for 1 to 2 minutes.
5. Frozen Kid's Meal	8.8 oz	Use this pad for frozen, convenience foods. It will give satisfactory results for most brands. You may wish to try several and choose your favorite. Remove the package from outer wrapping and follow package directions for covering. After cooking, let stand, covered for 1 to 3 minutes.

Baked Potato

- Suppose you want to cook 1 to 4 baked Potatoes.

Touch:	Display Shows:
1. baked potato	PRESS START POTATO SENSOR
2. start enter + 30 sec	POTATO SENSOR COOK

Baked Potato chart



FOOD	AMOUNT	PROCEDURE
Baked Potato*	1 - pieces	Pierce with fork in several places. Place on paper towel on turntable cooking, remove from oven and let stand for 5 minutes.

Setting Melt/Soften

The oven uses low power to melt and soften items. See the following table.

- Suppose you want to melt 2 sticks of Butter.

Touch:	Display Shows:
1. melt/ soften	<small>PRESS AGAIN FOR OPTIONS/ PRESS START</small> MELT BUTTER
2. start enter + 30 sec	ENTER 1-2 STK
3. ②	<small>PRESS START</small> 2 STICK
4. start enter + 30 sec	MELT BUTTER <small>COOK</small> Time counting down

CATEGORY	AMOUNT	DIRECTION
BUTTER	1 or 2 sticks	Unwrap and place in microwavable container. No need to cover butter. Stir at the end of cooking to complete melting.
CHOCOLATE	2, 4 or 8 oz.	Chocolate chips or squares of baking chocolate may be used. Unwrap squares and place in microwavable container. Stir at the end of cycle to complete melting.
ICE CREAM	Pint, 1.5 Quart.	Place container in oven. Ice cream will be soft enough to make scooping easier.
CREAM CHEESE	3 or 8 oz.	Unwrap and place in microwavable container. Cream cheese will be at room temperature and ready for use in recipe.

AUTO COOKING

Auto Cook

Auto cook is divided into 2 parts-Quick Meals (Scrambled Eggs, Hot Cereal, Frozen Pizza, Fudge Brownies) and Dinner Recipes (Garlic Shrimp, Asiago Red Potatoes, Roasted Vegetable Medley, Lemon and Shrimp Risotto, White Chicken Chilli).

Key	Food	Amount
Snacks x1	Scrambled Eggs	1 - 6 Eggs
Snacks x2	Hot Cereal	1 - 3 Servings
Snacks x3	Frozen Pizza	12 oz
Snacks x4	Fudge Brownies	
Snacks x5	Garlic Shrimp	Per Recipe
Snacks x6	Stuffed Mushrooms	Per Recipe
Snacks x7	Asiago Red Potatoes	Per Recipe
Snacks x8	Roasted Vegetable Medley	Per Recipe
Snacks x9	Lemon and Shrimp Risotto	Per Recipe
Snacks x10	White Chicken Chili	Per Recipe

Quick Meals

- Suppose you want to cook Hot Cereal for 1 serving .

Touch:	Display Shows:
1. auto cook	<small>PRESS AGAIN FOR OPTIONS/ PRESS START</small> SCRAMBLED EGGS
2. auto cook	<small>PRESS AGAIN FOR OPTIONS/ PRESS START</small> HOT CEREAL
3. start enter + 30 sec	1-3 SERVING
4. (3)	<small>PRESS START</small> 3 SERVINGS
5. start enter + 30 sec	HOT CEREAL <small>COOK</small> Time counting down

Quick Meals chart		
FOOD	AMOUNT	PROCEDURE
1. Scrambled Eggs	1 - 6 eggs	Whisk together egg and milk (use 1/2 tablespoon milk for each egg) in a safe bowl that has been coated with cooking spray. Select "Scrambled Eggs" under the Auto Cook menu and the desired number of eggs to be cooked. Stir through cooking time.
2. Hot Cereal	1- 3 servings	Use individual packets or bulk cereal in your favorite variety: oatmeal, oatmeal of wheat, farina or wheatena. Follow package directions for the correct amount of water or milk. To prevent boilovers, it is very important to choose a large microwave safe bowl because microwave cooking of cereal causes high boiling. Select "Hot Cereal" under the Auto Cook menu and the desired number servings.
3. Frozen Pizza	12 oz	Use for frozen microwave pizza. Remove from package and unwrap. Follow package directions for use of package and/or silver crisping disk.
4. Fudge Brownies	18-19 oz	Prepare brownie mix according to package directions. Spoon batter into a microwave safe glass dish that has been coated with cooking spray. Select "Fudge Brownies" under the Auto Cook menu.

Dinner Recipes

- Suppose you want to cook Garlic shrimp.

Touch:	Display Shows:
1. auto cook	<small>PRESS AGAIN FOR OPTIONS/ PRESS START</small> SCRAMBLED EGGS
2. auto cook	<small>PRESS AGAIN FOR OPTIONS/ PRESS START</small> HOT CEREAL
3. auto cook	<small>PRESS AGAIN FOR OPTIONS/ PRESS START</small> FROZEN PIZZA
4. auto cook	<small>PRESS AGAIN FOR OPTIONS/ PRESS START</small> FUDGE BROWNIES
5. auto cook	<small>PRESS AGAIN FOR OPTIONS/ PRESS START</small> GARLIC SHRIMP
6. start enter + 30 sec	GARLIC SHRIMP <small>COOK</small> Time counting down

AUTO DEFROST

Using Auto Defrost

The auto defrost feature provides you with the best defrosting method for frozen foods. The cooking guide will show you which defrost sequence is recommended for the food you are defrosting.

For added convenience, the Auto Defrost includes a built-in beep mechanism that reminds you to check, turn over, separate, or rearrange the food in order to get the best defrost results. Three different defrosting levels are provided:

1. MEAT
2. POULTRY
3. FISH

Available weight is 0.1-6.0 lbs

- Suppose you want to defrost 1.2 lbs of fish.

Touch:	Display Shows:
1. auto defrost	PRESS AGAIN FOR OPTIONS/ PRESS START MEAT
2. auto defrost	PRESS AGAIN FOR OPTIONS/ PRESS START POULTRY
3. auto defrost	PRESS AGAIN FOR OPTIONS/ PRESS START FISH
4. start enter + 30 sec	ENTER WEIGHT
5. (1) and (2) To enter weight	1.2 PRESS START
6. start enter + 30 sec	DEFN. FISH Time counting down

Operating Tips

- For best results, remove fish, shell fish, meat and poultry from its original closed paper or plastic package (wrapper). Otherwise, the wrap will hold steam and juice close to the foods, which can cause the outer surface of the foods to cook.
- For best results, roll your ground meat into a ball before freezing. During the DEFROST cycle, the microwave will signal when it is time to turn the meat over. Scrape off any excess frost from the meat and continue defrosting.
- Place foods in a shallow container or on a microwave roasting rack to catch drippings.

This table shows food type selections and the weights you can set for each type. For best results, loosen or remove covering on food.

KEY PRESS	Category	WEIGHTS YOU CAN SET (tenths of a pound)
Defrost	Meat	0.1 to 6.0
Defrost	Poultry	0.1 to 6.0
Defrost	Fish	0.1 to 6.0

Weight conversion table

You are probably used to measuring food in pounds and ounces that are fractions of a pound (for example, 4 ounces equals 1/4 pound). However, in order to enter food weight in Auto Defrost, you must specify pounds and tenths of a pound.

If the weight on the food package is in fractions of a pound, you can use the following table to convert the weight to decimals.

Equivalent Weight	
OUNCES	DECIMAL WEIGHT
1.6	.10
3.2	.20
4.0	.25 One-Quarter Pound
4.8	.30
6.4	.40
8.0	.50 One-Half Pound
9.6	.60
11.2	.70
12.0	.75 Three-Quarters Pound
12.8	.80
14.4	.90
16.0	1.0 One Pound

Defrosting Tips

- When using Auto Defrost, the weight to be entered is the net weight in pounds and tenths of pounds (the weight of the food minus the container).
- Beforeg Startin, make sure to remove any and all metal twist-ties that often come with frozen food bags, and replace them with strings or elastic bands.
- Open containers, such as cartons, before placing in the oven.
- Always slit or pierce plastic pouches or packaging.
- If food is foil wrappe, remove foil and place food in a suitable container.
- Slit the skin of skinned food, such as sausage.
- Bend plastic pouches of food to ensure even defrosting.
- Always underestimate defrosting time. If defrosted food is still icy in the center, return it to the microwave oven for more defrosting.
- The length of defrosting time varies according to how solidly the food is frozen.
- The shape of the package affects how quickly food will defrost. Shallow packages will defrost more quickly than a deep block.
- As food begins to defrost, separate the pieces. Separated pieces defrost more easily.
- Use small pieces of aluminum foil to shiele parts of food such as chicken wings, leg tips, fish tails, or areas that start to get warm. Make sure the foil does not touch the sides, top, or bottom of the oven. The foil can damage the oven lining.

- For better results, let food stand after defrosting.
- Turn over food during defrosting or standing time. Break apart and remove food as required.

CLEANING AND CARE

EXTERIOR

The outside surface is precoated steel and plastic. Clean the outside with mild soap and water; rinse and dry with a soft cloth. Do not use any type of household or abrasive cleaner.

DOOR

Wipe the window on both sides with a soft cloth to remove any spills or splatters. Metal parts will be easier to maintain if wiped frequently with a soft cloth. Avoid the use of spray and other harsh cleaners as they may stain, streak or dull the door surface.

EASY CARE™ STAINLESS STEEL

(SOME MODELS)

Your microwave oven finish may be made with Easy Care™ Stainless Steel (some models). Clean the stainless with warm soapy water using a clean sponge or cloth. Rinse with clean water and dry with a soft clean cloth. **DO NOT** use ANY store bought cleaners like Stainless Steel cleaners or any other types of cleaners containing any abrasive, chlorides, chlorines or ammonia. It is recommended to use mild dish soap and water or a 50/50 solution of water and vinegar.

TOUCH CONTROL PANEL

Care should be taken in cleaning the touch control panel. If the control panel becomes soiled, open the microwave oven door before cleaning. Wipe the panel with a cloth dampened slightly with water only. Dry with a soft cloth. Do not scrub or use any sort of chemical cleaners. Close door and touch **STOP/CLEAR**

INTERIOR

Cleaning is easy because little heat is generated to the interior surfaces. To clean the interior surfaces, wipe with a soft cloth and warm water. **DO NOT USE ABRASIVE OR HARSH CLEANERS OR SCOURING PADS.** For heavier soil, use baking soda or a mild soap; rinse thoroughly with hot water. The round wire rack and shelf can be cleaned with hot soapy water, rinsed and dried.

WAVEGUIDE COVER

The waveguide cover is located on the side in the microwave oven cavity. It is made from mica so requires special care. Keep the waveguide cover clean to assure good microwave oven performance. Carefully wipe with a damp cloth any food splatters from the surface of the cover

immediately after they occur. Built-up splashes may overheat and cause smoke or possibly catch fire. DO NOT REMOVE THE WAVEGUIDE COVER.

ODOR REMOVAL

Occasionally, a cooking odor may remain in the microwave oven. To remove, combine 1 cup water, grated peel and juice of 1 lemon and several whole cloves in a 2-cup glass measuring cup. Boil for several minutes using 100% power. Allow to set in microwave oven until cool. Wipe interior with a soft cloth.

TURNTABLE/TURNTABLE SUPPORT

The turntable and turntable support can be removed for easy cleaning. Wash them in mild, sudsy water; for stubborn stains use a mild cleanser and non-abrasive scouring sponge. They are also dishwasher-proof. Use upper wickerack of dishwasher. The turntable motor shaft is not sealed, so excess water or spills should be wiped up immediately.

Cleaning the exhaust filters

The oven ventilation exhaust filters should be removed and cleaned often; generally at least once every month.

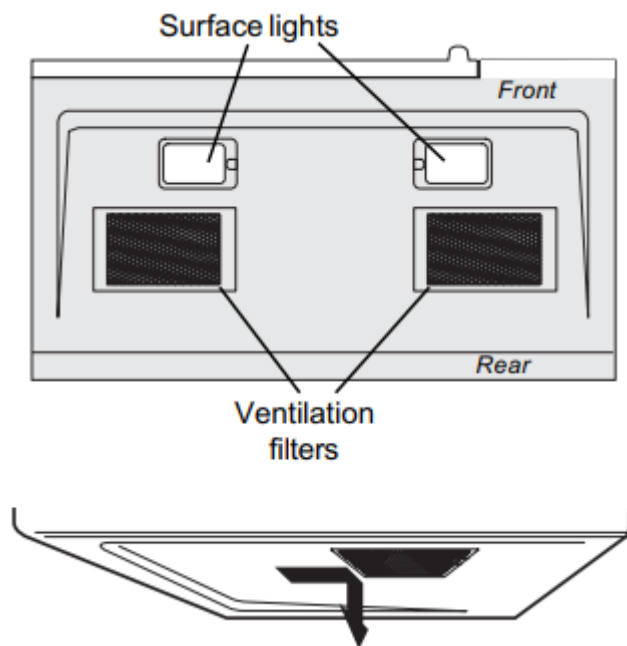

1. To remove the exhaust ventilation filters, slide the filter to the rear. Then pull filter downward and push to the other side. The filter will drop out. Repeat for the 2nd filter.

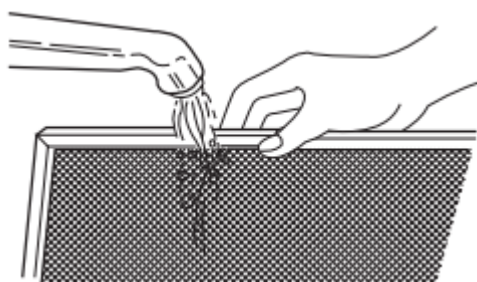

2. Soak the ventilation filters in hot water using a mild detergent. Rinse well and shake to dry or wash in a dishwasher. **Do not use ammonia. The aluminum on the filter will corrode and darken.**



3. To reinstall the exhaust ventilation filter, slide it into the side slot, then push up and toward oven to lock. Reinstall the 2nd filter using the same procedure.

Surface light replacement

1. Unplug the microwave oven or turn off power at the main circuit breaker.
2. Remove the bulb cover mounting screws at both light positions under the microwave.

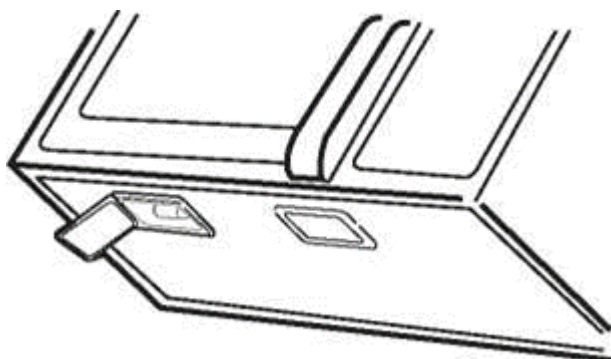

3. Replace bulb with 30 watt appliance bulb.
4. Re-install bulb cover and mounting screw.
5. Plug the microwave back into the power supply or turn the power back on at the main circuit breaker.

Charcoal filter replacement

Charcoal Filter installed in your microwave oven, is used for nonvented, recirculated installation. The filters should be changed every 6 to 12 months depending on use.

1. Disconnect power to the microwave oven at the circuit breaker panel or by unplugging.
2. Remove the vent grill mounting screws.

3. Pull the vent grill away from the unit.

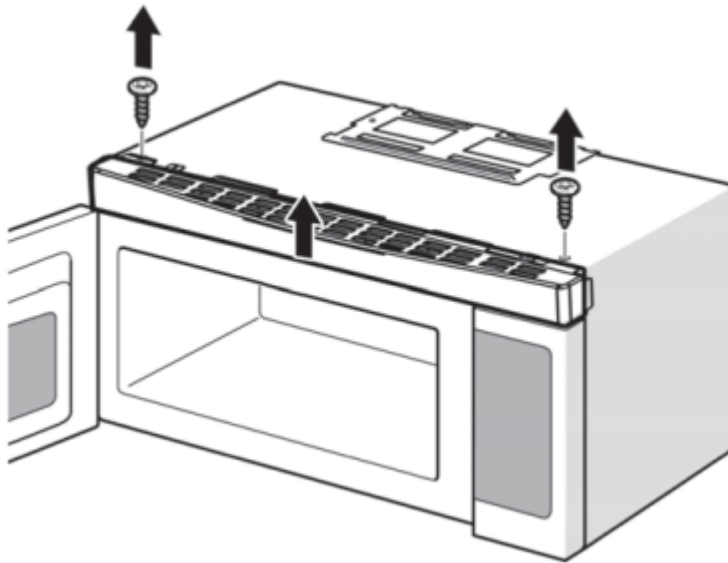

4. Remove the charcoal filter by pushing it inwards, then turn and pull it away from the unit.

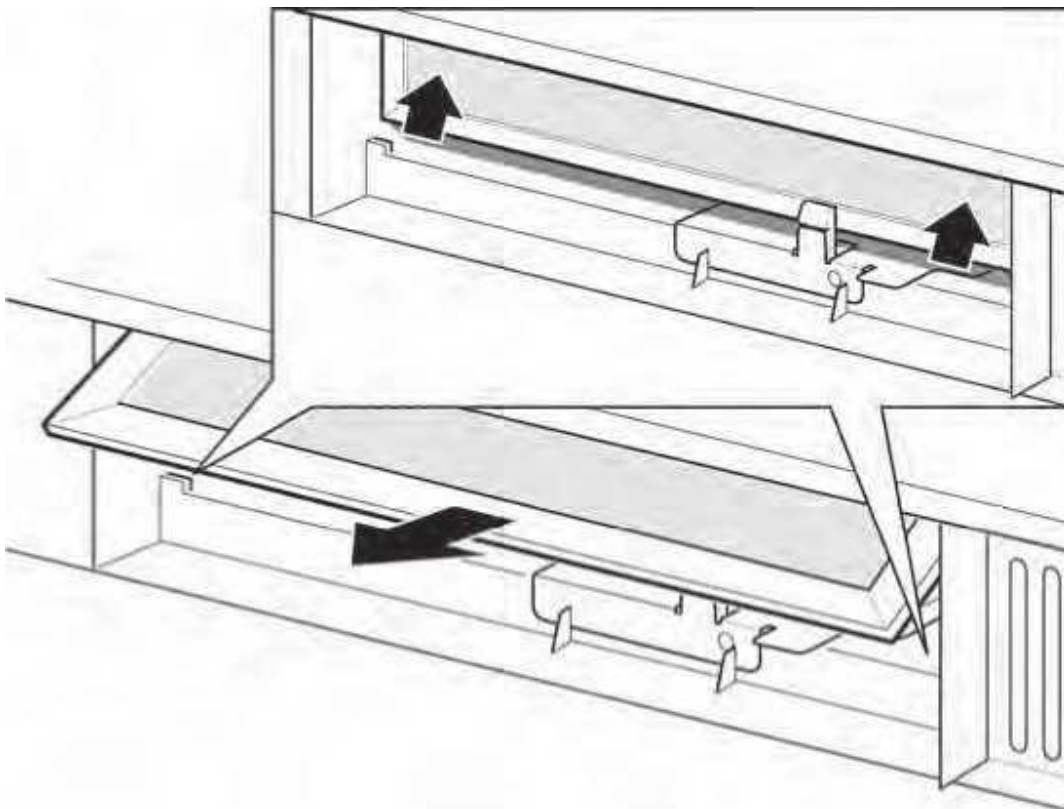

Oven light replacement

Remove the vent grill per instructions 1-4 above and charcoal filter, if used.

1. Open light cover located behind filter mounting by carefully pulling up on the front edge.

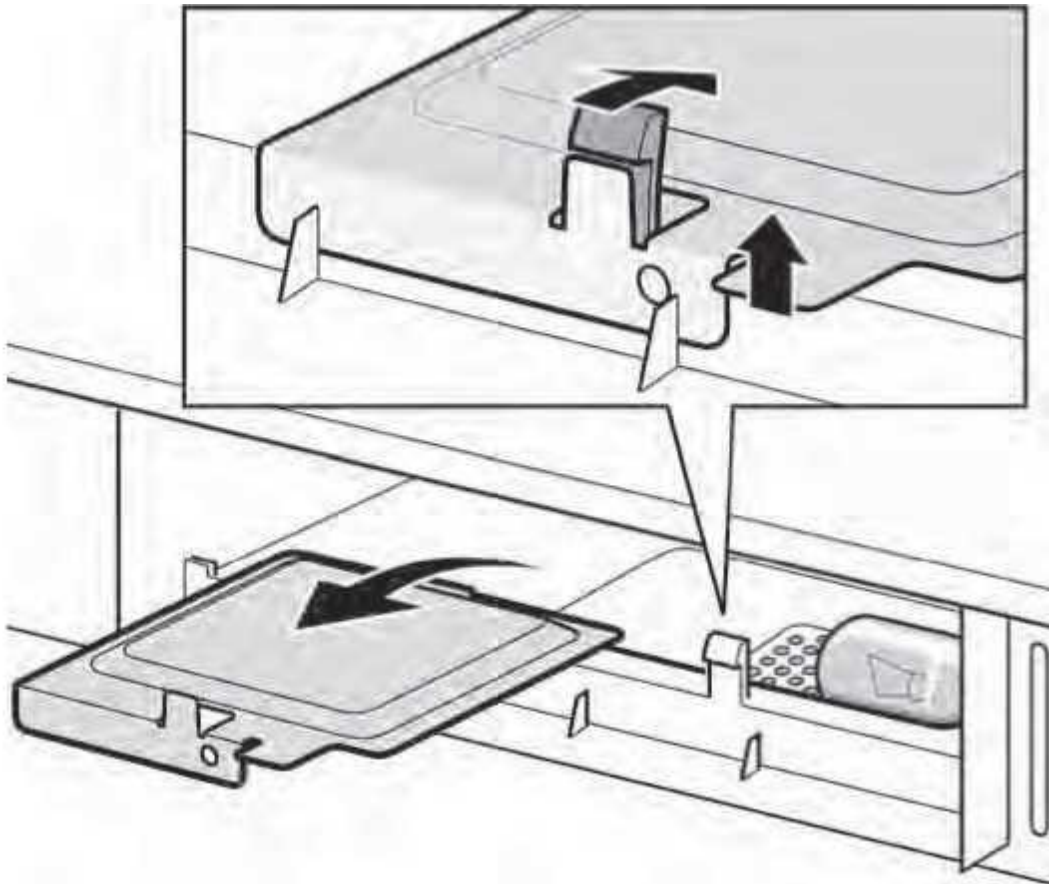

2. Remove old light bulb and replace only with equivalent 30 watt bulb available from parts distributor. Bulbs are also available at most hardware stores or lighting centers.

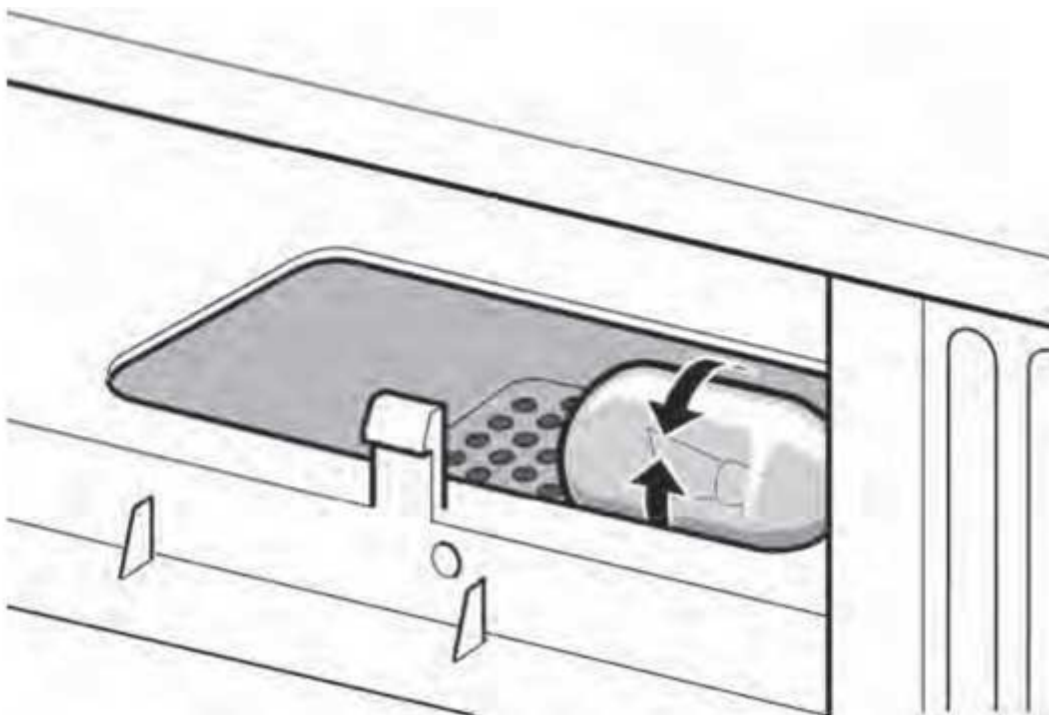

Note: DO NOT USE BULB LARGER THAN 30 WATTS.



3. Replace the microwave oven light cover by carefully pushing into place. Replace the charcoal filter. Push the vent grill back into place (engaging both the bottom and top tabs) and replace the vent grill mounting screws.

SERVICE CALL CHECK

Please check the following before calling for service:

Place one cup of water in a glass measuring cup in the microwave oven and close the door securely. Operate the microwave oven for one minute at HIGH 100%.

A Does the microwave oven light come on?	YES ____ NO ____
B Does the cooling fan work? (Put your hand on the louver above the .)	YES ____ NO ____
C Does the turntable rotate? (It is normal for the turntable to turn in either direction.)	YES ____ NO ____
D Is the water in the microwave oven warm?	YES ____ NO ____

If “NO” is the answer to any of the above questions, please check electrical outlet, fuse and/or circuit breaker. If they are functioning properly, CONTACT YOUR NEAREST ELECTROLUX AUTHORIZED SERVICER. A microwave oven should never be serviced by a “do-it-yourself” repair person.

SPECIFICATIONS

AC Line Voltage:	Single phase 120V, 60Hz, AC only
AC Power Required:	1600W 14.2 amps. (for FGMV173QF, FGMV173QB/W/Q/M)
Output Power*:	1000 W
Frequency:	2450 MHz (Class B/Group2)**
Outside Dimensions:	29 7/8”(W) x 16 13/32”(H) x 15 1/32”(D)
Cavity Dimensions:	20 15/16”(W) x 9 7/16”(H) x 14 13/32”(D)
Microwave oven Capacity***:	1.7 Cu.Ft.
Cooking Uniformity:	Turntable
Weight:	Approx. (net) 61.7 lb, (gross) 28.0 lb
Work/Night Light:	2 bulbs 30w each (incandescent light bulbs)
Oven Light:	1 bulb 30w (incandescent light bulbs)

Warning

This content is compiled from multiple sources and is provided for reference purposes only. It may not be complete or fully applicable to all situations. If you are unable to resolve your issue, please contact the product manufacturer or an authorized service provider for official support.

