

ASSEMBLY

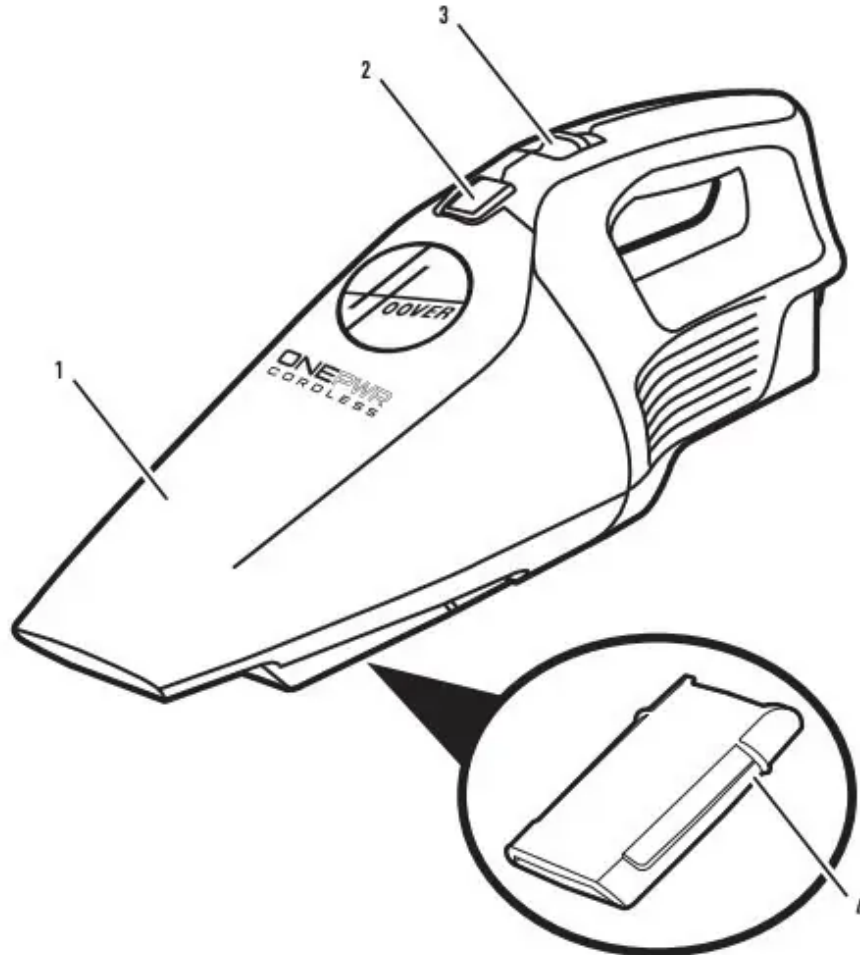

1. *Dirt cup*
2. *Release button*
3. *ON/OFF switch*
4. *Crevice tool*

WARNING Do not use this product if it is not completely assembled or if any parts appear to be missing or damaged. Use of a product with damaged or missing parts could result in serious personal injury.

WARNING! Do not attempt to modify this product or create accessories or attachments not recommended for use with this product. Any such alteration or modification is misuse and could result in a hazardous condition leading to possible serious personal injury.

If any parts are damaged or missing, please call 800-406-2005 for assistance.

OPERATION

WARNING! Do not allow familiarity with this product to make you careless. Remember that a careless fraction of a second is sufficient to inflict serious injury.

WARNING! To avoid serious personal injury, always remove the battery pack from the product when cleaning or performing any maintenance.

WARNING! Do not use any attachments or accessories not recommended by the manufacturer of this product. The use of attachments or accessories not recommended can result in serious personal injury.

Applications

You may use this product for the following purpose:

- Light-duty vacuuming of dry surfaces

Installing/Removing the Battery Pack

See Figure 1, page 8

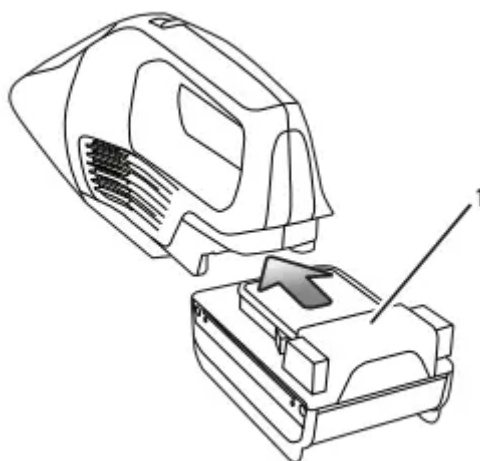

- Insert the battery pack into the battery port.
- Make sure the latches on each side of the battery pack snap into place and that the battery pack is secured in the hand vac before beginning operation.
- Locate the latches on the side of the battery pack and depress both sides to release the battery pack from the hand vac.

Charging Battery Pack

See Figure 2, page 8

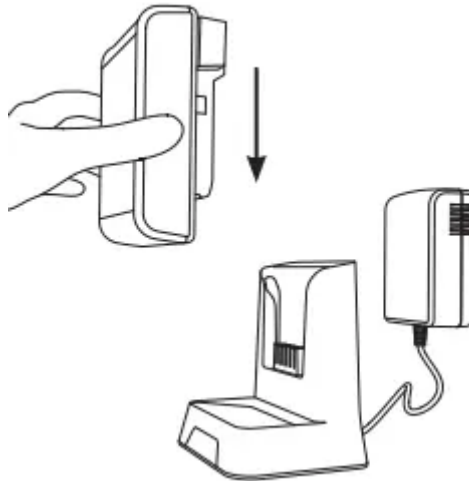

- Charge the battery fully before first use. This will take up to 3 hours. Due to federal regulations, the battery does not come fully charged.
- Plug the charger into a power outlet.
- Attach the battery pack to the charger by aligning the ribs on the battery pack to the grooves in the charger. Slide the battery pack into the charger.
- When charging, the lights on the battery will illuminate to show the state of charge. The light on the charger will flash.
- If the light on the charger flashes red, there is an error with the battery or the charger. Try again or call customer service for support.
- When charge is complete the lights on the battery will turn off and the light on the charger will be solid.
- To remove the battery pack from the charger, press the latches and pull up on the battery pack.

Starting/Stopping the Vacuum

See Figure 3, page 8

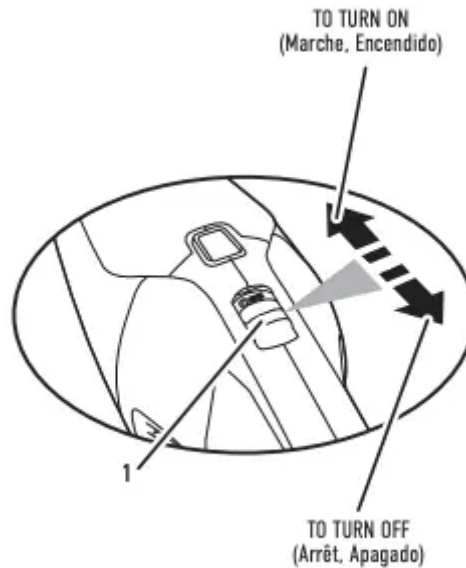

- To start the vacuum: slide the ON/OFF switch toward the front of the vacuum.
- To stop the vacuum: slide the ON/OFF switch toward the back of the vacuum.

Crevice Tool

See Figures 4 & 5, page 9

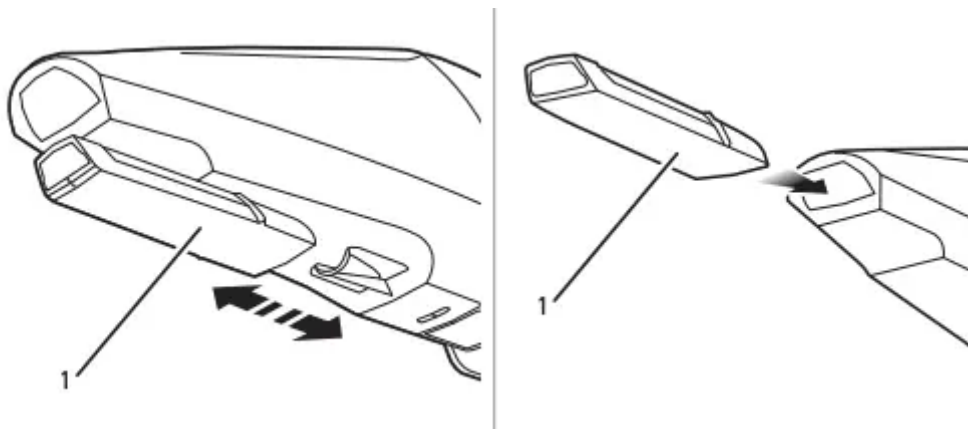

- The crevice tool is stored on the underside of the dirt cup.
- To detach the crevice tool, pull it forward and remove it from the dirt cup.
- Turn off the vacuum.
- Remove the battery pack.
- Insert the attachment into the front end of the vacuum dirt cup, making sure the attachment is firmly pushed into place.

Removing/Reattaching the Dirt Cup

See Figures 6 & 7, page 9

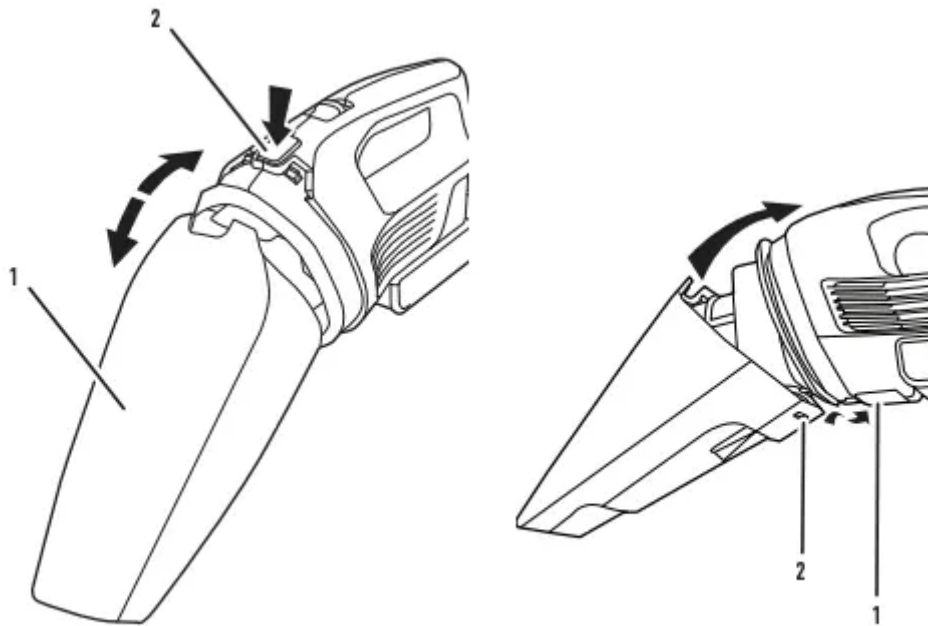

- The dirt cup should be checked, emptied, and cleaned periodically for maximum dust collection.

To remove:

- Remove the battery pack.
- Depress the release button located on top of the hand vac. Pull the dirt cup down and out.

To reattach:

- Position the two sections as shown. Align the slot on the bottom of dust bowl with the tab on the bottom of motor housing, then snap the two sections together.

MAINTENANCE

General Maintenance

Avoid using solvents when cleaning plastic parts. Most plastics are susceptible to damage from various types of commercial solvents and can be damaged by their use. Use clean cloths to remove dirt, dust, oil, grease, etc.

This product contains no serviceable parts.

If appliance is not working as it should, has been dropped, damaged, left outdoors or dropped in water, contact customer service at 800-406-2005.

WARNING! Do not at any time let brake fluids, gasoline, petroleum-based products, penetrating oils, etc., come in contact with plastic parts. Chemicals can damage, weaken or destroy plastic which could result in serious personal injury

WARNING! To avoid serious personal injury, always remove the battery pack from the product when cleaning or performing any maintenance.

Cleaning/Replacing the Filter

See Figure 8, page 9

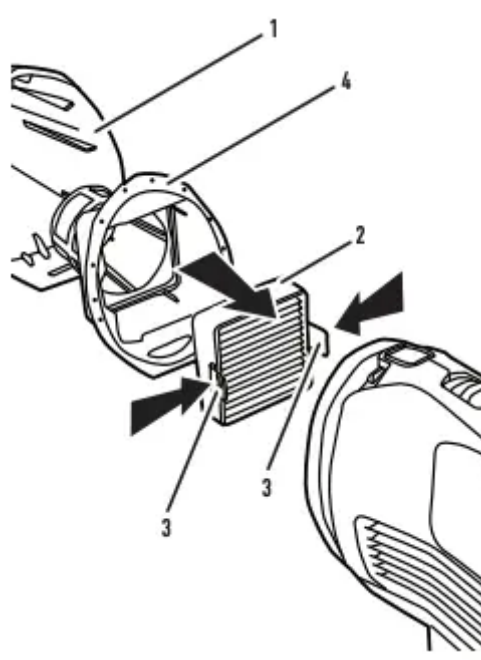

- Remove the battery pack and the dirt cup.
- Remove the filter by pressing the tabs inward and lifting the filter out of the screen assembly.
- Shake or lightly brush any dust or dirt off the filter. Replace as necessary.
- Remove the screen assembly from the dirt cup.
- Shake or lightly brush any dust off the screen and screen assembly. Wash if necessary.
- Empty the dirt cup; wash if necessary. Before reattaching to the hand vac, make sure all pieces are completely dry.

IMPORTANT SAFETY INSTRUCTIONS

SAVE THESE INSTRUCTIONS

- When using an electrical appliance, basic precautions should always be followed, including the following:

READ ALL INSTRUCTIONS BEFORE USING THIS APPLIANCE

WARNING: TO REDUCE THE RISK OF FIRE, ELECTRIC SHOCK, DAMAGE OR INJURY:

- Fully assemble before operating.
- Do not use on wet surfaces. Do not expose to rain. Store indoors.

- Dress properly. Do not wear loose clothing or jewelry.
- Contain long hair. Keep your hair, loose clothing, fingers, and all parts of the body and clothing, away from openings and moving parts. Loose clothes, jewelry, or long hair can be caught in internal moving parts.
- Turn off all controls before removing battery pack from your product.
- Do not overreach. Keep proper footing and balance at all times. Proper footing and balance enables better control of the product in unexpected situations. Do not use on a ladder or unstable support.
- Use safety equipment. Dust mask must be used for appropriate conditions.
- Do not allow to be used as a toy. Not intended for use by children age 12 and under. Close supervision is necessary when used by or near children. To avoid injury or damage, keep children away from product, and do not allow children to place fingers or other objects into any openings.
- Use only as described in this manual. Use only manufacturer's recommended attachments and products.
- To reduce the risk of fire or explosion, do not leave the product running while unattended. Immediately stop the unit if it shows signs of abnormal operation such as loss of suction, liquid or debris in the exhaust, or any abnormal motor noises.
- Do not use charger with damaged cord or plug. If appliance or charger is not working as it should, has been dropped, damaged, left outdoors, or dropped into water, call customer service at 800-406-2005.
- Do not handle charger, including charger plug, and charger terminals with wet hands.
- Do not pull or carry charger by cord, use cord as a handle, close a door on cord, or pull cord around sharp edges or corners. Do not place product on cord. Do not run appliance over cord. Keep cord away from heated surfaces.
- Do not unplug charger by pulling on cord. To unplug charger, grasp the plug, not the cord.
- Use extra care when cleaning on stairs. To avoid personal injury or damage, and to prevent the cleaner from falling, always place cleaner at bottom of stairs or on floor. Do not place cleaner on stairs or furniture, as it may result in injury or damage.
- Do not put any objects in ventilation openings. Do not use with any opening blocked. Keep openings free of dust, lint, hair, and anything that may reduce air flow.
- NEVER vacuum materials that are burning or smoking, such as hot coals, cigarette butts, matches, burning or smoking ashes, etc.
- DO NOT use to pick up flammable or combustible liquids such as gasoline, fine wood sanding, or use in areas where they may be present.
- Do not use without filter in place.

- Do not incinerate the charger, battery, or appliance even if it is severely damaged. The batteries can explode in a fire.
- The product does not have to be plugged into an electrical outlet, therefore it is always in operating condition. Be aware of possible hazards when using the product or when changing accessories.

WARNING

RISK OF FIRE, PROPERTY DAMAGE, AND INJURY. NEVER EXPOSE YOUR BATTERY PACK, CHARGER, OR UNIT TO WATER, MOISTURE, OR FLUIDS, INCLUDING BUT NOT LIMITED TO CORROSIVE OR CONDUCTIVE FLUIDS, OR ALLOW FLUIDS TO FLOW INSIDE THESE ITEMS.

Corrosive or conductive fluids, such as salt water, chlorine, certain industrial chemicals, and bleach or bleach containing products, etc., can cause a short circuit in the battery pack. If your battery pack is exposed to a corrosive or conductive fluid, do not attempt to use or charge the battery pack and immediately perform the following steps:

- Wear appropriate personal protective equipment, including eye protection and rubber gloves.
- Place your exposed battery pack in a large bucket, such as a 5 gallon or similar bucket, and fill the bucket with regular tap water. Do not place more than two packs in the bucket.
- Locate the bucket outdoors in an area inaccessible to children and pets and away from all buildings, garages/sheds, structures, vehicles, and combustible/ flammable materials.
- Leave the battery pack(s) in the bucket filled with tap water and call Customer Service at 1-800-406-2005 for additional instructions on the proper disposal of the exposed battery pack(s).
- Remove battery when the vacuum is not in use and before servicing.
- Use battery only with charger listed. For use with Hoover ONEPWR Lithium Ion Batteries, see page 7 for battery and charger compatibility.
- Recharge only with the charger specified by the manufacturer. A charger that is suitable for one type of battery pack may create a risk of fire when used with another battery pack. Do not use charger outdoors.
- Use product only with specifically designated battery packs. Use of any other battery packs may create a risk of injury and fire.
- When battery pack is not in use, keep it away from other metal objects like: paper clips, coins, keys, nails, screws, or other small metal objects that can make a connection from one terminal to another. Shorting the battery terminals together may cause sparks, burns, or a fire.

- Always remove battery pack from your product when you are assembling parts before making any adjustments, changing accessories, storing product, cleaning, or when not in use. Removing battery pack will prevent accidental starting that could cause serious personal injury.
- Do not use a battery pack or product that is damaged or modified. Damaged or modified batteries may exhibit unpredictable behavior resulting in fire, explosion or risk of injury.
- Do not store or charge battery outdoors or on wet surfaces. Do not allow to get wet.
- Do not modify or attempt to repair the appliance or the battery pack except as indicated in the instructions for use and care.
- To reduce the risk of explosion and serious personal injury, never use or expose battery pack or any cordless product in the presence of an open flame or temperatures above 265°F. An exploded battery can propel debris and chemicals. If exposed, flush with water immediately.
- Prevent unintentional starting. Ensure the switch is in the off-position before connecting to power source and/or battery pack, picking up or carrying the product. Carrying battery products with your finger on the switch or energizing battery products that have the switch on invites accidents.
- Under abusive conditions, liquid may be ejected from the battery; avoid contact. If contact accidentally occurs, flush with water. If liquid contacts eyes, additionally seek medical help. Liquid ejected from the battery may cause irritation or burns.
- Do not charge battery in a damp or wet location. Do not use, store, or charge battery packs or products in locations where the temperature is less than 50°F or more than 100°F. Do not store outside or in vehicles.
- Follow all charging instructions and do not charge the battery pack or appliance outside of the temperature range specified in the instructions. Charging improperly or at temperatures outside of the specified range may damage the battery and increase the risk of fire.
- Check for misalignment or binding of moving parts, breakage of parts, and any other condition that may affect the product's operation. If damaged, call customer service prior to use. Many accidents are caused by poorly maintained products.
- Use only accessories that are recommended by the manufacturer for your model. Accessories that may be suitable for one product may create a risk of injury when used on another product.
- Put product away after use to prevent tripping accidents.
- Do not let gasoline, oils, petroleum-based products, etc., come in contact with plastic parts. They contain chemicals that can damage, weaken, or destroy plastic.
- This product is intended for Household use only. If used Commercially warranty is VOID.

- This product contains no serviceable parts.
- Save these instructions. Refer to them frequently and use them to instruct others who may use this product. If you loan someone this product, loan them these instructions also.

CAUTION - To reduce the risk of damage:

Avoid picking up hard, sharp objects with this product, as they may cause damage.

Store appropriately indoors in a dry place. Do not expose machine to freezing temperatures.

Warning

This content is compiled from multiple sources and is provided for reference purposes only. It may not be complete or fully applicable to all situations. If you are unable to resolve your issue, please contact the product manufacturer or an authorized service provider for official support.

Document generated by [ManualsFile](#)

