

## USING YOUR OVEN

### Features

Throughout this manual, features and appearance may vary from your model.

800 Watts

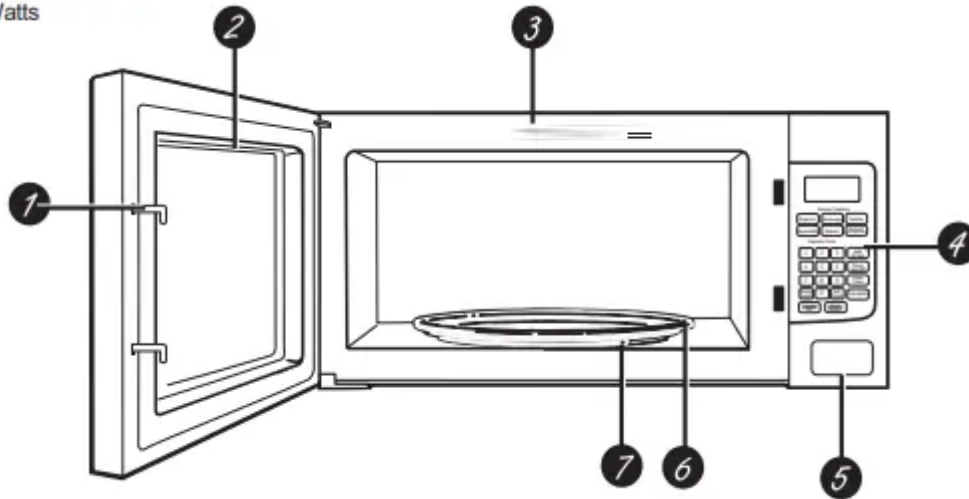

#### **1 Door Latches**

#### **2 Window with Metal Shield.**

Screen allows cooking to be viewed while keeping microwaves confined in the oven.

#### **3 Convenience Guide**

#### **4 Touch Control Panel Display**

#### **5 Door Latch Release.**

Press latch release to open door.

#### **6 Removable Turntable.**

Turntable and support must be in place when using the oven. The turntable may be removed for cleaning.

#### **7 Removable Turntable Support.**

The turntable support must be in place when using the oven. The turntable support may be removed for cleaning.

## Controls

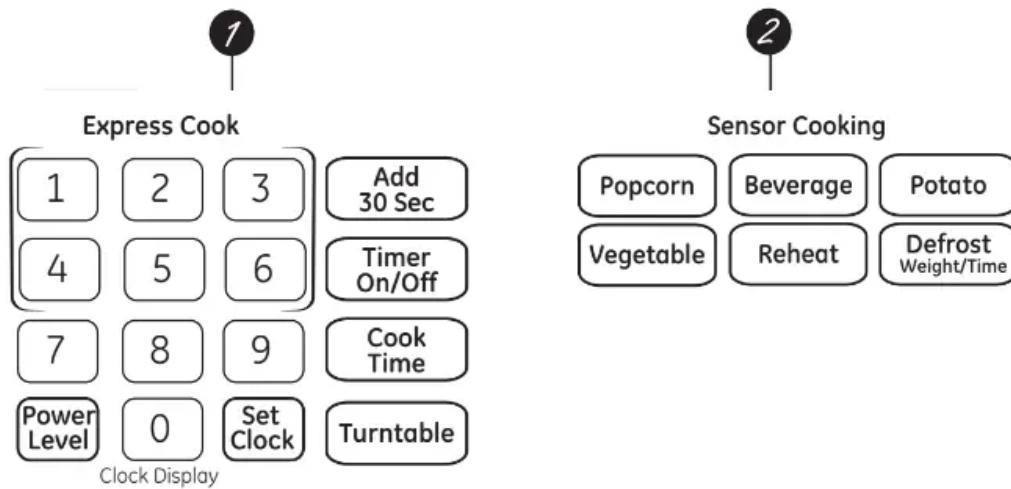

## Cooking Controls

Time Features	
Press	Enter
<b>Cook Time</b>	Amount of cooking time
<b>Defrost Weight/Time</b> Press twice	Amount of defrosting time
<b>Express Cook</b> Press number pads (1-6)	Starts Immediately!
<b>Add 30 Sec</b>	Starts Immediately!
<b>Power Level</b>	Power level 1 to 10

Convenience Features		
Press	Enter	Options
<b>Popcorn</b>	Starts immediately!	more/less time
<b>Beverage</b>	Starts immediately!	
<b>Reheat</b>	Food 1-8	more/less time
<b>Potato</b>	Starts Immediately!	more/less time
<b>Vegetables</b>	Food 1-3	more/less time
<b>Defrost Weight/Time</b> Press once	Enter food weight	

## About the features

### Power Level

The power level may be entered or changed immediately after entering the feature time for Cook Time, Time Defrost, Add 30 Sec or Express Cook. the power level may also be changed during the time countdown.

1. Press Cook Time.
2. Enter cooking or defrosting time

3. Press Power Level.
4. Select desired power level 1-10.
5. Press Start/Pause.

Variable power levels add flexibility to microwave cooking. The power levels on the microwave oven can be compared to the surface units on a range. Each power level gives you microwave energy a certain percent of the time. Power level 7 is microwave energy 70% of the time. Power level 3 is energy 30% of the time. Most cooking will be done on HI which gives you 100% power.

Power Level 10 will cook faster but food may need more frequent stirring, rotating or turning over. A lower setting will cook more evenly and need less stirring or rotating of the food.

Some foods may have better flavor, texture or appearance if one of the lower settings is used. Use a lower power level when cooking foods that have a tendency to boil over, such as scalloped potatoes.

Rest periods (when the microwave energy cycles off) give time for the food to “equalize” or transfer heat to the inside of the food. An example of this is shown with power level 3—the defrost cycle. If microwave energy did not cycle off, the outside of the food would cook before the inside was defrosted.

Here are some examples of uses for various power levels:

Power Level 10: Fish, bacon, vegetables, boiling liquids.

Power Level 7: Gentle cooking of meat and poultry; baking casseroles and reheating.

Power Level 5: Slow cooking and tenderizing for stews and less tender cuts of meat.

Power Level 3: Defrosting; simmering; delicate sauces.

Power Level 1: Keeping food warm; softening butter.

### **Cook Time I**

Allows you to microwave for any time up to 99 minutes and 99 seconds.

Power level 10 (high) is automatically set, but you may change it for more flexibility.

1. Press Cook Time.
2. Enter cooking time.
3. Change power level if you don't want full power. (Press Power Level. Select a desired power level 1–10.)
4. Press Start/Pause.

You may open the door during Cook Time to check the food. Close the door and press Start/Pause to resume cooking.

### **Cook Time II**

Lets you change power levels automatically during cooking. Here's how to do it:

1. Press Cook Time.
2. Enter the first cook time.
3. Change the power level if you don't want full power.  
(Press Power Level. Select a desired power level 1–10.)
4. Press Cook Time again.
5. Enter the second cook time.
6. Change the power level if you don't want full power.  
(Press Power Level. Select a desired power level 1–10.)
7. Press Start/Pause.

At the end of Cook Time I, Cook Time II counts down.

### **Time Defrost**

Time Defrost allows you to defrost for a selected length of time. See the Defrosting Guide for suggested times. (Weight Defrost is explained in the Auto Feature section.)

1. Press Defrost Weight/Time twice.
2. Enter defrosting time.
3. Press Start/Pause.
4. Turn food over when the oven signal.
5. Press Start/Pause.

When the oven signals, turn food over and break apart or rearrange pieces for more even defrosting. Shield any warm areas with small pieces of foil. The oven will continue to defrost if you don't open the door and turn the food.

Power level is automatically set at 3, but can be changed. You can defrost small items quickly by raising the power level after entering the time. Power level 7 cuts the total defrosting time in about half; power level 10 cuts the total time to approximately 1/3. However, food will need more frequent attention than usual. A dull thumping noise may be heard during defrosting. This is normal when oven is not operating at High power.

### **Defrosting Tips**

- Foods frozen in paper or plastic can be defrosted in the package. Closed packages should be slit, pierced or vented AFTER food has partially defrosted. Plastic storage containers should be partially uncovered.
- Family-size, prepackaged frozen dinners can be defrosted and microwaved. If the food is in a foil container, transfer it to a microwave-safe dish.

- For more even defrosting of larger foods, such as roasts, use Defrost Weight. Be sure large meats are completely defrosted before cooking.
- Foods that spoil easily should not be allowed to sit out for more than one hour after defrosting. Room temperature promotes the growth of harmful bacteria.
- When defrosted, food should be cool but softened in all areas. If still slightly icy, return to the microwave very briefly, or let it stand for a few minutes.

## **Weight Defrost**

Weight defrost automatically sets the defrosting times and power levels to give even defrosting results for meats, poultry and fish weighing up to six pounds.

1. Press Defrost Weight/Time once.
2. Using the conversion guide, enter food weight. For example, press pads 1 and 2 for 1.2 pounds (1 pound, 3 ounces).
3. Press Start/Pause.

(Time Defrost is explained in the Time Features section.)

There is a handy guide located on the inside front of the oven.

- Remove meat from package and place on microwave safe dish.
- When the oven signals, turn the food over. Remove defrosted meat or shield warm areas with small pieces of foil.
- After defrosting, most meats need to stand 5 minutes to complete defrosting. Large roasts should stand for about 30 minutes.

## **Conversion Guide**

If the weight of food is stated in pounds and ounces, the ounces must be converted to tenths (.1) of a pound.	
Ounces	Pounds
1-2	.1
3	.2
4-5	.3
6-7	.4
8	.5
9-10	.6
11	.7
12-13	.8
14-15	.9

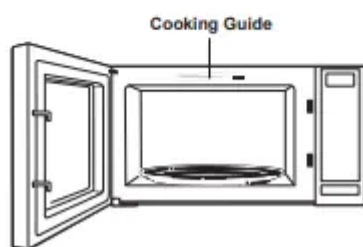

### Express Cook

This is a quick way to set cooking time for 1 –6 minutes.

Press one of the Express Cook pads (from 1 to 6) for 1 to 6 minutes of cooking at power level 10. For example, press the 2 pad for 2 minutes of cooking time.

The power level can be changed as time is counting down. Press POWER LEVEL and enter 1–10.

### Add 30 Sec

You can use this feature two ways:

- It will add 30 seconds to the time counting down each time the pad is pressed.
- It can be used as a quick way to set 30 seconds of cooking time.

### Humidity Sensor

The Sensor Features detect the increasing humidity released during cooking. The oven automatically adjusts the cooking time to various types and amounts of food.

Do not use the Sensor Features twice in succession on the same food portion—it may result in severely overcooked or burnt food. Be sure to let the oven cool down for 5-10 minutes before starting the next sensor cook.

If food is undercooked after the countdown, use Cook Time for additional cooking time.

- The proper containers and covers are essential for best sensor cooking.

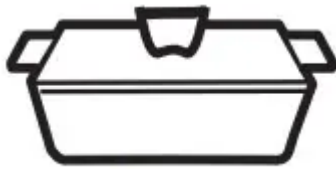

**Covered**

- Always use microwave safe containers and cover them with lids or vented plastic wrap. Never use tight sealing plastic containers they can prevent steam from escaping and cause food to overcook.



**Vented**

- Be sure the outside of the cooking containers and the inside of the microwave oven are dry before placing food in the oven. Beads of moisture turning into steam can mislead the sensor.



**Dry off dishes so they don't mislead the sensor.**

## **Microwave Terms**

### **Arcing**

Arcing is the microwave term for sparks in the oven. Arcing is caused by:

- metal or foil touching the side of the oven.
- foil that is not molded to food (upturned edges act like antennas).
- metal such as twist-ties, poultry pins, gold-rimmed dishes.
- recycled paper towels containing small metal pieces.
- plates or dishes with a metallic trim or glaze with a metallic sheen.

### **Covering**

Covers hold in moisture, allow for more even heating and reduce cooking time. Venting plastic wrap or covering with wax paper allows excess steam to escape.

### **Shielding**

In a regular oven, you shield chicken breasts or baked foods to prevent over-browning. When microwaving, you use small strips of foil to shield thin parts, such as the tips of wings and legs on poultry, which would cook before larger parts.

### **Standing Time**

When you cook with regular ovens, foods such as roasts or cakes are allowed to stand to finish cooking or to set. Standing time is especially important in microwave cooking. Note that a microwaved cake is not placed on a cooling rack.

### **Venting**

After covering a dish with plastic wrap, you vent the plastic wrap by turning back one corner so excess steam can escape.

## **Care and Cleaning**

### **Helpful Hints**

An occasional thorough wiping with a solution of baking soda and water keeps the inside fresh. Be certain the oven control is turned off before cleaning any part of this oven.



### **How to Clean the Inside**

#### **Walls, Floor, Inside Window, Metal and Plastic Parts on the Door**

Some spatters can be removed with a paper towel; others may require a damp cloth. Remove greasy spatters with a sudsy cloth, then rinse with a damp cloth. Do not use abrasive cleaners or sharp utensils on oven walls.

To clean the surface of the door and the surface of the oven that come together upon closing, use only mild, nonabrasive soaps or detergents using a sponge or soft cloth. Rinse with a damp cloth and dry.

Never use a commercial oven cleaner on any part of your microwave.

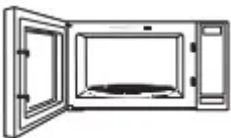

### **Removable Turntable and Turntable Support**

To prevent breakage, do not place the turntable into water just after cooking. Wash it carefully in warm, sudsy water or in the dishwasher. The turntable and support can be broken if dropped. Remember, do not operate the oven in the microwave mode without the turntable and support seated and in place.



## **How to Clean the Outside**

Do not use cleaners containing ammonia or alcohol on the microwave oven. Ammonia or alcohol can damage the appearance of the microwave.

### **Case**

Clean the outside of the microwave with a sudsy cloth. Rinse with a damp cloth and then dry. Wipe the window clean with a damp cloth.

### **Control Panel and Door**

Wipe with a damp cloth. Dry thoroughly. Do not use cleaning sprays, large amounts of soap and water, abrasives or sharp objects on the panel—they can damage it. Some paper towels can also scratch the control panel.

### **Door Surface**

It is important to keep the area clean where the door seals against the microwave. Use only mild, non-abrasive detergents applied with a clean sponge or soft cloth. Rinse well.

### **Power Cord**

If the cord becomes soiled, unplug and wash with a damp cloth. For stubborn spots, sudsy water may be used, but be certain to rinse with a damp cloth and dry thoroughly before plugging cord into outlet.

### **Stainless Steel (on some models)**

Do not use a steel-wood pad; it will scratch the surface.

To clean the stainless steel surface, use a hot, damp cloth with a mild detergent suitable for stainless steel surfaces. Use a clean, hot, damp cloth to remove soap. Dry with a dry, clean cloth. Always scrub lightly in the direction of the grain.

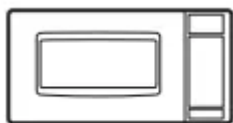

## Troubleshooting Tips

### OVEN WILL NOT COME ON

- A fuse in your home may be blown or the circuit breaker tripped. Replace fuse or reset circuit breaker.
- Unplug your microwave oven, then plug it back in.
- Make sure 3-prong plug on oven is fully inserted into wall receptacle.

### CONTROL PANEL LIGHTED, YET OVEN WILL NOT START

- Door not securely closed.
- Start/Pause must be pressed after entering cooking selection.
- Another selection entered already in oven and Cancel/Off not pressed to cancel it.
- Make sure you have entered cooking time after pressing Cook Time.
- Cancel/Off was pressed accidentally. Reset cooking program and press Start/Pause.
- Make sure you entered food weight after pressing Defrost Weight.
- Oven was paused accidentally. Press Start/Pause to restart the cooking program.

### “ERR” APPEARS ON DISPLAY

- During a Sensor Cooking program, the door was opened before steam could be detected. “ERR” will display until Cancel/Off is pressed.
- Steam was not detected in maximum time. Use Cook Time to heat for more time.

### “LOC” APPEARS ON DISPLAY

- The control panel has been locked. (When the control panel is locked, “LOC” will be displayed.) Press and hold Cancel/Off for about 3 seconds to unlock the control panel.

### FOOD AMOUNT TOO LARGE FOR SENSOR REHEAT

- Sensor Reheat is for single servings of recommended foods. Use Cook Time for large amounts of food.

### “FOOD” APPEARS ON DISPLAY

- The control detected that the door has not been opened (food/beverage has not been placed inside).

### “PF” APPEARS ON DISPLAY

- A Power Failure has occurred. Press Cancel/Off to clear the display.

### “F3” APPEARS ON DISPLAY

- A key has been activated for more than 60 seconds. Press Cancel/Off to clear the display. This can happen if liquid is on the control panel. Dry the control panel thoroughly after cleaning.

## Things That Are Normal With Your Microwave Oven

- Steam or vapor escaping from around the door.
- Light reflection around door or outer case.
- Dimming oven light and change in the blower sound at power levels other than high.
- Dull thumping sound while oven is operating.
- TV/radio interference might be noticed while using the microwave. Similar to the interference caused by other small appliances, it does not indicate a problem with the microwave. Plug the microwave into a different electrical circuit, move the radio or TV as far away from the microwave as possible, or check the position and signal of the TV/radio antenna

### Warning

This content is compiled from multiple sources and is provided for reference purposes only. It may not be complete or fully applicable to all situations. If you are unable to resolve your issue, please contact the product manufacturer or an authorized service provider for official support.