

## Description

### General Description

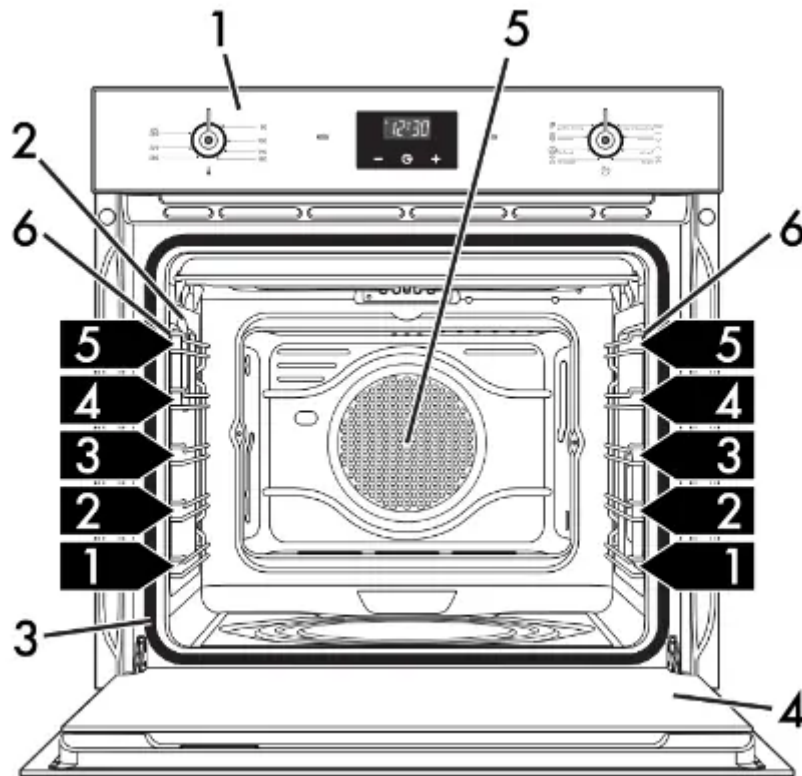

- 1. Control panel
- 2. Oven light
- 3. Seal
- 4. Door
- 5. Fan
- 6. Rack/tray support frames

**1,2,3...** Frame shelf



## Control panel

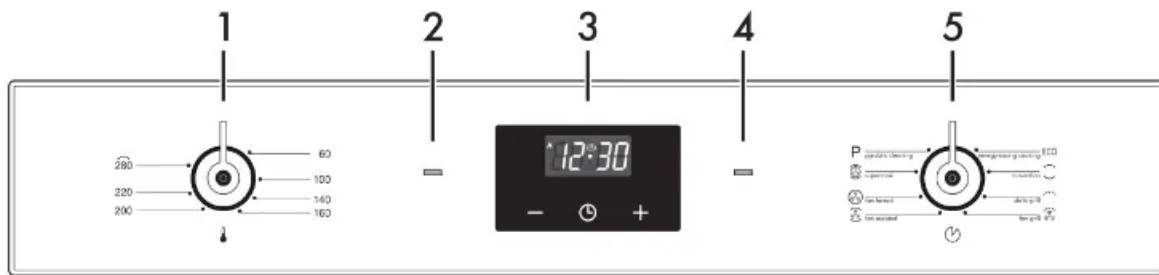

### 1. Temperature knob

- This knob allows you to select the cooking temperature. Turn the knob clockwise to the required value, between the minimum and maximum settings.

### 2. Thermostat indicator light

- The indicator light comes on to indicate that the oven is heating up. It turns off as soon as it reaches the set temperature. It flashes regularly to indicate that the temperature setting is kept constant inside the oven.

### 3. “Touch” Programmer clock

- Useful for displaying the current time, setting programmed cooking operations, and programming the minute minder timer.

### 4. Door lock indicator light

- It comes on when the automatic cleaning cycle (pyrolytic cleaning) is activated.

### 5. Function knob

- The oven's various functions are suitable for different cooking modes. After selecting the required function, set the cooking temperature using the temperature knob.

## Other parts

### Shelves

The appliance features shelves for positioning trays and racks at different heights. The insertion heights are indicated from the bottom upwards (see General Description).

### Cooling fan

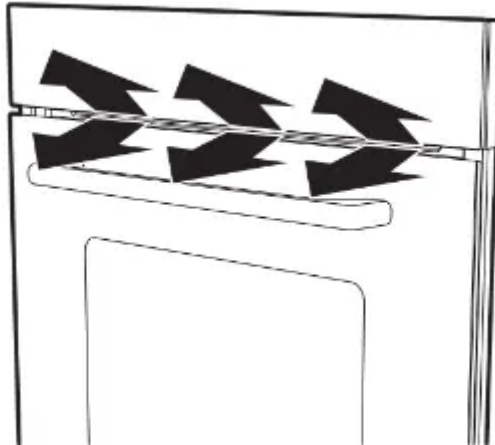

The fan cools the oven and comes into operation during cooking. The fan causes a steady outflow of air from above the door which may continue for a brief period of time even after the appliance has been turned off.

### Interior lighting

The appliance's interior lighting comes on:

- When the door is opened.
- When any function is selected, apart from the ECO **ECO** and Pyrolytic **P** functions.

When the door is open, it is not possible to turn off the interior lighting.

### Available accessories

#### Tray

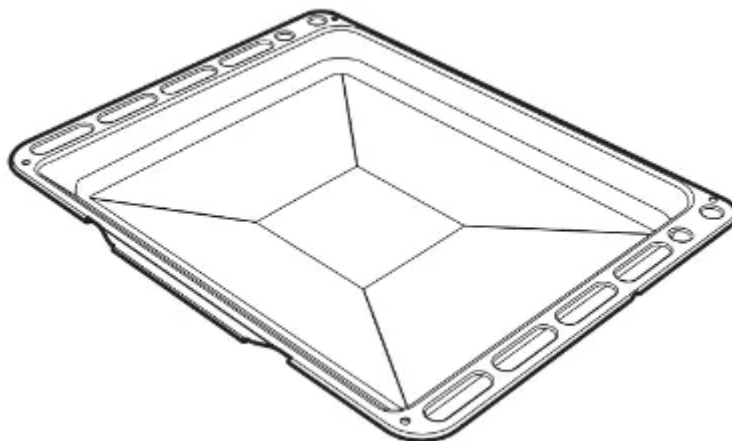

Useful for collecting fat from foods placed on the rack above and for cooking pies, pizzas, and baked desserts.

#### Tray rack

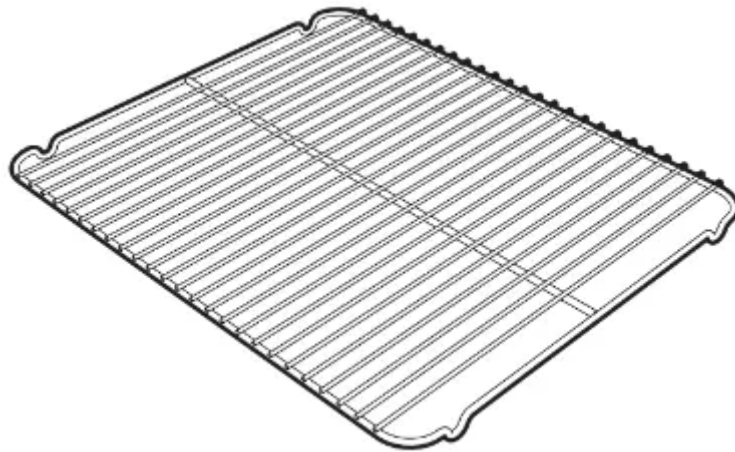

To be placed over the top of the oven tray; for cooking foods that may drip.

**Rack**

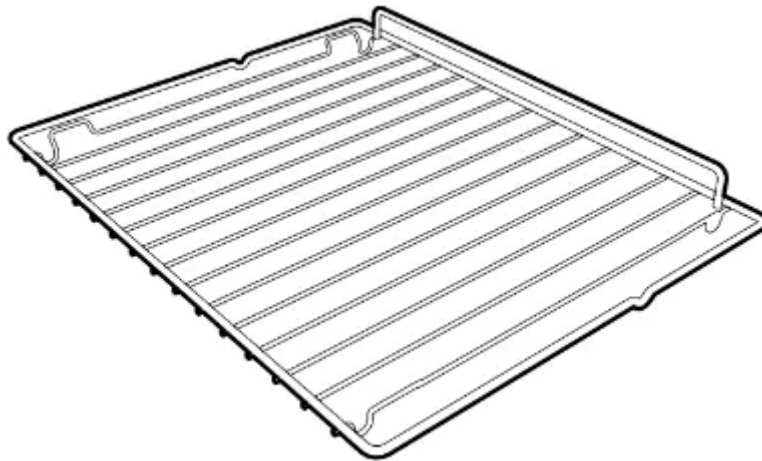

Used for supporting containers with food during cooking.

Some models are not provided with all accessories.

The oven accessories intended to come into contact with food are made of materials that comply with the provisions of current legislation.

Original supplied and optional accessories can be requested from Authorized Assistance Centres.

Use only original accessories supplied by the manufacturer.



# Use

## Instructions

### High temperature inside the oven during use. Danger of burns

- Keep the oven door closed during cooking.
- Protect your hands by wearing heat-resistant gloves when moving food inside the oven.
- Do not touch the heating elements inside the oven.
- Do not pour water directly onto very hot trays.
- Do not allow children to get near the oven when it is in operation.

### High temperature inside the oven during use. The danger of fire or explosion

- Do not spray any spray products near the oven.
- Do not use or leave flammable materials near the oven.
- Do not use plastic kitchenware or containers when cooking food.
- Do not put sealed tins or containers in the oven.
- Do not leave the oven unattended during cooking operations where fats or oils could be released.
- Remove all trays and racks which are not required during cooking.

### Improper use. Risk of damage to enameled surfaces

- Do not cover the bottom of the oven cavity with aluminum or tin foil sheets.
- If you wish to use greaseproof paper, place it so that it will not interfere with the hot air circulation inside the oven.
- Do not place pans or trays directly on the bottom of the oven cavity.
- Do not pour water directly onto very hot trays.

## First use

1. Remove any protective film from the outside or inside of the appliance, including accessories.
2. Remove any labels (apart from the technical data plate) from the accessories and from the oven cavity.
3. Remove and wash all the appliance accessories (see Cleaning and maintenance).
4. Heat the empty oven at the maximum temperature to burn off any residues left by the manufacturing process.

## Using the accessories

### Racks and trays

Racks and trays have to be inserted into the side guides until they come to a complete stop.

- The mechanical safety locks that prevent the rack from being removed accidentally must face downwards and towards the back of the oven cavity.

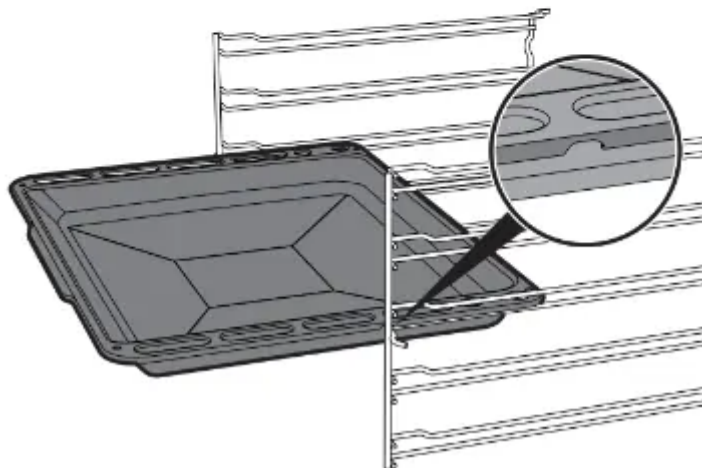
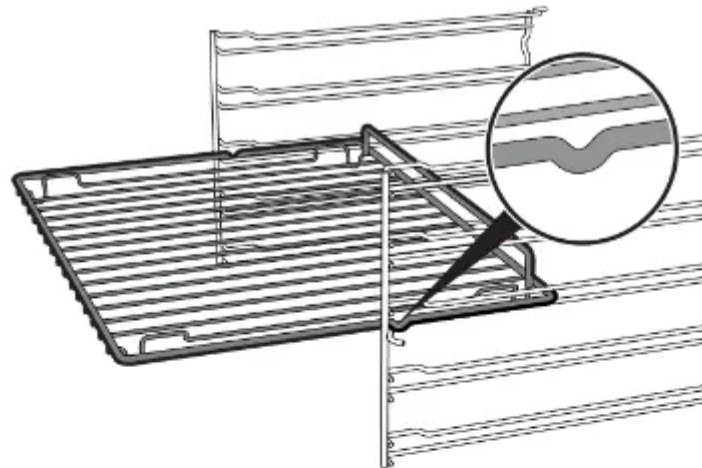

Carefully insert the racks and trays as far as they will go into the oven cavity.

Clean the trays before using them for the first time to remove any residues left by the manufacturing process.

### Tray rack

The tray rack has to be inserted into the tray. In this way, fat can be collected separately from the food that is being cooked.

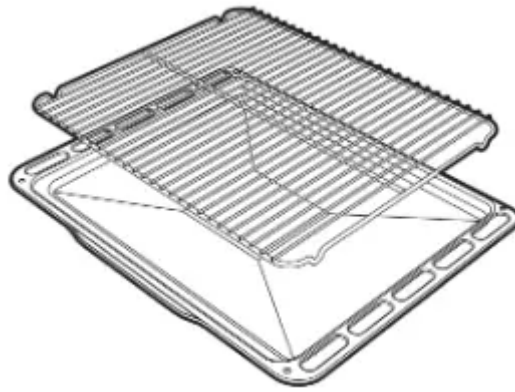



## Using the oven

### Switching on the oven

To switch on the oven:

1. Select the cooking function using the function knob.
2. Select the temperature using the temperature knob.

Regular flashing of the thermostat indicator light during cooking is normal and indicates that the temperature is being maintained constant inside the oven.

Ensure that the programmer clock shows the cooking duration symbol , otherwise it will not be possible to turn on the oven. Press the key  to reset the programmer clock.

### Functions list

#### **ECO (Energy-saving cooking)**

This low energy consumption function is particularly suitable for cooking on a single shelf. Ideal when cooking meat, fish, and vegetables. It is not recommended for foods that require proof. For greater energy savings and to reduce the time required, it is recommended to put foods in the oven cavity without preheating them.

When using the ECO function, avoid opening the oven door during cooking.

When using the ECO function, cooking times (and pre-heating, if used) are longer.

#### **Convection**

As the heat comes from above and below at the same time, this system is particularly suitable for certain types of food. Traditional cooking, also known as static cooking, is suitable for cooking just

one dish at a time. Perfect for all types of roasts, bread, and cakes and in any case particularly suitable for fatty meats such as goose and duck.



### **Static grill**

The heat coming from the grill element gives perfect grilling results above all for thin and medium-thickness

meat and in combination with the rotisserie (where fitted) gives the food an even browning at the end of

cooking. Perfect for sausages, spare ribs, and bacon. This function enables large quantities of food, particularly meat, to be grilled evenly.



### **Fan grill**

The air produced by the fan softens the strong heatwave generated by the grill, grilling perfectly even very thick foods. Perfect for large cuts of meat (e.g. pork hock).



### **Fan assisted**

The operation of the fan, combined with traditional cooking, ensures consistent cooking even with complex recipes. Perfect for biscuits and cakes, even when simultaneously cooked on several levels. (For multiple-level cooking, we recommend using the 2<sup>nd</sup> and 4<sup>th</sup> shelf).



### **Fan forced**

The combination of the fan and the circular heating element (incorporated in the rear of the oven) allows you to cook different foods on several levels, as long as they need the same temperatures and the same type of cooking. Hot air circulation ensures instant and even distribution of heat. It will be possible, for instance, to cook fish, vegetables, and biscuits simultaneously (on different levels) without odors and flavors mingling.



### **Supercook**

The combination of fan-assisted cooking and traditional cooking allows different foods to be cooked on several levels extremely quickly and efficiently, without odors and flavors mingling.

Perfect for large volumes that call for intense cooking. (For multiple-level cooking, we recommend using the 1<sup>st</sup> and 4<sup>th</sup> shelves.)

## **P** Pyrolytic cleaning

Setting this function, the oven reaches temperatures up to 500°C, destroying all the grease which forms on the internal walls.

### **Cooking advice**

#### **General advice**

- Use a fan-assisted function to achieve consistent cooking at several levels.
- It is not possible to shorten cooking times by increasing the temperature (the food could be overcooked on the outside and undercooked on the inside).

#### **Advice for cooking meat**

- Cooking times vary according to the thickness and quality of the food and to consumer taste.
- Use a meat thermometer when roasting meat, or simply press on the roast with a spoon. If it is hard, it is ready; If not, it needs another few minutes of cooking.

#### **Advice for cooking with the Grill and the Fan grill**

- Meat can be grilled even when it is put into the cold oven or into the preheated oven if you wish to change the effect of the cooking.
- With the Fan grill function, we recommend that you preheat the oven before grilling.
- We recommend placing the food at the center of the rack.
- With the Grill function, we recommend that you turn the temperature knob to the



maximum value near the symbol to optimize cooking.

#### **Advice for cooking desserts/pastries and biscuits**

- Use dark metal molds: They help to absorb the heat better.
- The temperature and the cooking time depend on the quality and consistency of the dough.
- To check whether the dessert is cooked right through: At the end of the cooking time, put a toothpick into the highest point of the dessert. If the dough does not stick to the toothpick, the dessert is cooked.
- If the dessert collapses when it comes out of the oven, on the next occasion reduce the set temperature by about 10°C, selecting a longer cooking time if necessary.

## Advice for defrosting and proving

- Place frozen foods without their packaging in a lidless container on the first shelf of the oven.
- Avoid overlapping the food.
- To defrost meat, use the rack placed on the second level and a tray on the first level. In this way, the liquid from the defrosting food drains away from the food.
- The most delicate parts can be covered with aluminum foil.
- For successful proving, a container of water should be placed in the bottom of the oven.

## To save energy

- Stop cooking a few minutes before the time normally used. Cooking will continue for the remaining minutes with the heat which has accumulated inside the oven.
- Reduce any opening of the door to a minimum to avoid heat dispersal.
- Keep the inside of the appliance clean at all times.

## “Touch” Programmer clock

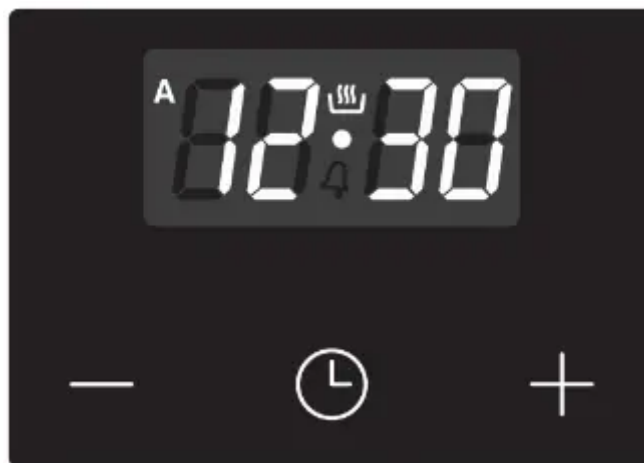

Value decrease key



Clock key



Value increase key





Ensure that the programmer clock shows the cooking duration symbol , otherwise it will not



be possible to turn on the oven. Press the key  to reset the programmer clock.

## Setting the time











If the time is not set, the oven will not switch on.

On the first use, or after a power failure, the digits  will be flashing on the appliance's display.

1. Hold down the clock key  for two seconds. The dot between the hours and the minute's flashes.
2. The time can be set via the value increase key  and value decrease key . Keep the key pressed in to increase or decrease rapidly.
3. Wait 7 seconds. The dot between the hours and the minutes stops flashing.
4. The symbol  on the display indicates that the appliance is ready to start cooking.



To change the time, hold down the value increase key  and value decrease key  at the same time for two seconds, then set the time.

## Timed cooking

1. Keep the clock key  pressed until the symbol  appears.
2. Press the clock key  again. On the display the symbol  and the text  appear, alternating with the current time.
3. Use the value increase  and value decrease  keys to set the required minutes of cooking.
4. Select a function and a cooking temperature.
5. Wait approx. 5 seconds without pressing any key in order for the function to activate. The current time and the symbols  and  will appear on the display. At the end of cooking the heating elements will be deactivated. On the display, the symbol  turns off, the symbol  flashes, and the buzzer sound.
6. To turn the buzzer off, simply press one of the programmer clock keys.

















7. Press the clock key  to reset the programmer clock.

It is not possible to set a cooking time of more than 10 hours.

To cancel the set programming press and hold down the value increase  and the value decrease  keys at the same time and then turn the oven off manually.

### Programmed cooking



Programmed cooking is the function that allows a cooking operation to be started at a set time and then ended after a specific length of time set by the user.

1. Set the cooking time as described in the previous point "Timed cooking".
2. Hold the menu key  down for 2 seconds.
3. Press the menu key  again. The display will show the digits  and the text  in sequence, while the  symbol flashes (for example, the current time is 17:30)
4. Use the  or  key to set the required minutes (for example 1 hour)
5. Press the menu key . The text  will appear on the display in sequence with the pre-set cooking duration added to the current time (for example, the cooking end time shown is 18:30).
6. Press the  or  key to set the cooking end time. (for example, 19:30).
  - Bear in mind that a few minutes for oven preheating must be added to the cooking time.
7. Wait approx. 7 seconds without pressing any key in order for the function to activate. The current time will appear on the display, and the symbols  and  will turn off while the  indicator light comes on.
8. Select a cooking temperature and function.
9. At the end of cooking the heating elements will be deactivated. On the display, the symbol  turns off, the symbol  flashes, and the buzzer sound.

10. Return the function and temperature knobs to **0**.

11. To turn off the buzzer just press any key of the programmer clock.



12.

Press the keys  and  at the same time reset the set program.

It is not possible to set a cooking time of more than 10 hours.

It is not possible to set a programmed cooking time of more than 24 hours.

After setting, hold the menu key  down for 2 seconds to display the cooking time remaining.

Press the menu key  again. The display shows the text  and the remaining cooking time in sequence.

### Minute minder timer

The minute minder timer does not stop the cooking operation but rather informs the user when the set time has run out.



The minute minder timer can be activated at any time.

1.



Keep the clock key  pressed for a few seconds. The display shows the figures

 and the symbol  flashing between the hours and minutes.

2.

Use the value increase  and value decrease  keys to set the number of minutes required.

3. Wait for approx. 5 seconds without pressing any key to finish setting the minute minder.

The current time and the symbols  and  appear on the display. A buzzer will sound when the set time is reached.

4.

Press the value decrease key  to turn the buzzer off.



The minute minder timer can be set from 1 minute to a maximum of 23 hours and 59 minutes.

### Modifying the set data



1.

Press the clock key .

2.





Use the value increase  and value decrease  keys to set the number of minutes required.

## Deleting the set data

1. Press the clock key .
2. Hold down the value increase  and value decrease  keys at the same time.
3. Then switch off the oven manually if cooking is in progress.

## Selecting the buzzer

The buzzer can have 3 tones.

1. Hold down the value increase  and value decrease  keys at the same time.
2. Press the clock key .
3. Press the value decrease key  to select a different buzzer tone.

# Cleaning and maintenance

## Instructions

### Improper use

#### Risk of damage to surfaces

- Do not use steam jets to clean the appliance.
- Do not use cleaning products containing chlorine, ammonia, or bleach on steel parts or parts with metallic finishes on the surface (e.g. anodizing, nickel- or chromium-plating).
- Do not use abrasive or corrosive detergents on glass parts (e.g. powder products, stain removers, and metallic sponges).
- Do not use rough or abrasive materials or sharp metal scrapers.

## Cleaning the appliance

To keep the surfaces in good condition, they should be cleaned regularly after use. Let them cool first.

We recommend the use of cleaning products distributed by the manufacturer.

### Ordinary daily cleaning

Always use only specific products that do not contain abrasives or chlorine-based acids.

Pour the product onto a damp cloth and wipe the surface, rinse thoroughly and dry with a soft cloth or a microfibre cloth.

### Food stains or residues

Do not use steel sponges or sharp scrapers as they will damage the surfaces.

Use ordinary non-abrasive products with the aid of wooden or plastic utensils if necessary. Rinse thoroughly and dry with a soft cloth or a microfibre cloth.

Do not allow residues of sugary foods (such as jam) to be set inside the oven. If left to set for too long, they might damage the enamel lining of the oven.

## Cleaning the door

### Removing the door

For easier cleaning, the door can be removed and placed on a canvas.

To remove the door proceed as follows:

1. Open the door completely and insert two pins into the holes on the hinges indicated in

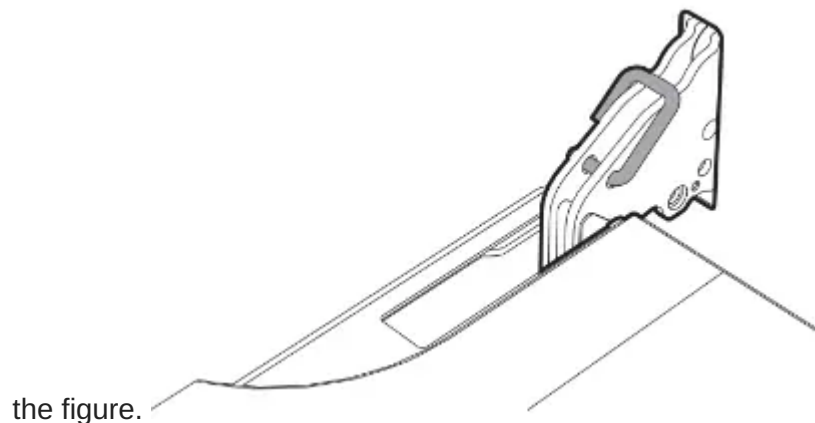

2. Grasp the door on both sides with both hands, lift it forming an angle of around 30° and

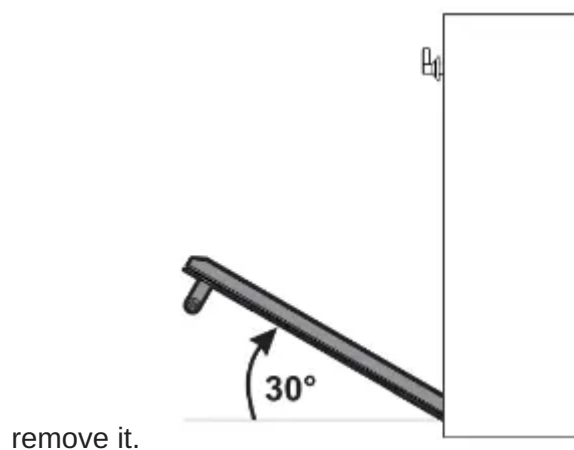

3. To reassemble the door, put the hinges in the relevant slots in the oven, making sure that grooved sections **A** are resting completely in the slots. Lower the door and once it is in

place remove the pins from the holes in the hinges.

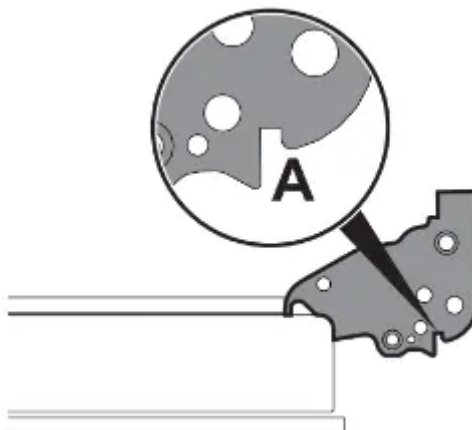

### Cleaning the door glazing

The glass in the door should always be kept thoroughly clean. Use absorbent kitchen roll. In case of stubborn dirt, wash with a damp sponge and an ordinary detergent.

We recommend the use of cleaning products distributed by the manufacturer.

### Removing the internal glass panels

For easier cleaning, the internal glass panels of the door can be removed.

1. Remove the internal glass panel by pulling the rear part gently upwards, following the movement indicated by the arrows (1).
2. Then, pull the front part upwards (2). In this way, the 4 pins attached to the glass are released from their seats in the oven door.

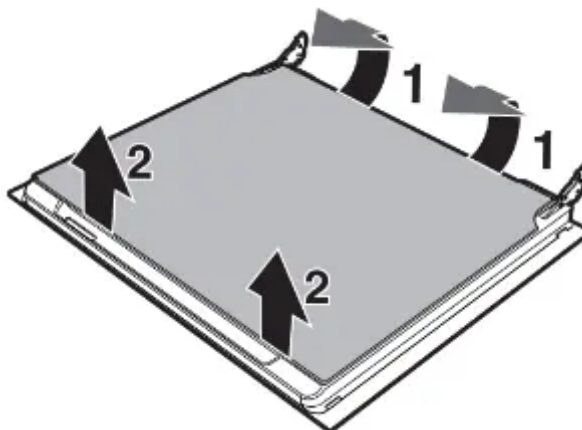

3. Some models have an intermediate glass panel. Remove the intermediate glass panel

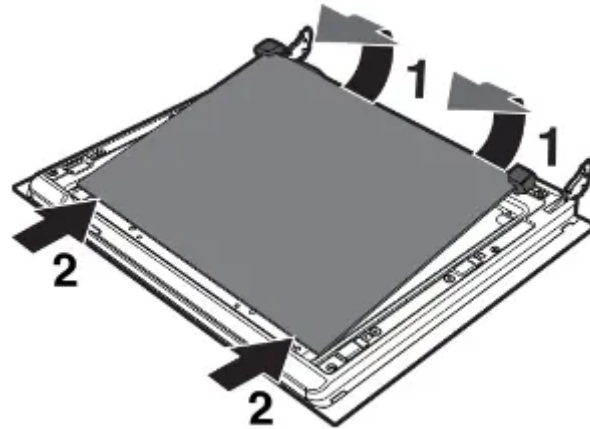

by lifting it upwards.

4. Clean the external glass panel and the panels were removed previously. Use absorbent kitchen roll. In case of stubborn dirt, wash with a damp sponge and a neutral detergent.

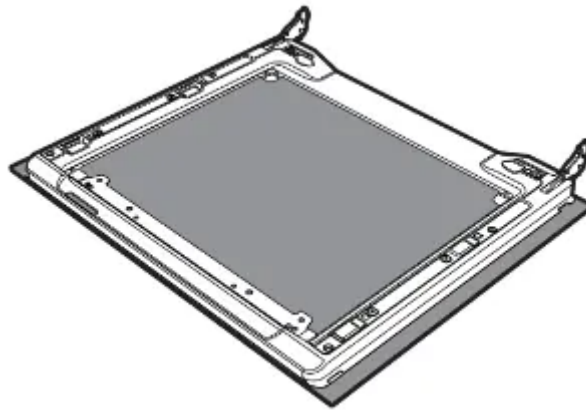

5. Refit the panels in the reverse order in which they were removed.
6. Reposition the internal glass panel. Take care to center and secure the 4 pins into their seats in the oven door by applying slight pressure.

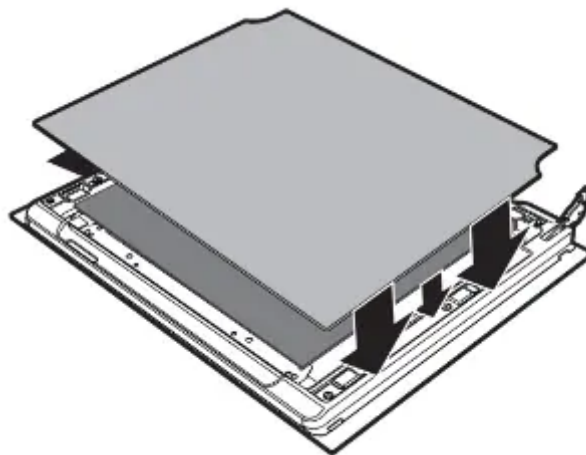

## Cleaning the inside of the oven

### Advice for cleaning the oven cavity

In order to keep your oven in the best possible condition, clean it regularly after letting it cool down. Do not allow food residues to dry inside the oven cavity because doing so could damage the enamel.

Before cleaning, remove all the parts that can be removed.

For easier cleaning, it is recommended to remove:

- The door;
- The rack/tray support frames;
- The seal.

The oven should be operated at the maximum temperature for about 15-20 minutes after the use of specific products, to burn off the residues left inside the oven.

For easier cleaning, remove the door.

### Removing the rack/tray support frames

Removing the rack/tray support frames enables the sides to be cleaned more easily. This operation should be performed each time the automatic cleaning cycle is used (on some models only).

Removing the rack/tray support frames:

1. Pull the frame towards the inside of the oven cavity to unhook it from its groove **A**.
2. Then slide it out of the seats on the back **B**.
3. When cleaning is complete, repeat the above procedures to replace the rack/ tray

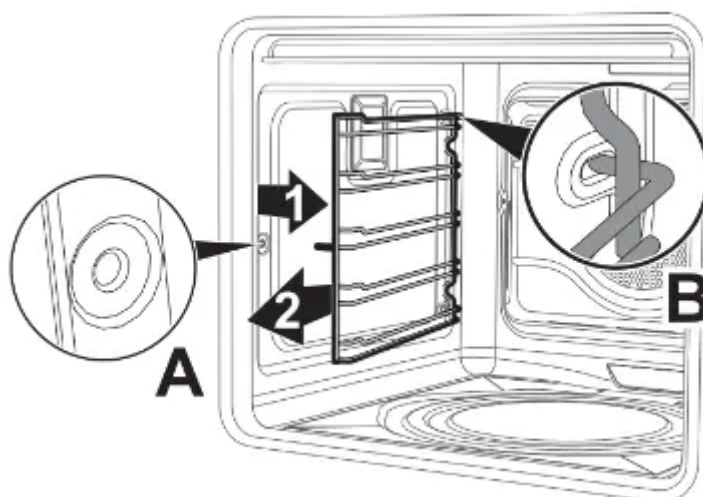

support frames.

### Pyrolytic

The pyrolytic cycle is an automatic high-temperature cleaning procedure that causes dirt to dissolve. Thanks to this process, it is possible to clean the oven cavity very easily.

## Improper use

### Risk of damage to surfaces



- Remove any food residues or large spills from previous cooking operations from the oven cavity.
- Switch off the burners or hot plates of the cooktop installed above the oven.

### Preliminary operations

Before starting the Pyrolytic cycle:

- Clean the internal glass panel following the usual cleaning instructions.
- For very stubborn encrustations spray an oven cleaning product onto the glass (read the warnings on the product); leave for 60 minutes, then rinse and dry the glass using a kitchen roll or a microfibre cloth.
- Completely remove all accessories from inside the oven.
- Remove the rack/tray support frames.
- Close the door.

### Setting the Pyrolytic cycle

1. Turn the function knob to the symbol  pyrolytic cleaning function.
2. The duration of the Pyrolytic cycle will appear on the display.
3. Use the value increase  or value decrease  keys to set the duration of the Pyrolytic cycle from a minimum of 2 hours to a maximum of 3 and a half hours.
  - Recommended pyrolytic cycle duration:
    - Light dirt: 2 hours.
    - Medium dirt: 2 1/2 hours.
    - Heavy dirt: 3 hours.
4. After selecting the pyrolysis cycle duration, the thermostat indicator light starts to flash and the oven starts to heat up (approx. 5 seconds after the last intervention by the user).
5. One minute after the pyrolysis cycle has started the door is locked (the door lock indicator light comes on) by a device that prevents the door from being opened.
  - It is not possible to select any function once the door lock device has been activated.
6. At the end of the pyrolysis cycle, all the numbers will flash and a buzzer will sound to indicate the end of the automatic cleaning cycle.

7. Return the function knob to the **O** position.
8. The door remains locked as long as the temperature inside the oven returns to safety levels (the door lock indicator light comes off).
9. Wait for the oven to cool down and collect the residues deposited inside with a damp microfibre cloth.





During the first Pyrolytic cycle, unpleasant odors may occur due to the normal evaporation of oily substances used during manufacturing. This is absolutely normal and disappears after the first Pyrolytic cycle.

During the Pyrolytic cycle, the fans are louder due to a greater speed of rotation. This is an absolutely normal operation, intended to provide more effective heat dispersal. At the end of the Pyrolytic cycle, the fans will continue to operate for long enough to prevent overheating the sides of adjacent units and the front of the oven.

If the Pyrolytic cycle gives unsatisfactory results at a minimum duration, it is recommended to set a longer time for subsequent cleaning cycles.

### Setting a programmed Pyrolytic cycle

It is possible to program the pyrolytic cycle start time just like any other cooking function.

1. After selecting the Pyrolytic function and the duration of the cycle (excluding the Eco Pyrolytic), press the programming knob. The display shows the current time, and the temperature and the  indicator light comes on.
2. Turn the programming knob to set the time you wish the Pyrolytic cycle to finish.
3. Press the programming knob to confirm the parameters entered. The , , and  indicator lights remain lit steadily and the appliance waits for the set start time to start the Pyrolytic cycle.

It is not possible to select any function once the door lock device has been activated. It remains possible, however, to switch off the appliance using the specific controls.

## Extraordinary maintenance

### Replacing the internal light bulb

#### Live parts

#### Danger of electrocution

- Unplug the appliance from the power supply.
1. Completely remove all accessories from inside the oven.
  2. Remove the rack/tray support frames.

3. Remove the bulb cover using a tool (e.g.a screwdriver).

- Be careful not to scratch the enamel on the side of the oven.

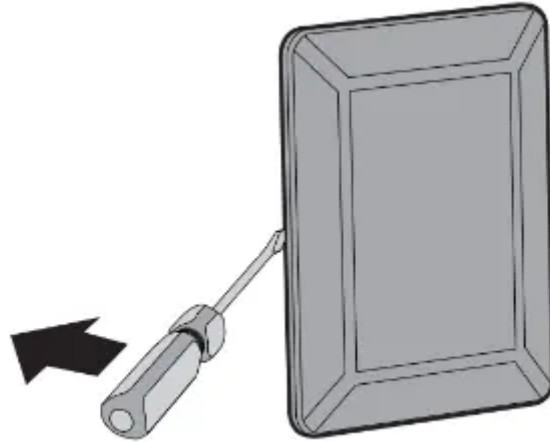

4.

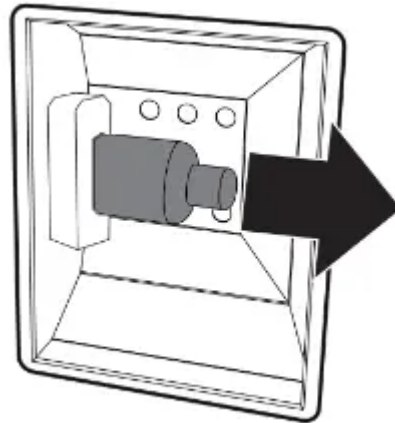

Slide the lamp out and remove it.

- Do not touch the halogen lamp directly with your fingers, but hold it using an insulating material.

5. Replace the lamp with one of the same type (40W).

6. Replace the bulb cover. Make sure that the inner shaped part of the glass (A) is facing

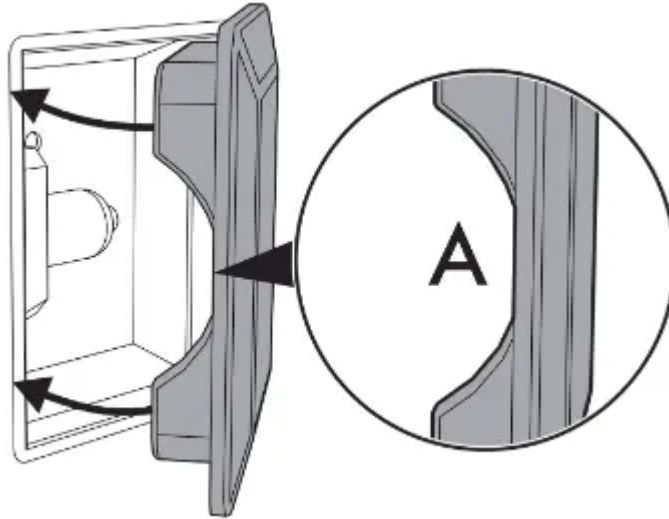

the door.

7. Press the cover completely down so that it attaches perfectly to the bulb support.

## Installation

### Electrical connection

#### Power voltage. Danger of electrocution

- Have the electrical connection performed by authorized persons.
- The appliance must be connected to the earth in compliance with electrical system safety standards.
- Disconnect the mains power supply.

### General information

Check the grid characteristics against the data indicated on the plate.

The identification plate bearing the technical data, serial number, and brand name is visibly positioned on the appliance.

Do not remove this plate for any reason. The appliance works at 220-240 V~.

Use a three-pole cable (3 x 1.5 mm<sup>2</sup> internal conductors).

Make the ground connection using a wire that is 20 mm longer than the other wires.

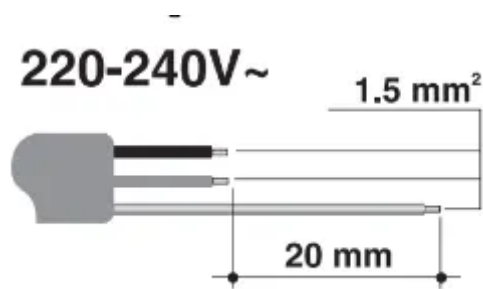

### Fixed connection

Fit the power line with an omnipolar circuit breaker in compliance with installation regulations. The circuit breaker should be located near the appliance and in an easily reachable position.

### Connection with plug and socket

Make sure that the plug and socket are of the same type.

Avoid using adapters, gang sockets, or extensions as these could cause overheating and a risk of burns.

### Cable replacement

#### Power voltage. Danger of electrocution

- Disconnect the mains power supply.
1. Unscrew the rear casing screws and remove the casing in order to access the terminal

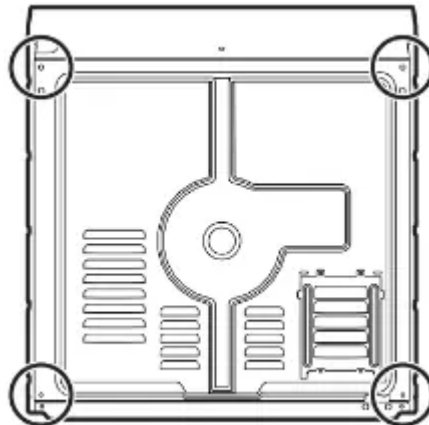

board.

2. Replace the cable.
3. Make sure that the cables (for the oven or any cooktop) follow the best route in order to avoid any contact with the appliance.

### Positioning

#### Heavy appliance. Crushing hazard

- Position the appliance into the cabinet cutout with the help of a second person.

### **Pressure on the open door. Risk of damage to the appliance**

- Never use the oven door to lever the appliance into place when fitting.
- Avoid exerting too much pressure on the oven door when open.

### **Heat production during appliance operation. Risk of fire**

- Check that the piece of furniture material is heat resistant.
- Check that the piece of furniture has the required slots.
- Do not install the appliance in a recess that can be closed with a door or in a cupboard.

### **Position of the power cable**

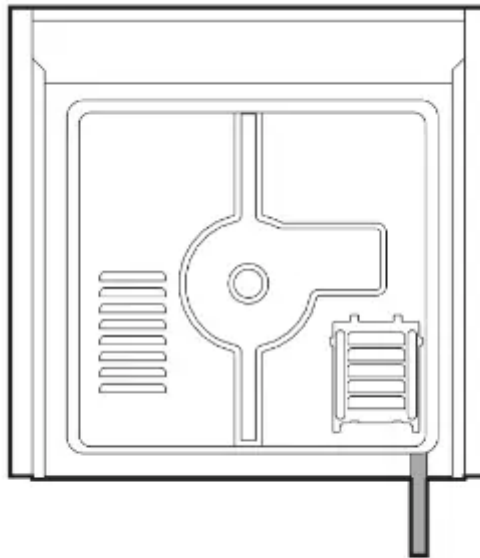

**(rear view)**

### **Front panel seal**

Glue the seal provided to the rear of the front panel to prevent water or other liquids from leaking in.

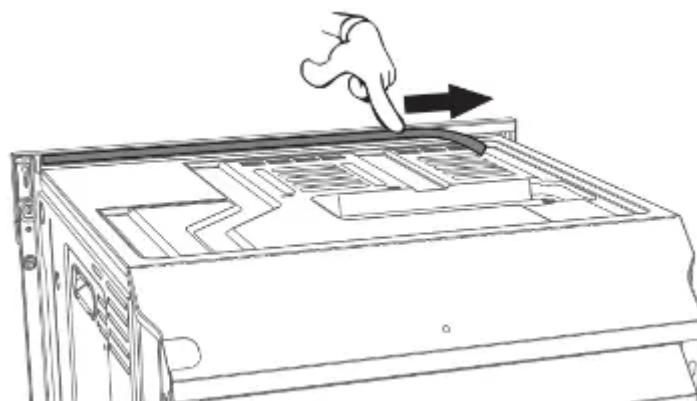

## Fastening bushings

1. Remove the bushing covers inserted on the front of the appliance.

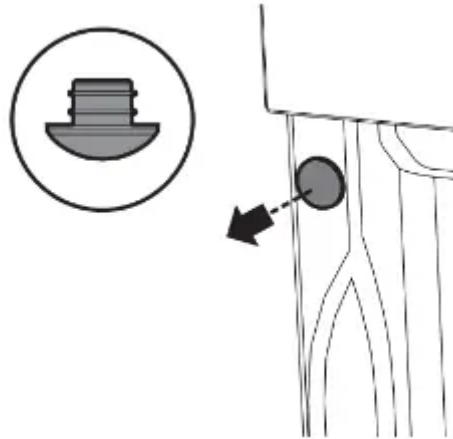

2. Mount the appliance into the recess.

3. Secure the appliance to the piece of furniture using the screws.

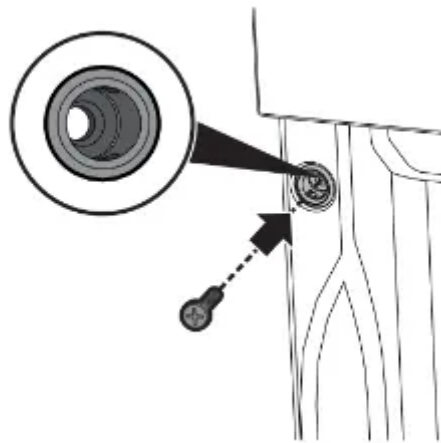

4. Cover the bushings using the covers that were previously removed.

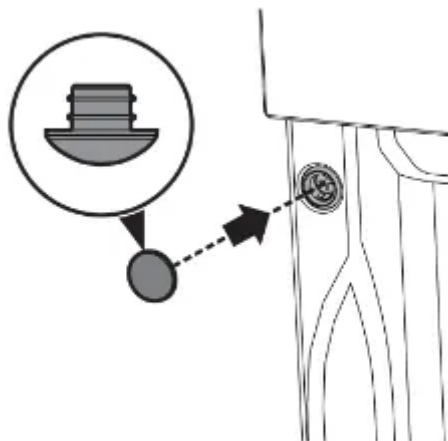

## Appliance overall dimensions (mm)

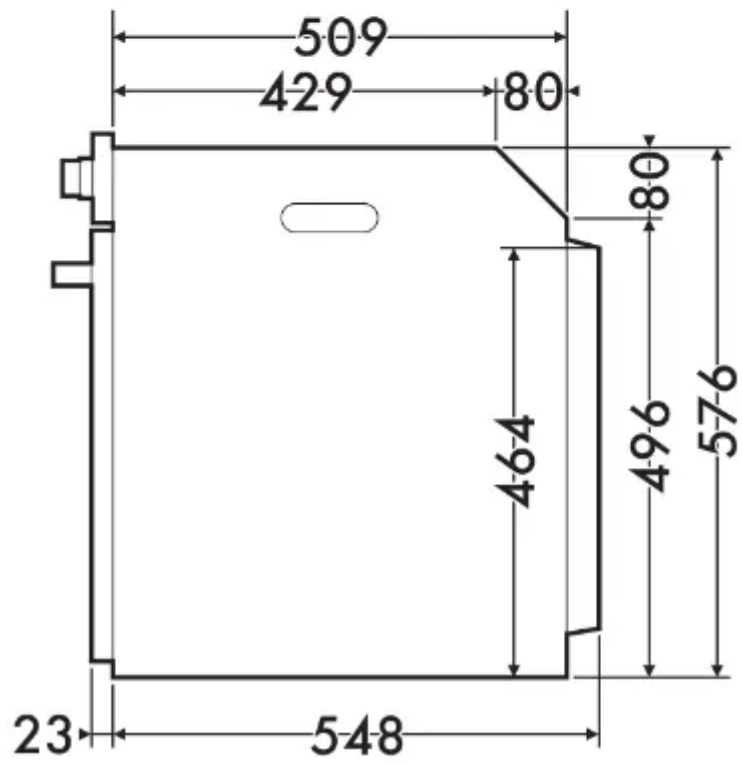
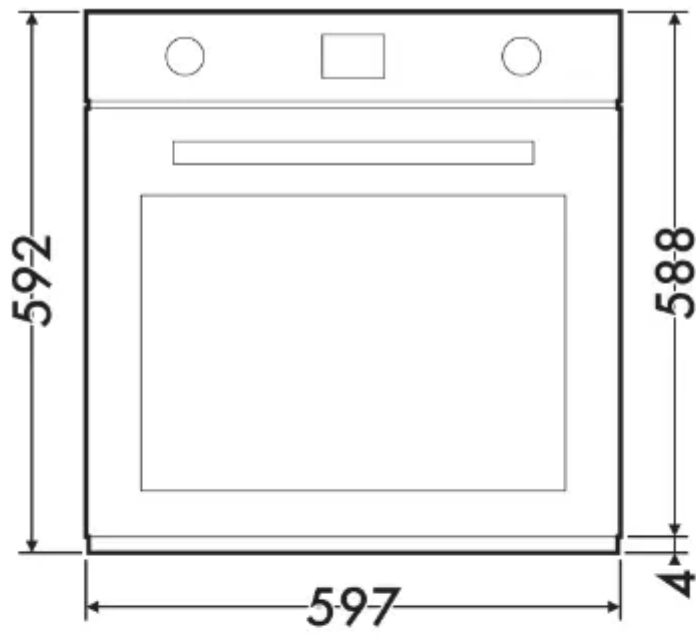



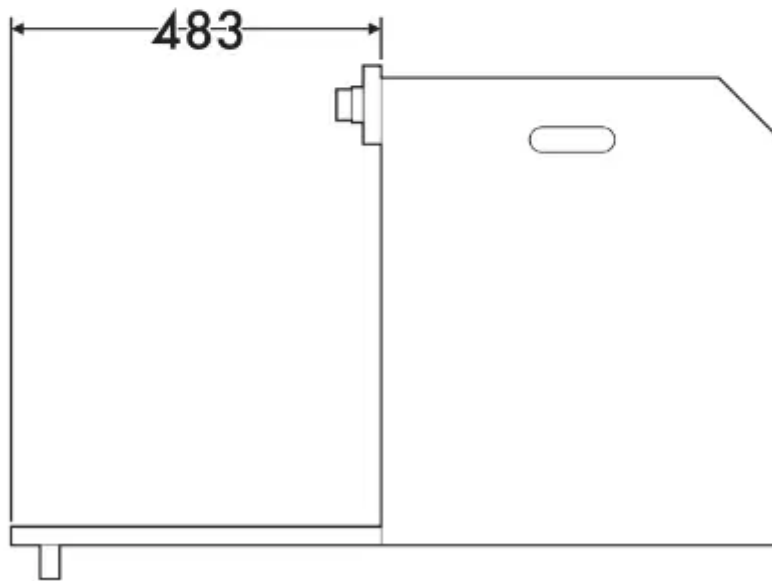
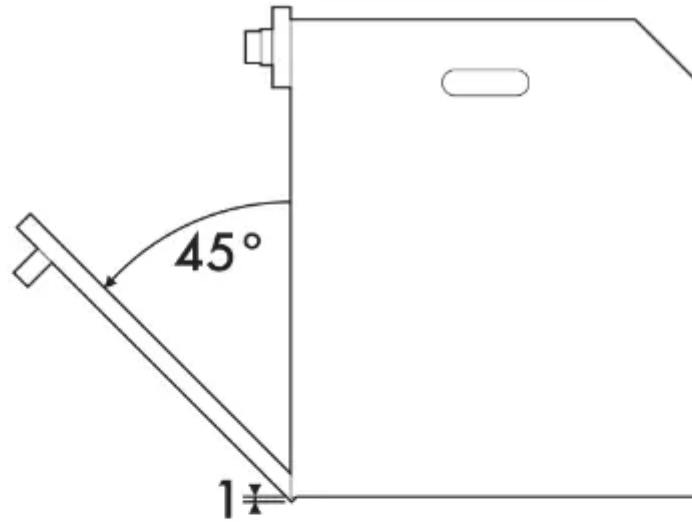

**Mounting under worktops (mm)**



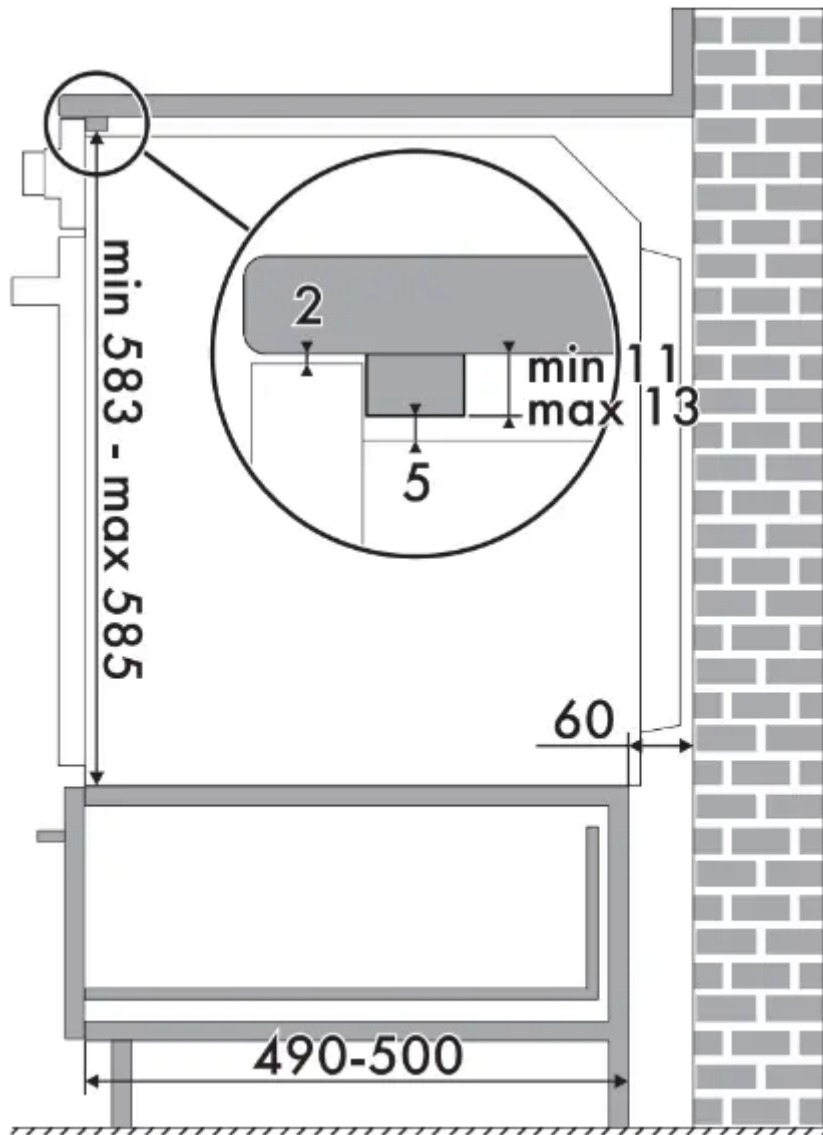
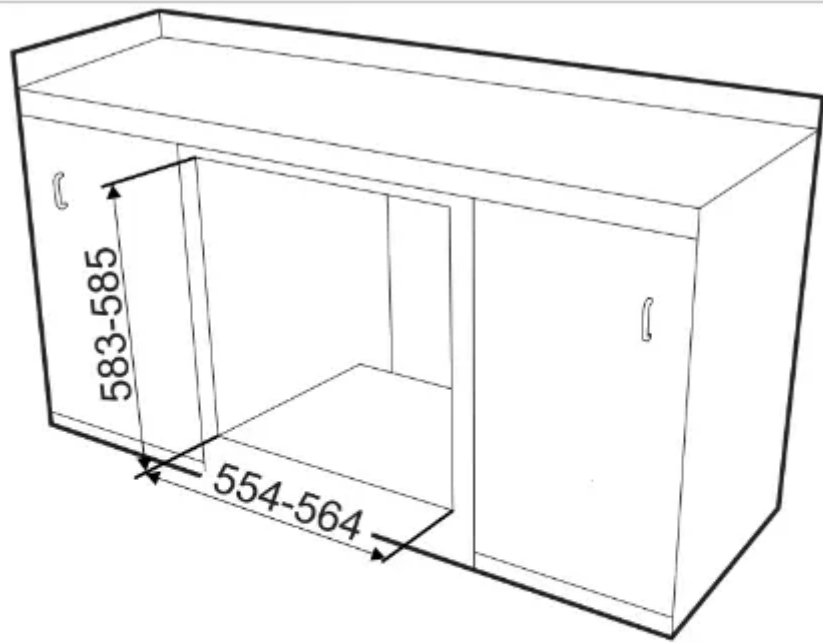

Make sure that the piece of furniture's rear/bottom part has an opening of approx. 60 mm.



### Mounting into a column (mm)

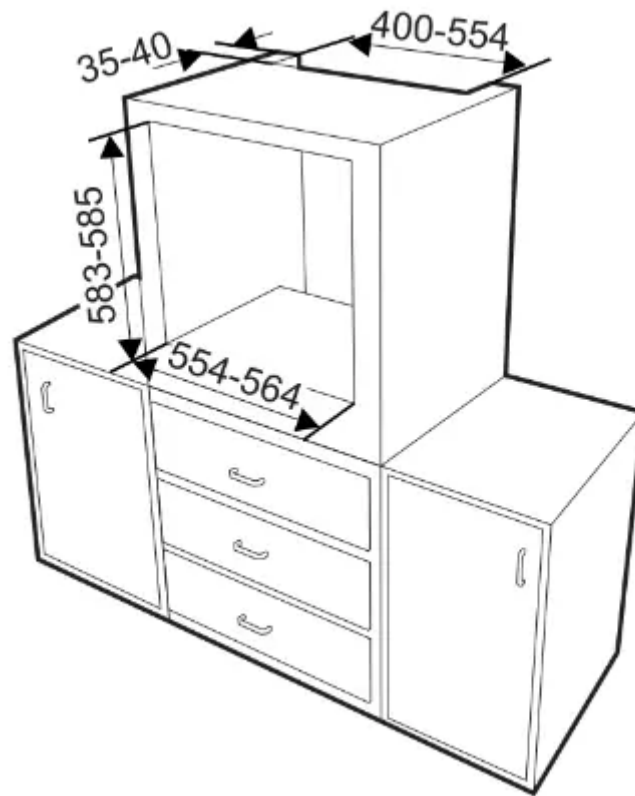

Make sure that the piece of furniture's top/rear part has an opening of approx. 35-40 mm deep.

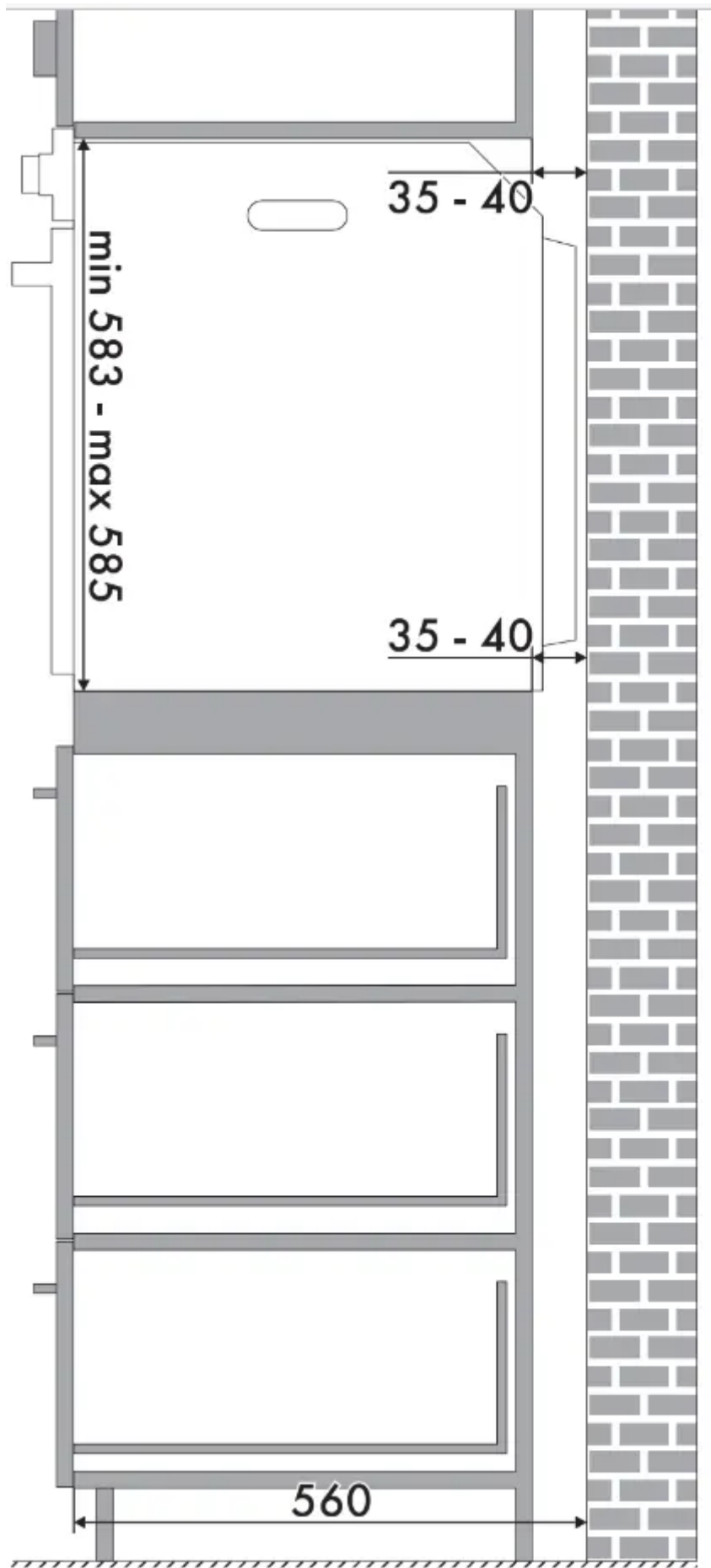

**Warning**

This content is compiled from multiple sources and is provided for reference purposes only. It may not be complete or fully applicable to all situations. If you are unable to resolve your issue, please contact the product manufacturer or an authorized service provider for official support.

---

Document generated by [ManualsFile](#)