

## Assembly

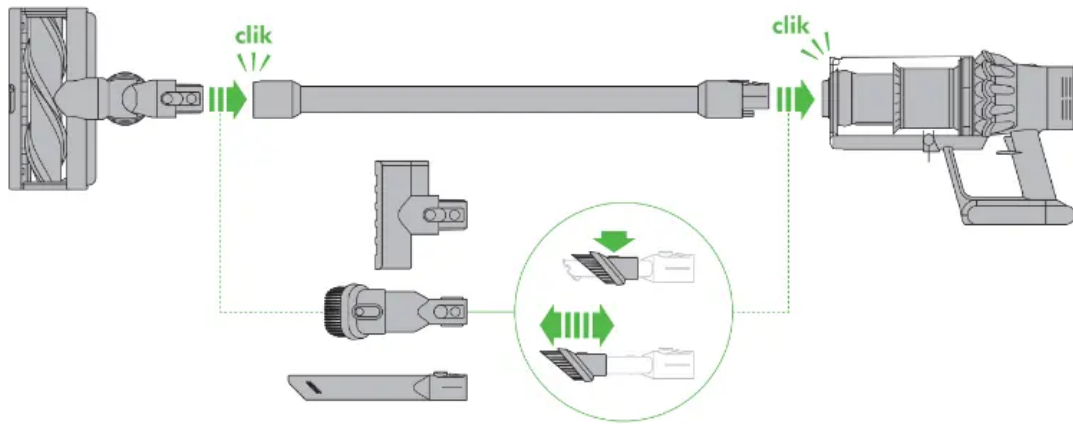

### Wash the filter unit

Wash the filter unit with cold water at least every month. Ensure that the filter unit is completely dry before refitting.



### Register today

3 easy ways to register your year limited warranty.

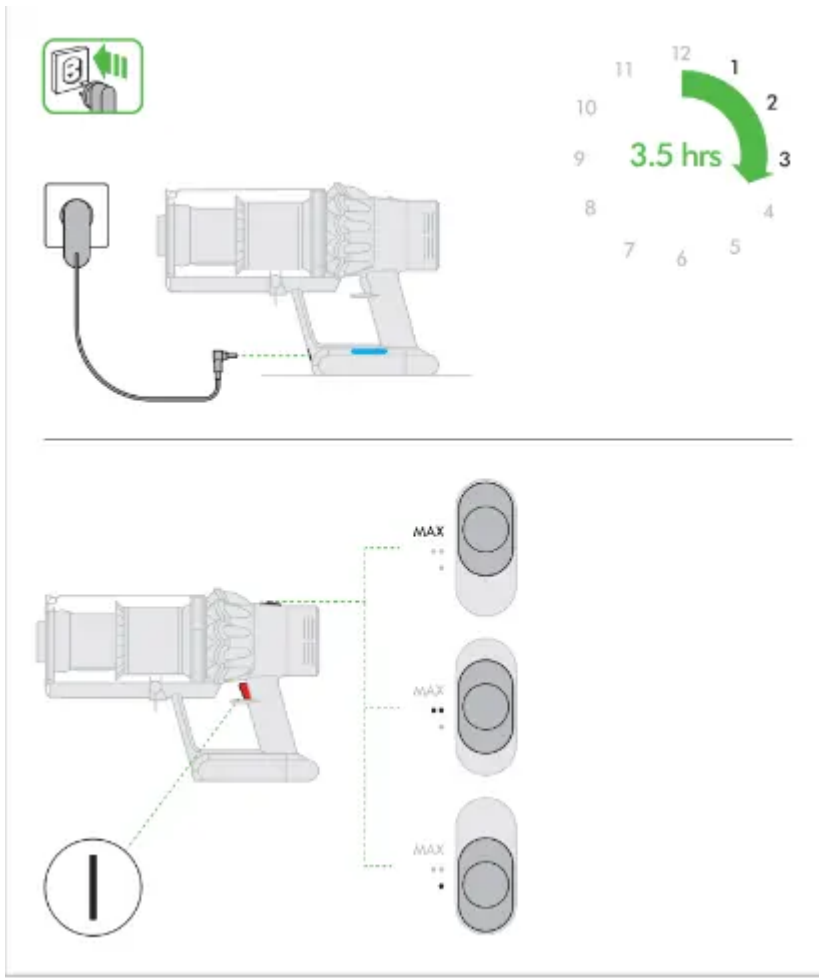

Power mode



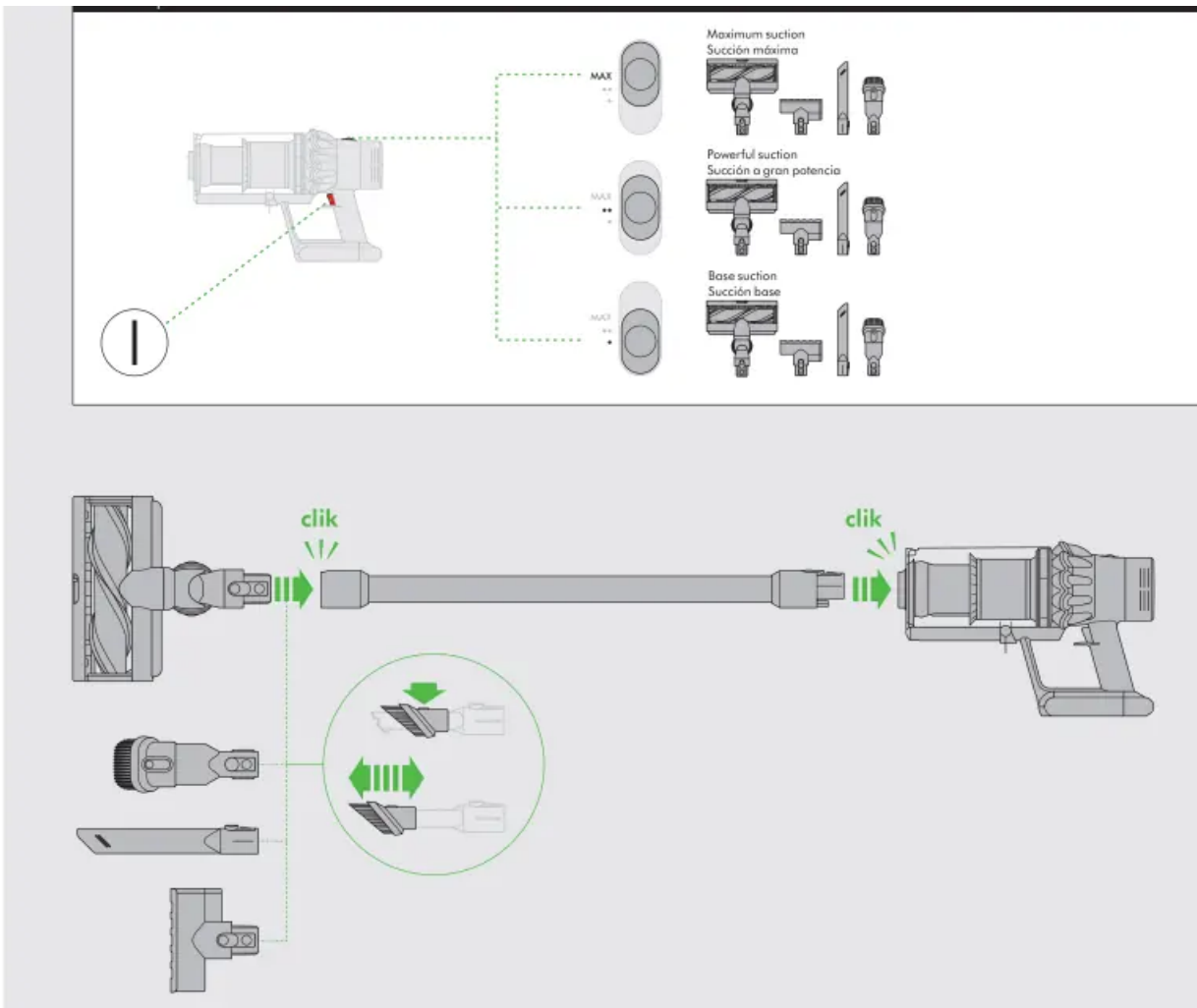

## Recharging

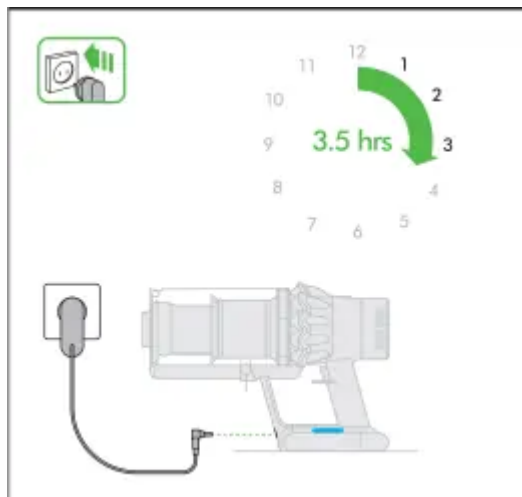

## Recharging on the dock

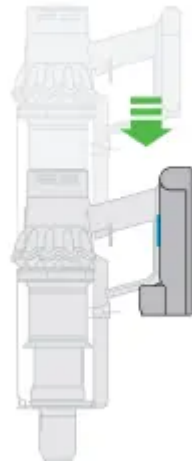

### Lights during charging



For further diagnostics refer to the 'Usage' section.  
Para obtener más información de diagnóstico, consulte la sección sobre uso.

### Lights during use



For further diagnostics refer to the 'Usage' section.  
Para obtener más información de diagnóstico, consulte la sección sobre uso.

### Filter and blockage indicator LEDs

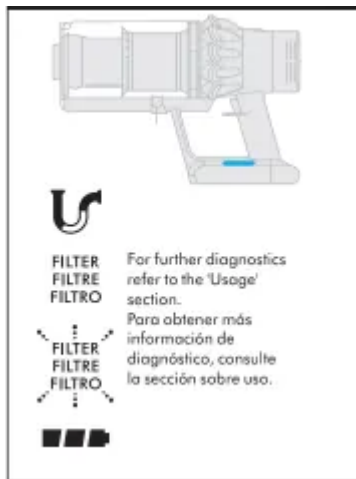

**Torque drive cleaner head modes**

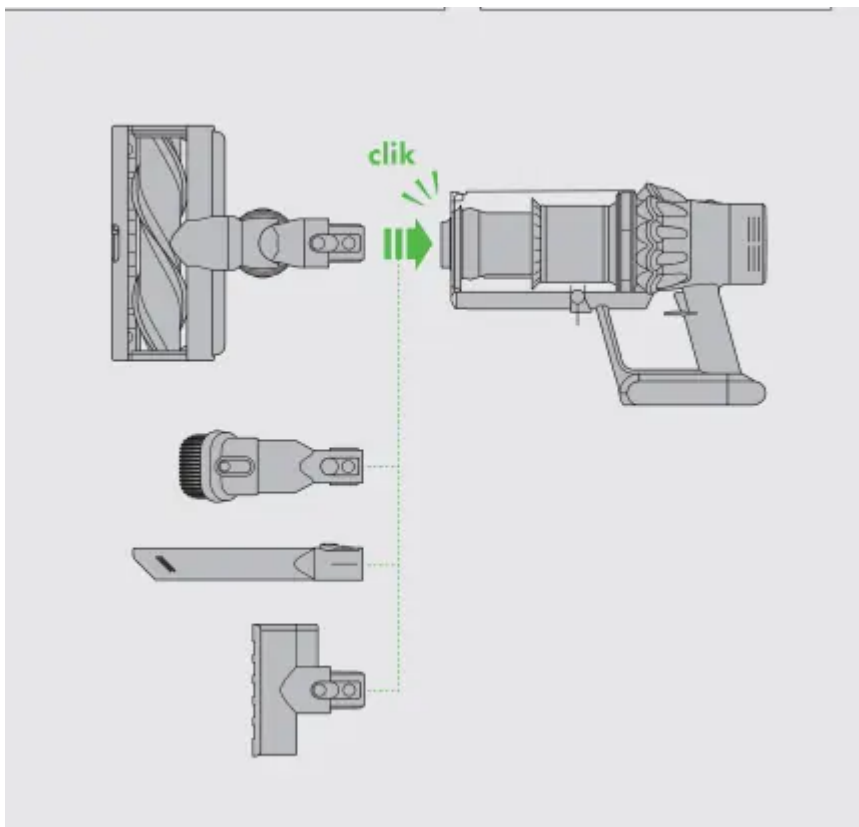
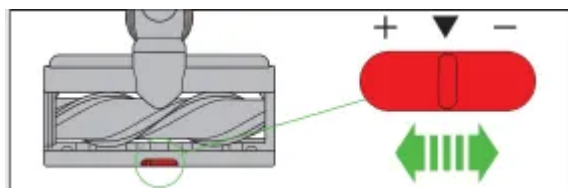

**Emptying the clear bin**



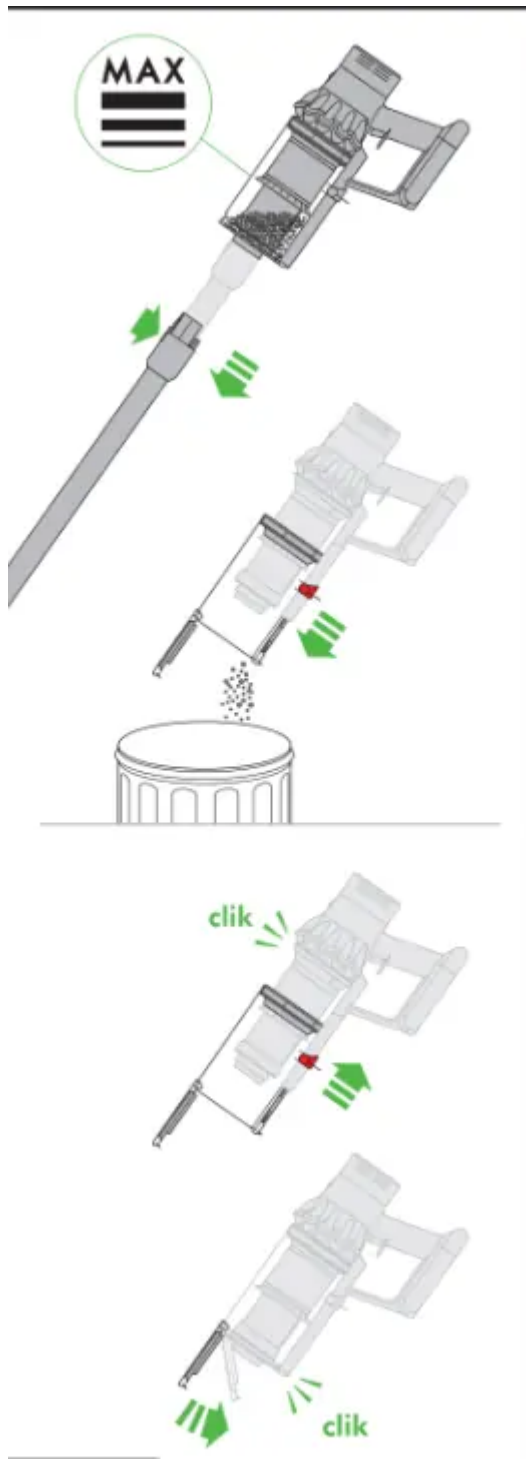

Lights diagnostics



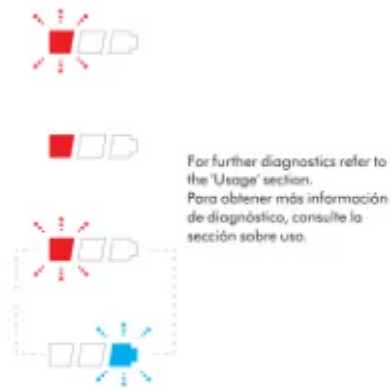

## USEN

### USING YOUR DYSON MACHINE

PLEASE READ THE "IMPORTANT SAFETY INSTRUCTIONS" IN THIS DYSON OPERATING MANUAL BEFORE PROCEEDING.

### DOCKING STATION INSTALLATION

- Unpack the docking station, plug and installation leaflet.
- Select the location for the docking station and ensure that there is no pipework gas, water or air), electrical cables, wires or ductwork directly behind the mounting location.
- Follow the instructions on the Installation leaflet.
- Click the attachments into place.
- Place the machine in the docking station.
- Plug in the docking station and turn on to charge.
- Your machine will need to be fully charged before first use.

Dyson recommends the use of protective clothing, eyewear and materials when installing the docking station.

### VACUUMING

- Remove the machine from the docking station.
- Check that the underside of the cleaner head or tool is clean and free from foreign objects that may cause damage.
- Your machine has a slider control on the cleaner head to adjust the suction. Select the suction required:

## MAXIMUM SUCTION FOR GROUND IN DUST AND DEBRIS (+)

- For vacuuming durable floor coverings, hard floors and heavily soiled carpets and rugs.
- Before vacuuming your flooring, rugs and carpets, check the manufacturer's recommended cleaning instructions.
- Your machine is pre-set to this level of suction when you take it out of the box.

## SUCTION FOR DUST AND DEBRIS

- For vacuuming of lightly soiled carpets, rugs and hard flooring.
- For vacuuming of large debris such as peanuts or rice.
  - To switch to this setting, move the suction control slider on top of the cleaner head.

## SUCTION FOR DEEP PILE CARPETS AND DELICATE FLOORING (-)

- For vacuuming deep pile carpets or rugs and any flooring on which you may experience greater resistance.
- For vacuuming of lightly soiled floors, including delicate flooring such as vinyl, parquet and lino.

- To switch to this setting, move the suction control slider on top of the cleaner head. Before vacuuming your flooring, rugs and carpets, check the manufacturer's recommended cleaning instructions.

The brush bar on the machine can damage certain carpet types and floors. Some carpets will fuzz if a rotating brush bar is used when vacuuming. If this happens, we recommend vacuuming without the motorized floor tool and consulting with your flooring manufacturer.

## LIGHTS DURING CHARGING



Charging, low charge



Charging, nearly full



Charging, medium charge



Fully charged

## LIGHTS DURING USE



High level of charge



Medium level of charge

 Low level of charge

 Empty, needs charging

## LIGHTS DIAGNOSTICS

 Battery fault - call Dyson Helpline

 Main body fault - call Dyson Helpline

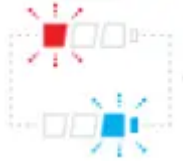
 Charger fault - call Dyson Helpline

## FILTER AND BLOCKAGE INDICATOR LEDS

 Blockage indicator

 FILTER  
FILTRE  
FILTRO Filter unit requires washing

 FILTER  
FILTRE  
FILTRO Filter unit not fitted correctly

 See battery section

## EMPTYING THE CLEAR BIN

- Empty as soon as the dirt reaches the level of the MAX mark – do not overfill.
- Ensure the machine is disconnected from the charger before emptying the clear bin.
- Be careful not to pull the “ON” trigger.
- Avoid pulling the "ON" trigger when emptying.
- Remove the wand by pressing the red wand release button and pulling away from the bin.
- To release the dirt:
  - Hold the machine with the bin in a downwards position.
  - Firmly push the red bin release button.
  - The bin will slide down, cleaning the shroud as it goes.
  - The bin base will then open.
  - The bin base will not open if the red button is not pushed down fully.

To minimize dust/allergen contact when emptying, encase the clear bin tightly in a plastic bag and empty.

Remove the clear bin carefully from the bag.  
Seal the bag tightly, dispose as normal.

## **CLEANING THE CLEAR BIN (OPTIONAL)**

If it is necessary to clean the clear bin:

- Follow the instructions in the "Emptying the clear bin" section.
- Press the red button located on the bin runner to release the bin and slide the bin off the runner.
- Clean the clear bin with a damp cloth only.
- Ensure that the clear bin and seals are completely dry before replacing.
- To refit the clear bin:

- Insert the spine on to the bin runner.

Close the clear bin by pushing the bin base upwards until the clear bin and bin base click into place.

The clear bin is not dishwasher safe and the use of detergents, polishes or air fresheners to clean the clear bin is not recommended as this may damage your machine.

## **FILTER AND BLOCKAGE INDICATOR LEDS**

Your machine has two indicator lights that will help alert you that simple maintenance steps are needed.

- The filter indicator will flash intermittently when the filter unit is not fitted correctly.
- Follow the instructions on how to refit the filter unit in the 'Washing the filter unit' section.
- The filter indicator will light continuously when the filter unit needs washing. Follow the instructions on how to wash the filter unit in the 'Washing the filter unit' section.
- The blockage Indicator LED will light if there is a blockage. Follow the instructions on how to clear blockages in the 'Looking for blockages' section.

## **WASHABLE PARTS**

Your machine has washable parts, which require regular cleaning. Follow the instructions below.

## **WASHING THE FILTER UNIT**

Check and wash the filter unit, according to the instructions, to maintain performance.

- Remove the filter unit by twisting counterclockwise to the open position. Gently pull away from the machine.

- Wash the inside of the filter unit first; hold it upright under the cold water tap and agitate using a rotating motion.
- Wash the outside of the filter unit; fill the unit with cold water, place your hand over the open end and shake gently.
- Repeat washing the inside and outside of the filter unit until the water runs clear.
- Gently tap the filter unit to remove any excess water and leave to dry with the filter end down.
- Leave the filter unit to dry completely for a minimum of 24 hours.
- Check that the filter unit is completely dry.

To refit, return the filter unit to the open position and twist clockwise until it clicks into place.

The filter unit may require more frequent washing if vacuuming fine dust or using mainly maximum suction.

Do not put the filter unit in a dishwasher, washing machine, tumble dryer, oven, microwave or near a naked flame.

## **BLOCKAGES – AUTOMATIC CUT-OUT**

- This machine is fitted with an automatic cut-out.
- If any part becomes blocked the machine may automatically cut out. This will happen after the motor pulses a number of times (i.e switches on and off in quick succession) and the blockage indicator LED will illuminate.
- Leave to cool down before looking for blockages.
- Ensure the machine is disconnected from the charger before looking for blockages. Failure to do so could result in personal injury.
- Clear any blockage before restarting.
- Refit all parts securely before using.
- Clearing blockages is not covered by your warranty.

## **LOOKING FOR BLOCKAGES**

The motor will pulse and the blockage indicator LED will illuminate when there is a blockage. Please follow the instructions below to locate the blockage:

- Ensure the machine is disconnected from the charger before looking for blockages.
- Be careful not to pull the “ON” trigger.
- Do not operate while checking for blockages as doing so could result in personal injury.
- Beware of sharp objects when checking for blockages.

- To check for blockages in the main body of the machine, remove the clear bin following the instructions in the cleaning the clear bin section and remove the blockage.
- If you cannot clear an obstruction from the cleaner head, you may need to remove the brush bar. Use a coin to unlock the fastener, slide the brush bar out of the cleaner head and remove the obstruction. Replace the brush bar and secure it by tightening the fastener. Ensure it is fixed firmly before operating the machine.
- This machine has carbon fiber brushes. Take care if coming into contact with them, as they may cause minor skin irritation. Wash your hands after handling the brushes.
- Refit all parts securely before using.
- Clearing blockages is not covered by your warranty.

## CHARGING AND STORAGE

- This machine will switch “OFF” if the battery temperature is below 37.4°F (3°C). This is designed to protect the motor and battery. Do not charge the machine and then move it to an area with a temperature below 37.4°F (3°C) for storage purposes.
- To help prolong battery life, avoid recharging immediately after a full discharge.
- Allow to cool for a few minutes.
- Avoid using the machine with the battery flush to a surface. This will help it run cooler and prolong battery run time and life.

## BATTERY SAFETY INSTRUCTIONS

- If the battery needs replacing please contact the Dyson Helpline.
- Use only Dyson chargers for charging this Dyson machine.
- The battery is a sealed unit and under normal circumstances poses no safety concerns. Liquid ejected from the battery may cause irritation or burns. In the unlikely event that liquid leaks from the battery do not touch the liquid and observe the following precautions:
  - Skin contact – can cause irritation. Wash with soap and water.
  - Inhalation – can cause respiratory irritation. Expose to fresh air and seek medical advice.
  - Eye contact – can cause irritation. Immediately flush eyes thoroughly with water for at least 15 minutes. Seek medical attention.
  - Disposal – wear gloves to handle the battery and dispose of immediately, following local ordinances or regulations.

 **CAUTION**

The battery used in this device may present a risk of fire or chemical burn if mistreated. Do not disassemble, short contacts, heat above 140°F (60°C), or incinerate. Keep away from children. Do not disassemble and do not dispose of in fire.

## **DISPOSAL INFORMATION**

- Dyson products are made from high grade recyclable materials. Recycle where possible.
- The battery should be removed from the product before disposal.
- Dispose of or recycle the battery in accordance with local ordinances or regulations.
- Dispose of the exhausted filter unit in accordance with local ordinances or regulations.

## **DYSON CUSTOMER CARE**

THANK YOU FOR CHOOSING TO BUY A DYSON MACHINE.

After registering your 2 year warranty, your Dyson machine will be covered for parts and labor (excluding filters) for 2 years from the date of purchase, subject to the terms of the warranty. If you have any questions regarding your Dyson machine, visit [www.dyson.com](http://www.dyson.com) for online help, general tips and useful information about Dyson.

Alternatively, you can call the Dyson Helpline with your serial number and details of where/when you bought the machine.

If your Dyson machine needs a repair, call the Dyson Helpline so we can discuss the available options. If your Dyson machine is under warranty, and it is a covered repair, it will be repaired at no cost.

## **PLEASE REGISTER AS A DYSON MACHINE OWNER**

To help us ensure you receive prompt and efficient service, please register as a Dyson machine owner. There are three ways to do this:

- Online at [www.dyson.com](http://www.dyson.com)
- Telephone the Dyson Helpline on 1-855-533-1098.
- Complete the enclosed Warranty Form and mail it to us.

This will confirm ownership of your Dyson machine in the event of an insurance loss, and enable us to contact you if necessary.

## **2 YEAR LIMITED WARRANTY**

TERMS AND CONDITIONS OF THE DYSON 2 YEAR LIMITED WARRANTY

## **WHAT IS COVERED**

Your Dyson machine is warranted against original defects in materials and workmanship for a period of 2 years from the date of purchase, when used for normal domestic purposes in accordance with the Dyson Operating Manual.

Please retain your proof of purchase. If you do not have your proof of purchase, your warranty will start 90 days after the date of manufacture, according to

Dyson's records. This warranty provides, at no extra cost to you, all labor and parts necessary to ensure your machine is in proper operating condition during the warranty period. The replacement of any part of your machine under warranty will not extend the period of warranty. Any parts which are returned to Dyson will become the property of Dyson. Please call the Dyson Helpline at 1-855-533-1098 for more information. For refurbished machines, length of warranty may differ, please see warranty letter included with machine for warranty terms. This limited warranty is subject to the following terms:

## **WHAT IS NOT COVERED**

Dyson shall not be liable for costs, damages or repairs incurred as a result of, due to, or from:

- Purchases of machines from unauthorized dealers.
- Careless operation or handling, misuse, abuse and/or lack of maintenance or use not in accordance with the Dyson Operating Manual.
- Use of the machine other than for normal domestic purposes within the United States, e.g. for commercial or rental purposes.
- Use of parts not in accordance with the Dyson Operating Manual.
- Use of parts and accessories other than those produced or recommended by Dyson.
- External sources such as weather, electrical outages or power surges.
- Repairs or alterations carried out by unauthorized parties or agents.
- Clearing blockages from your machine or washing of the filter.
- Normal wear and tear, including normal wearing parts, such as clear bin, filter, brush bar, and power cord (or where external damage or abuse is diagnosed), carpet or floor damage due to use not in accordance with the Dyson Operating Manual or failure to turn the brush bar off when necessary.
- Reduction in battery discharge time due to battery age or use (where applicable).
- Damage as a result of use not in accordance with the rating plate.
- Use of this machine on rubble, ash, plaster, drywall, liquids, or wet surfaces.
- Additionally, this limited warranty does not apply to any machine that has had the serial number altered or removed.

## WARRANTY LIMITATIONS AND EXCLUSIONS

- Any implied warranties relating to your machine including but not limited to warranty of merchantability or warranty of fitness for a particular purpose, are limited to the duration of this warranty. This limitation is not allowed by some States, and so this limitation may not apply to you.
- Your remedy for breach of this warranty is limited to the warranty service described below. Dyson will not be liable for any consequential damages or incidental damages you may incur in connection with your purchase and use of your machine.
- This limitation is not allowed by some States and so this limitation may not apply to you.
- This limited warranty gives you specific legal rights. You may also have other rights which vary by State.
- This limited warranty is not transferable.

## WARRANTY SERVICE

- Please fill out and return the Warranty Form, or register online at [www.dyson.com](http://www.dyson.com)
- Before service can take place, the terms of the warranty require that you contact the Dyson Helpline with your model name/number, serial number, date and place of purchase.
- Please keep your purchase receipt in a safe place to ensure you have this information.
- All work will be coordinated by Dyson or its authorized agents.
- Any replaced defective parts will become the property of Dyson.
- Service under this warranty will not extend the period of this warranty. If your machine is not functioning properly, please call the Dyson Helpline at Most issues can be rectified over the telephone by our trained Customer Care staff.

## WHEN REGISTERING YOUR DYSON MACHINE

- You will need to provide us with basic contact information to register your product and enable us to support your warranty.
- When you register, you will have the opportunity to choose whether you would like to receive communications from us. If you opt-in to communications from Dyson, we will send you details of special offers and news of our latest innovations. We never sell your information to third parties and only use information that you share with us as defined by our privacy policies which are available on our website at [privacy.dyson.com](http://privacy.dyson.com).

## CONFORMITY INFORMATION

This device complies with part 15 of the FCC Rules. Operation is subject to the following two conditions: (1) This device may not cause harmful interference, and this device must accept any interference received, including interference that may cause undesired operation.

This equipment has been tested and found to comply with the limits for a Class B digital device, pursuant to part 15 of the FCC Rules. These limits are designed to provide reasonable protection against harmful interference in a residential installation. This equipment generates, uses and can radiate radio frequency energy and, if not installed and used in accordance with the instructions, may cause harmful interference to radio communications. However, there is no guarantee that interference will not occur in a particular installation. If this equipment does cause harmful interference to radio or television reception, which can be determined by turning the equipment off and on, the user is encouraged to try to correct the interference by one or more of the following measures:

- Reorient or relocate the receiving antenna.
- Increase the separation between the equipment and receiver.
- Connect the equipment into an outlet on a circuit different from that to which the receiver is connected.
- Consult the dealer or an experienced radio/TV technician for help.

Changes or modifications not expressly approved by the party responsible for compliance could void the user's authority to operate the equipment.

## PRODUCT INFORMATION

Please note: Small details may vary from those shown.

### Warning

This content is compiled from multiple sources and is provided for reference purposes only. It may not be complete or fully applicable to all situations. If you are unable to resolve your issue, please contact the product manufacturer or an authorized service provider for official support.