

## REFRIGERATOR USE

### Using the Controls

Your refrigerator has two controls that affect the temperature. The Temperature control is located at the top front of the refrigerator compartment and the Airflow control is located on the back wall of the freezer compartment.

#### IMPORTANT:

- The recommended setting should be correct for normal household refrigerator use. The controls are set correctly when milk or juice is as cold as you like and when ice cream is firm.
- Wait 24 hours for your refrigerator to cool completely before adding food. If you add food before the refrigerator has cooled completely, your food may spoil.

NOTE: Adjusting the refrigerator and freezer temperature controls to a colder than recommended setting will not cool the compartments any faster.

- If the temperature is too warm or too cold in the refrigerator or freezer, first check the air vents to be sure they are not blocked before adjusting the controls.

### Temperature Control

For your convenience, the temperature control is preset at the factory. When you first install your refrigerator, make sure the control is still preset as shown.

#### Recommended Setting

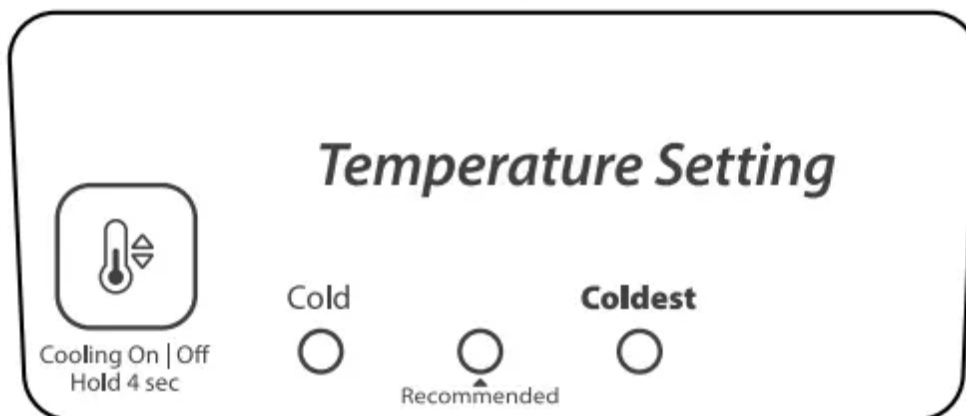

### Cooling Off/On

- To turn Cooling Off, press and hold the Temperature Setting button for 4 seconds, until all lights turn ON for 1 second. To turn cooling back on, press and hold the Temperature Setting button again for 4 seconds.

NOTE: Neither compartment will cool when the control is set to OFF.



### **Adjusting the Temperature Control**

If you need to adjust the temperature in either the refrigerator or freezer compartment, use the settings listed in the chart below as a guide.

**NOTE:** Except when starting the refrigerator, do not adjust the control more than one setting at a time. Wait 24 hours between adjustments for the temperature to stabilize.

- Press the Temperature Setting button to toggle among the three LED lights which indicate the temperature setting. Reading from left to right, the LED in the first position is the least cold. The LEDs indicate increasingly colder settings as you continue to the right.

<b>CONDITION/REASON:</b>	<b>ADJUSTMENT:</b>
REFRIGERATOR too warm	TEMPERATURE Control one setting higher
FREEZER too warm/too little ice	AIRFLOW or TEMPERATURE Control one setting higher
REFRIGERATOR too cold	TEMPERATURE Control one setting lower
FREEZER too cold	AIRFLOW or TEMPERATURE Control one setting lower

### **Airflow Control**

The Airflow control regulates the amount of air flowing between the freezer and the refrigerator compartments.

When you plug in the refrigerator for the first time, turn the Airflow control to the Recommended setting.

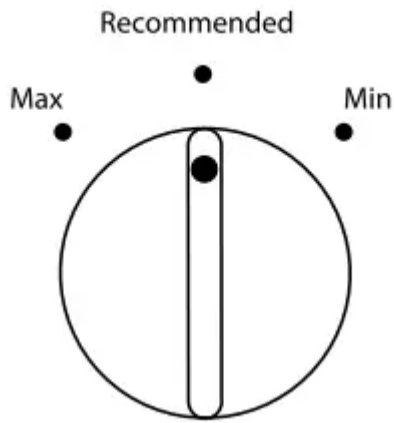

### ***Adjusting the Airflow Control***

If you want to temporarily increase the cold airflow to a specific compartment, adjust the control.

- Max - Increase airflow to the freezer
- Min - Increase airflow to the refrigerator

**IMPORTANT:** Once the performance is achieved, return the Airflow control to the Recommended setting to keep the refrigerator operating at optimum efficiency.

<b>CONDITION/REASON:</b>	<b>ADJUSTMENT:</b>
Heavy ice use	Max
Hot room temperature	Max - To maintain ice making production rate
Large quantity of groceries	Min - To quickly chill food and beverages

### **Ice Maker (on some models)**

#### **Turning the Ice Maker On/Off**

**NOTE:** Do not force the wire shutoff arm up or down.

- To turn the ice maker on, simply lower the wire shutoff arm.

**NOTE:** Your ice maker has an automatic shutoff. As ice is made, the ice cubes will fill the ice storage bin and the ice cubes will raise the wire shutoff arm to the OFF (arm up) position.

- To manually turn the ice maker off, lift the wire shutoff arm to the OFF (arm up) position and listen for the click to make sure the ice maker will not continue to operate.

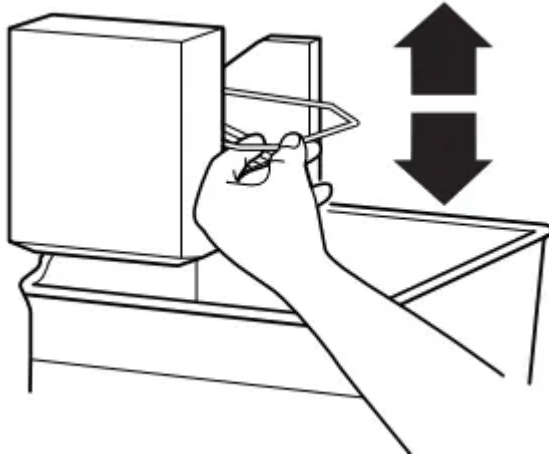

NOTE: Turn the ice maker off before removing the ice storage bin to serve ice or to clean the bin. This will keep the ice cubes from dropping out of the ice maker and into the freezer compartment. After replacing the ice storage bin, turn on the ice maker.

### Ice Production Rate

- **NORMAL Ice Production:** The ice maker should produce approximately 8 to 12 batches of ice in a 24-hour period. If ice is not being made fast enough, turn the Freezer control toward a higher (colder) number in half number steps. (For example, if the control is at 3, move it to between 3 and 4.) Wait 24 hours and, if necessary, gradually turn the Freezer control to the highest setting, waiting 24 hours between each increase.
- **MAXIMUM Ice Production (on some models):** The ice maker should produce approximately 16 to 20 batches of ice in a 24-hour period. If your refrigerator has the maximum ice production feature, push the switch to MAX.

### Remember

- Allow 24 hours to produce the first batch of ice. Allow 3 days to completely fill the ice storage bin. Discard the first three batches of ice produced.
- The quality of your ice will be only as good as the quality of the water supplied to your ice maker. Avoid connecting the ice maker to a softened water supply. Water softener chemicals (such as salt) can damage parts of the ice maker and lead to poor quality ice. If a softened water supply cannot be avoided, make sure the water softener is operating properly and is well maintained.
- Do not store anything on top of the ice maker or in the ice storage bin.

## REFRIGERATOR FEATURES

### Refrigerator Shelves

The shelves in your refrigerator are adjustable to match your individual storage needs.

Storing similar food items together in your refrigerator and adjusting the shelves to fit different heights of items will make finding the exact item you want easier. It will also reduce the amount of time the refrigerator door is open, and save energy.

**To remove and replace a shelf:**

1. Remove items from the shelf.
2. Slide the shelf straight out to the stop.
3. Depending on your model, lift back or front of the shelf past the stop. Slide shelf out the rest of the way
4. Replace the shelf by sliding the back of the shelf into the track in the wall of the cabinet.
5. Guide the front of the shelf into the shelf track. Be sure to slide the shelf in all the way

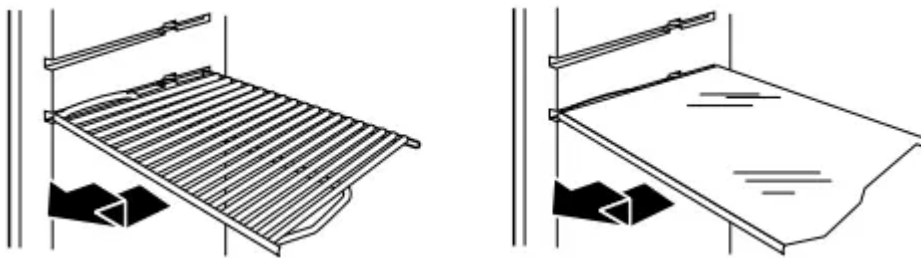

**Crisper**

**Crisper Drawers**

***To remove and replace the crisper drawer:***

1. Slide the crisper drawer straight out to the stop. Lift the front and slide the drawer out the rest of the way.
2. Replace the drawer by sliding the drawer in fully past the stop.

**Crisper Cover**

***To remove and replace the crisper cover:***

1. Remove the crisper(s).
2. Pull the glass straight out.
3. Replace the glass by pushing it straight in.



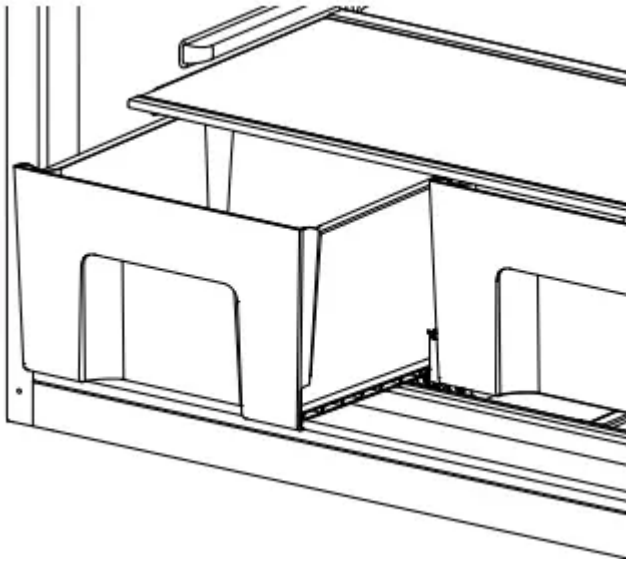

### **Crisper Humidity Control**

You can control the amount of humidity in the moisture-sealed crisper. Adjust the control to LOW or HIGH.

LOW (open) lets moist air out of the crisper for best storage of fruits and vegetables with skins.

- Fruit: Wash, let dry and store in refrigerator in plastic bag or crisper. Do not wash or hull berries until they are ready to use. Sort and keep berries in original container in crisper, or store in a loosely closed paper bag on a refrigerator shelf.
- Vegetables with skins: Place in plastic bag or plastic container and store in crisper

HIGH (closed) keeps moist air in the crisper for best storage of fresh, leafy vegetables.

- Leafy vegetables: Wash in cold water, drain and trim or tear off bruised and discolored areas. Place in plastic bag or plastic container and store in crisper.

## **FREEZER FEATURES**

### **Freezer Shelf**

#### **Full-width Shelf (on some models)**

#### ***To remove and replace the freezer shelf:***

1. Remove items from the shelf.
2. Lift back of shelf over stop and slide shelf straight out.
3. Replace the shelf by sliding the back of the shelf into the tracks on walls of cabinet.
4. Be sure to slide the shelf in all the way.

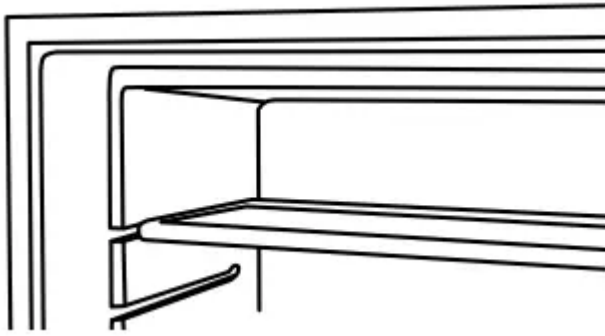

### **Half-width Shelf (on some models)**

IMPORTANT: The half-width shelf can only be installed in the lefthand side of the freezer compartment.

#### ***To remove and replace the freezer shelf:***

1. Remove items from shelf.
2. Remove the shelf screw. Lift back of shelf over stop and slide it out.
3. Replace the shelf by sliding the back of the shelf into the tracks on walls of cabinet. Fasten with the shelf screw.

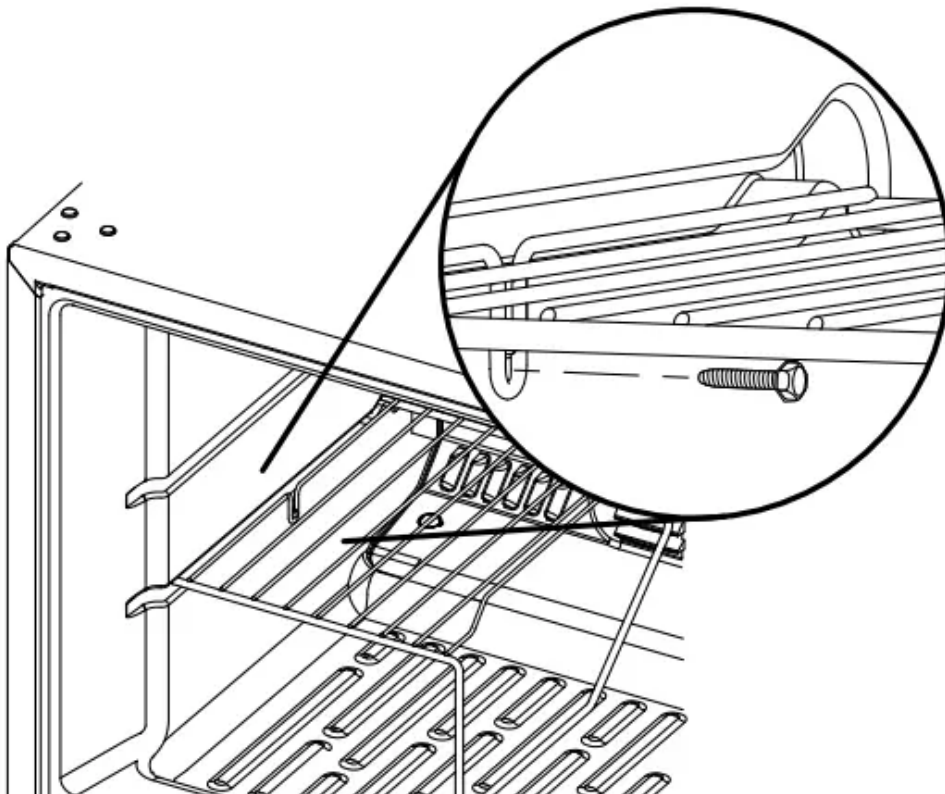

### **Frozen Food Storage Guide**

Storage times will vary according to the quality and type of food, the type of packaging or wrap used (should be airtight and moisture-proof), and the storage temperature. Seal the

package or container securely to avoid taste and odor transfer throughout the product. Ice crystals inside a sealed package are normal. This simply means that moisture in the food and air inside the package have condensed, creating ice crystals.

Put no more unfrozen food into the freezer than will freeze within 24 hours (no more than 2 to 3 lbs of food per cubic foot [907 to 1,350 g per L] of freezer space). Leave enough space in the freezer for air to circulate around packages. The freezer door must close tightly.

NOTE: For more information on preparing food for freezing, check a freezer guide or reliable cookbook.

## DOOR FEATURES

Your model may have some or all of these features.

### Door Rails

The door rails may be removed for easier cleaning.

#### Snap-on Door Rails

To remove and replace the rails:

1. Depending on your model, remove the rails by pushing in slightly on the front of the bracket while pulling out on the inside tab. Repeat these steps for the other end.
2. Replace the rails by aligning the ends of the brackets with the buttons on the sides of the door liner. Firmly snap bracket and assembly onto the tabs above the shelf as shown.

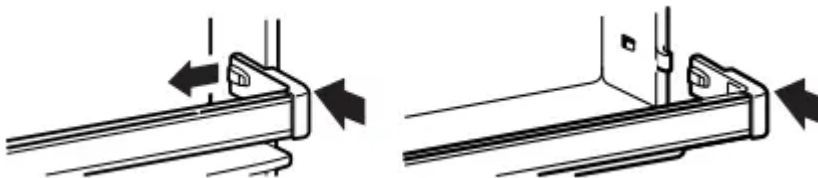

### Utility Compartment

The utility compartment may be removed for easier cleaning.

**To remove and replace the utility compartment:**

1. Remove the utility compartment by squeezing against one side while raising the utility compartment up and pulling it straight out.
2. Replace the utility compartment by positioning one side in the lock and sliding in the opposite side until it stops.

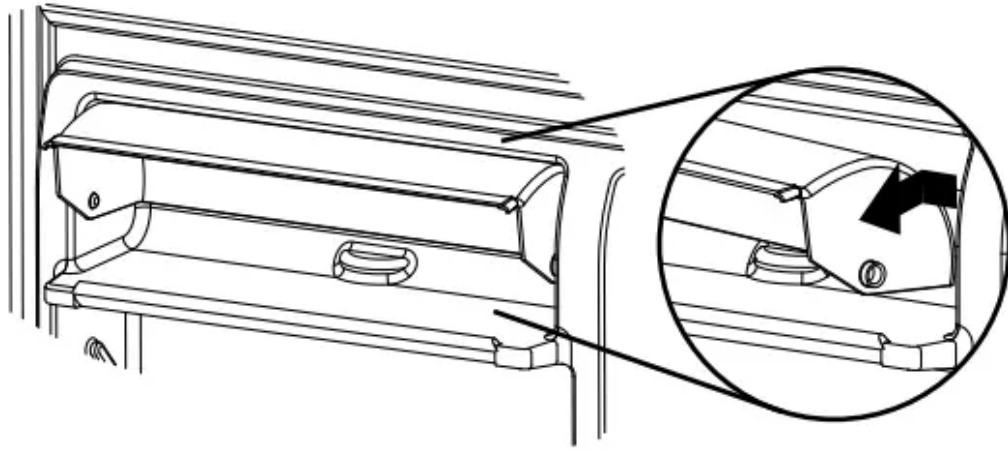

## REFRIGERATOR CARE

### Cleaning

Both the refrigerator and freezer sections defrost automatically. However, clean both sections about once a month to avoid buildup of odors. Wipe up spills immediately.

#### IMPORTANT:

- Because air circulates between both sections, any odors formed in one section will transfer to the other. You must thoroughly clean both sections to eliminate odors. To avoid odor transfer and drying out of food, wrap or cover foods tightly.
- For stainless steel models, stainless steel is corrosionresistant and not corrosion-proof. To help avoid corrosion of your stainless steel, keep your surfaces clean by using the following cleaning instructions.

#### To Clean Your Refrigerator:

**NOTE:** Do not use abrasive or harsh cleaners such as window sprays, scouring cleansers, flammable fluids, muriatic acid, cleaning waxes, concentrated detergents, bleaches or cleansers containing petroleum products on exterior surfaces (doors and cabinet), plastic parts, interior and door liners or gaskets. Do not use paper towels, scouring pads, or other harsh cleaning tools.

1. Unplug refrigerator or disconnect power.
2. Hand wash, rinse, and dry removable parts and interior surfaces thoroughly. Use a clean sponge or soft cloth and a mild detergent in warm water.
3. Clean the exterior surfaces.

**Painted metal:** Wash painted metal exteriors with a clean, soft cloth or sponge and a mild detergent in warm water. Rinse surfaces with clean, warm water and dry immediately to avoid water spots.

**Stainless steel:** Wash stainless steel surfaces with a clean, soft cloth or sponge and a mild detergent in warm water. Rinse surfaces with clean, warm water and dry immediately to avoid water spots.

NOTE: When cleaning stainless steel, always wipe in the direction of the grain to avoid cross-grain scratching.

4. There is no need for routine condenser cleaning in normal home operating environments. If the environment is particularly greasy or dusty, or there is significant pet traffic in the home, the condenser should be cleaned every 2 to 3 months to ensure maximum efficiency.

If you need to clean the condenser:

- Remove the base grille.
- Use a vacuum cleaner with a soft brush to clean the grille, the open areas behind the grille and the front surface area of the condenser.
- Replace the base grille when finished.

5. Plug in refrigerator or reconnect power.

## Changing the Light Bulb

The light bulb is located behind the Temperature control.

IMPORTANT: Depending on your model, the light bulb in your new refrigerator may use LED technology. If your model uses LED lighting and the light does not illuminate when the refrigerator door is opened, call for assistance or service. See Warranty for phone numbers

1. Unplug refrigerator or disconnect power.
2. Remove the light shield by squeezing in on the sides and pulling it straight down.
3. Remove the light bulb, and then replace it with an appliance bulb of the same size, shape and wattage.

### LED Technology models only:

- To replace the LED bulb with an LED bulb, order part number W10565137 (3.6 watts).

NOTE: Some LED replacement bulbs are not recommended for wet/damp environments. The refrigerator and freezer compartments are considered to be wet/damp environments. If using a brand of LED bulb other than the recommended LED bulb, before installation, read and follow all instructions on the LED packaging.

- To replace an LED bulb with an incandescent bulb, use only incandescent bulbs for household appliances with a maximum of 60 watts.

4. Replace the light shield.

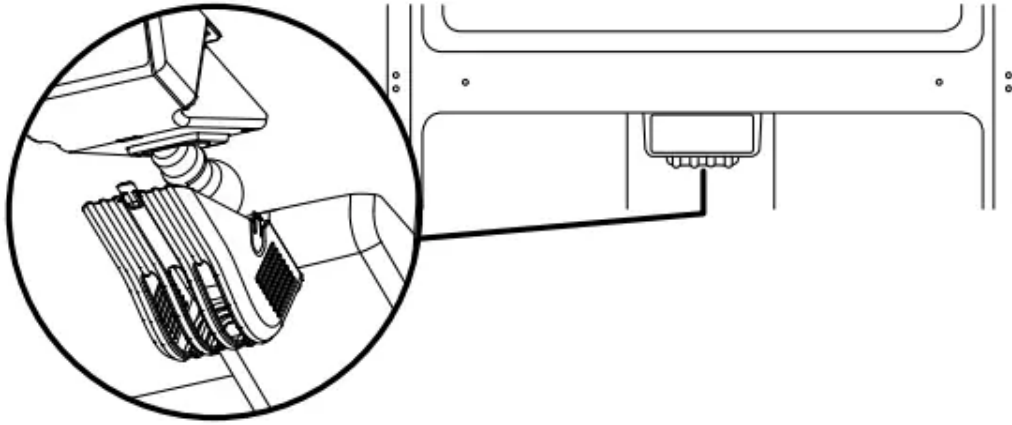

5. Plug in refrigerator or reconnect power.

## Vacation and Moving Care

### Vacations

#### *If You Choose to Leave the Refrigerator On While You're Away:*

1. Use up any perishables and freeze other items.
2. If your refrigerator has an automatic ice maker, and is connected to the household water supply, turn off the water supply to the refrigerator. Property damage can occur if the water supply is not turned off.
3. If you have an automatic ice maker, turn off the ice maker.

NOTE: Raise the wire shutoff arm to OFF (up) position.

4. Empty the ice bin.

#### *If You Choose to Turn Off the Refrigerator Before You Leave:*

1. Remove all food from the refrigerator.
2. If your refrigerator has an automatic ice maker:
  - Turn off the water supply to the ice maker at least one day ahead of time.
  - When the last load of ice drops, raise the wire shutoff arm to the OFF (up) position.
3. Turn off the Temperature control(s). See "Using the Control(s)."
4. Clean refrigerator, wipe it, and dry well.
5. Tape rubber or wood blocks to the tops of both doors to prop them open far enough for air to get in. This stops odor and mold from building up.

### Moving

When you are moving your refrigerator to a new home, follow these steps to prepare it for the move.

1. If your refrigerator has an automatic ice maker:
  - Turn off the water supply to the ice maker at least one day ahead of time.
  - Disconnect the water line from the back of the refrigerator.
  - When the last load of ice drops, raise the wire shutoff arm to the OFF (up) position.
2. Remove all food from the refrigerator and pack all frozen food in dry ice.
3. Empty the ice bin.
4. Turn off the Temperature control(s). See “Using the Control(s).”
5. Unplug refrigerator.
6. Clean, wipe, and dry thoroughly.
7. Take out all removable parts, wrap them well, and tape them together so they don't shift and rattle during the move.
8. Depending on the model, raise the front of the refrigerator so it rolls more easily OR raise the leveling screws so they don't scrape the floor. See “Adjust the Door(s)” or “Door Closing and Door Alignment.”
9. Tape the doors closed and tape the power cord to the back of the refrigerator.

When you get to your new home, put everything back and refer to the “Installation Instructions” section for preparation instructions. Also, if your refrigerator has an automatic ice maker, remember to reconnect the water supply to the refrigerator.

# PROBLEM SOLVER



If you experience	Possible Causes and/or Recommended Solutions
<p>The refrigerator will not operate</p>	<ul style="list-style-type: none"> <li>■ Not connected to an electrical supply - Plug the power cord into a grounded 3 prong outlet. Do not use an extension cord.</li> <li>■ No power to the electrical outlet - Plug in a lamp to see if the outlet is working.</li> <li>■ Household fuse blown or circuit breaker tripped - Replace the fuse or reset the circuit breaker. If the problem continues, contact an electrician.</li> <li>■ Control is not turned on - Turn the refrigerator control on.</li> <li>■ New installation - Allow 24 hours following installation for the refrigerator to cool completely.</li> </ul> <p>NOTE: Adjusting the temperature control(s) to coldest setting will not cool the refrigerator more quickly.</p>
<p>The motor seems to run too much</p>	<p>Your new refrigerator may run longer than your old one. Energy efficient refrigerators run longer at lower, more energy efficient speeds. Your refrigerator may run even longer if the room is warm, a large food load is added, the door is opened often, or if the door has been left open.</p>
<p>The refrigerator is noisy</p>	<p>Refrigerator noise has been reduced over the years. Due to this reduction in operating noise, you may notice unfamiliar noises that are normal. Following are some normal sounds with an explanation:</p> <ul style="list-style-type: none"> <li>■ Buzzing - heard when the water valve opens to fill the ice maker</li> <li>■ Clicking/Snapping - valves opening or closing</li> <li>■ Pulsating - fans/compressor adjusting to optimize performance</li> <li>■ Rattling - flow of refrigerant, water line, or from items placed on top of the refrigerator</li> <li>■ Sizzling/Gurgling - water dripping on the heater during defrost cycle</li> <li>■ Popping - contraction/expansion of inside walls, especially during initial cool-down</li> </ul>



	<ul style="list-style-type: none"> <li>■ Water running - may be heard when ice melts during the defrost cycle and water runs into the drain pan</li> <li>■ Creaking/Cracking - occurs as ice is being ejected from the ice maker mold</li> </ul>
The door will not close completely	<ul style="list-style-type: none"> <li>■ The door is blocked open - Move food packages away from door. Push bin or shelf back into the correct position. Make sure the crisper cover is fully pushed in, so that the back rests on the supports.</li> </ul>
The door is difficult to open	<ul style="list-style-type: none"> <li>■ Gaskets are dirty or sticky - Clean gaskets and contact surfaces with mild soap and warm water. Rinse and dry with soft cloth.</li> </ul>
Temperature is too warm	<ul style="list-style-type: none"> <li>■ New installation - Allow 24 hours following installation for the refrigerator to cool completely.</li> <li>■ Door(s) opened often or not closed completely - Allows warm air to enter refrigerator. Minimize door openings and keep doors fully closed.</li> <li>■ A large amount of warm food has been recently added - Allow several hours for refrigerator to return to normal temperature.</li> <li>■ Check that the Temperature control(s) are set correctly for the surrounding conditions - Adjust the controls to one setting colder. Check temperature in 24 hours. See "Using the Control(s)."</li> </ul>
There is interior moisture buildup  NOTE: Some moisture buildup is normal.	<ul style="list-style-type: none"> <li>■ Humid room - Contributes to moisture buildup in the refrigerator.</li> <li>■ Door(s) opened often or not closed completely - Allows humid air to enter the refrigerator. Minimize door openings and keep door fully closed.</li> </ul>
The ice maker is not producing ice or not enough ice (on some models)	<ul style="list-style-type: none"> <li>■ The ice maker is not connected to a water supply - Connect refrigerator to water supply and turn water shutoff valve fully open.</li> <li>■ A kink in the line can reduce water flow - Straighten the water source line.</li> </ul>



	<ul style="list-style-type: none"> <li>■ Ice maker is not turned on - Make sure the ice maker wire shutoff arm or switch (depending on model) is in the ON position.</li> <li>■ New installation - Wait 24 hours after ice maker installation for ice production to begin. Wait 3 days for full ice production.</li> <li>■ Large amount of ice recently removed - Allow sufficient time for ice maker to produce more ice.</li> <li>■ Ice cube jammed in the ice maker ejector arm - Remove ice from the ejector arm with a plastic utensil.</li> <li>■ A reverse osmosis water filtration system connected to your cold water supply can decrease water pressure - See “Water Supply Requirements.”</li> </ul>
<p>The ice cubes are hollow or small (on some models)</p> <p>NOTE: This is an indication of low water pressure.</p>	<ul style="list-style-type: none"> <li>■ The water valve is not completely open - Turn the water shutoff valve fully open.</li> <li>■ A kink in the line can reduce water flow - Straighten the water source line.</li> <li>■ A reverse osmosis water filtration system connected to your cold water supply can decrease water pressure - See “Water Supply Requirements.”</li> <li>■ If questions regarding water pressure remain, call a licensed, qualified plumber.</li> </ul>
<p>Off-taste, odor or gray color in the ice (on some models)</p>	<ul style="list-style-type: none"> <li>■ New plumbing connections can cause discolored or off-flavored ice - Discard the ice and wash the ice storage bin. Allow 24 hours for the ice maker to make new ice, and discard the first 3 batches of ice produced.</li> <li>■ Ice stored too long can develop an off-taste - Discard ice. Wash ice bin. Allow 24 hours for ice maker to make new ice.</li> <li>■ Food odor transferring to ice - Use airtight, moisture proof packaging to store food.</li> <li>■ There are minerals (such as sulfur) in the water - A water filter may need to be installed to remove the minerals.</li> </ul>



**Warning**

This content is compiled from multiple sources and is provided for reference purposes only. It may not be complete or fully applicable to all situations. If you are unable to resolve your issue, please contact the product manufacturer or an authorized service provider for official support.

---

Document generated by [ManualsFile](#)