

Use & Care Guide for Coffee Maker

Parts and Features

BEFORE FIRST USE: Wash all removable parts in hot, soapy water. Rinse and dry. Brew one cycle with water and discard water.

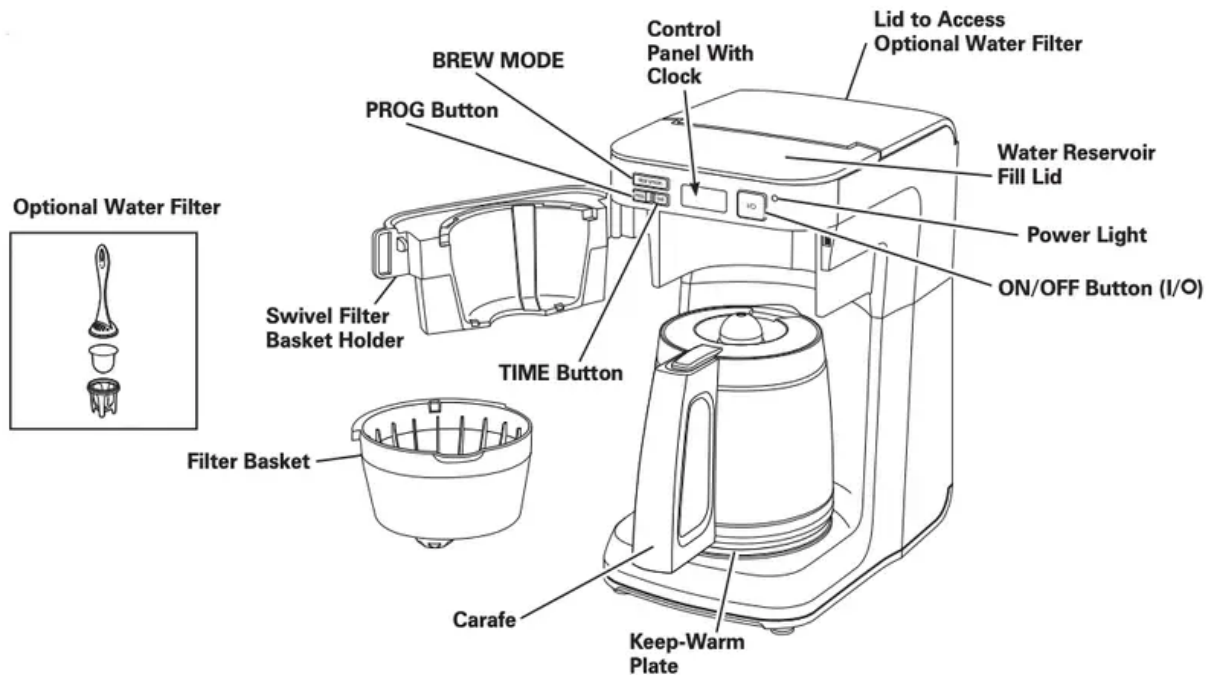

How to Make Coffee

WARNING Burn Hazard. To avoid hot coffee overflowing from the filter basket:

- When using decaffeinated coffee, do not exceed the coffee manufacturer's recommended serving amount.
- Ensure swivel filter basket is completely closed.

If filter basket overflow occurs, unplug coffee maker and allow coffee in filter basket to cool before removing filter basket.

WARNING Shock Hazard. Do not immerse cord, plug, or coffee maker in any liquid.

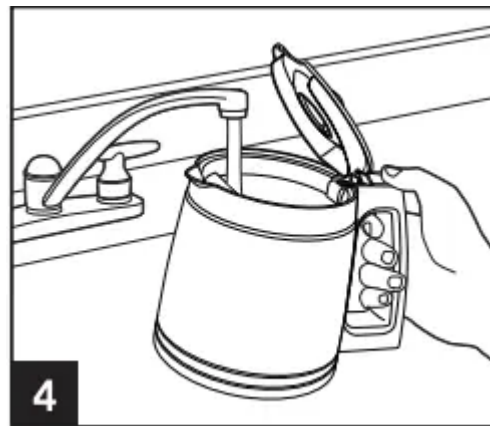
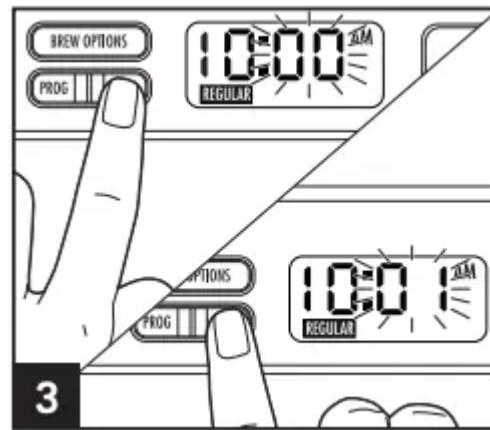
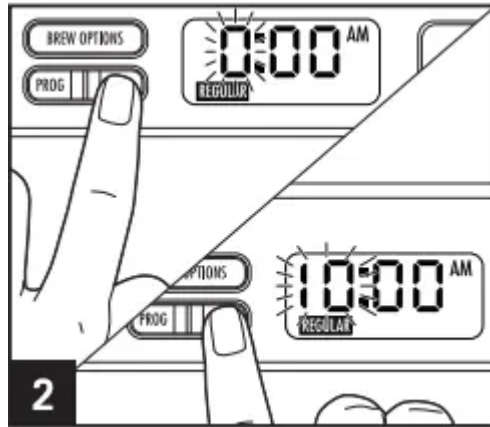
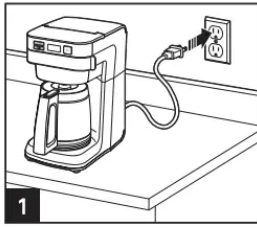

Press and release TIME button. Hour will flash in display. Press and pulse TIME button to increase to set current hour in AM or PM. Wait 3 seconds; minutes will flash. Press and pulse TIME button to increase to set current minutes. Set time will display constant.



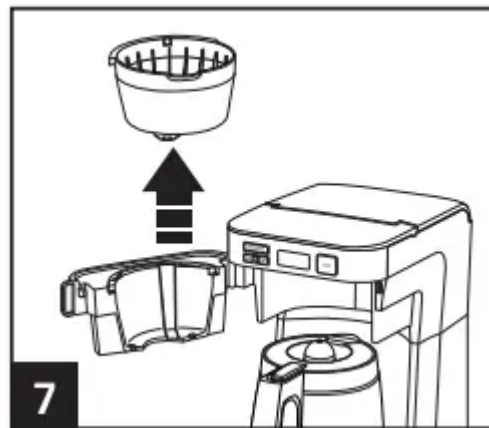
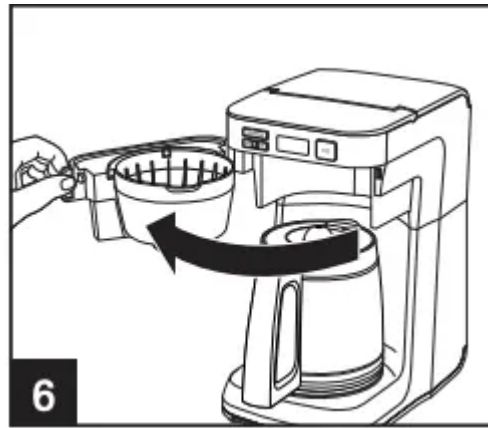

Lift water reservoir fill lid to add water.

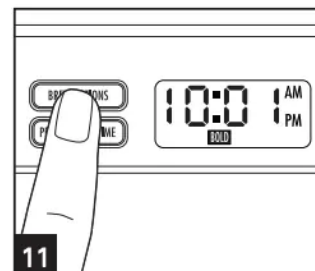
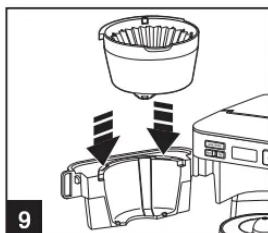

For each cup of coffee being made, place one level tablespoon of ground coffee into filter. A permanent filter may also be used with the filter basket.

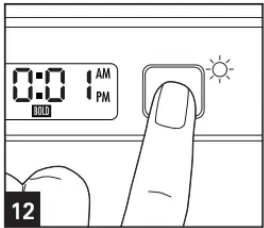
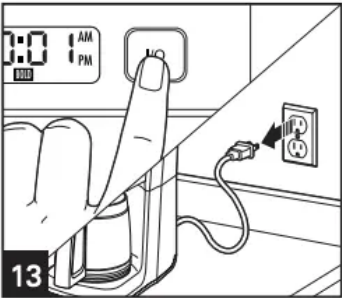

<p>Place brew basket tabs in slots in filter basket holder.</p>	<p>Close swivel filter basket holder before brewing, and do not open until brewing cycle is complete and unit is cool.</p>	<p>Select your brew option. (See “How to Use the Brew Options.”)</p>
 <p>12</p> <p>Press I/ ON/OFF button once to turn on the coffee maker. Power light will illuminate.</p>	 <p>13</p> <p>When finished, press I/ ON/OFF button once and unplug.</p> <p>NOTE: If the coffee maker is not turned off manually, it will automatically shut off in 2 hours and the power light will turn off.</p>	 <p>14</p> <p>Wash in warm, soapy water. Rinse and dry.</p>
 <p>DISHWASHER-SAFE (top rack)</p> <p>Dishwasher-safe wash and dry in TOP RACK only.</p>		

To Program Automatic Brew

NOTE: White LED will illuminate to indicate PROGRAM is activated. White LED light will turn off when the unit begins to brew at the preprogrammed time.

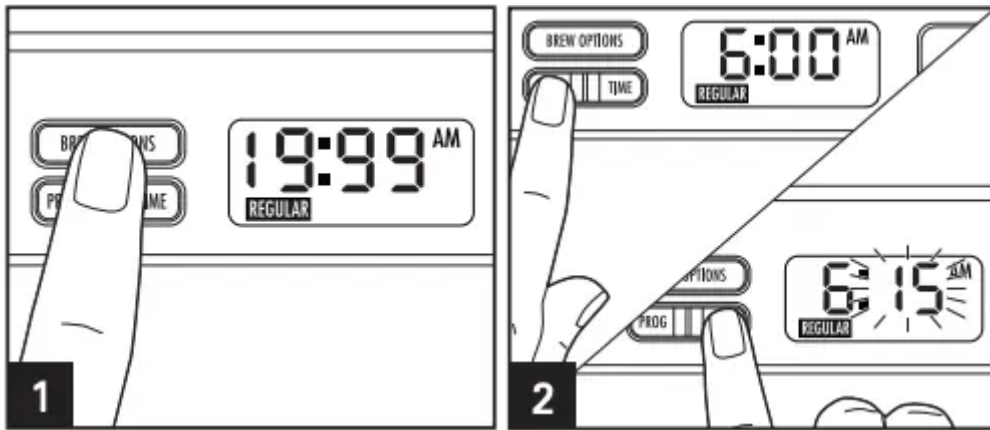

Choose a brew option. Then, hold PROG button. Next, press and pulse TIME button to set desired brewing hour in AM or PM. Wait 3 seconds; minutes will flash. Then press and pulse TIME button to increase to set minutes. Set time will display constant. Release PROG and current time is displayed.

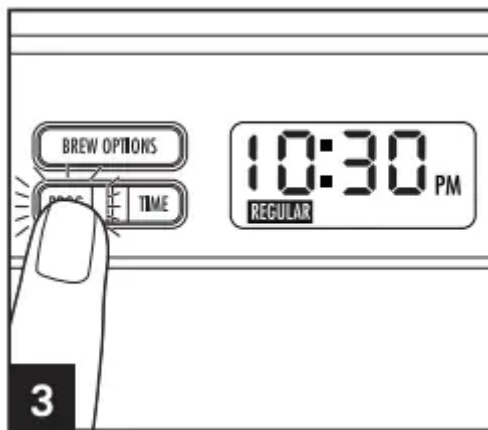

Press and release PROG again to activate automatic brew. PROG light will illuminate.

Tips for Best-Tasting Coffee

- All coffees are made from either arabica beans or robusta beans, or some combination of both. Arabica beans are slightly more expensive, but tend to produce better-tasting coffee.
- Ground coffee will become stale much faster than whole beans. If buying preground coffee, chose a package with the latest expiration date or a smaller quantity.
- If grinding whole beans, set your coffee grinder on a fine/ medium grind. This will yield the best-tasting grounds. Try to use freshly ground coffee within about a week of grinding.
- Using a water filter, filtered water, or bottled water will yield better-tasting coffee than tap water.
- Use approximately 1 tablespoon of grounds for each cup of coffee being made. To avoid overflow, use about 1/3 less grounds when brewing decaf or flavored coffees.

- Make sure your coffee maker is clean. See “Care and Cleaning” section.

How to Use the Brew Options and Clean Notification

BREW OPTIONS

Your coffee maker will default to the “Regular” strength coffee setting when brewing.

NOTE: Using the brew strength options will increase the length of brewing time slightly.

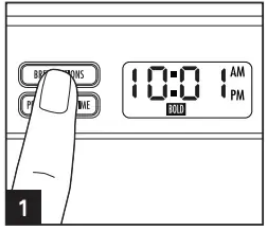
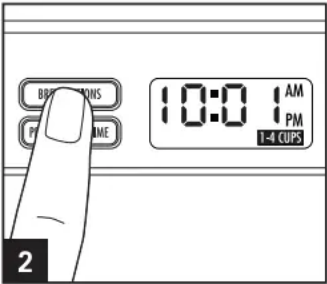
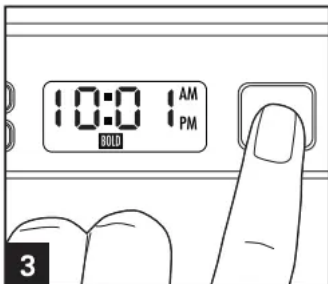
 <p>1</p> <p>For stronger coffee, press the BREW OPTIONS button until “BOLD” is illuminated.</p>	 <p>2</p> <p>For small amounts, use the 1–4 cup setting by pressing the BREW OPTIONS button until “1–4 CUPS” is illuminated.</p>	 <p>3</p> <p>Then, press the I/ ON/OFF button or set the Automatic Brew to start the coffee maker after your brew option has been selected.</p>
--	--	--

CLEAN NOTIFICATION

If unit is always plugged in, after 30 cycles CLEAN will scroll across the display. Follow the directions for “Care and Cleaning.”

NOTES:

- Performing the cleaning procedure will clear the display.
- The brew cycle counter resets every time the coffee maker is unplugged.

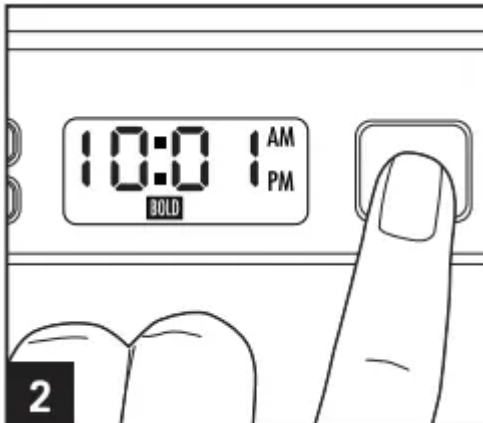
 <p>1</p>	 <p>2</p>
---	--

If you do not want to perform the cleaning procedure, press the I/ ON/OFF button two times to clear the display.

Care and Cleaning

WARNING Shock Hazard. Do not immerse cord, plug, or coffee maker in any liquid.

All coffee makers should be cleaned at least once a month (once a week for areas with hard water).

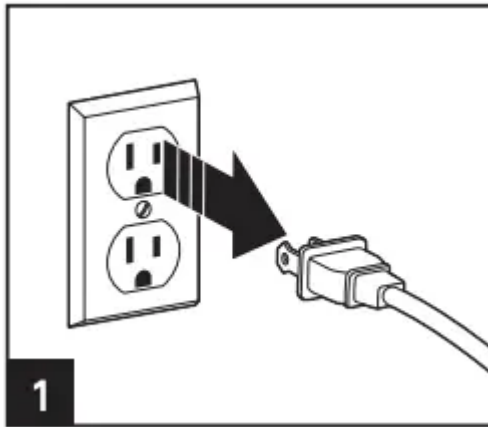

Unplug coffee maker (this resets brew counter for cleaning mode notification). Wipe coffee maker with a damp cloth or sponge. Dry. Remove water filter and water filter base (see “How to Replace the Water Filter”). Pour a minimum of 1 pint (2 cups/473 ml) white vinegar into water reservoir.

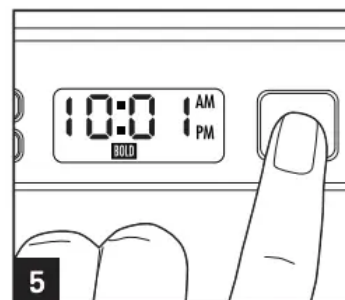
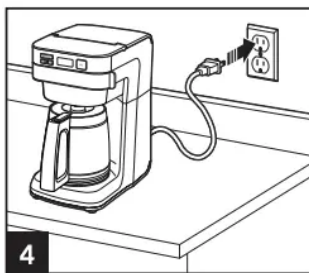

Press the I/ ON/OFF button once. After 30 seconds, turn OFF. Wait 30 minutes to allow vinegar to clean. Then turn ON again. When brew cycle is finished, wait for unit to cool.

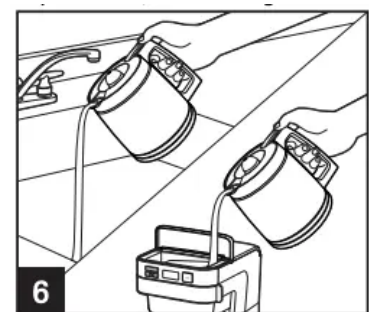

Empty carafe and rinse. Run 2–3 more brew cycles with CLEAN WATER only. Allow to cool between cycles.



How to Replace the Water Filter (optional accessory)

For better-tasting coffee, use a water filter. Filter replacement is recommended every 60 cycles

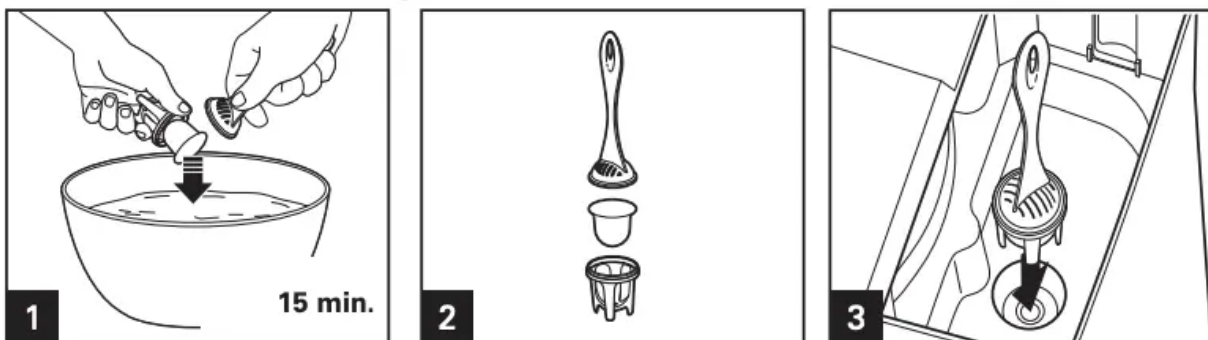

Carafe Safety Precautions

- Do not use a cracked carafe or a carafe having a loose or weakened handle.
- This carafe is designed to be used only on the keep-hot plate of your coffee maker. Do not use on a gas or electric rangetop, or in a microwave or conventional oven.
- To avoid breakage, handle carafe with care. Avoid impact. Glass will break as a result of impact. Use care when filling with water to avoid hitting faucet.
- Do not place hot carafe on cool or wet surface. Allow to cool before washing or adding liquids.
- Do not set empty carafe on a hot heating surface.
- Do not clean with steel wool pads, abrasive cleanser, or any other materials that may scratch.



This symbol alerts you to the potential danger for personal injury if you fail to read and follow these safety precautions



This symbol reminds you that glass is fragile and can break which could result in personal injury.

- Do not place hands inside carafe. When handling, be careful if wearing any hand jewelry, especially diamond rings. Jewelry can scratch the glass, which increases possibility of breakage.
- Do not bump, scratch, or boil dry.
- Discard carafe if it is cracked, scratched, or heated while empty for an extended period of time.
- To avoid accidents, do not pour in the direction of people.
- If stirring in the carafe, use only wooden, plastic, or rubber utensils. Do not use metal utensils.
- Follow the above safety precautions carefully to avoid serious burn injuries which may result if breakage occurs while carafe holds heated liquids.

Troubleshooting

PROBLEM	PROBABLE CAUSE/SOLUTION
<p>Filter basket overflows or coffee brews slowly.</p>	<ul style="list-style-type: none"> • The “BOLD” or 1–4 cup brew option is recommended for brewing decaffeinated coffee. • Excessive amounts of coffee. • Coffee ground too finely (not automatic drip grind). • Carafe not securely placed on keep-warm plate or swivel filter basket holder not closed completely. • Carafe removed during brewing for more than 20 seconds and not placed securely back on keepwarm plate. • Coffee maker needs cleaning. • Coffee grounds between paper filter and filter basket. • Paper filter not open and in proper position. • Press the seamed edges of paper filter before inserting into basket. • Rinse filter basket before inserting paper filter so the edges will remain pressed against the sides of the basket. • Poor-quality paper filter.
<p>Coffee not brewing/unit will not turn on.</p>	<ul style="list-style-type: none"> • Water reservoir is empty. • Unit is unplugged. • Power outage. • Power surge. Unplug; then plug the unit back in. • Clock requires reset after power outage.

Warning

This content is compiled from multiple sources and is provided for reference purposes only. It may not be complete or fully applicable to all situations. If you are unable to resolve your issue, please contact the product manufacturer or an authorized service provider for official support.

